

MHP13/MHP17

HYDRAULIC MOTORS



T E C H N I C A L C A T A L O G



MHP MOTORS

The new MHP hydraulic motors represent the keystone of the High Performance system proposed by Poclair Hydraulics.

Thanks to their innovative design, the MHP motors will offer superior performances (higher speed and power, working pressure of 500 bar) compared to conventional cam-lobe motors. These characteristics make these components suitable for any applications requiring highly performing hydraulic drives, such as agricultural machines, drilling rigs or industrial applications.

But besides their performance, the MHP motors will also allow improvement of the global efficiency of the transmission resulting in lower fuel consumption for the machine, while ensuring higher robustness and reliability, which are required for the most demanding applications.

From
900 cc
to **3 500 cc**

Up to
520 rpm

Up to
24 kN.m

Up to
280 kW

Up to
500 bar

Up to
4 speeds

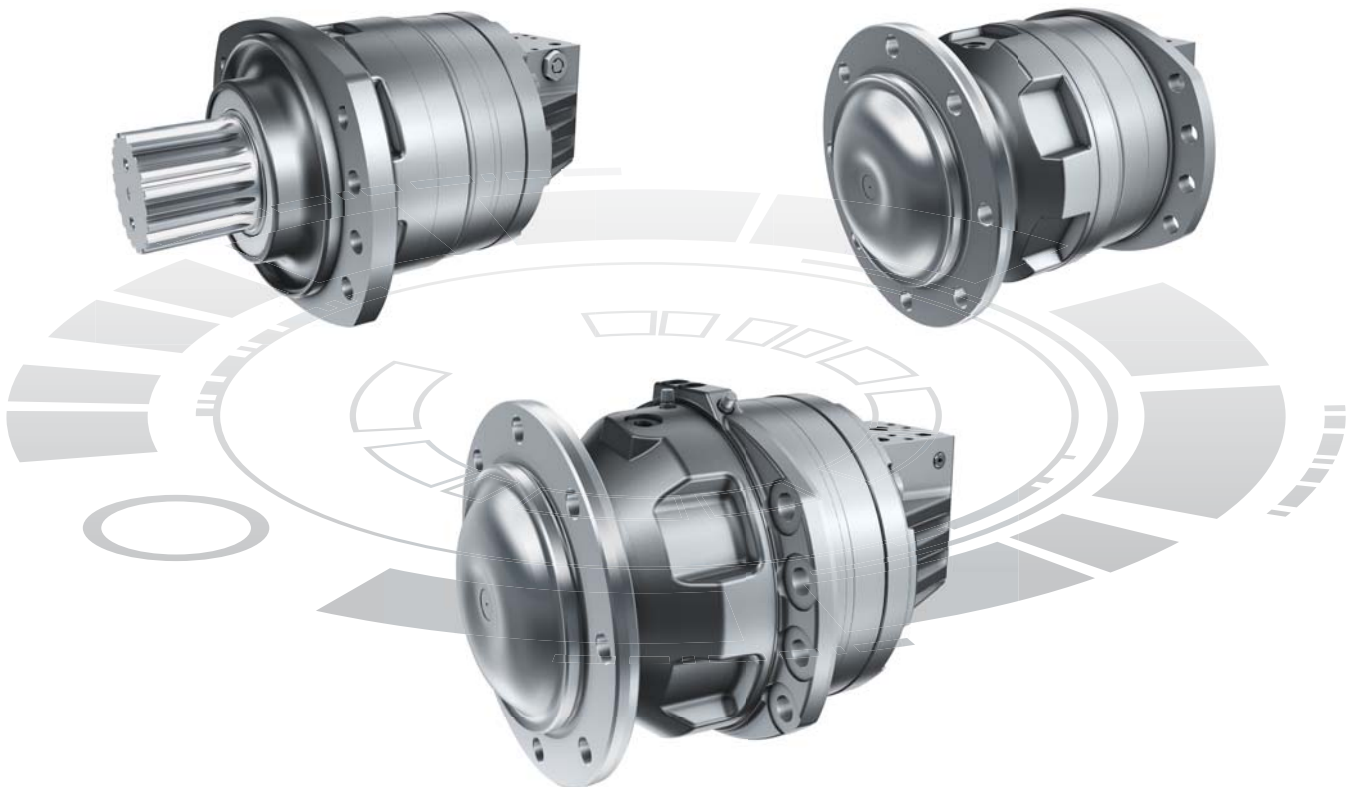

HIGH PERFORMANCE



CONTENT



MODEL CODE	8	
MODULARITY	10	▶
WHEEL MOTOR	13	▶
Dimensions for standard (1610) motor	13	
Support types	13	
Load curves	14	
WHEEL MOTOR WITH SERVICE BRAKE	15	▶
Dimensions for standard (W710) motor	15	
Dimensions for standard (V710) motor	16	
Support types	17	
Load curves	18	
WHEEL MOTOR WITH PARKING BRAKE	19	▶
Dimensions for standard (R710) motor	19	
Dimensions for standard (S710) motor	20	
Support types	21	
Load curves	22	
SHAFT MOTOR	23	▶
Dimensions for standard (2A10 / 2A50) motor	23	
Support types	24	
Splined coupling	24	
Load curves	25	
SHAFT MOTOR WITH PARKING BRAKE	26	▶
Dimensions for standard (SA10 / SA50) motor	26	
Support types	27	
Splined coupling	27	
Load curves	28	
BRAKES	29	▶
S17™ Service brake	29	
P17™ Parking brake	30	
Boosted brake™	31	
INSTALLATION	33	▶
Customer's chassis and wheel rim mountings	33	
Hydraulic connections	34	
Valving cover orientation	35	
Motor orientation and balancing during handling	35	
Speed shifting logic	36	
OPTIONS	37	▶

Model code and Modularity

Wheel motor

Wheel motor +S17™ brake

Wheel motor +P17™ brake

Shaft motor

Shaft motor +P17™ brake

Brakes

Installation

Options



MHP13

		bar [PSI]	500 [7 252]			500 [7 252]			500 [7 252]		
			1	2	3	1	2	3	1	2	3
1C Distribution	Max. pressure	bar [PSI]	500 [7 252]			500 [7 252]			500 [7 252]		
	Displacement	cm ³ /rev [in ³ /rev.]	900 [54.9]			1 035 [63.2]			1 155 [70.5]		
	Max. speed	rpm	520			462			415		
	Max. power	kW [HP]	148 [198]			151 [202]			151 [202]		
	Th. torque at 100 bar [1000 PSI]	Nm [Lb.ft]	1 431 [727]			1 646 [837]			1 836 [933]		
2C Distribution (6/2)	Displacement	cm ³ /rev [in ³ /rev.]	900 [54.9]	300 [18.3]		1 035 [63.2]	345 [21.1]		1 155 [70.5]	385 [23.5]	
	Max. speed	rpm	421	548		373	488		335	440	
	Max. power (preferred direction)	kW [HP]	153 [205]	125 [168]		158 [212]	128 [172]		153 [205]	129 [173]	
	Th. torque at 100 bar [1000 PSI]	Nm [Lb.ft]	1 431 [727]	477 [242]		1 646 [837]	549 [279]		1 836 [933]	612 [311]	
3C Distribution (6/4/2)	Displacement	cm ³ /rev [in ³ /rev.]	900 [54.9]	600 [36.6]	300 [18.3]	1 035 [63.2]	690 [42.1]	345 [21.1]	1 155 [70.5]	770 [46.9]	385 [23.5]
	Max. speed	rpm	420	451	491	373	401	436	335	360	393
	Max. power (preferred direction)	kW [HP]	153 [205]	142 [190]	118 [158]	154 [207]	144 [193]	120 [161]	153 [205]	141 [189]	121 [162]
	Th. torque at 100 bar [1000 PSI]	Nm [Lb.ft]	1 431 [727]	954 [485]	477 [243]	1 646 [837]	1 097 [558]	549 [279]	1 836 [933]	1 224 [622]	612 [311]

1 First displacement **2** Second displacement **3** Third displacement



The maximum motor speed can be impacted by the type of bearing support. For a precise calculation, please consult your Poclain Hydraulics application engineer.



The maximum motor power is obtained at maximum speed. In non-preferred rotation direction of 2/3-displacement, the maximum power is reduced. For a precise calculation, please consult your Poclain Hydraulics application engineer.



CHARACTERISTICS

		C			0 0 0			1 1 1			2 2 2		
Max. pressure		bar [PSI]			500 [7 252]			500 [7 252]			500 [7 252]		
		1	2	3	1	2	3	1	2	3	1	2	3
1C Distribution	Displacement	cm ³ /rev [in ³ /rev.]	1 287 [78.5]			1 413 [86.2]			1 542 [94.1]				
	Max. speed	rpm	376			344			317				
	Max. power	kW [HP]	150 [201]			145 [194]			142 [190]				
	Th. torque at 100 bar [1000 PSI]	Nm [Lb.ft]	2 046 [1 040]			2 247 [1 143]			2 452 [1 247]				
2C Distribution (6/2)	Displacement	cm ³ /rev [in ³ /rev.]	1 287 [78.5]	429 [26.2]		1 413 [86.2]	471 [28.7]		1 542 [94.1]	514 [31.3]			
	Max. speed	rpm	304	400		278	366		256	337			
	Max. power (preferred direction)	kW [HP]	150 [201]	127 [170]		145 [194]	124 [166]		137 [184]	117 [157]			
	Th. torque at 100 bar [1000 PSI]	Nm [Lb.ft]	2 046 [1040]	682 [347]		2 247 [1 143]	749 [381]		2 452 [1 247]	817 [415]			
3C Distribution (6/4/2)	Displacement	cm ³ /rev [in ³ /rev.]	1 287 [78.5]	858 [52.3]	429 [26.2]	1 413 [86.2]	942 [57.5]	471 [28.7]	1 542 [94.1]	1 028 [62.7]	514 [31.4]		
	Max. speed	rpm	304	327	357	278	299	326	256	275	301		
	Max. power (preferred direction)	kW [HP]	150 [201]	138 [185]	123 [165]	146 [196]	134 [180]	118 [158]	137 [184]	130 [174]	114 [153]		
	Th. torque at 100 bar [1000 PSI]	Nm [Lb.ft]	2 046 [1 040]	1 364 [694]	682 [347]	2 247 [1 143]	1 498 [762]	749 [381]	2 452 [1 247]	1 635 [831]	817 [415]		

1 First displacement 2 Second displacement 3 Third displacement



The maximum motor speed can be impacted by the type of bearing support. For a precise calculation, please consult your Poclain Hydraulics application engineer.



The maximum motor power is obtained at maximum speed. In non-preferred rotation direction of 2/3-displacement, the maximum power is reduced. For a precise calculation, please consult your Poclain Hydraulics application engineer.

Overall efficiency

Average values given for guidance for code 0 displacement after 100 hours of operation with HV46 hydraulic fluid at 50°C [122°F].

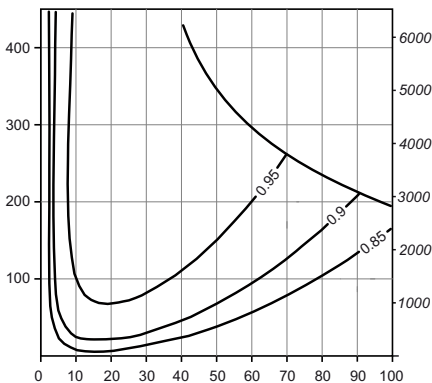
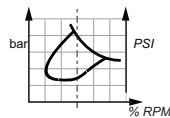

The starting torque is taken to be approximately 85% of the first value for available pressure. For a precise calculation, consult your Poclain Hydraulics application engineer.

- Model code and Modularity
- Wheel motor
- Wheel motor +S17™ brake
- Wheel motor +P17™ brake
- Shaft motor
- Shaft motor +P17™ brake
- Brakes
- Installation
- Options



MHP17

		C			7 7 7			8 8 8			9 9 9			0 0 0		
Max. pressure		bar [PSI]														
		500 [7 252]														
		1	2	3	1	2	3	1	2	3	1	2	3	1	2	3
1C Distribution	Displacement	cm ³ /rev [in ³ /rev.]	1 200 [73.2]			1 383 [84.4]			1 545 [94.3]			1 722 [105]				
	Max. speed	rpm	379			335			300			272				
	Max. power	kW [HP]	216 [290]			230 [308]			240 [322]			246 [330]				
	Th. torque at 100 bar [1000 PSI]	Nm [Lb.ft]	1 908 [970]			2 199 [1 118]			2 457 [1 249]			2 738 [1 392]				
2C Distribution (6/2)	Displacement	cm ³ /rev [in ³ /rev.]	1 200 [73.2]	400 [24.4]		1 383 [84.4]	461 [28.1]		1 545 [94.3]	515 [31.4]		1 722 [105]	574 [35]			
	Max. speed	rpm	312	398		276	353		247	317		224	287			
	Max. power (preferred direction)	kW [HP]	212 [284]	128 [172]		224 [300]	130 [174]		232 [311]	131 [176]		236 [316]	132 [177]			
	Th. torque at 100 bar [1000 PSI]	Nm [Lb.ft]	1 908 [970]	636 [323]		2 199 [1 118]	733 [373]		2 457 [1 249]	819 [416]		2 738 [1 392]	913 [464]			
3C Distribution (6/4/2)	Displacement	cm ³ /rev [in ³ /rev.]	1 200 [73.2]	800 [48.8]	400 [24.4]	1 383 [84.4]	922 [56.3]	461 [28.1]	1 545 [94.3]	1 030 [62.9]	515 [31.4]	1 722 [105]	1 148 [70.1]	574 [35]		
	Max. speed	rpm	312	333	360	276	295	319	247	264	286	224	239	259		
	Max. power (preferred direction)	kW [HP]	212 [284]	206 [276]	116 [156]	224 [300]	217 [291]	117 [157]	231 [310]	219 [294]	119 [160]	236 [316]	220 [295]	119 [160]		
	Th. torque at 100 bar [1000 PSI]	Nm [Lb.ft]	1 908 [970]	1 272 [647]	636 [323]	2 199 [1 118]	1 466 [746]	733 [373]	2 457 [1 249]	1 638 [833]	819 [416]	2 738 [1 392]	1 825 [928]	913 [464]		

1 First displacement **2** Second displacement **3** Third displacement



The maximum motor speed can be impacted by the type of bearing support. For a precise calculation, please consult your Poclain Hydraulics application engineer.



The maximum motor power is obtained at maximum speed. In non-preferred rotation direction of 2/3-displacement, the maximum power is reduced. For a precise calculation, please consult your Poclain Hydraulics application engineer.



CHARACTERISTICS

		C			1 1 1			2 2 2			3 3 3		
	Max. pressure	bar [PSI]											
		500 [7 252]			500 [7 252]			500 [7 252]					
		①	②	③	①	②	③	①	②	③			
1C Distribution	Displacement	cm ³ /rev [in ³ /rev.]	1 890 [115.3]			2 058 [125.6]			2 238 [136.6]				
	Max. speed	rpm	248			228			211				
	Max. power	kW [HP]	249 [334]			249 [334]			241 [323]				
	Th. torque at 100 bar [1000 PSI]	Nm [Lb.ft]	3 005 [1 528]			3 272 [1 664]			3 558 [1 809]				
2C Distribution (6/2)	Displacement	cm ³ /rev [in ³ /rev.]	1 890 [115.3]	630 [38.4]		2 058 [125.6]	686 [41.9]		2 238 [136.6]	746 [45.5]			
	Max. speed	rpm	204	263		188	242		174	224			
	Max. power (preferred direction)	kW [HP]	241 [323]	133 [178]		235 [315]	133 [178]		227 [304]	134 [180]			
	Th. torque at 100 bar [1000 PSI]	Nm [Lb.ft]	3 005 [1 809]	1 002 [510]		3 272 [1 664]	1 091 [554]		3 558 [1 809]	1 186 [603]			
3C Distribution (6/4/2)	Displacement	cm ³ /rev [in ³ /rev.]	1 890 [115.3]	1 260 [76.9]	630 [38.4]	2 058 [125.6]	1 372 [83.7]	686 [41.9]	2 238 [136.6]	1 492 [91.0]	746 [45.5]		
	Max. speed	rpm	204	219	237	188	201	218	174	187	202		
	Max. power (preferred direction)	kW [HP]	250 [335]	221 [296]	120 [161]	235 [315]	220 [295]	120 [161]	238 [319]	213 [286]	121 [162]		
	Th. torque at 100 bar [1000 PSI]	Nm [Lb.ft]	3 005 [1 528]	2 003 [1 019]	1 002 [510]	3 272 [1 664]	2 181 [1 109]	1 091 [554]	3 558 [1 809]	2 372 [1 206]	1 186 [603]		

① First displacement ② Second displacement ③ Third displacement



The maximum motor speed can be impacted by the type of bearing support. For a precise calculation, please consult your Poclain Hydraulics application engineer.



The maximum motor power is obtained at maximum speed. In non-preferred rotation direction of 2/3-displacement, the maximum power is reduced. For a precise calculation, please consult your Poclain Hydraulics application engineer.

Overall efficiency

Average values given for guidance for code 0 displacement after 100 hours of operation with HV46 hydraulic fluid at 50°C [122°F].

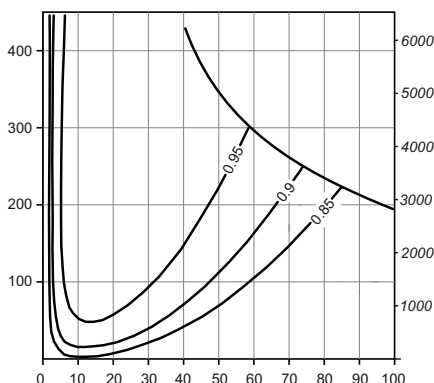
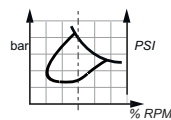

The starting torque is taken to be approximately 85% of the first value for available pressure. For a precise calculation, consult your Poclain Hydraulics application engineer.

Model code and Modularity

Wheel motor

Wheel motor +S17™ brake

Wheel motor +P17™ brake

Shaft motor

Shaft motor +P17™ brake

Brakes

Installation

Options



MODEL

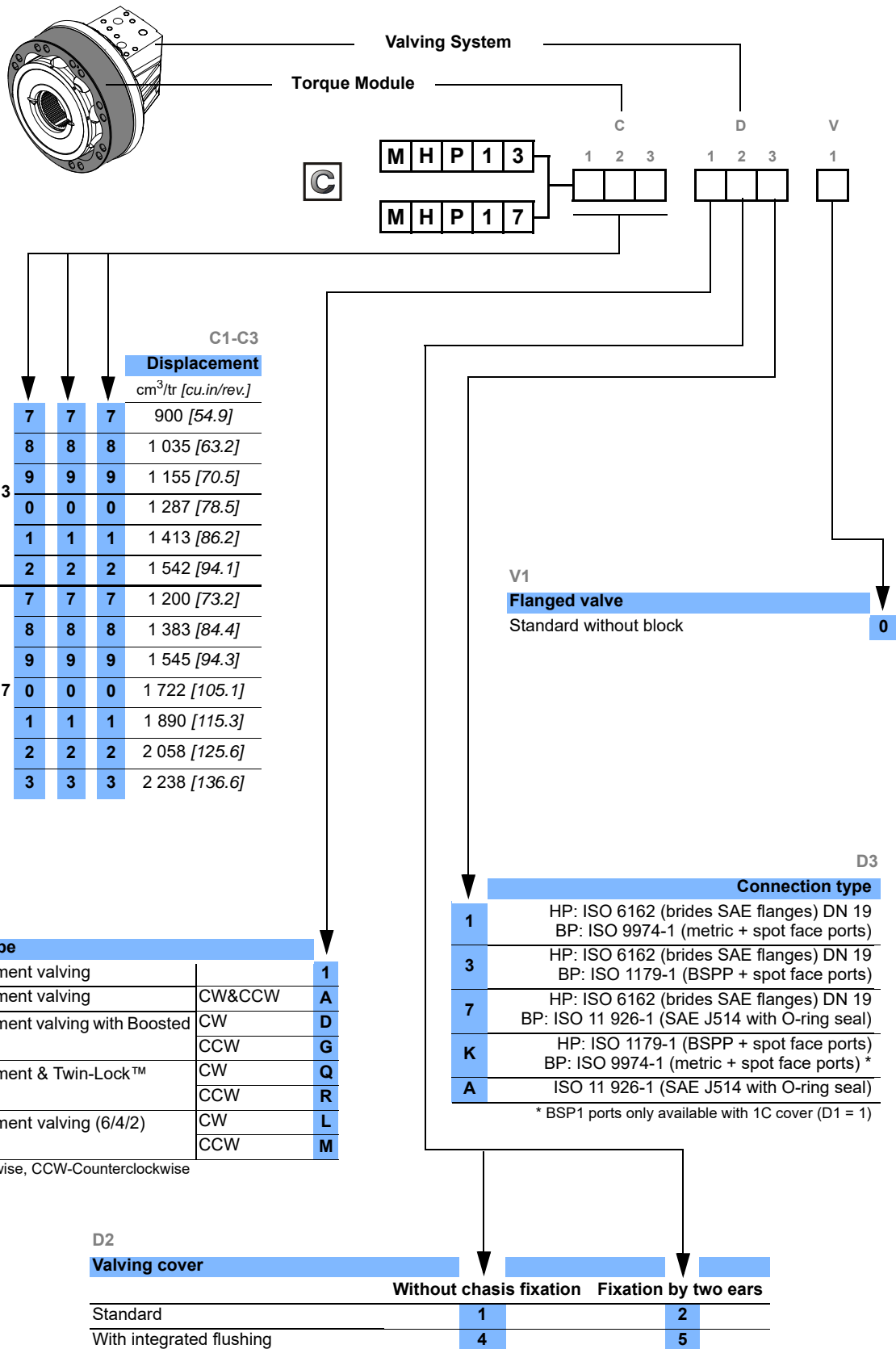



CODE

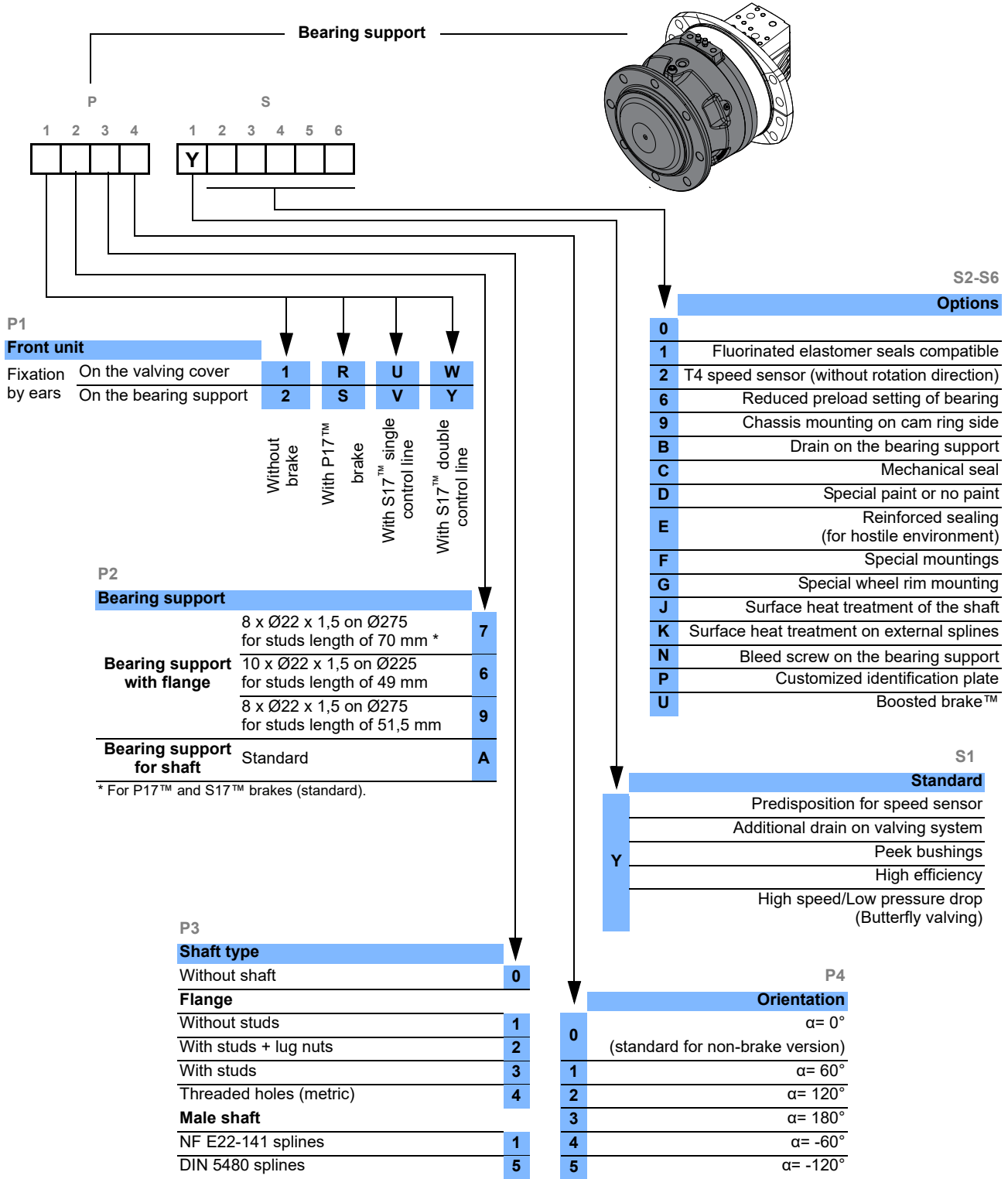

Look at page 35 for more info about motor orientation.

Model code and Modularity

Wheel motor

Wheel motor +S17™ brake

Wheel motor +P17™ brake

Shaft motor

Shaft motor +P17™ brake

Brakes

Installation

Options



MODUL

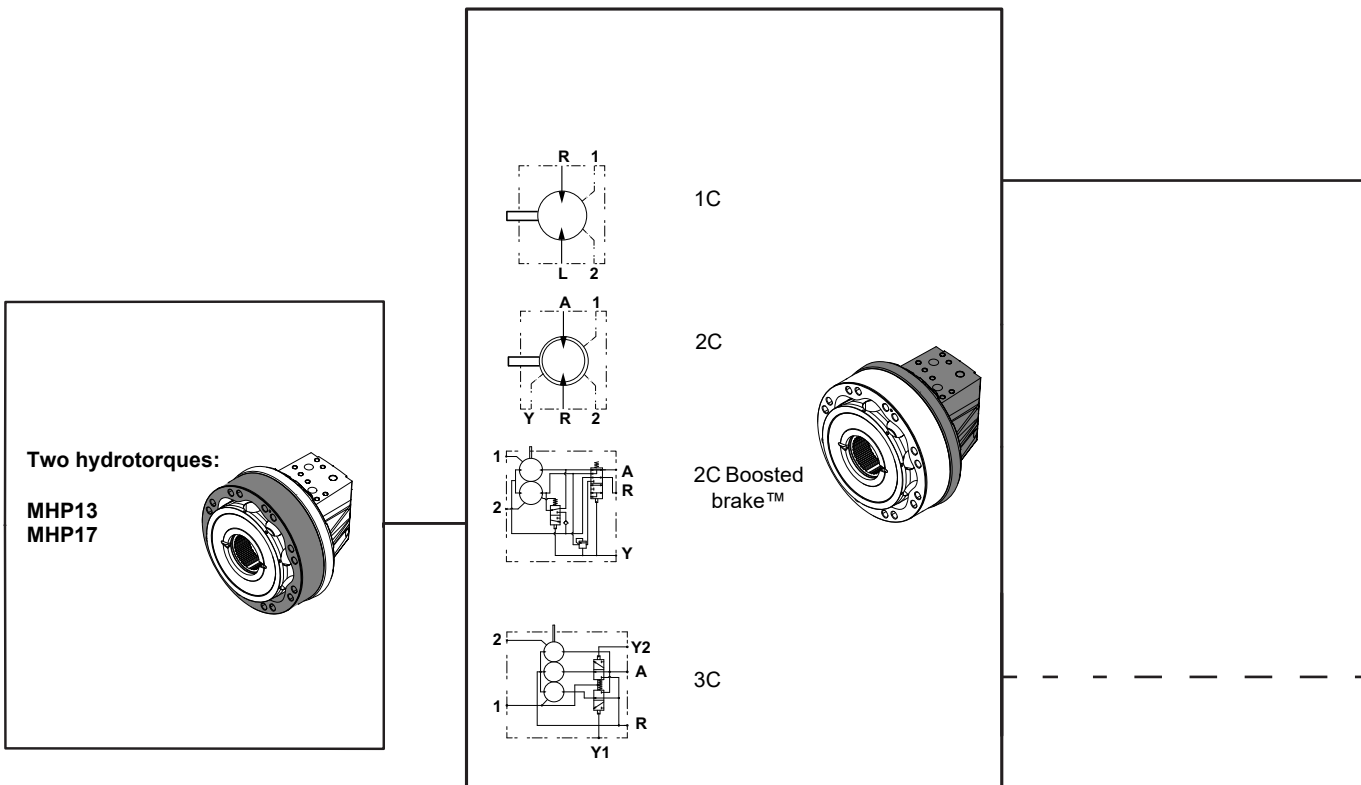



ARITY

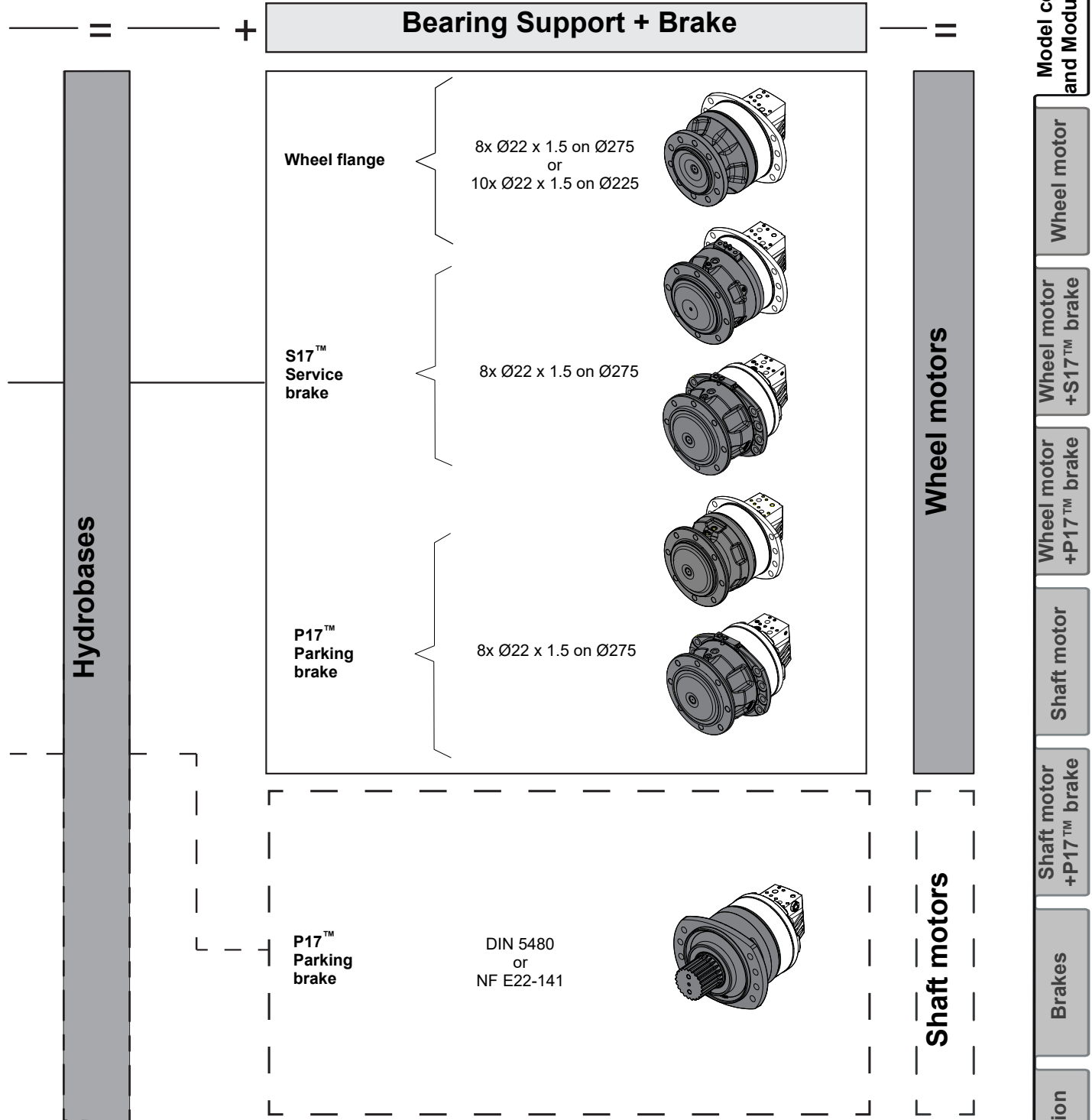



Methodology :

This document is intended for manufacturers of machines that incorporate Poclain Hydraulics products. It describes the technical characteristics of Poclain Hydraulics products and specifies installation conditions that will ensure optimum operation. This document includes important comments concerning safety. They are indicated in the following way:



Safety comment.

This document also includes essential operating instructions for the product and general information. These are indicated in the following way:



Essential instructions.



General information.



Information on the model number.



Weight of component without oil.



Volume of oil.



Units.



Tightening torque.



Screws.



Information intended for Poclain-Hydraulics personnel.

The views in this document are created using metric standards.
The dimensional data is given in mm and in inches (inches are given in brackets in italics).





WHEEL MOTOR

Dimensions for standard (1610) motor

110 kg [242 lb]

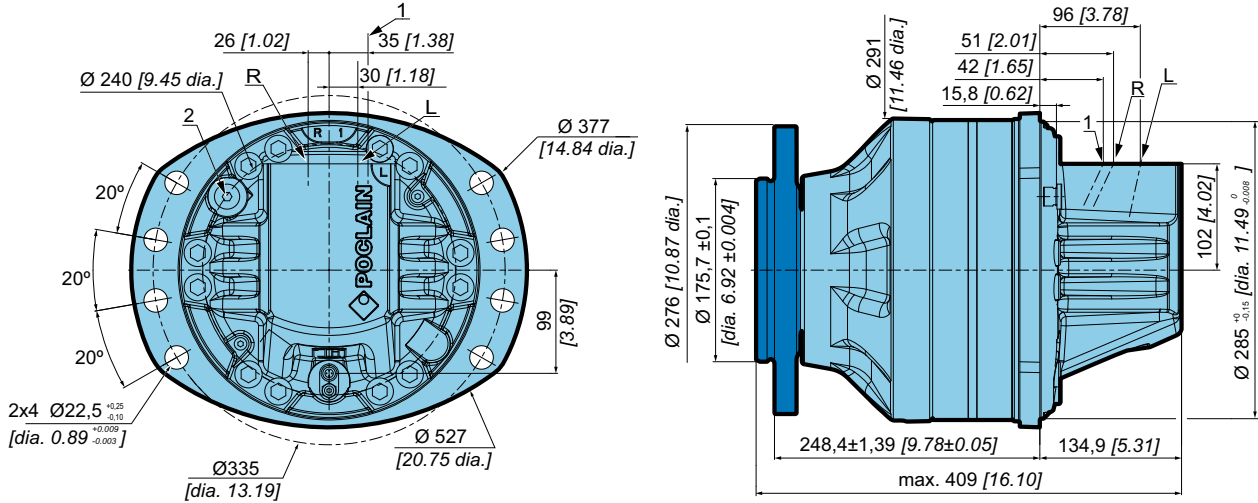

See page 30 for detailed info about hydraulic connections.

Support types

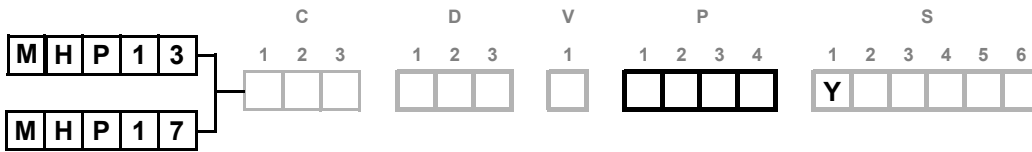

	A	B	C	D	E	N	Wheel rim mountings	L
	mm [in]	mm [in]	mm [in]	mm [in]	mm [in]	mm [in]		mm [in]
	$\varnothing 175.7$ [6,92 dia.]	$\varnothing 225$ [8,86 dia.]	$\varnothing 276$ [10,87 dia.]	252 [9,93]	$\varnothing 291$ [11,46 dia.]	$\varnothing 22$ [0,87 dia.]	10 x M20x1.5	21 [0,83]
	$\varnothing 220.7$ [8,69 dia.]	$\varnothing 275$ [10,83 dia.]	$\varnothing 318$ [12,52 dia.]	248,4 [9,78]	$\varnothing 291$ [11,46 dia.]	$\varnothing 22$ [0,87 dia.]	8 x M20x1.5	19 [0,75]

Studs

		P	C min.	C max.	D		Class
		mm [in]	mm [in]	mm [in]	mm [in]		
Various studs	M20 x 1.5	70 [2,76]	5 [0,20]	26 [1,02]	25,0 [0,98]		12,9
Screws	M20 x 1.5	-	-	-	23,0 [0,91]		10,9



See generic installation motors N°B59689D.

Model code and Modularity

Wheel motor

Wheel motor +S17™ brake

Wheel motor +P17™ brake

Shaft motor

Shaft motor +P17™ brake

Brakes

Installation

Options



Load curves

Permissible radial loads

Test conditions :

Static : 0 tr/min [0 RPM] 0 bar [0 PSI]

Dynamic : 0 tr/min [0 RPM], code 0 displacement, without axial load at max. torque

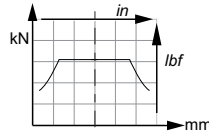

Service life of bearings

Test conditions :

L : Millions B10 revolutions at 150 bars (average pressure), with 25 cSt fluid, code 0 displacement, without axial load.

1 6 1 0
1 2 3 4
P

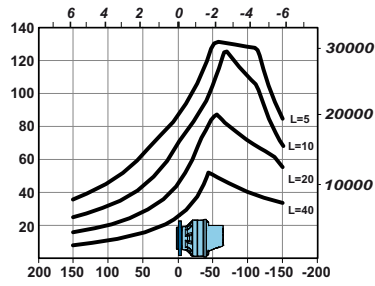
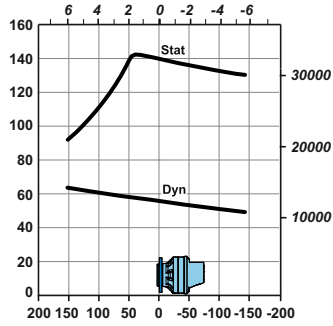

1 9 1 0
1 2 3 4
P

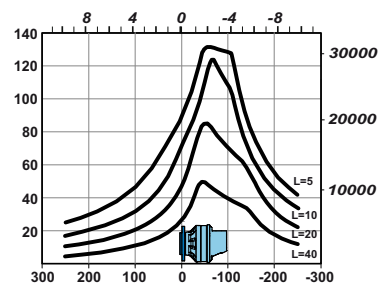
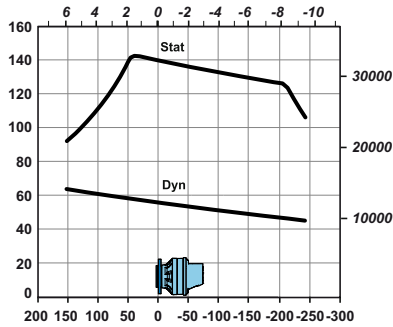

The service life of the components is influenced by the pressure. You must check that the combination of forces applied (Axial load / Radial load) is compatible with the permissible loads for the components, and that the resulting service lives of these components complies with the application's specifications. For an accurate calculation, consult your Poclain Hydraulics application engineer.



Warn the end user in the user documentation to perform an inspection of the shaft after any abnormal shock at wheel.

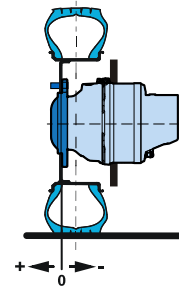



WHEEL MOTOR WITH SERVICE BRAKE

Dimensions for standard (W710) motor

144 kg [317 lb]

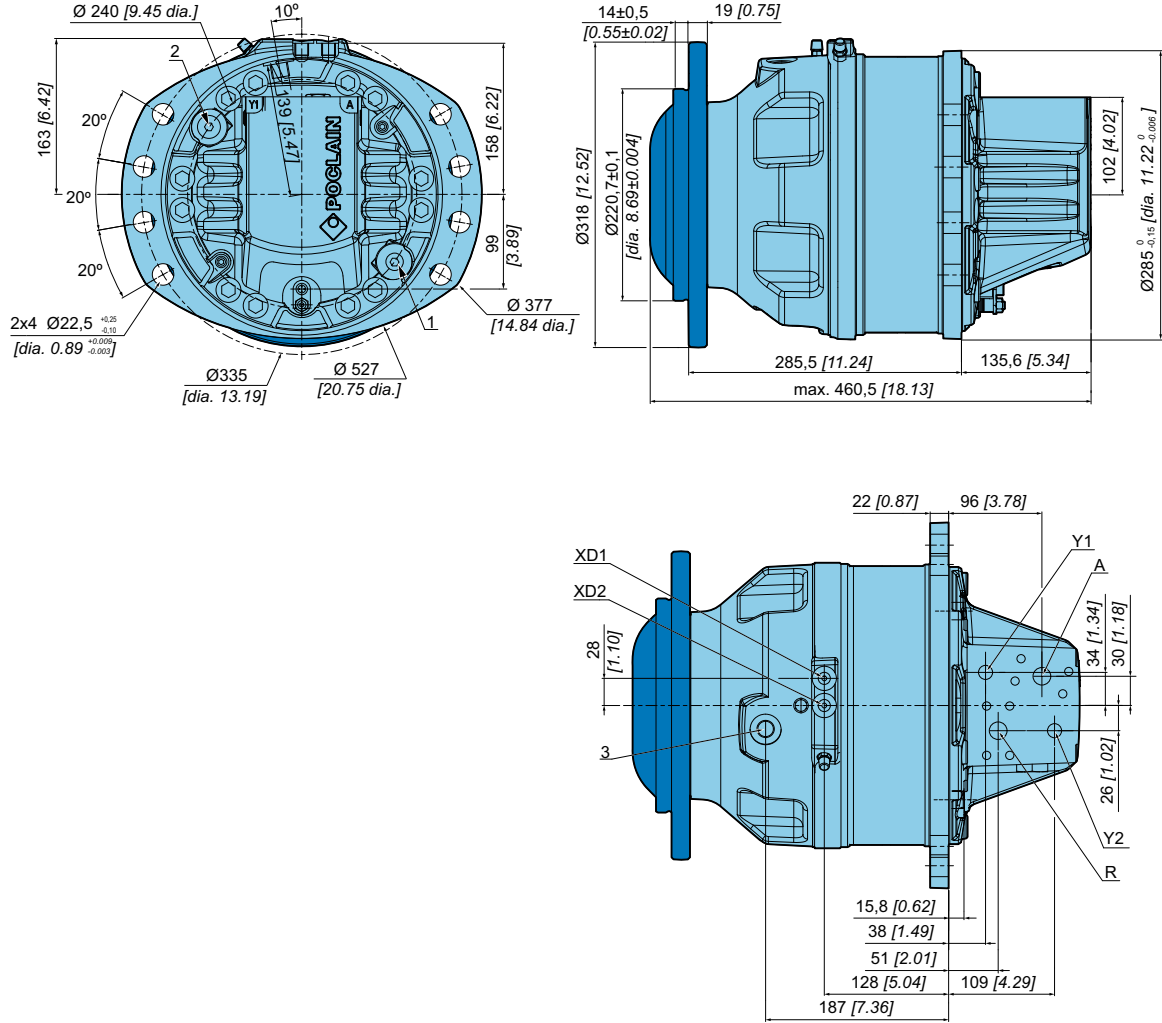

See page 30 for detailed info about hydraulic connections.

Model code and Modularity

Wheel motor

Wheel motor +S17™ brake

Wheel motor +P17™ brake

Shaft motor

Shaft motor +P17™ brake

Brakes

Installation

Options



Dimensions for standard (V710) motor

144 kg [317 lb]

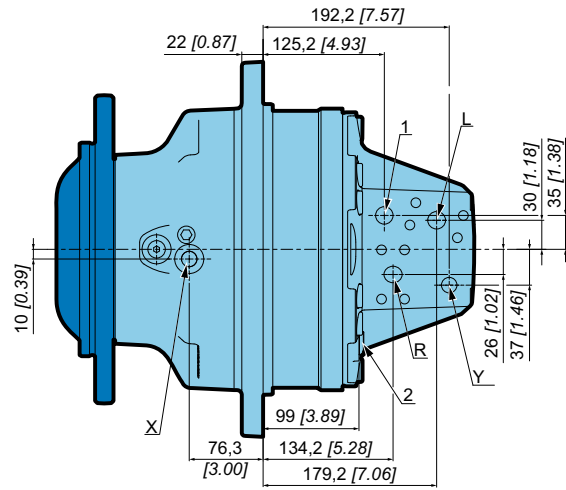
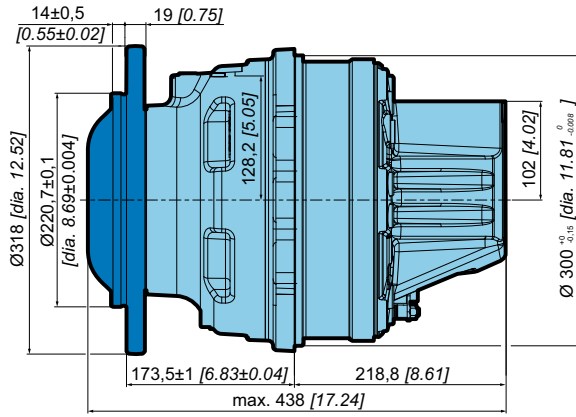
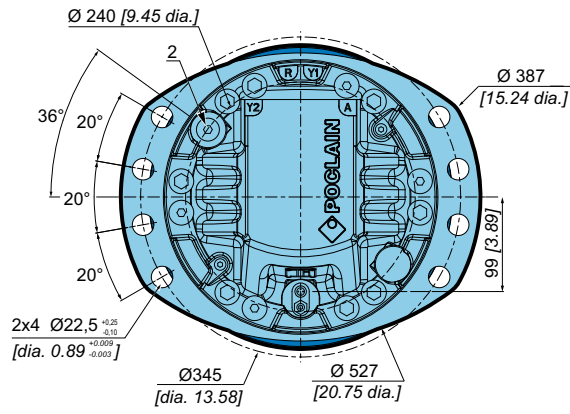

See page 30 for detailed info about hydraulic connections.



Support types



	C	A mm [in]	B mm [in]	C mm [in]	D mm [in]	E mm [in]	N mm [in]	Wheel rim mountings	L mm [in]													
<table border="1"> <tr><td>U</td><td>7</td><td>1</td><td>0</td></tr> <tr><td>W</td><td>7</td><td>1</td><td>0</td></tr> <tr><td>1</td><td>2</td><td>3</td><td>4</td></tr> </table> <p>P</p>	U	7	1	0	W	7	1	0	1	2	3	4		Ø 220,7 [8,69 dia.]	Ø 275 [10,83 dia.]	Ø 318 [12,52 dia.]	285,5 [11,24]	Ø 285 [11,22 dia.]	Ø 22 [0,87 dia.]	8 x M20x1.5	19 [0,75]	
U	7	1	0																			
W	7	1	0																			
1	2	3	4																			
<p>Also see "Brake" section (thumbnail opposite).</p>																						
<table border="1"> <tr><td>V</td><td>7</td><td>1</td><td>0</td></tr> <tr><td>Y</td><td>7</td><td>1</td><td>0</td></tr> <tr><td>1</td><td>2</td><td>3</td><td>4</td></tr> </table> <p>P</p>	V	7	1	0	Y	7	1	0	1	2	3	4		Ø 220,7 [8,69 dia.]	Ø 275 [10,83 dia.]	Ø 318 [12,52 dia.]	173,5 [6,83]	Ø 300 [11,81 dia.]	Ø 22 [0,87 dia.]	8 x M20x1.5	19 [0,75]	
V	7	1	0																			
Y	7	1	0																			
1	2	3	4																			
<p>Also see "Brake" section (thumbnail opposite).</p>																						

Studs

		P mm [in]	C min. mm [in]	C max. mm [in]	D mm [in]		Class
Various studs	M20 x 1.5	70 [2,76]	5 [0,20]	26 [1,02]	25,0 [0,98]		12,9
Screws	M20 x 1.5	-	-	-	23,0 [0,91]		10,9



See generic installation motors N°B59689D.

Model code and Modularity

Wheel motor

Wheel motor +S17™ brake

Wheel motor +P17™ brake

Shaft motor

Shaft motor +P17™ brake

Brakes

Installation

Options



Load curves

Permissible radial loads

Test conditions :

Static : 0 tr/min [0 RPM] 0 bar [0 PSI]

Dynamic : 0 tr/min [0 RPM], code 0 displacement, without axial load at max. torque

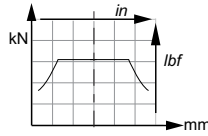

Service life of bearings

Test conditions :

L : Millions B10 revolutions at 150 bars (average pressure), with 25 cSt fluid, code 0 displacement, without axial load.

U	7	1	0
W	7	1	0
1	2	3	4

P

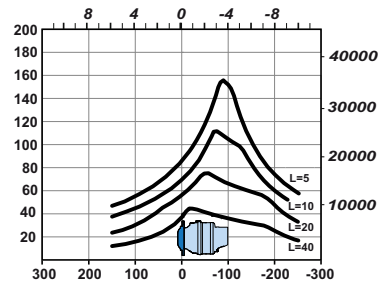
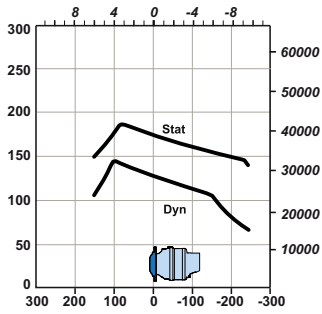

V	7	1	0
Y	7	1	0
1	2	3	4

P

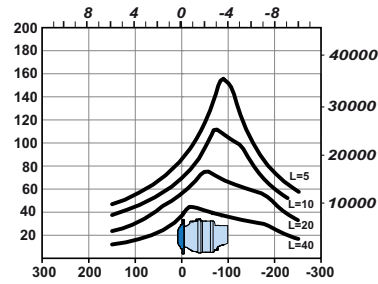
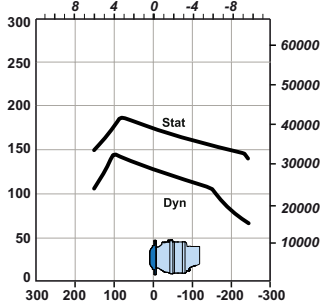

The service life of the components is influenced by the pressure. You must check that the combination of forces applied (Axial load / Radial load) is compatible with the permissible loads for the components, and that the resulting service lives of these components complies with the application's specifications. For an accurate calculation, consult your Poclain Hydraulics application engineer.



Warn the end user in the user documentation to perform an inspection of the shaft after any abnormal shock at wheel.

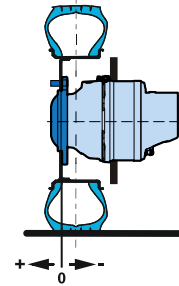



WHEEL MOTOR WITH PARKING BRAKE

Dimensions for standard (R710) motor

140 kg [309 lb]

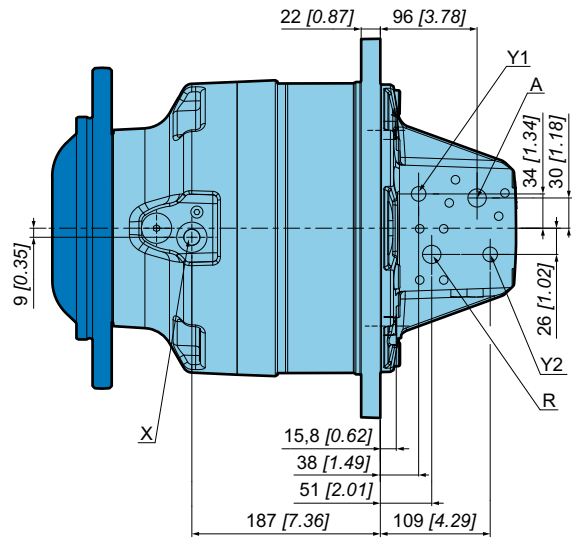
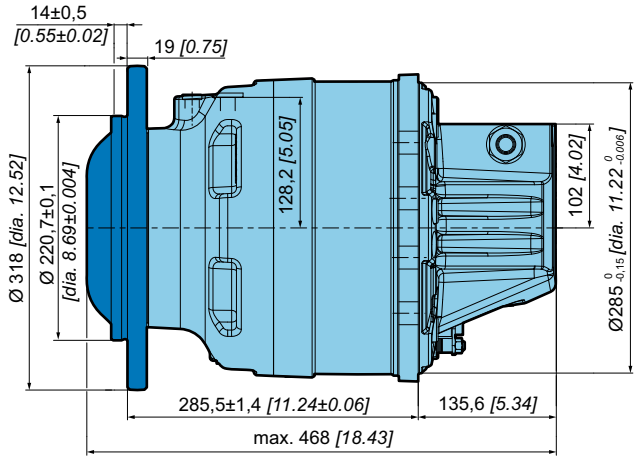
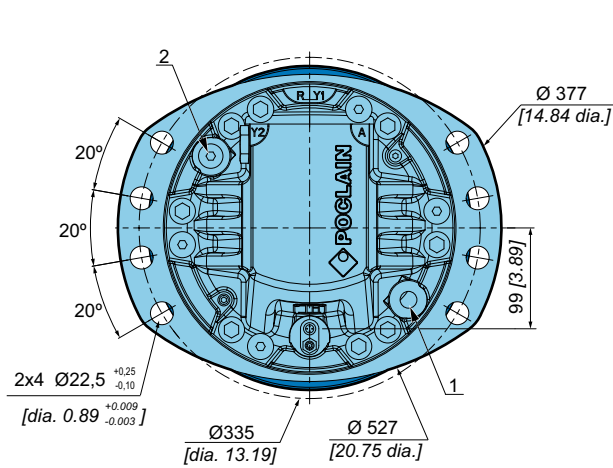

See page 30 for detailed info about hydraulic connections.

Model code and Modularity

Wheel motor

Wheel motor +S17™ brake

Wheel motor +P17™ brake

Shaft motor

Shaft motor +P17™ brake

Brakes

Installation

Options



Dimensions for standard (S710) motor

140 kg [309 lb]

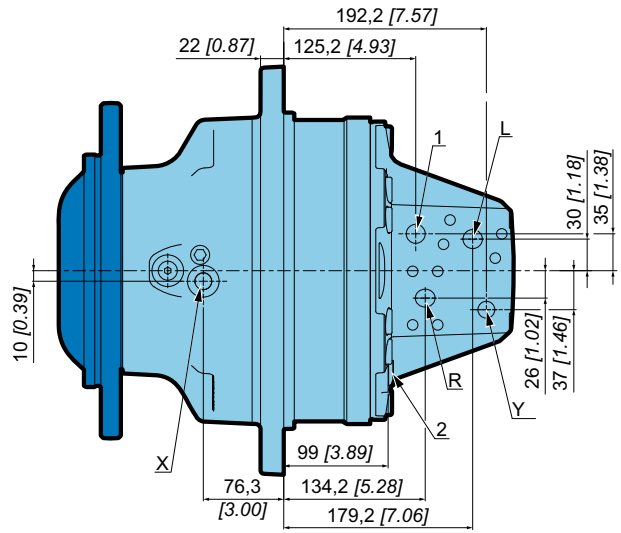
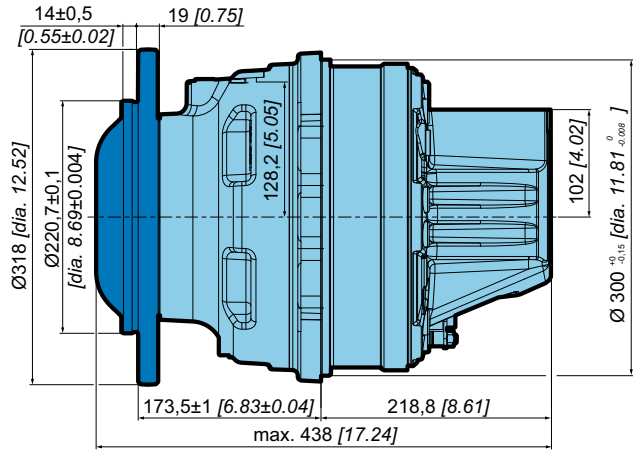
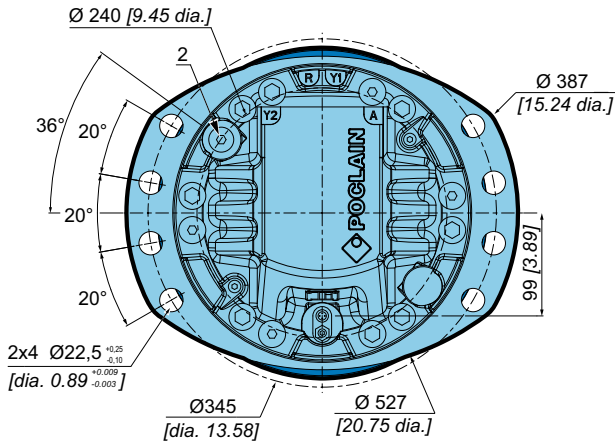

See page 30 for detailed info about hydraulic connections.



Support types

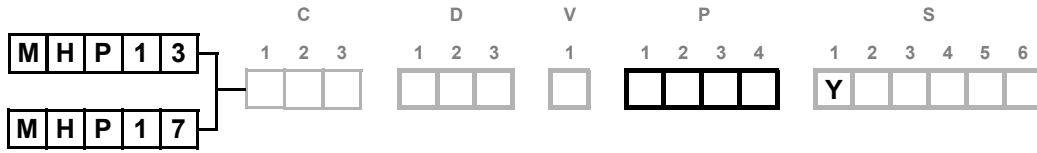

	C	A mm [in]	B mm [in]	C mm [in]	D mm [in]	E mm [in]	N mm [in]	Wheel rim mountings	L mm [in]	
R 7 1 0 1 2 3 4 P		Ø 220,7 [8,69 dia.]	Ø 275 [10,83 dia.]	Ø 318 [12,52 dia.]	285,5 [11,24]	Ø 285 [11,22 dia.]	Ø 22 [0,87 dia.]	8 x M20x1.5	19 [0,75]	
		Also see "Brake" section (thumbnail opposite).								
S 7 1 0 1 2 3 4 P		Ø 220,7 [8,69 dia.]	Ø 275 [10,83 dia.]	Ø 318 [12,52 dia.]	173,5 [6,83]	Ø 300 [11,81 dia.]	Ø 22 [0,87 dia.]	8 x M20x1.5	19 [0,75]	
		Also see "Brake" section (thumbnail opposite).								

Studs

		P mm [in]	C min. mm [in]	C max. mm [in]	D mm [in]		Class
Various studs	M20 x 1.5	70 [2,76]	5 [0,20]	26 [1,02]	25,0 [0,98]		12,9
Screws	M20 x 1.5	-	-	-	23,0 [0,91]		10,9



See generic installation motors N°B59689D.

- Model code and Modularity
- Wheel motor
- Wheel motor +S17™ brake
- Wheel motor +P17™ brake
- Shaft motor
- Shaft motor +P17™ brake
- Brakes
- Installation
- Options



Load curves

Permissible radial loads

Test conditions :

Static : 0 tr/min [0 RPM] 0 bar [0 PSI]

Dynamic : 0 tr/min [0 RPM], code 0 displacement, without axial load at max. torque

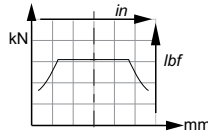

Service life of bearings

Test conditions :

L : Millions B10 revolutions at 150 bars (average pressure), with 25 cSt fluid, code 0 displacement, without axial load.

R 7 1 0
1 2 3 4
P

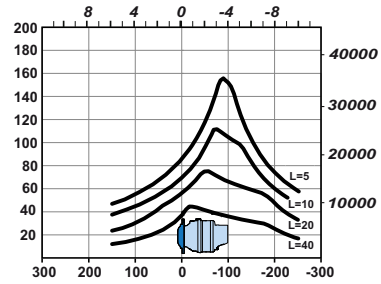
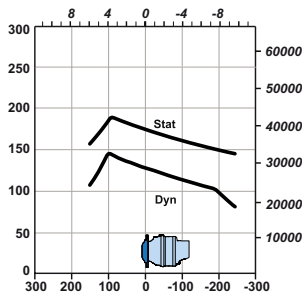

S 7 1 0
1 2 3 4
P

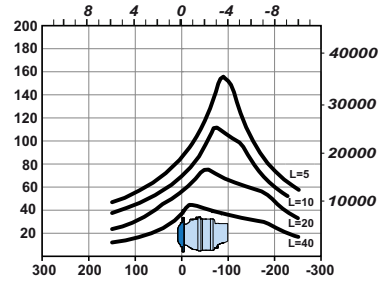
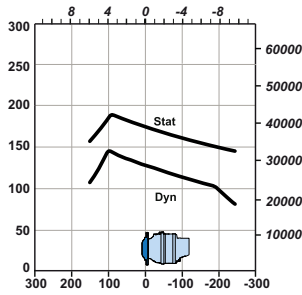

The service life of the components is influenced by the pressure. You must check that the combination of forces applied (Axial load / Radial load) is compatible with the permissible loads for the components, and that the resulting service lives of these components complies with the application's specifications. For an accurate calculation, consult your Poclair Hydraulics application engineer.



Warn the end user in the user documentation to perform an inspection of the shaft after any abnormal shock at wheel.

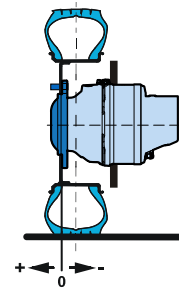



SHAFT MOTOR

Dimensions for standard (2A10 / 2A50) motor

96 kg [212 lb]

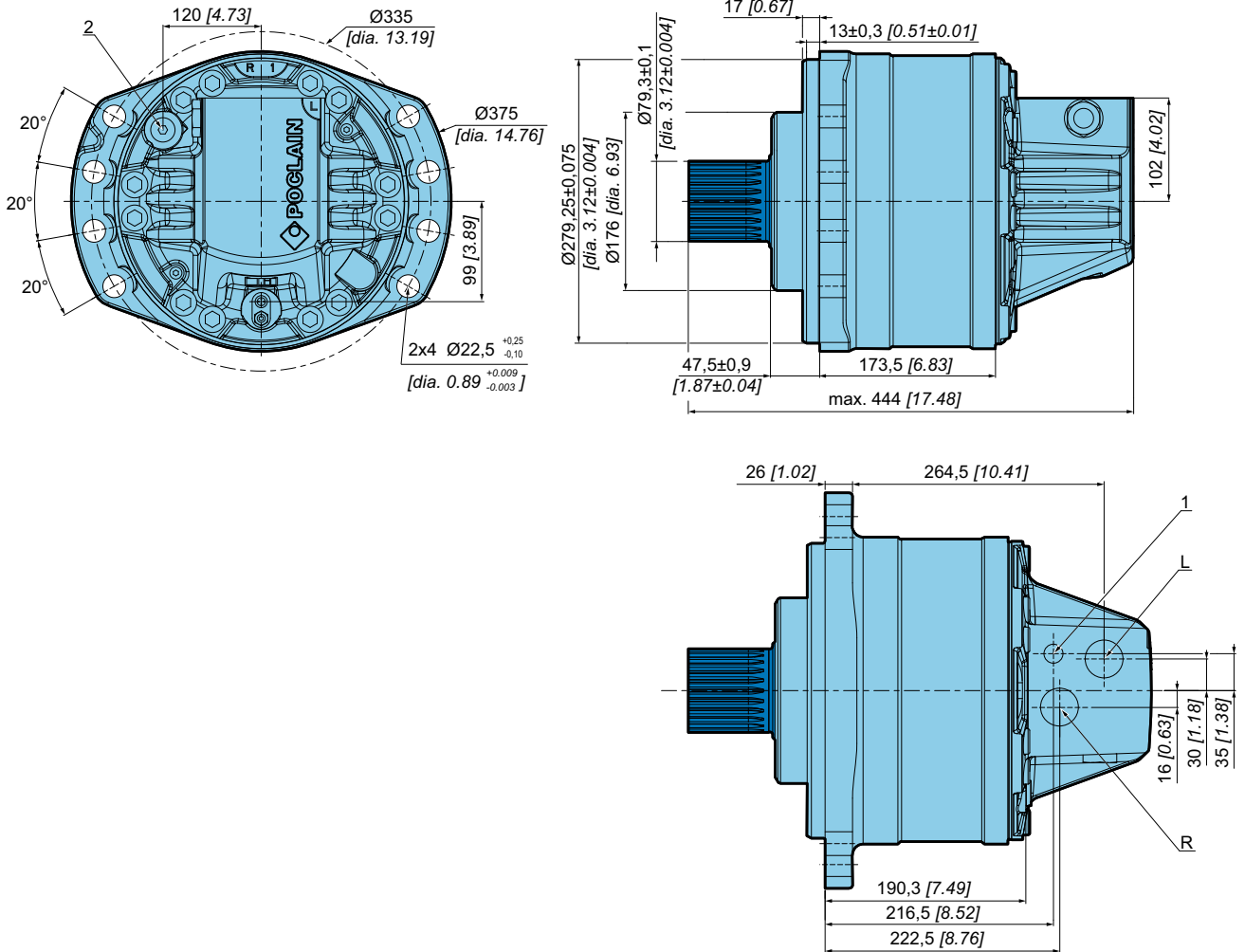

See page 30 for detailed info about hydraulic connections.

Model code and Modularity

Wheel motor

Wheel motor +S17™ brake

Wheel motor +P17™ brake

Shaft motor

Shaft motor +P17™ brake

Brakes



Installation

Options

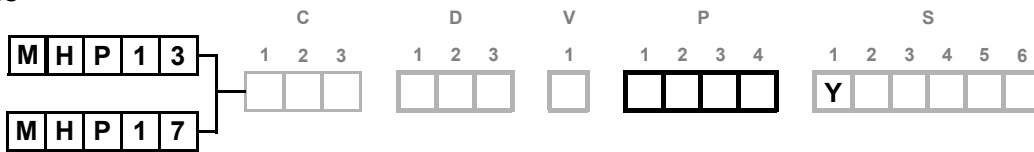

Support types



		A	B	C	D	E	F
		mm [in]	mm [in]	mm [in]	mm [in]	mm [in]	mm [in]
C NF E22-141 splines 2 A 1 0 <small>1 2 3 4</small> P Nominal Ø 75 [2,95] Module 2,5 Z 25	 Also see "Brake" section (thumbnail opposite).	14 [0,55]	R 3 [R 0,12]	35 [1,38]	2 x M10	23 [0,91]	80 [3,15]
		C DIN 5480 splines 2 A 5 0 <small>1 2 3 4</small> P Nominal Ø 80 [3,15] Module 3 Z 25	 Also see "Brake" section (thumbnail opposite).	14 [0,55]	R 3 [R 0,12]	35 [1,38]	2 x M10

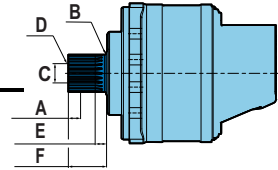

 **Also see 'Valving systems and hydrobases' section**
(thumbnail opposite).

Splined coupling

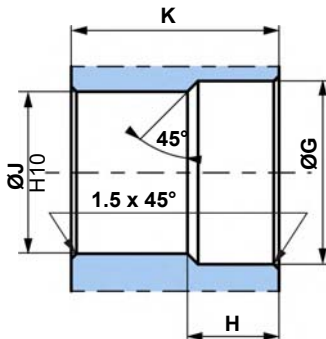

N : Nominal Ø.
Mo : Module.
Z : Number of teeth.

Standard DIN 5480
Pressure angle 30°. Centering on flanks. Slide fit (7H quality).

Standard NF E22-141
Pressure angle 20°. Centering on flanks. Slide fit (7H quality).

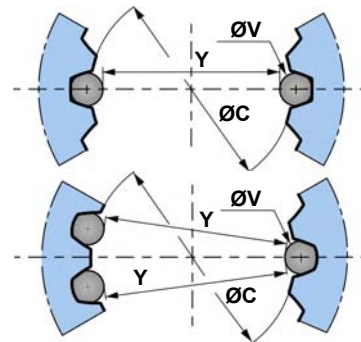

		Ø G	H	Ø J	K	N	Mo	Z	Offset	Ø C (H10)	Ø V	Y	Tolerance µm [µin]
C 2 A 1 0 <small>1 2 3 4</small> P	76 [2.99]	25 [0.98]	70 [2.76]	69 [2.72]	75 [2.95]	2.5	28	2 [0.08]	70 [2.76]	5 [0.20]	65.169 [2.57]	+ 103 / 0 [+4.055 / 0]	
													C 2 A 5 0 <small>1 2 3 4</small> P

General tolerances: ± 0.25 [±0.0098].

Material: Ex: 42CrMo4.

Hardening treatment to obtain R = 800 to 900 N/mm² [R = 116 030 to 130 533 PSI].



Load curves

Permissible radial loads

Test conditions :

Static : 0 tr/min [0 RPM] 0 bar [0 PSI]

Dynamic : 0 tr/min [0 RPM], code 0 displacement, without axial load at max. torque

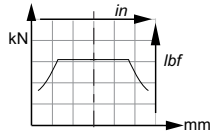

Service life of bearings

Test conditions :

L : Millions B10 revolutions at 150 bars (average pressure), with 25 cSt fluid, code 0 displacement, without axial load.

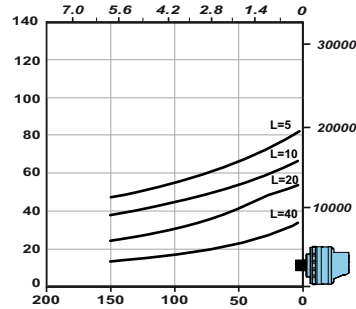
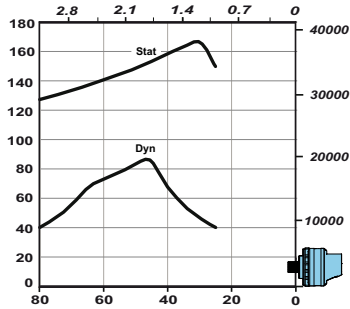
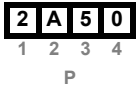
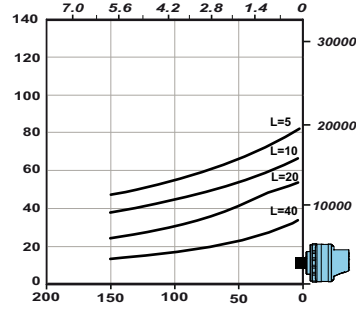
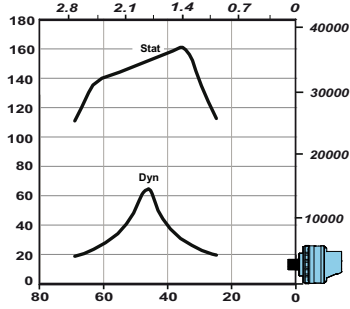
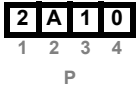

The service life of the components is influenced by the pressure. You must check that the combination of forces applied (Axial load / Radial load) is compatible with the permissible loads for the components, and that the resulting service lives of these components complies with the application's specifications. For an accurate calculation, consult your Poclair Hydraulics application engineer.

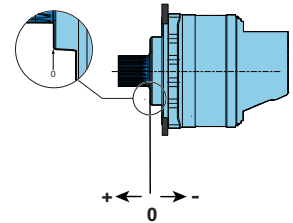

Model code and Modularity

Wheel motor

Wheel motor +S17™ brake

Wheel motor +P17™ brake

Shaft motor

Shaft motor +P17™ brake

Brakes

Installation

Options



SHAFT MOTOR WITH PARKING BRAKE

Dimensions for standard (SA10 / SA50) motor

144 kg [317 lb]

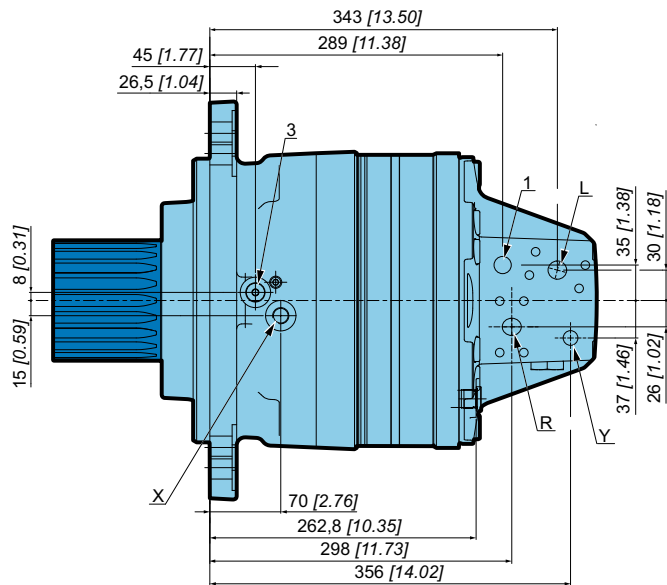
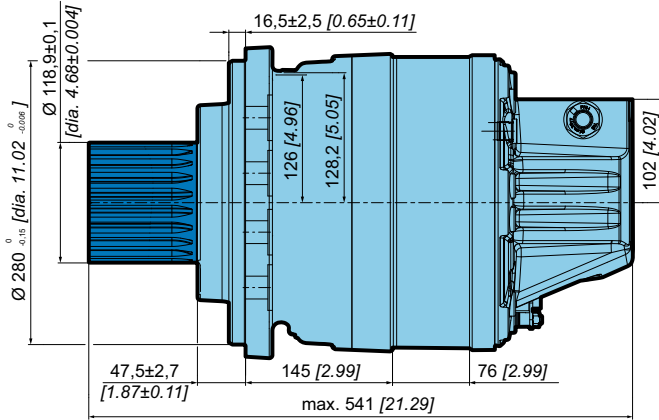
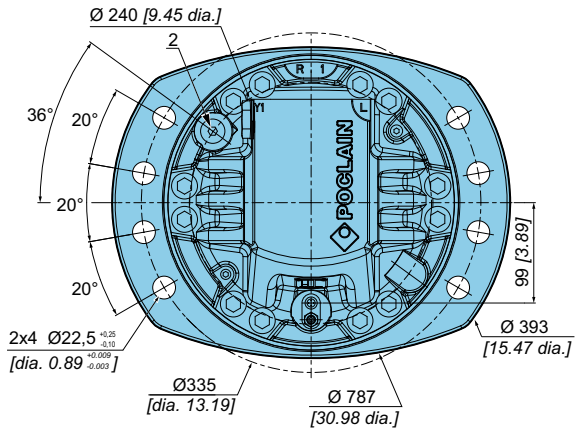

See page 30 for detailed info about hydraulic connections.



Support types

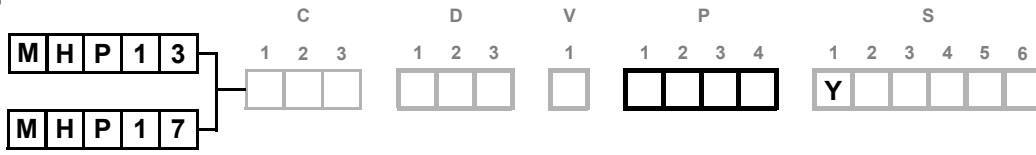

	A	B	C	D	E	F
	mm [in]	mm [in]	mm [in]	mm [in]	mm [in]	mm [in]
NF E22-141 splines						
Nominal Ø	120 [4,72]	R 3	60	2 x M16	28	110
Module	3,75	[R 0,12]	[2,36]		[1,10]	[4,33]
Z	30					
Also see "Brake" section (thumbnail opposite).						
DIN 5480 splines						
Nominal Ø	120 [4,72]	R 3	60	2 x M16	28	110
Module	5	[R 0,12]	[2,36]		[1,10]	[4,33]
Z	22					
Also see "Brake" section (thumbnail opposite).						
Also see 'Valving systems and hydrobases' section (thumbnail opposite).						

Splined coupling

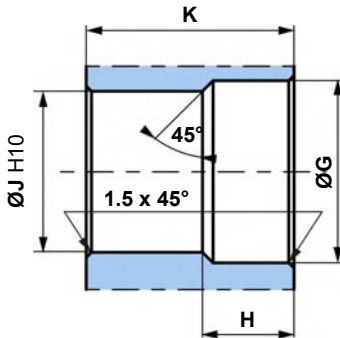

Standard NF E22-141

Pressure angle 20°.
Centering on flanks.
Slide fit (7H quality).

Standard DIN 5480

Pressure angle 30°.
Centering on flanks.
Slide fit (7H quality).

N : Nominal Ø.
Mo : Module.
Z : Number of teeth.

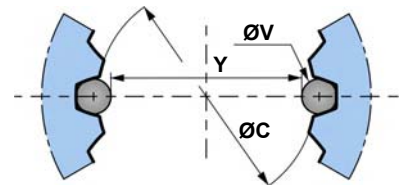

	Ø G	H	Ø J	K	N	Mo	Z	Offset	Ø C (H10)	Ø V	Y	Tolerance
	mm [in]	mm [in]	mm [in]	mm [in]	mm [in]			mm [in]	mm [in]	mm [in]	mm [in]	µm [µin]
NF E22-141	121	29	113	109	120	3,75	30	3,00	112,5	7,5	105,253	+ 104 / 0
	[4,76]	[1,14]	[4,43]	[4,29]	[4,72]			[0,12]	[4,43]	[0,30]	[4,14]	[+4.094 / 0]
DIN 5480	122	29	110	109	120	5	22	2,25	110	9	101,104	+ 87 / 0
	[4,80]	[1,14]	[4,33]	[4,29]	[4,72]			[0,09]	[4,33]	[0,35]	[3,98]	[+3.425 / 0]

General tolerances: ± 0.25 [±0.0098].

Material: Ex: 42CrMo4.

Hardening treatment to obtain R = 800 to 900 N/mm² [R = 116 030 to 130 533 PSI].

Model code and Modularity

Wheel motor

Wheel motor +S17™ brake

Wheel motor +P17™ brake

Shaft motor

Shaft motor +P17™ brake

Brakes

Installation

Options



Load curves

Permissible radial loads

Test conditions :

Static : 0 tr/min [0 RPM] 0 bar [0 PSI]

Dynamic : 0 tr/min [0 RPM], code 0 displacement, without axial load at max. torque

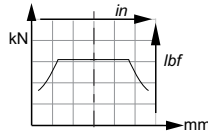

Service life of bearings

Test conditions :

L : Millions B10 revolutions at 150 bars (average pressure), with 25 cSt fluid, code 0 displacement, without axial load.

S	A	1	0
S	A	5	0
1	2	3	4

P

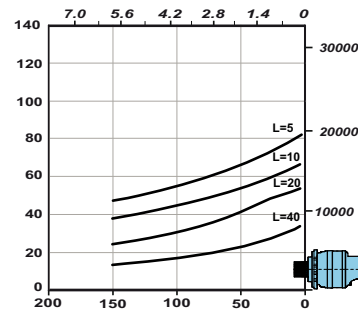
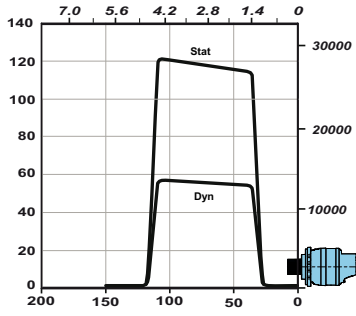

The service life of the components is influenced by the pressure. You must check that the combination of forces applied (Axial load / Radial load) is compatible with the permissible loads for the components, and that the resulting service lives of these components complies with the application's specifications. For an accurate calculation, consult your Poclain Hydraulics application engineer.

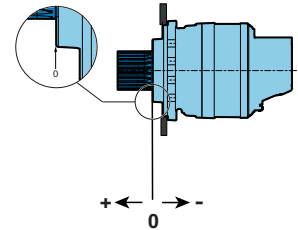



BRAKES

S17™ Service brake

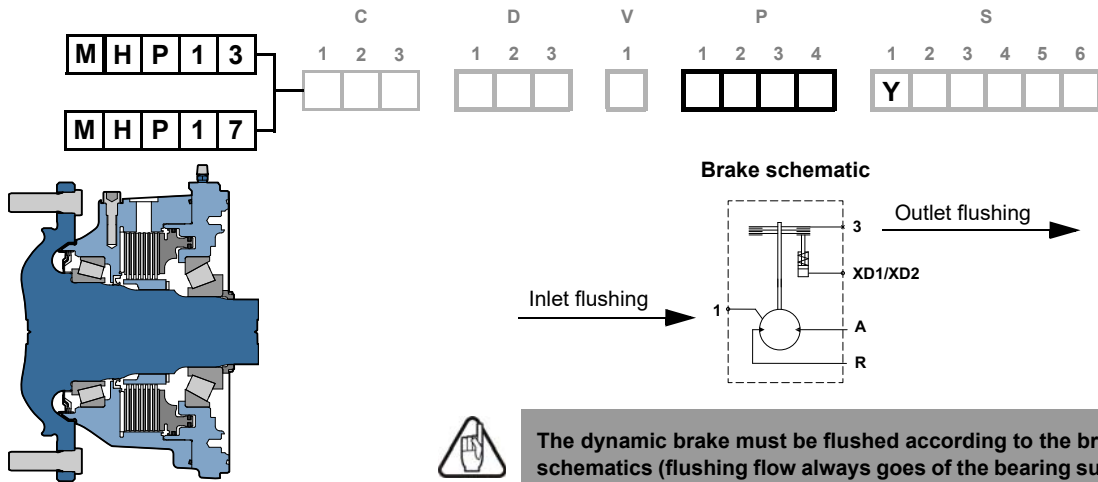

The dynamic brake must be flushed according to the brake schematics (flushing flow always goes of the bearing support).

Brake operation

This multi-disc brake is activated by a braking pressure (dynamic braking). The braking command creates a pressure on the dynamic braking piston, which damps the fixed and free discs, preventing the shaft from turning. Braking torque increases linearly as a function of the piloting pressure.

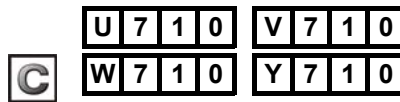

General information

Max. rotation speed	220 rpm
Max. energy dissipation for 1 braking (maintenance needed)	995 kJ

Dynamic brake information

Average torque during dynamic braking	22 000 Nm [16 230 lb.ft]
Pressure to obtain max. permissible braking	120 bar [1 740 PSI]
Piston chamber piloting volume, worn brake	91 cm³ [5,6 cu.in]
Service brake max. allowed energy	480 kJ

S17™ wheel flange flushing graph

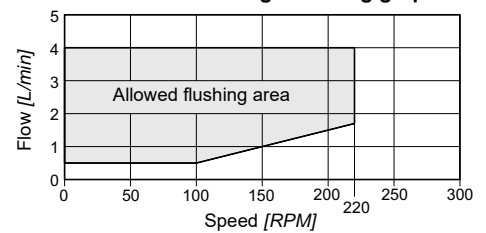

- Brake S17™ requires mandatory flushing.
- Brake release pressure vented.
- The use of certain oils may not offer the characteristics stated above. Consult your Poclain Hydraulics application engineer.
- When using the Boosted brake™ option, the S17™ bearing support might not be able to withstand the combination of maximum hydrostatic torque and maximum service brake torque. Please contact your Poclain Hydraulics application engineer for a detailed calculation.
- It is essential to connect the brake valve return line directly to the tank. Any counterpressure on the return brake line can cause premature brake wear without any use of the pedal.
- Service brake declared data are only valuable for decreasing energy brakings.

Model code and Modularity

Wheel motor

Wheel motor +S17™ brake

Wheel motor +P17™ brake

Shaft motor

Shaft motor +P17™ brake

Brakes

Installation

Options



P17™ Parking brake

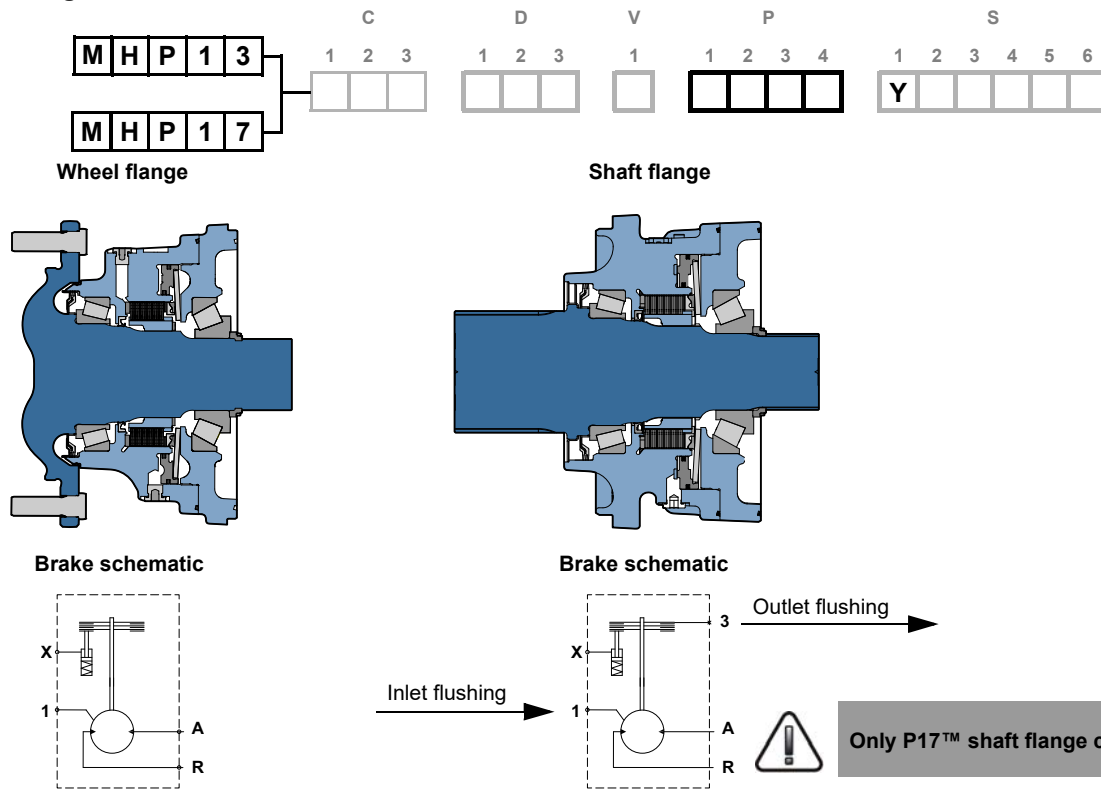

Brake operation

This is a multidisc brake which is activated by a lack of pressure. The spring exerts a force on the piston, which presses on the fixed and mobile discs, and immobilizes the shaft. The braking torque decreases in linear proportion to the brake release pressure.

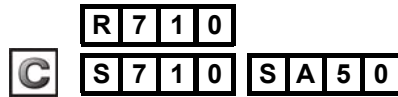

	Wheel flange	Shaft flange
Max. rotation speed	220 rpm	300 rpm
Max. energy dissipation	225 kJ	
Number of parking brake applications	1 000 000	
Release brake pressure (min/max)	16 [232] / 30 [435]	
Min. parking brake torque	16 000 Nm [11 800 lb.ft]	
Min. static brake torque (after emergency braking)	15 600 Nm [11 510 lb.ft]	
Min. dynamic brake torque in case of emergency brake with new brake	14 000 Nm [10 330 lb.ft]	

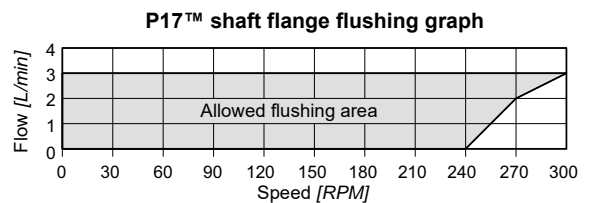

Do not run-in the multidisc brakes.



A functional check of the parking brake must be carried out each time it is used as an auxiliary brake (or emergency brake). For all vehicles capable of speeds over 25 km/h, please contact your Poclair Hydraulics application engineer.



The use of certain oils may not offer the characteristics stated above. Consult your Poclair Hydraulics application engineer.



When using the Boosted brake™ option, the P17™ bearing support might not be able to withstand the combination of maximum hydrostatic torque and maximum service brake torque. Please contact your Poclair Hydraulics application engineer for a detailed calculation.



Boosted brake™

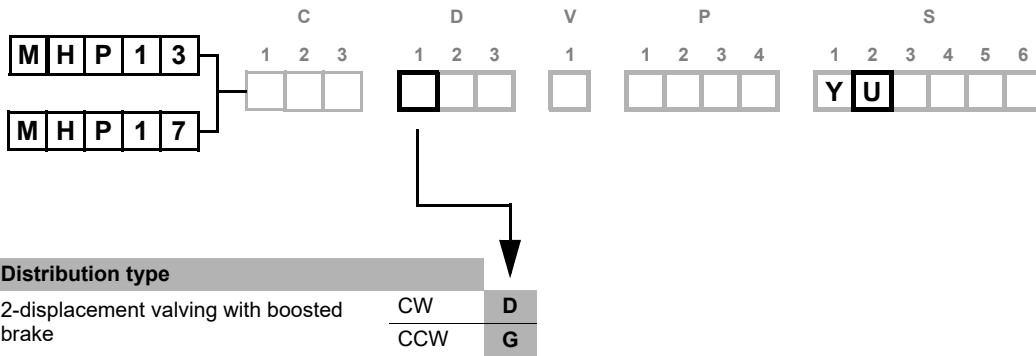

Why Boosted brake™ function?

Boosted brake™ provides increased hydrostatic braking capabilities. It enables regulation requirements to be met in terms of braking distances, whilst reducing the use of the friction brakes. Boosted brake™ complements the diesel engine's retardation capacity. It also avoids engine over-speed when braking.

Using the principles of hydrostatic braking through the hydraulic motor's entire displacement capacity and not just the partial displacement that is active when braking occurs, it converts the machine's kinetic energy into heat in the oil in the hydrostatic transmission system. This heat is then evacuated in the cooler.

Boosted brake™ is especially interesting for all machines subject to high and/or repeated deceleration, both on the road and in the field. It is recommended for machines with diesel engines with a low retardation capacity.



The braking is more efficient and engine is preserved: that is an essential point to ensure the lifetime of the machine.

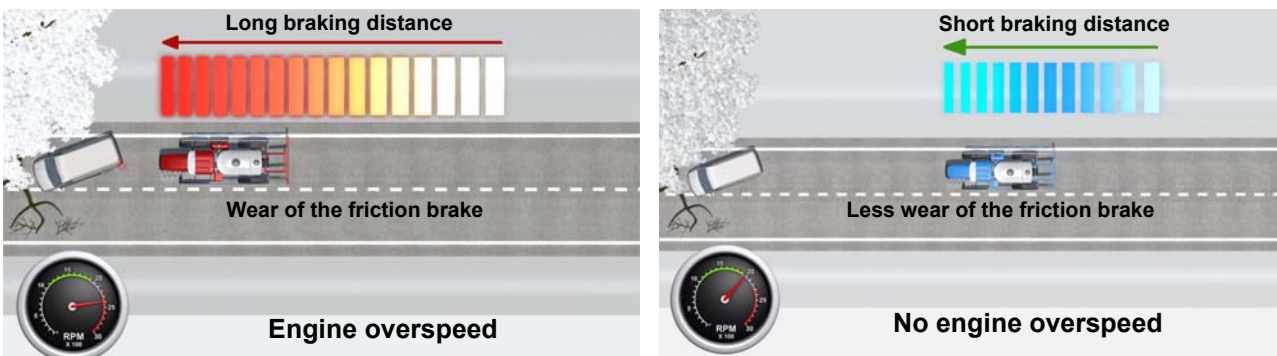

Consult your Poclair Hydraulics application engineer.

Model code and Modularity

Wheel motor

Wheel motor +S17™ brake

Wheel motor +P17™ brake

Shaft motor

Shaft motor +P17™ brake

Brakes

Installation

Options





INSTALLATION

Customer's chassis and wheel rim mountings

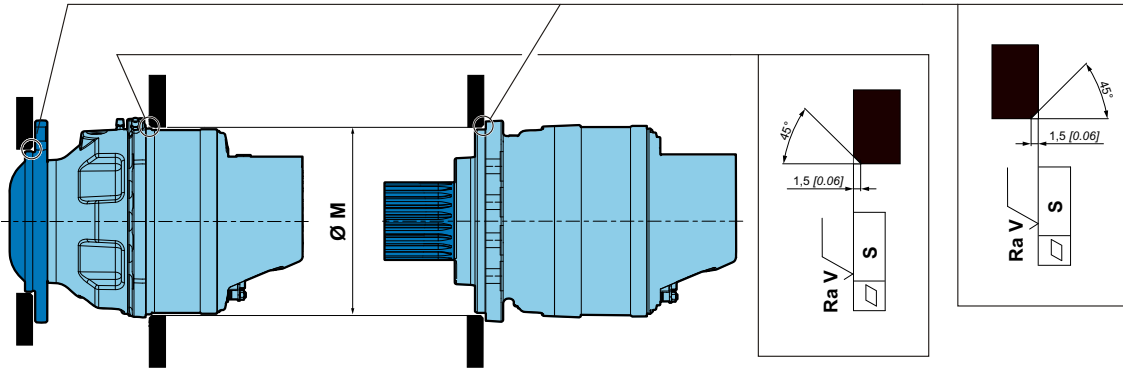

Take care over the immediate environment of the connections.

		Ø M ⁽¹⁾ mm [in]	S mm [in]	Ra V µm [µin]		Class (min)																																												
<table border="1"> <tr><td colspan="4">P</td></tr> <tr><td>1</td><td>2</td><td>3</td><td>4</td></tr> <tr><td>1</td><td></td><td></td><td></td></tr> <tr><td>S</td><td>7</td><td></td><td></td></tr> <tr><td>R</td><td>7</td><td></td><td></td></tr> <tr><td>U</td><td>7</td><td></td><td></td></tr> </table>	P				1	2	3	4	1				S	7			R	7			U	7			<table border="1"> <tr><td colspan="4">P</td></tr> <tr><td>1</td><td>2</td><td>3</td><td>4</td></tr> <tr><td>V</td><td>7</td><td></td><td></td></tr> <tr><td>W</td><td>7</td><td></td><td></td></tr> <tr><td>Y</td><td>7</td><td></td><td></td></tr> </table>	P				1	2	3	4	V	7			W	7			Y	7			385 [15.16]	0,2 [0.008]	12,5 [0.492]	2 x 4 M20 x 2,5	10/9
P																																																		
1	2	3	4																																															
1																																																		
S	7																																																	
R	7																																																	
U	7																																																	
P																																																		
1	2	3	4																																															
V	7																																																	
W	7																																																	
Y	7																																																	
<table border="1"> <tr><td colspan="4">P</td></tr> <tr><td>1</td><td>2</td><td>3</td><td>4</td></tr> <tr><td>S</td><td>A</td><td></td><td></td></tr> </table>	P				1	2	3	4	S	A				440 [17.32]																																				
P																																																		
1	2	3	4																																															
S	A																																																	
<table border="1"> <tr><td colspan="4">P</td></tr> <tr><td>1</td><td>2</td><td>3</td><td>4</td></tr> <tr><td>2</td><td>A</td><td></td><td></td></tr> </table>	P				1	2	3	4	2	A				290.0 [11.42]																																				
P																																																		
1	2	3	4																																															
2	A																																																	

(1) +0.3 [+0.000]
+0.2 [+0.000]



You are strongly advised to use the fluids specified in brochure "Installation guide" N° B59689D.



To find the connections' tightening torques, see the brochure "Installation guide" N° B59689D.



For more information see the brochure "Installation guide" N°B61352L .

Model code
and Modularity

Wheel motor

Wheel motor
+S17™ brake

Wheel motor
+P17™ brake

Shaft motor

Shaft motor
+P17™ brake

Brakes

Installation

Options



Hydraulic connections

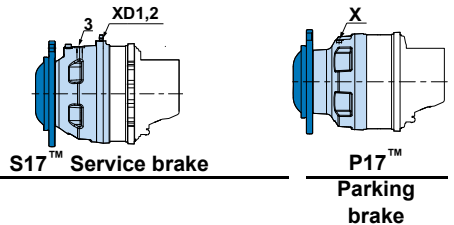
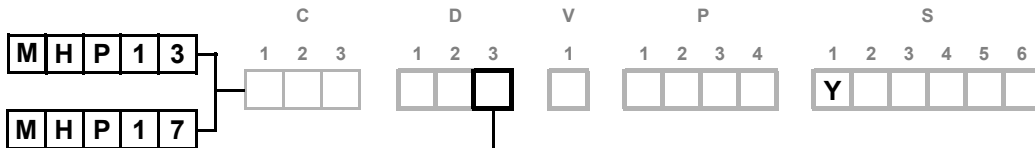

	Standards		Power supply		Standards		Case drain	2 nd , 3 rd displacement	Control of service brake	Control of service brake	Control of parking brake	Control of parking brake
			R-L				1-2		XD 1	XD 2	3	X
1 st Displacement	1	ISO 6162	SAE 6000PSI 3/4"		ISO 9 974-1		M 18x15		M 14x15	M 14x15	M 18x15	M 16x15
	3	ISO 6162	SAE 6000PSI 3/4"		ISO 1179		BSP 3/8		BSP 1/4	BSP 1/4	BSP 3/8	BSP 3/8
	7	ISO 6162	SAE 6000PSI 3/4"		ISO 11 926		7/8"-14 UNF		9/16"-18 UNF	9/16"-18 UNF	3/4"-16 UNF	9/16"-18 UNF
	K	ISO 1179-1	34G - G1		ISO 9974-1		M 18x15		BSP 1/4	BSP 1/4	BSP 3/8	BSP 3/8
	A	ISO 6162	1" 5/16-12 UNF		ISO 11 926		M 18x15		9/16"-18 UNF	9/16"-18 UNF	3/4"-16 UNF	9/16"-18 UNF
2 nd Displacement	1	ISO 6162	SAE 6000PSI 3/4"		ISO 9 974-1		M 18x15	M 16x15	M 14x15	M 14x15	M 18x15	M 16x15
	3	ISO 6162	SAE 6000PSI 3/4"		ISO 1179		BSP 3/8	BSP 3/8	BSP 1/4	BSP 1/4	BSP 3/8	BSP 3/8
	7	ISO 6162	SAE 6000PSI 3/4"		ISO 11 926		7/8"-14 UNF	3/4"-16 UNF	9/16"-16 UNF	9/16"-18 UNF	3/4"-16 UNF	9/16"-18 UNF
	A	ISO 6162	1" 1/16-12 UNF		ISO 11 926		M 18x15	3/4"-16 UNF	9/16"-18 UNF	9/16"-18 UNF	3/4"-16 UNF	9/16"-18 UNF
				R	A 1-A2			1-2	Y	XD 1	XD 2	3
Twin-Lock™	1	ISO 6162	SAE 6000PSI 3/4"	SAE 6000PSI 3/4"	ISO 9 974-1		M 22x15	M 16x15	M 16x15	M 14x15	M 22x15	M 16x15
	3	ISO 6162	SAE 6000PSI 3/4"	SAE 6000PSI 3/4"	ISO 1179		BSP 3/8	BSP 3/8	BSP 1/4	BSP 1/4	BSP 3/8	BSP 3/8
	7	ISO 6162	SAE 6000PSI 3/4"	SAE 6000PSI 3/4"	ISO 11 926		7/8"-14 UNF	3/4"-16 UNF	9/16"-18 UNF	9/16"-18 UNF	3/4"-16 UNF	9/16"-18 UNF
3 rd Displacement	1	ISO 6162	SAE 6000PSI 3/4"		ISO 9 974-1		M 18x15	M 16x15	M 14x15	M 14x15	M 18x15	M 16x15
	3	ISO 6162	SAE 6000PSI 3/4"		ISO 1179		BSP 3/8	BSP 3/8	BSP 1/4	BSP 1/4	BSP 3/8	BSP 3/8
	7	ISO 6162	SAE 6000PSI 3/4"		ISO 11 926		7/8"-14 UNF	3/4"-16 UNF	9/16"-18 UNF	9/16"-18 UNF	3/4"-16 UNF	9/16"-18 UNF
	A	ISO 6162	1" 1/16-12 UNF		ISO 11 926		M 18x15	3/4"-16 UNF	9/16"-18 UNF	9/16"-18 UNF	3/4"-16 UNF	9/16"-18 UNF
				R-A				1-2	Y1-Y2	XD 1	XD 2	3

Max pressure	bar [PSI]	500 [7 250]	1 [14.5]	30 [435]	120 [1740]	120 [1740]	30 [435]



Valving cover orientation

MHP13	C	D	V	P	S
MHP17	1 2 3	1 2 3	1	1 2 3 4	1 2 3 4 5 6
	1	2	3	4	Y

Distribution angular deviation [°]	
0° *	0
60°	1
120°	2
180°	3
-60°	4
-120°	5

* Standard for motors without brake.

1: Reference axis:
supply orifice of braking bearing support

2: Axis on cover: supply orifices axis

α : Angle between ports on the bearing support (brake) and ports on the cover (power supply)

Motor orientation and balancing during handling

MHP13	C	D	V	P	S
MHP17	1 2 3	1 2 3	1	1 2 3 4	1 2 3 4 5 6
	1	2	3	4	Y



Use R port connections for motor orientation and balancing during handling.

Model code and Modularity

Wheel motor

Wheel motor +S17™ brake

Wheel motor +P17™ brake

Shaft motor

Shaft motor +P17™ brake

Brakes

Installation

Options



Speed shifting logic

2 displacements motor

	Y1
1 st displacement	0
2 nd displacement	1

3 displacements motor

	Y1	Y2
1 st displacement	1	0
2 nd displacement	0	0
3 rd displacement	0	1



It's prohibited to pilot Y1 and Y2 at the same time while using 3-displacement valving.



OPTIONS

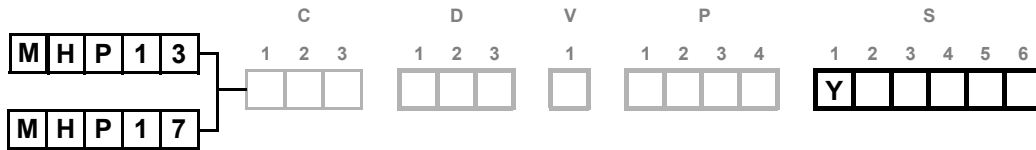

Y Standard option

- Predisposition for speed sensor
- Case flushing (additional drain on the valving cover)
- High efficiency (piston with special ring)
- High speed/Low pressure drop (Butterfly valving)

1 Fluorinated elastomer seals

Compatible with C and D fluids.



Consult your Poclain Hydraulics sales engineer.

2 Installed speed sensor

Designation

T4 speed sensor installed (without rotation direction)



2

A-A

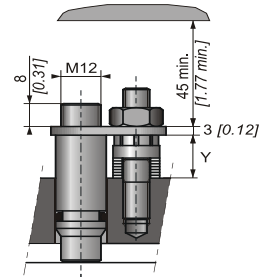

Max. length Y = 21,5 [0.85]

Standard number of pulses per revolution = 80

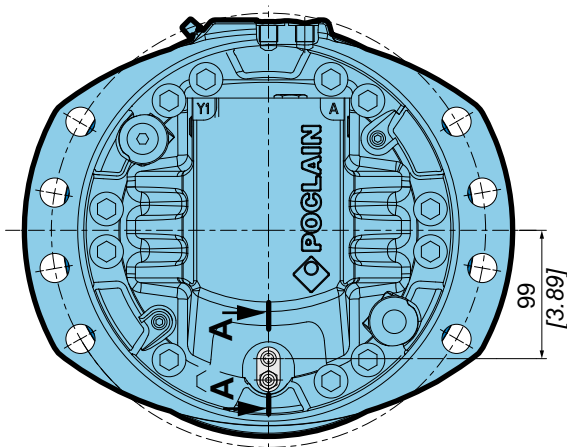

Look at the "Mobile Electronic" N° A01889D technical catalogue for the sensor specifications and its connection.



To install the sensor, see the brochure "Installation guide" No. B61352L.

Model code and Modularity

Wheel motor

Wheel motor +S17™ brake

Wheel motor +P17™ brake

Shaft motor

Shaft motor +P17™ brake

Brakes

Installation

Options



6 Reduced preload setting of bearing

Reduction of around 50% from the rated value in the bearings' preload value. Without external loads, increases the lifetime of the bearing support.



For a precise calculation, consult your Poclain Hydraulics application engineer.

9 Chassis mounting on cam ring side

Only available for shaft motors.

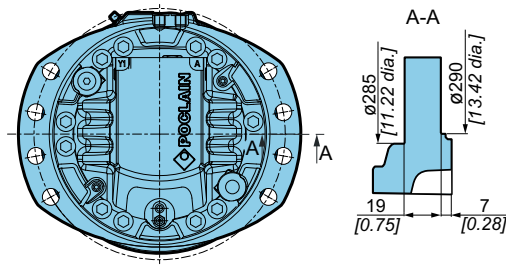

B Drain on the bearing support

Only available for shaft motors.

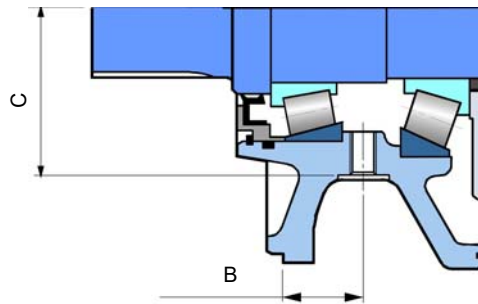

		B mm [in]	C mm [in]
Shaft motor	M18x1,5	60 [2.36]	128,2 [5.05]

C Abrasive environments

Some environments can be very harmful. The mirror seal gives reinforced motor sealing.

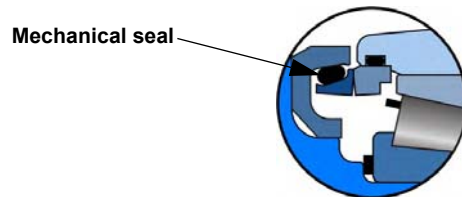

Consult your Poclain Hydraulics sales engineer.



D Special paint or no paint

The motors are delivered with Poclain Hydraulics yellow ochre primer as standard.



Consult your Poclain Hydraulics application engineer for other colors of primer or topcoat.

E Reinforced sealing

For free-wheeling by pressure.

G Special wheel rim mounting

Enables certain combinations different from the standard mountings defined on page 9.



Consult your Poclain Hydraulics application engineer.

J Surface heat treatment of the shaft

Heat treatment on the indicated bearing raius.

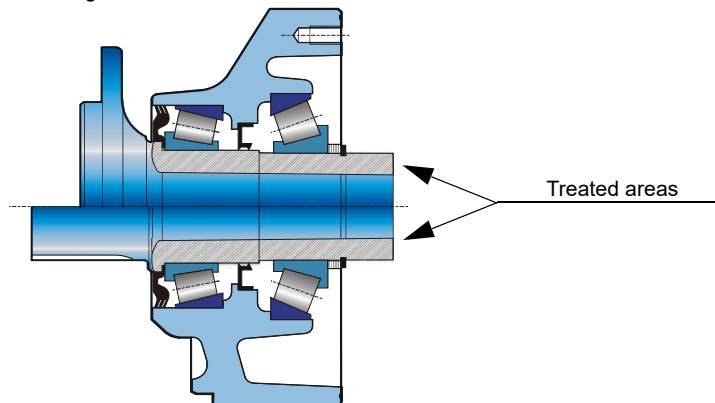

K Surface heat treatment on external splines

N Bleed screw on the bearing support

P Name plate specific to the customer

Your part number can be engraved on the plate.



Consult your Poclain Hydraulics application engineer for other possibilities.

F Special mountings

U Boosted brake™



Consult your Poclain Hydraulics application engineer (see page 27).

Model code and Modularity

Wheel motor

Wheel motor +S17™ brake

Wheel motor +P17™ brake

Shaft motor

Shaft motor +P17™ brake

Brakes

Installation

Options



Poclain Hydraulics reserves the right to make any modifications it deems necessary to the products described in this document without prior notification. The information contained in this document must be confirmed by Poclain Hydraulics before any order is submitted.

Illustrations are not binding.

The Poclain Hydraulics brand is the property of Poclain Hydraulics S.A.

-  02/07/2024
-  Not available
-  B44851A
-  Not available
-  Not available
-  Not available
-  Not available
-  Not available
-  Not available

