



Visit our homepage for additional support parker.com/pmde

MSG30-5510-M1/UK

Service/ Spare Parts Manual Series V14

Effective: November, 2023

Supersedes: March, 2023

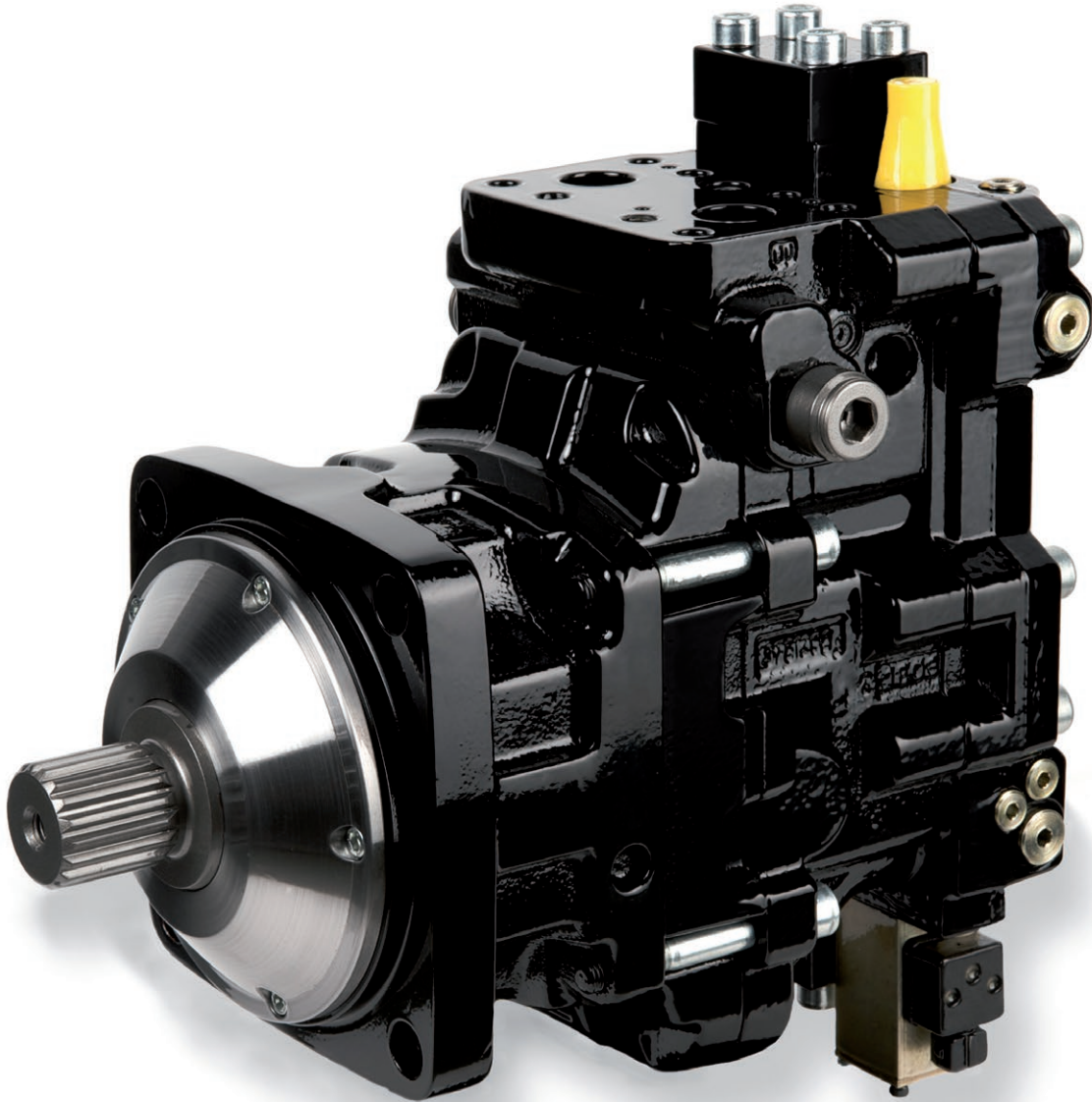

ENGINEERING YOUR SUCCESS.

List of contents	Page
General Information/New features V14.....	3
Specifications / cross section.....	4
Displacement limiter.....	5 – 6
Ordering code.....	7
Installation.....	8 – 9
Controls and gauge ports.....	10 – 16
Displacement limiter.....	17
Disassembling.....	18 – 22
Assembling.....	23 – 27
Control spring kit and filter.....	28
Split Views V14- 110/- 160.....	30
Spare Parts V14- 110/- 160.....	31 – 33
Split views AC/AH; HO/HP/HPC and EO/EP/EPC Control.....	34
Spare parts AC/AH; HO/HP/HPC and EO/EP/EPC Control.....	35 – 36
Split View A-module.....	37
Test procedure.....	38

Conversion factors

1 kg	=	2.2046 lb
1 N	=	0.22481 lbf
1 bar	=	14.504 psi
1 l	=	0.21997 UK gallon
1 l	=	0.26417 US gallon
1 cm ³	=	0.061024 in ³
1 m	=	3.2808 feet
1 mm	=	0.03937 in
1 °C	=	1.8 °F + 32

General information

Series V14 is a new generation of variable displacement motors developed and manufactured by Parker Hannifin, Pump and Motor Division.

The V14 is a further development of our well known V12 motor. It is designed for both open and closed circuits, intended particularly for mobile applications.

New features:

- Increased shaft speeds
- Improved sealing
- Faster control response
- Improved shaft support
- Additional integrated functions added
- New control, HPC, for winch

...mainly thanks to:

- Re-designed piston
- O-ring seals between housings
- Enlarged setting piston
- Increased size control device
- Tapered roller bearings

Important features carried over from previous motors:

- Operating pressures to 480 bar
- High speeds, thanks to low weight pistons with laminated piston rings and a very compact design of rotating parts.
- High overall efficiency throughout the entire displacement range
- 9 pistons provide high start-up torque and smooth operation
- Wide displacement range – 5:1
- Small envelope size and high power-to-weight ratio
- Low noise levels due to the compact, sturdy design and smooth fluid passages
- Positive piston locking, strong synchronizing shaft, heavy-duty bearings and a small number of parts add up to a very robust motor with long service life and proven reliability.

Specifications

V14 Frame size	110	160
Displacement (cm³/rev)		
at 35° (max)	110	160
at 6,5° (min)	22	32
Operating Pressure (bar)		
max intermittent ¹⁾	480	480
max continuous	420	420
Operating speed (rpm)		
max intermittent at 35° ¹⁾	3900	3400
max continuous at 35°	3400	3000
max intermittent at 6.5° – 20° ¹⁾	6500	5700
max continuous at 6.5° – 20°	5700	5000
min continuous	50	50
Flow (l/min)		
max intermittent ¹⁾	430	550
max continuous	375	480
Output torque (Nm) at 100 bar (theor.)	175	255
Max output power (kW)	262	335
Corner power (kW)		
max intermittent ¹⁾	570	730
continuous	440	560
Mass moment of inertia (x10⁻³) [kg m²]	8.2	14.5
Weight (kg)	54	68

¹⁾ Max 6 seconds in any one minute

V14 cross section

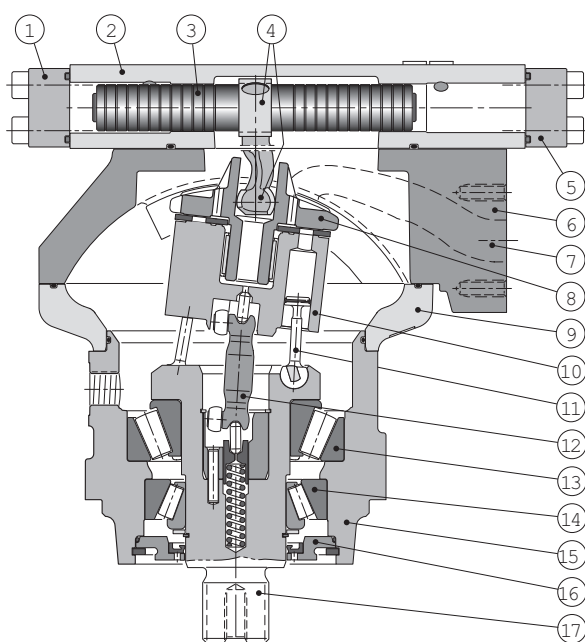

1. End cover, min displ.
2. Control module
3. Setting piston
4. Connecting arm
5. End cover, max displ.
6. Connection module
7. Main pressure port
8. Valve segment
9. Intermediate housing
10. Cylinder Barrel
11. Spherical piston with laminated piston ring
12. Synchronizing shaft
13. Inner roller bearing
14. Outer roller bearing
15. Bearing housing
16. Shaft seal with retainer
17. Output shaft

Displacement limiter V14-110

Setting angle [degree]	Displacement [cm ³ /varv]	Shim maximum side [mm]	Shim minimum side [mm]	Setting angle [degree]	Displacement [cm ³ /varv]	Shim maximum side [mm]	Shim minimum side [mm]
6,5	22	58,5	9,5	20,4	67	32,0	35,5
6,9	23	58	10,0	20,8	68	32,5	36,0
7,2	24	57,5	10,5	21,1	69	31,0	37,0
7,5	25	57,0	11,0	21,4	70	30,0	37,5
7,8	26	56,0	11,5	21,7	71	29,5	38,0
8,1	27	55,5	12,0	22,1	72	29,0	39,0
8,4	28	55,0	12,5	22,4	73	28,0	39,5
8,7	29	54,5	13,0	22,7	74	27,5	40,0
9,0	30	54,0	13,5	23,0	75	27,0	41,0
9,3	31	53,5	14,0	23,3	76	26,0	41,5
9,6	32	53,0	15,0	23,7	77	25,5	42,0
9,9	33	52,5	15,5	24,0	78	25,0	43,0
10,2	34	52,0	16,0	24,3	79	24,0	43,5
10,5	35	51,5	16,5	24,7	79	24,0	43,5
10,8	36	51,0	17,0	25,0	81	23,0	45,0
11,1	37	50,0	17,5	25,3	82	22,0	45,5
11,4	38	49,5	18,0	25,6	83	21,0	46,5
11,7	39	49,0	18,5	26,0	84	20,5	47,0
12,0	40	48,5	19,0	26,3	85	20,0	48,0
12,3	41	48,0	20,0	26,6	86	19,0	48,5
12,7	42	47,5	20,5	27,0	87	18,5	49,5
13,0	43	46,5	21,0	27,3	88	17,5	50,0
13,3	44	46,0	21,5	27,7	89	17,0	51,0
13,6	45	45,5	22,0	28,0	90	16,0	51,5
13,9	46	45,0	22,5	28,3	91	15,0	52,5
14,2	47	44,5	23,0	28,7	92	14,5	53,0
14,5	48	44,0	24,0	29,0	93	13,5	54,0
14,8	49	43,0	24,5	29,4	94	13,0	55,0
15,1	50	42,5	25,0	29,7	95	12,0	55,5
15,4	51	42,0	25,5	30,0	96	11,0	56,5
15,7	52	41,5	26,0	30,4	97	10,5	57,5
16,0	53	41,0	27,0	30,7	98	9,5	58,0
16,4	54	40,5	27,5	31,1	99	9,0	59,0
16,7	55	40,0	28,0	31,4	100	8,0	60,0
17,0	56	39,0	28,5	31,8	101	7,0	60,5
17,3	57	38,5	29,0	32,1	102	3,0	61,5
17,6	58	38,0	30,0	32,5	103	5,5	62,5
17,9	59	37,0	30,5	32,8	104	4,5	63,5
18,2	60	36,5	31,0	33,2	105	3,5	64,0
18,5	61	35,5	32,5	33,6	106	2,5	65,0
18,9	62	35,5	32,5	33,9	107	1,5	66,0
19,2	63	34,5	33,0	34,3	108	0,5	67,0
19,5	64	34,0	33,5	34,5	109	0,0	68,0
19,8	65	33,5	34,0	34,5	109	0,0	69,0
20,1	66	33,0	35,0				

Note! There always have to be a shim on the minimum side of the -110cc motor.
(9 mm) The -110cc motor will be damaged if set below angles of 6,5°.

Displacement limiter V14-160

Setting angle [degree]	Displacement [cm ³ /varv]	Shim maximum side [mm]	Shim minimum side [mm]	Setting angle [degree]	Displacement [cm ³ /varv]	Shim maximum side [mm]	Shim minimum side [mm]
6,5	31,6	69,5	0,0	20,1	96	39,5	30,0
6,6	32	69,0	0,0	20,3	97	39,0	30,5
6,8	33	68,5	0,5	20,5	98	38,5	31,0
7,0	34	68,0	1,0	20,8	99	38,0	31,5
7,2	35	67,5	1,5	21,0	100	37,5	32,0
7,4	36	67,5	2,0	21,2	101	37,0	32,5
7,6	37	67,0	2,5	21,4	104	36,5	33,0
7,8	38	66,5	3,0	21,6	103	36,0	33,5
8,0	39	66,0	3,0	21,9	104	35,5	34,0
8,2	40	65,5	3,5	22,1	105	35,0	34,5
8,4	41	65,0	4,0	22,3	106	34,5	35,0
8,7	42	64,5	4,5	22,5	107	34,0	35,5
8,9	43	64,0	5,0	22,8	108	33,0	36,0
9,1	44	64,0	5,5	23,0	109	32,5	36,5
9,3	45	63,5	6,0	23,2	110	32,0	37,0
9,5	46	63,0	6,5	23,4	111	31,5	37,5
9,7	47	62,5	6,5	23,6	112	31,0	38,0
9,9	48	62,0	7,0	23,9	113	30,5	39,0
10,1	49	61,5	7,5	24,1	114	30,0	39,5
10,3	50	61,0	8,0	24,3	115	29,5	40,0
10,5	51	60,5	8,5	24,5	116	29,0	40,5
10,7	52	60,0	9,0	24,8	117	28,0	41,0
10,9	53	60,0	9,5	25,0	118	27,5	41,5
11,2	54	59,5	10,0	25,2	119	27,0	42,0
11,4	55	59,0	10,0	25,5	120	26,5	42,5
11,6	56	58,5	11,0	25,7	121	26,0	43,5
11,8	57	58,0	11,0	25,9	122	25,5	44,0
12,0	58	57,5	11,5	26,1	123	25,0	44,5
12,2	59	57,0	12,0	26,4	124	24,0	45,0
12,4	60	56,5	12,5	26,6	125	23,5	45,5
12,6	61	56,0	13,0	26,8	126	23,0	46,0
12,8	62	56,0	13,5	27,1	127	22,5	47,0
13,0	63	55,5	14,0	27,3	128	22,0	47,5
13,3	64	55,0	14,5	27,5	129	21,0	48,0
13,5	65	54,5	15,0	27,7	130	20,5	48,5
13,7	66	54,0	15,5	28,0	131	20,0	49,5
13,9	67	53,5	15,0	28,2	132	19,5	50,0
14,1	68	53,0	16,0	28,4	133	18,5	50,5
14,3	69	52,5	16,5	28,7	134	18,0	51,0
14,5	70	52,0	17,0	28,9	135	17,5	52,0
14,7	71	51,5	17,5	29,1	136	17,0	52,5
14,9	72	51,0	18,0	29,4	137	16,0	53,0
15,2	73	50,5	18,5	29,6	138	15,5	53,5
15,4	74	50,0	19,0	29,9	139	15,0	54,5
15,6	75	49,5	19,5	30,1	140	14,0	55,0
15,8	76	49,0	20,0	30,3	141	13,5	55,5
16,0	77	49,0	20,5	30,6	142	13,0	56,5
16,2	78	48,5	21,0	30,8	143	12,0	57,0
16,4	79	48,0	21,5	31,0	144	11,5	57,5
16,6	80	47,5	22,0	31,3	145	11,0	58,5
16,9	81	47,0	22,5	31,5	146	10,0	59,0
17,1	82	46,5	23,0	31,8	147	9,5	59,5
17,3	83	46,0	23,5	32,0	148	9,0	60,5
17,5	84	45,5	24,0	32,3	149	8,0	61,0
17,7	85	45,0	24,5	32,5	150	7,5	62,0
17,9	86	44,5	25,0	32,7	151	7,0	62,5
18,2	87	44,0	25,5	33,0	152	6,0	63,0
18,4	88	43,5	26,0	33,2	153	5,5	64,0
18,6	89	43,0	26,0	33,5	154	4,5	64,5
18,8	90	42,5	26,5	33,7	155	4,0	65,5
19,0	91	42,0	27,0	34,0	156	3,0	66,0
19,2	92	41,5	27,5	34,2	157	2,5	67,0
19,5	93	41,0	28,0	34,5	158	1,5	67,5
19,7	94	40,5	28,5	34,7	159	1,0	68,5
19,9	95	40,0	29,0	35,0	160	0,0	69,0

Ordering Code

Example: **V14 - 110 - SVS - EP I 1 A - P 350 - N - 00 - 110 / 032 - 210 - 000**
 1 2 3 4 5 6 7 8 9 10 11 12 13 14 15 16

1. Frame size

- 110** – 110 cm³/rev
- 160** – 160 cm³/rev

2. Mounting flange

- C** – Cartridge (Cartridge version only - 110)
- I** – ISO (ISO 3019/2)
- Z** – ZF (ISO 3019/2)
- S** – SAE (SAE J744c)

3. Shaft seal

- V** – FPM (fluorocarbon)

4. Shaft end

- C** – DIN (ISO version)
- D** – DIN (ISO version)
- S** – SAE (SAE version)

5. Control

- AC** – Pressure compensator
- AH** – Pressure compensator with hydraulic override
- EO** – Electrohydraulic, two position
- EP** – Electrohydraulic, proportional
- HO** – Hydraulic, two-position
- HP** – Hydraulic, proportional

6. Control signal

- E** – External pressure (HO, HP)
- H** – 24 VDC (EO, EP)
- L** – 12 VDC (EO, EP)
- I** – Internal pressure (AC, AH)
- C** – Pressure cut off (HP, EP)

7. Control restrictor set

- 1** – 0,7
- 2** – 0,8
- 3** – 1,0 (standard)
- 4** – 1,2
- 5** – HPC
- x** – special

8. Control modulating pressure/current

- N** – AC: 0 bar; EP: non-selectable current
- A** – 15 bar¹⁾ (AC, AH, HP)
- B** – 25 bar¹⁾ (AC, AH, HP)
- C** – 50 bar¹⁾ (AC, AH)
- D** – 80 bar¹⁾ (AC, AH)

9. Valve options

- N** – None
- B** – Brake valve and pressure relief valves
- L** – Flushing valve
- P** – Pressure relief valves
- W** – Load holding valve

10. Pressure relief valve opening pressure [bar] or Flushing valve restrictor. See catalogue MSG30-8223/UK for further information.

- 000** – Without Pressure relief valves

11. Sensor options

- N** – None
- P** – Prepared for speed sensor

12. Factory issued number for special versions

13. Max displacement [cm³/rev]

14. Min displacement [cm³/rev]

15. Threshold setting

- AC:** select pressure between 100 and 350 [bar]
- EO, EP:** 12 VDC: 400 [mA]
24 VDC: 200 [mA]
- HO, HP:** Factory set at 10 [bar]
Is adjustable between 5 – 25 [bar]

16. Setting for pressure cut off (HPC, EPC control)

- HPC, EPC:** Select cut off pressure between 75 – 400 [bar]

¹⁾Valid at max utilized displacement range

Motor installation

Direction of rotation

The V14 motor is bi-directional. Fig. 1 shows shaft rotation vs. direction of flow.

When the A port is pressurized (black arrow) the motor turns counter clockwise (left hand, L, rotation), and when the B port is pressurized (open arrow) the shaft turns clockwise (right hand, R, rotation).

Note: Before installing the V14 in series (when the A and B ports can be subject to high pressures simultaneously) contact Parker Hannifin (Pump & Motor Div.).

Filtration

Maximum motor service life is obtained when the fluid cleanliness meets or exceeds ISO code 20/18/13 (ISO 4406).

A 10 µm (absolute) filter is recommended.

Case pressure

The lowest and highest recommended case pressure (V14 with shaft seal type V) at selected shaft speeds is shown in the table below.

The min case pressure secures sufficient lubrication, and the max case pressure, which secures nominal seal life, should be measured at the drain port.

Size		1500	3000	4000	5000	6000
V14-110	max	10	1-6	1.5-5	2-4.5	-
V14-160	max	10	1-6	2-5.5	2.5-5.5	-

Min and max case pressure [bar] vs. shaft speed [rpm].

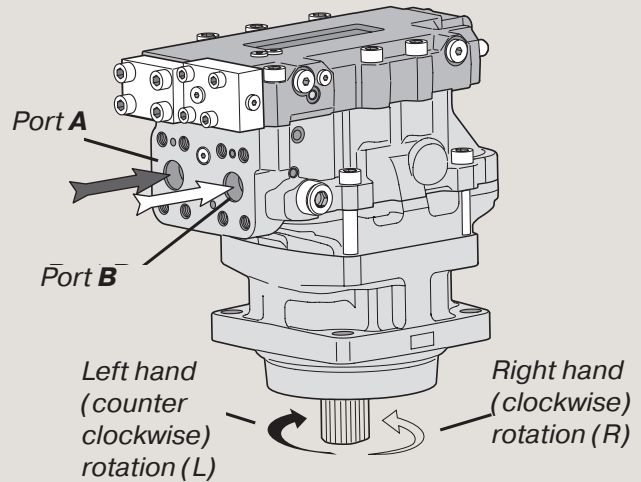

Fig. 1 (motor rotation vs. direction of flow).

Required inlet pressure

The motor operates as a pump under certain conditions. When this occurs, a minimum pressure must be maintained at the inlet port. Increased noise and gradually deteriorating performance due to cavitation may otherwise be experienced.

A 15 bar inlet pressure, measured at the motor inlet port, satisfies most operating conditions.

Contact Parker Hannifin (Pump & Motor Div.) for more specific information on inlet pressure requirements

Note: For high speed info, see Marketing information database

Operating temperatures

The following temperatures should not be exceeded, FPM shaft seal (type V) can be used to 115°C drain fluid temperature.

Continuous operation at high power levels usually requires case flushing in order for the fluid to stay above the minimum viscosity requirements.

A flushing valve and restricting nozzle, available as an option, provide the necessary main circuit flushing flow.

Refer to fig. 2 (next page).

Drain ports

There are two drain ports on the V14; the uppermost drain port should always be utilized (fig. 3).

In order to avoid excessively high case pressure, the drain line should be connected directly to the reservoir.

Note: When the motor is operating, the case must be filled with fluid to at least 50%.

Hydraulic fluids

Ratings and performance data for series V14 motors are valid when a good quality, contamination-free, petroleum-based fluid is used in the hydraulic system.

Hydraulic fluids type HLP (DIN 51524), automatic transmission fluids type A, or API CD engine oils can be used.

Fire resistant fluids, when used under modified operating conditions, and synthetic fluids are also suitable.

When the hydraulic system has reached full operating temperature, the motor drain oil viscosity should be above 8 mm²/s (cSt).

At start-up, the viscosity should not exceed 1500 mm²/s.

The ideal operating range for the V14 series is 15 to 30 mm²/s.

The following information (available from Parker Hannifin, Pump & Motor Div.) provide additional information about:

- Hydraulic fluid specifications
- Fire resistant fluids

Before start-up

Make sure the motor case as well as the entire hydraulic system is filled with hydraulic fluid. The internal leakage, especially at low operating pressures, is not sufficient to provide lubrication at start-up.

Note: A drain line spring loaded check valve (shown in fig. 2, 3 and 4) may have to be installed in order to prevent oil from being siphoned out of the motor case. This can otherwise happen e.g. if the reservoir is located below the utilized motor drain port.

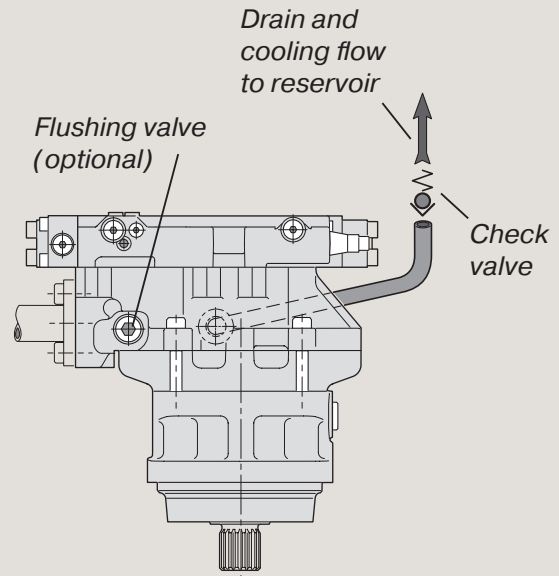

Fig. 2

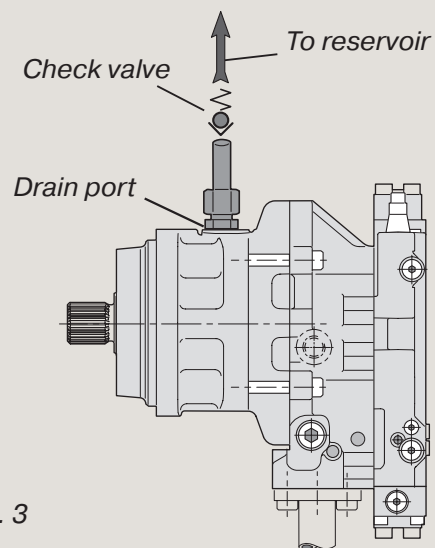

Fig. 3

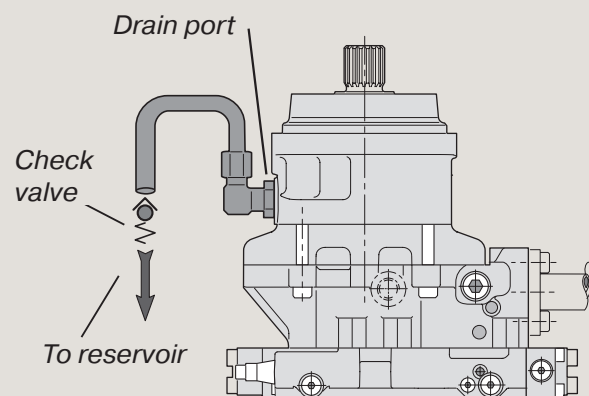

Fig. 4

Controls

The following controls satisfy most application requirements:

- AC (automatic pressure compensator)
- AH (automatic pressure compensator with hydraulic override)
- EO and HO (two position controls)
- EP and HP (proportional controls)

All controls utilize a servo piston that connects to the valve segment (refer to the illustration on page 4).

The built-in four-way servo valve determines the position of the servo piston and, in turn, the displacement.

The displacement angle (between output shaft and cylinder barrel) ranges from 35° (max) to 6.5° (min).

Servo supply pressure is obtained from the pressurized, main port through the corresponding, built-in shuttle valve.

The response time (i.e. from max-to-min or from min-to-max displacement) is determined by restrictors in the servo valve supply and return lines; refer to the schematics.

AC control description

- | | |
|---|--|
| <ol style="list-style-type: none"> 1. AC control cover 2. Servo valve spool 3. Modulating spring 4. Threshold spring 5. Feedback arm 6. Threshold adjustment screw 7. Seal nut 8*. Two-part threshold seal 9. End cover (max displ.) 10. Control module housing | <ol style="list-style-type: none"> 11. Max displ. limiting screw/bushing 12. Set screws 13. Connecting arm 14. Setting piston 15. Min displ. limiting screw/bushing 16. End cover (min displ.) E. Restrictor location, servo supply |
|---|--|

**Yellow seal cap is factory mounted. Red seal cap is available as spare part, part no. 3797065.*

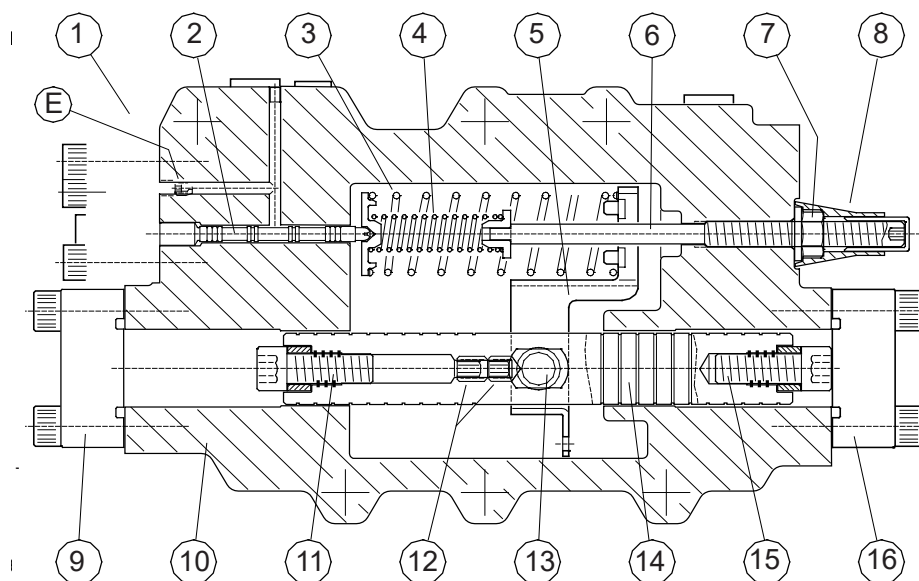

AC control module cross section (as seen from motor intermediate housing / control module interface).

AC control function

Refer to the illustration below left:

When pressure in port A (or B) increases, the servo valve spool is pushed to the right, directing flow to the right hand setting chamber - the setting spool moves to the left; displacement and output torque increases. At the same time, the shaft speed decreases correspondingly (at a constant pump flow to the motor).

Refer to the illustration below right:

When pressure in port A (or B) decreases, the servo valve spool moves to the left, directing flow to the left hand setting chamber - the setting spool moves to the right; displacement and output torque decreases.

At the same time, the shaft speed increases correspondingly (at a constant pump flow to the motor).

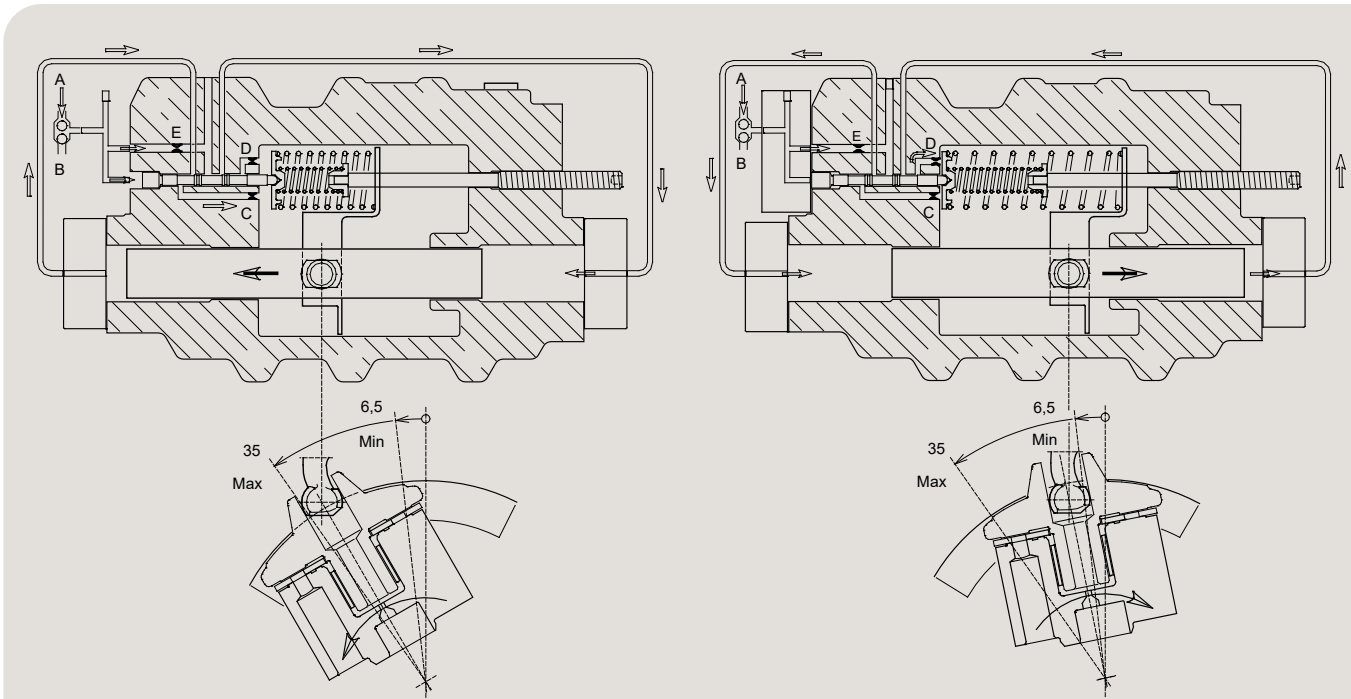

AC control function (displ. increase at increasing pressure).

AC control function (displ. decrease at decreasing pressure).

AC port and restrictor locations

Port connections and restrictor positions (AC control)

- A. Port A connection
- B. Port B connection
- C. Restrictor position, min-to-max servo pressure (M5)
- D. Restrictor location, max-to-min servo pressure (M5)
- E. Restrictor location, servo supply (refer to cross section page 10)

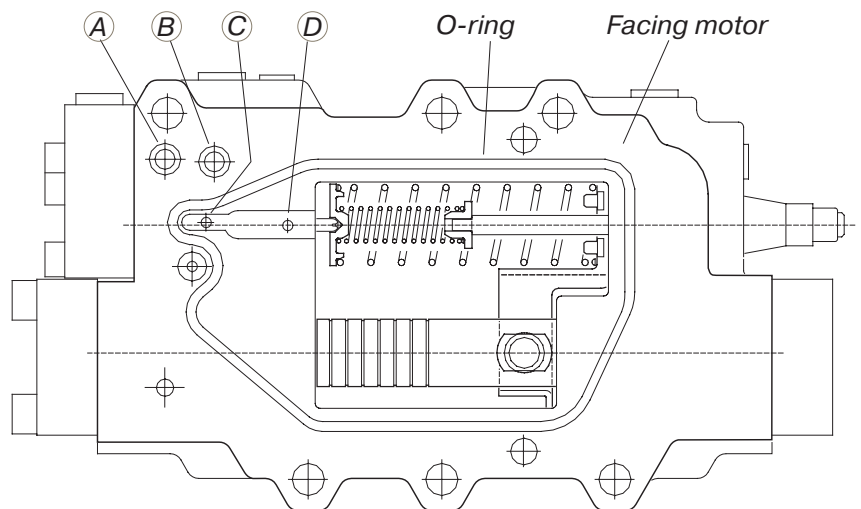

Gauge ports AC/AH control

Pressure setting procedure

The pressure setting procedure is valid for all pressure compensators (AC and AH).

WARNING

In order to prevent injury to the technician or the bystanders during the adjustment procedure, all hydraulic functions on the vehicle/machine should be disabled (e.g. wheels raised off the ground, work functions disconnected).

Avoid fast forward/reversed changes that can damage the synchronizing shaft.

1. Make sure that the motor has been supplied with the correct modulating spring (ordering code and name plate information should correspond).
2. Install 0 – 600 bar (0 – 8500 psi) gauges in port X1 and X5; refer to fig. 1.
3. Turn the adjustment screw counterclockwise to ensure that the threshold spring is unloaded. The distance between nut and screw end is approximately 23 mm when the threshold spring is unloaded.

Note: The distance between nut and screw end should not be more than 28 mm, because of risk for losing guiding of the spring.

4. Increase the system pressure (e.g. by blocking the motor shaft) to desired pressure setting (read the pressure in port X5).
5. Start to turn the threshold adjustment screw clockwise until the pressure in gauge X2 starts to increase. Right threshold pressure setting has been reached.

Note: One turn of the setting screw corresponds to 57 bar (820 psi)

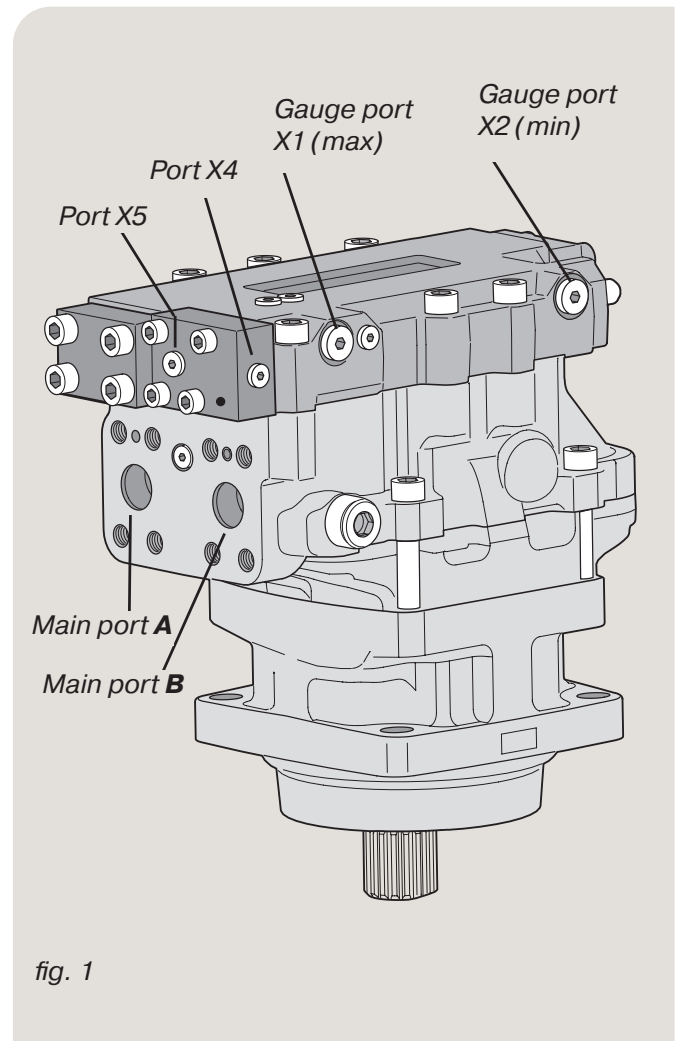

fig. 1

EO/EP/HO/HP control description

Basically, the controls function in a similar way. At increasing solenoid current (EP) or increasing pilot pressure (HP) the control moves towards the min displacement position. At decreasing current/pilot pressure, the control retracts towards max displacement.

In comparison with EP and HP, the EO and HO controls have no modulating spring or feedback arm; this means that only min and max displacements (but no intermediate positions) are available with these controls

Module cross section (EP shown)

- | | |
|--|---|
| 1*. Two-part seal | 11. Setting piston |
| 2. Control module housing | 12. Connecting arm |
| 3. Treshold adjustment screw | 13. Set screws |
| 4. Feedback arm (EP, HP only) | 14. Min displ. limiting screw/bushing |
| 5. Treshold spring | 15. Setting piston position sensor |
| 6. Modulating spring (EP, HP only) | 16. End cover position sensor(min displ. limit) |
| 7. Servo valve spool | E. Restrictor location, servo supply |
| 8. Solenoid (EO, EP only); cover on HO, HP | |
| 9. End cover (max displ. limit) | |
| 10. Max displ. limiting screw/bushing | |

**Yellow seal cap is factory mounted. Red sealcap is available as spare part, part no. 3797065.*

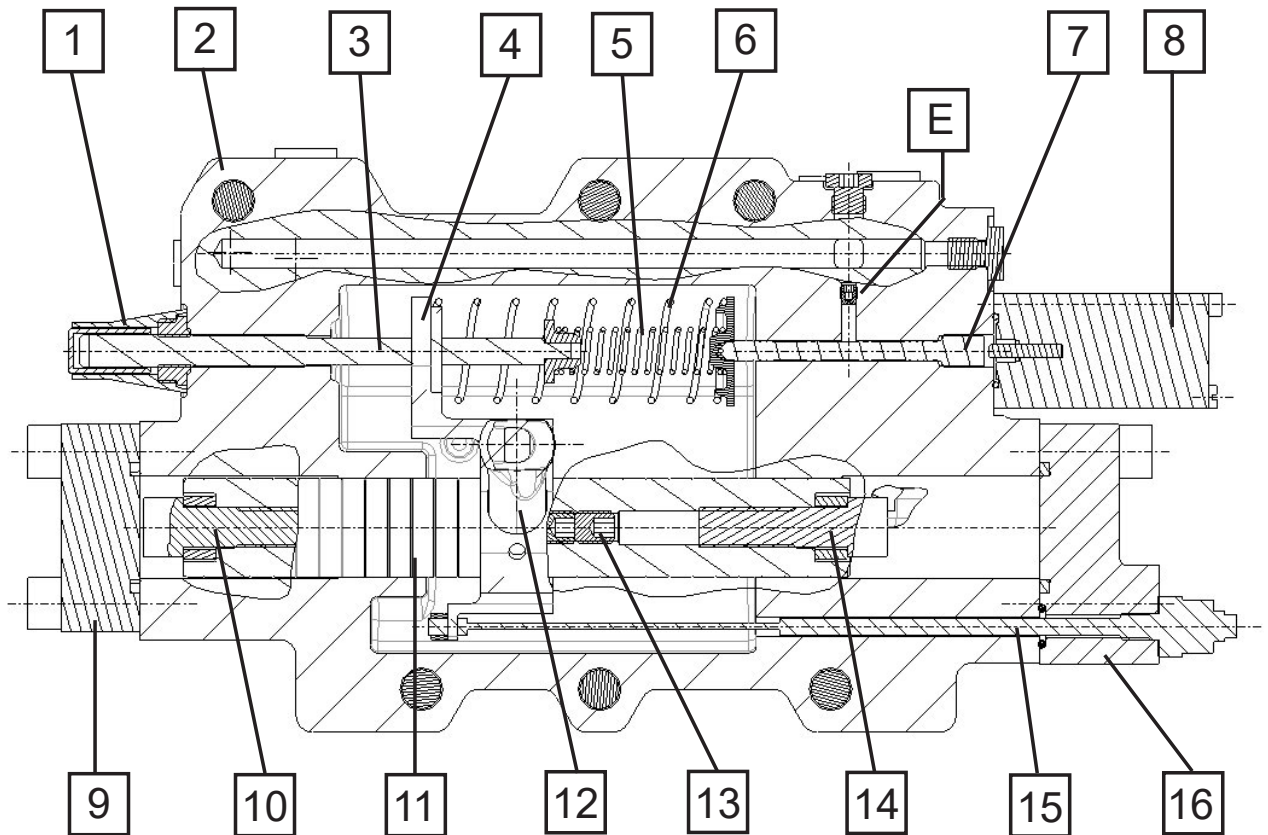

EP control function

(solenoid current increasing)

Refer to the illustration below left:

At an increasing current (above the threshold value), the solenoid spool pushes left on the servo valve spool, and flow is directed to the left hand setting chamber - the setting spool moves to the right and the displacement decreases.

This means, that the shaft speed increases while the output torque decreases correspondingly (at a constant pump flow and system pressure).

HP control function

(decreasing pilot pressure)

Refer to the illustration below right:

When the pilot pressure decreases, the pilot piston retracts, the servo valve spool moves to the right and flow is directed to the right hand setting chamber - the setting spool moves to the left and the displacement increases.

The shaft speed now decreases and the available output torque increases correspondingly (at a constant pump flow and system pressure).

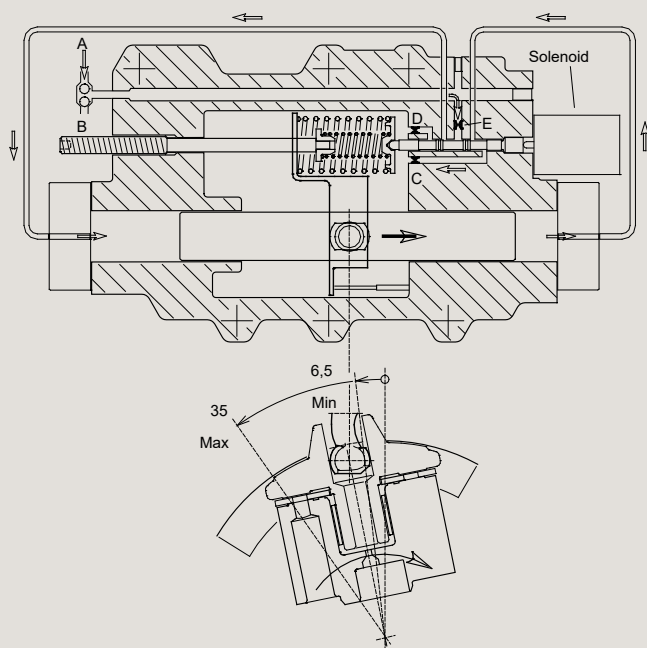

EP control function (displ. decrease at increasing current).

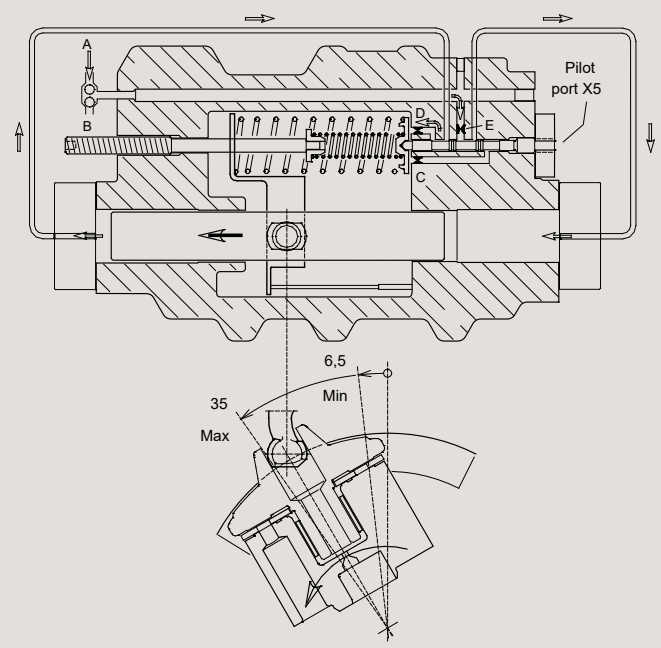

HP control function (displ. increase at decreasing pilot pressure).

EO/EP/HO/HP port and restrictor locations

Port connections and restrictor positions (EP control)

- A. Port A connection
- B. Port B connection
- C. Restrictor position, max-to-min servo pressure
- D. Restrictor position, min-to-max servo pressure
- E. Restrictor location, servo supply (refer to cross section page 13)

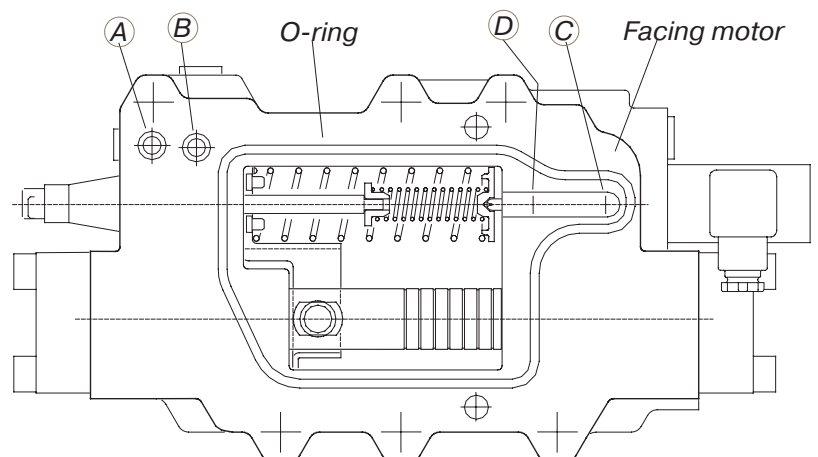

Gauge ports EO/EP/HO/HP

The pressure/current setting procedure is valid for all proportional and two-position controls (EO, EP, HO and HP).

WARNING

In order to prevent injury to the technician or the bystanders during the adjustment procedure, all hydraulic functions on the vehicle/machine should be disabled (e.g. wheels raised off the ground, work functions disconnected).

Avoid fast forward/reversed changes that can damage the synchronizing shaft.

1. Make sure that the motor has been supplied with the correct modulating spring (ordering code and nameplate information should agree). The hydraulic coil should be 50°C (120°F).
2. Install 0 – 600 bar (0 – 8500 psi) gauge in port X2. Use a 0 – 60 bar (0 – 850 psi) gauge to measure pilot pressure if it is a HO or HP.
3. Turn the adjustment screw counterclockwise to ensure that the threshold spring is unloaded. The distance between nut and screw end is approximately 22 mm when the threshold spring is unloaded.

Note: If you remove solenoid or end cover the maximum distance between nut and screw end should not be more than 16 mm. If the unit is assembled the maximum distance between nut and screw end should not be more than 22 mm.

HO or HP controls

4. Pressurize port X5 to desired threshold (the control goes to min displ.). Standard factory setting is 10 bar. Optional setting is 5 – 25 bar.

EO or EP controls

4. Apply the desired threshold current to the solenoid (the control goes to min displ.).

Standard factory setting is
 400 mA (12 VDC)
 200 mA (24 VDC)

5. Start to turn the threshold adjustment screw clockwise until the pressure in gauge X1 starts to increase. Right threshold pressure setting has been reached.

Note: One turn of the setting screw corresponds to:

- 40 mA on 12 VDC solenoids (EO, EP)
- 20 mA on 24 VDC solenoids (EO, EP)
- 2,1 bar (30 psi) on HO and HP controls

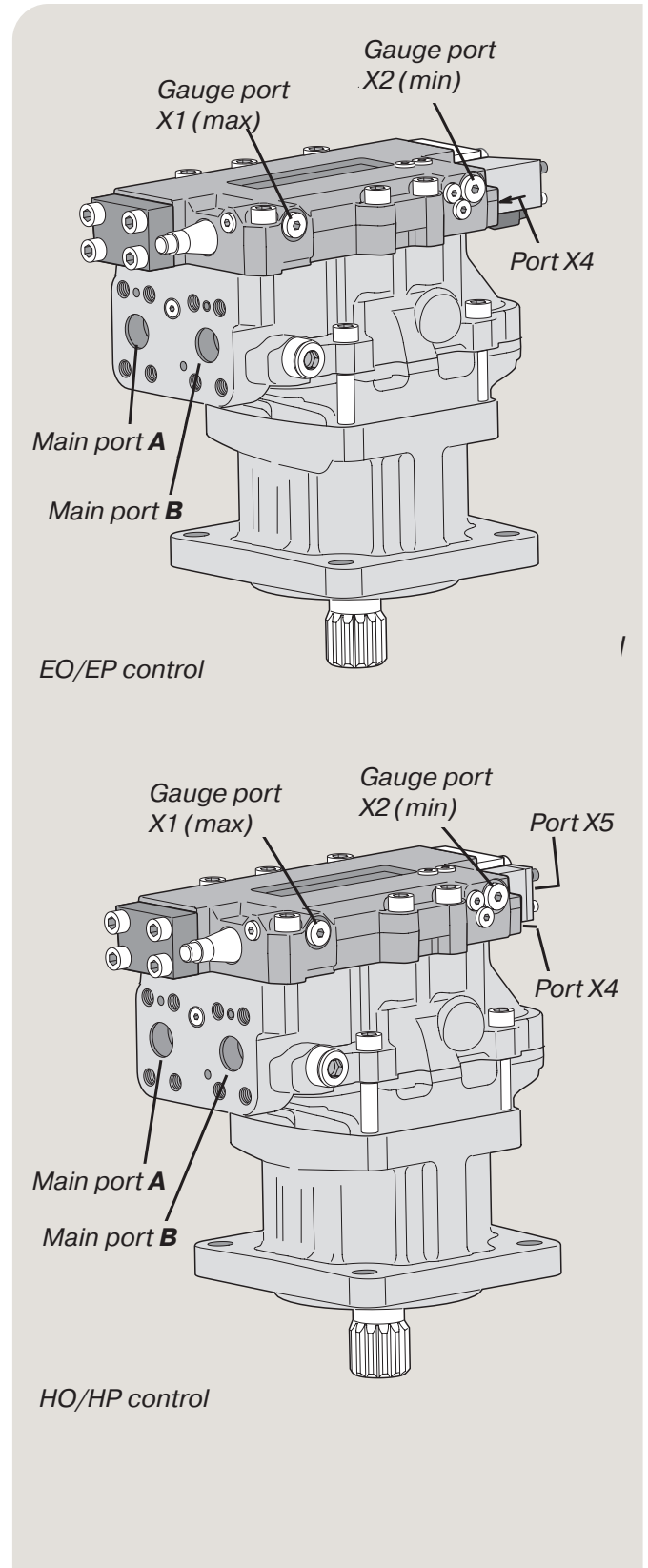

HPC/EPC, HP/EP control with pressure cut off

The pressure cut off overlays the HP control.

- If the system pressure increase, due to the load or reduced motor displacement, to the setting of the pressure cut off valve, the control increases displacement. When displacement increases, the available torque increases as well but the system pressure remains constant.
- Pressure cut off range is 100 – 400 bar (1450 – 5800 psi)
- Threshold pressure is preset from factory to 10 bar (145 psi) but is adjustable between 5 and 50 bar (70 – 700 psi).
- Threshold current is preset from factory to 400 mA (12V) or 200 mA (24V).
 12V is adjustable between 200-500 mA
 24V is adjustable between 100-250 mA

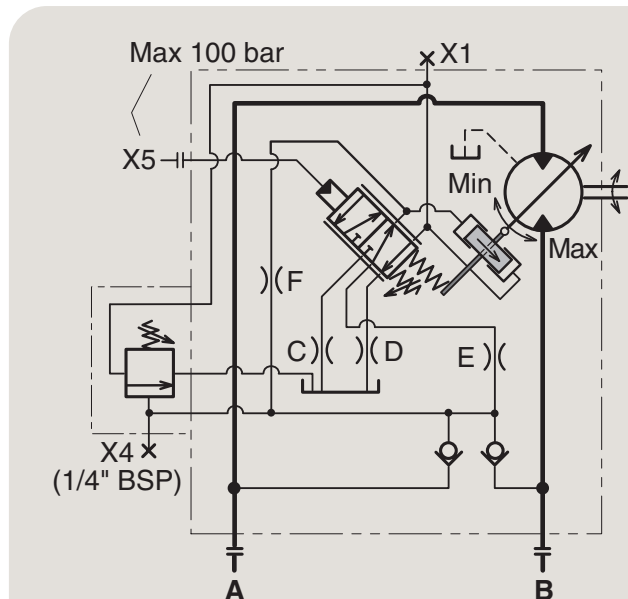

HPC schematic (shown: port X5 not pressurized; control moving towards max displacement).

Cut off pressure setting procedure:

Untie the locking nut. One turn of the setting screw corresponds to 48 bar. When desired pressure level is reached, tighten the locking nut.

1. Install 0 – 600 bar (0 – 8500 psi) gauges in port X1 and X4 and a 0 – 60 bar (0 – 850 psi) gauge in port X5.
2. Set the cut off pressure to minimum by turning the setting screw counter-clockwise until a distinct stop is reached.
3. Set the motor displacement to minimum by applying required pressure to port X5.
4. Increase the pressure in one of the main ports A/B (e.g. by blocking the motor shaft) to desired cut off pressure level.
5. Turn the setting screw clockwise, until the pressure in port X1 reaches the same pressure level as in X4. Desired cut off pressure has been reached.

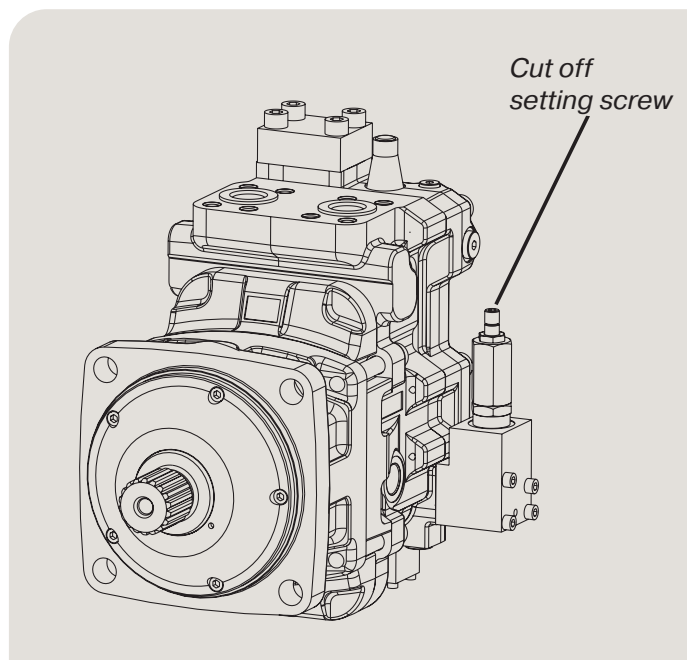

V14 Displacement limiter

Max and min displacement limiter consists of a socket head cap screw and a displacement spacer or spacers, see fig. 1. Suitable screw lengths for a particular max or min displacement range are shown in the table 1 below.

Displacement spacer (s) [mm]	Socket head cap screw
0 – 24	M12 x 45
25 – 39	M12 x 60
40 – 60	M12 x 80

Table 1

Displacement spacer changing procedure:

1. Disassemble the max or min end cover by loosen the four screws for the chosen cover.
2. Loosen the socket head cap screw from setting piston.
Note: This must be done when the control module is assembled on the motor, otherwise the feedback arm could be damaged.
3. Choose spacer (s) to obtain right displacement, see page 5 and 6, and place them on the socket head cap screw.
4. Tighten the socket head cap screw in the setting piston. The tightening torque have to be 105 ± 20 Nm.
5. Assembly the end cover. The tightening torque have to be 60 ± 10 Nm for the four screws.

low. What length the max or min displacement spacer should have to obtain a chosen displacement is shown on page 5 and 6. The displacement spacers are available in five different lengths: 1; 1,5; 2; 5 and 10 mm. To obtain the right displacement, the spacers can be combined with each other's. The thinnest spacer has to be mounted closest to the setting piston, and the others in increasing length order.

Formula for determining the setting angle (a) at a selected displacement D_a :

$$\sin a = (D_a / D_{35}) * \sin 35^\circ$$

where: D_{35} is max displacement at 35°

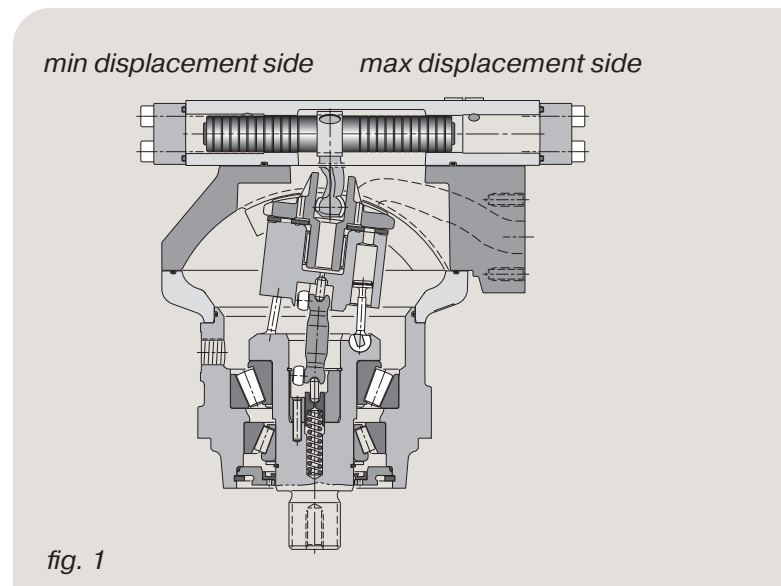
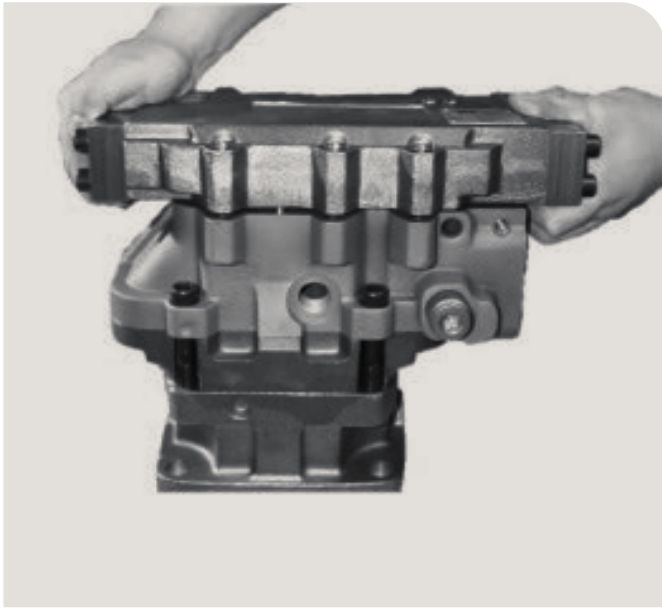

fig. 1

Disassembling



1. Remove the hexagon screws and lift the control module off.

Important! Lift the control module straight up so the two check valve balls don't fall down into the motor

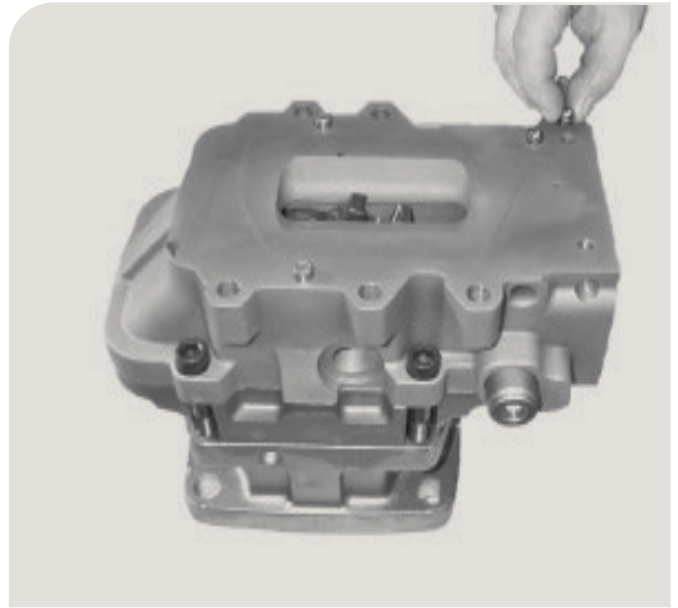

2. Remove the check valve balls.

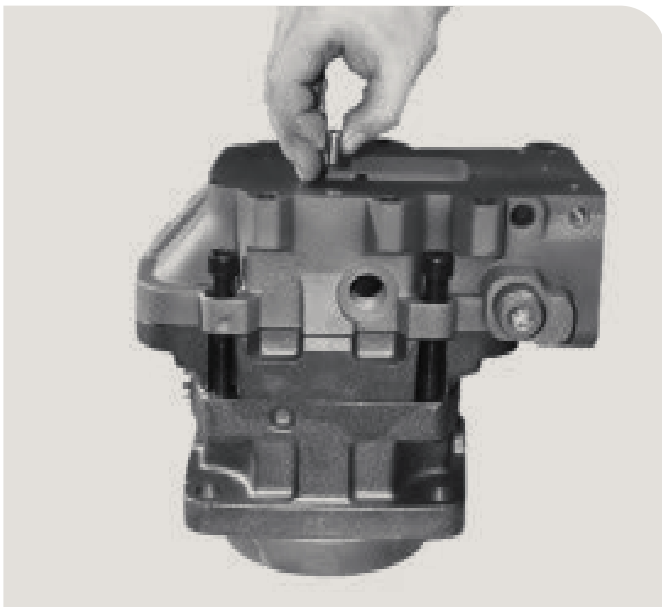

3. Be careful, the guide pins can be loose

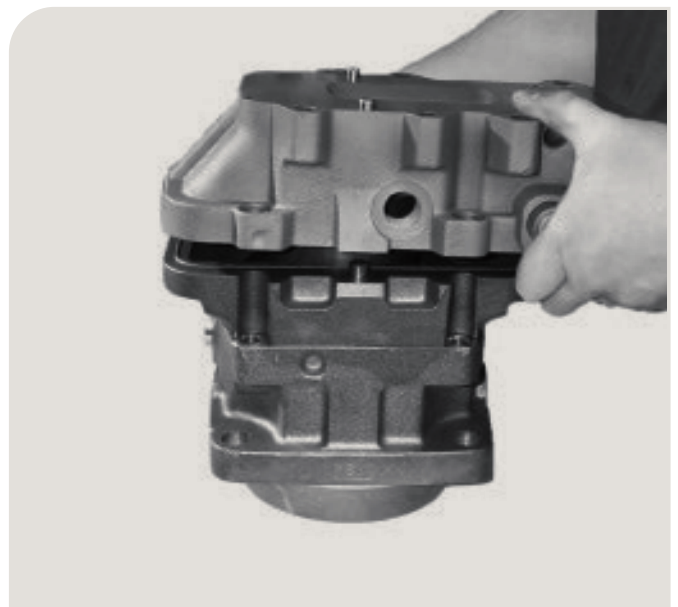

4. Remove the hexagon screws and lift the connection module.



5. Lift the valve segment.



6. Remove the cylinder barrel.

Note: The support pin assembled between cylinder barrel and joint shaft might fall down into the motor.



7. Remove the joint shaft. Make sure all joint rollers follow.



8. Remove the support pin assembled between joint shaft and guide pin.

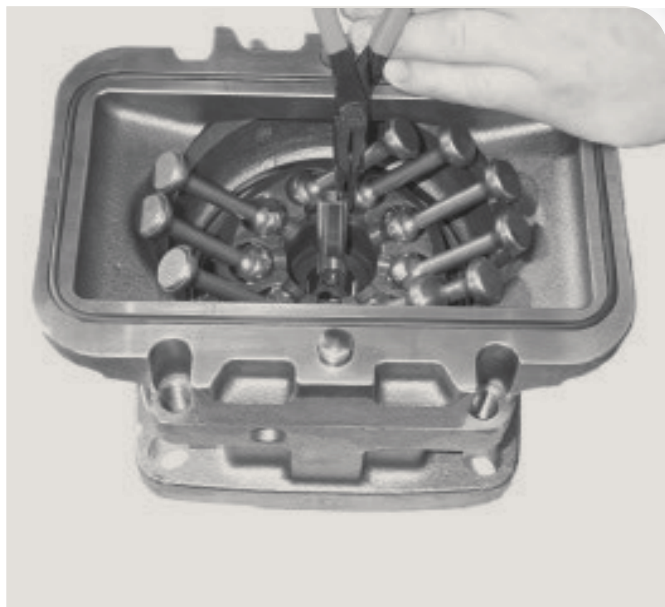

9. Remove the guide pin.

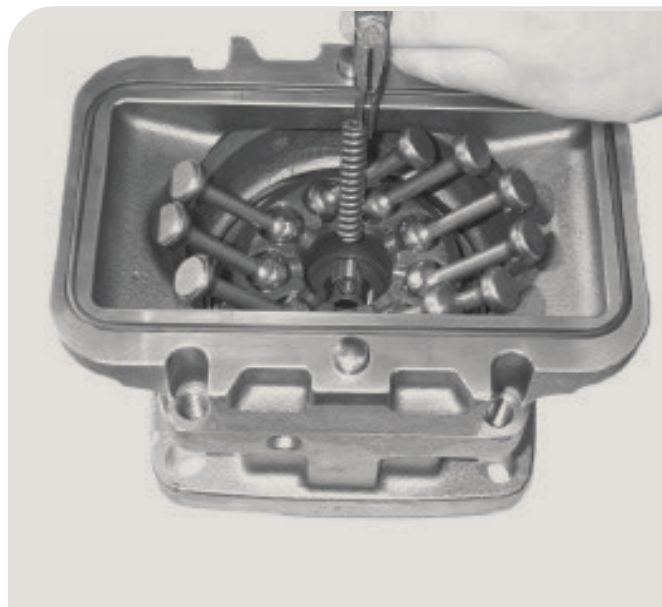

10. Remove the compression spring.



11. Remove the pistons and the O-ring fitted on the intermediate housing.

The pistons should be fitted in the same ball sockets as before if you don't exchange the pistons.



12. Remove the intermediate housing.

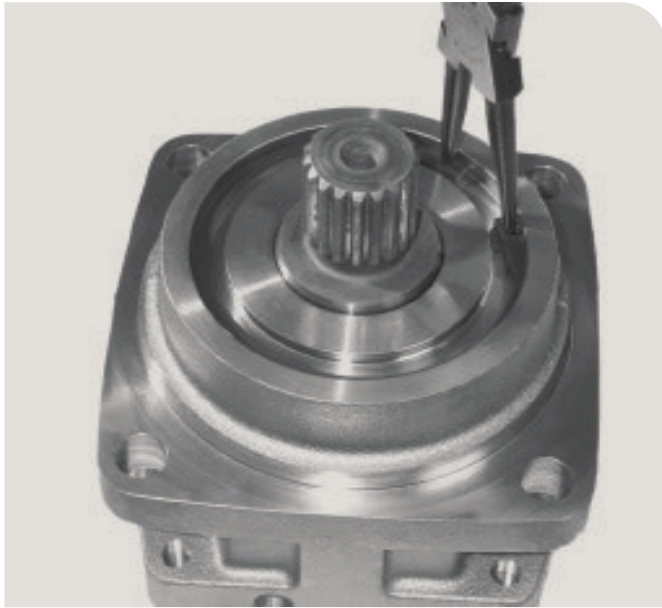

13. Remove the retaining ring.



14. Remove the seal carrier with shaft seal off. Change the shaft seal. Use the old shaft seal and press down the new shaft seal into the seal carrier.



15. Remove the O-ring.



16. Remove the retaining ring.

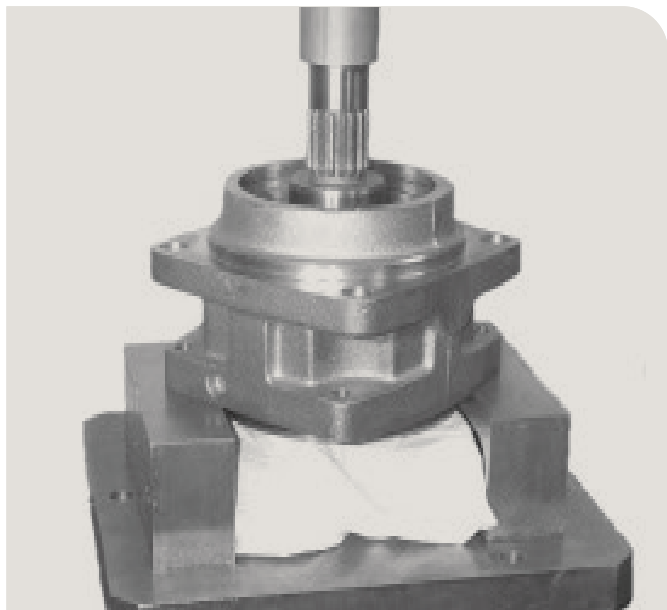

17. Use a hydraulic press to remove the shaft. Place something soft under the shaft to avoid damageing it.



18. Lift the bearing.

For disassembling the bearing on the shaft use a withdrawing tool.

Assembling

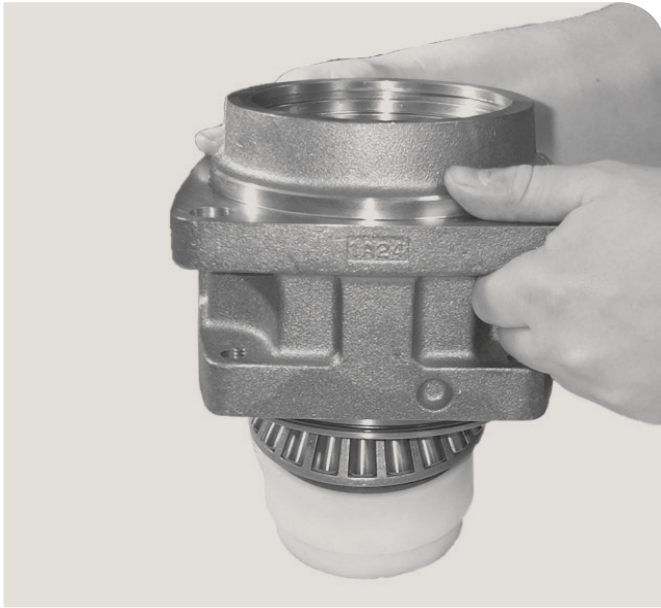

1. Install the bearing housing on the shaft.

Note: Place the shaft on a distance

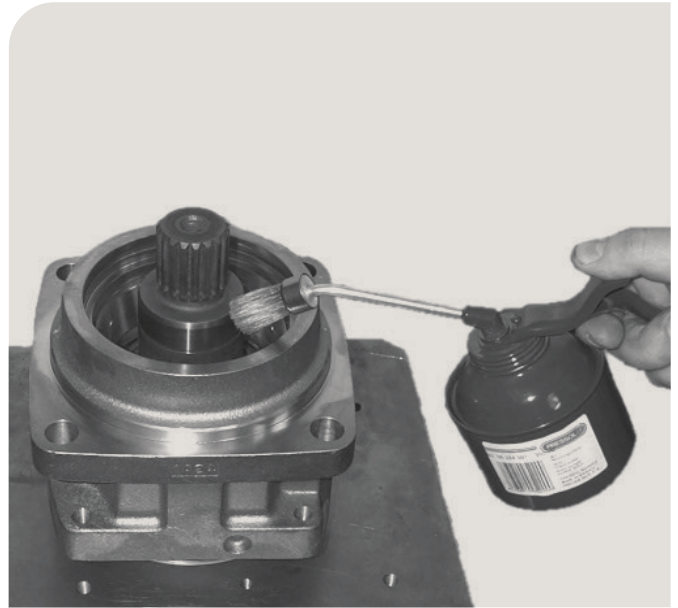

2. Lubricate the shaft with oil.

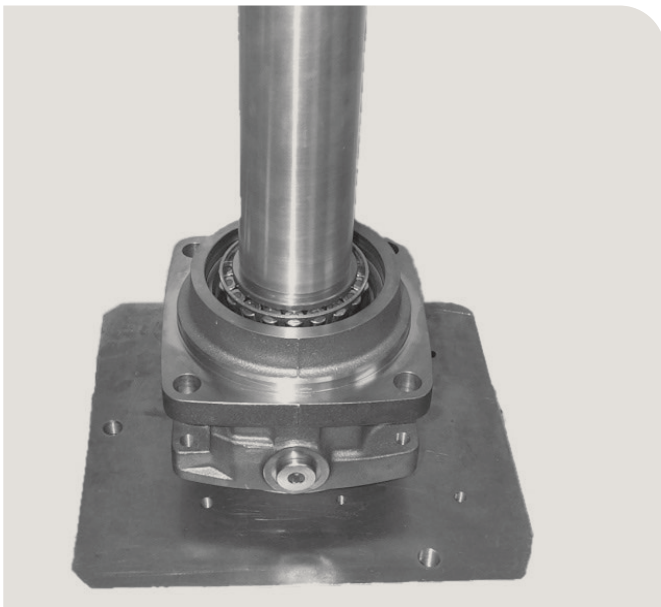

3. Place the bearing on the shaft and press it down.

Note: Be careful when you press so you achieve correct bearing setting, no backlash and a low rolling friction.



4. Assemble the spacer washer and the retaining ring.



5. Assemble the O-ring.

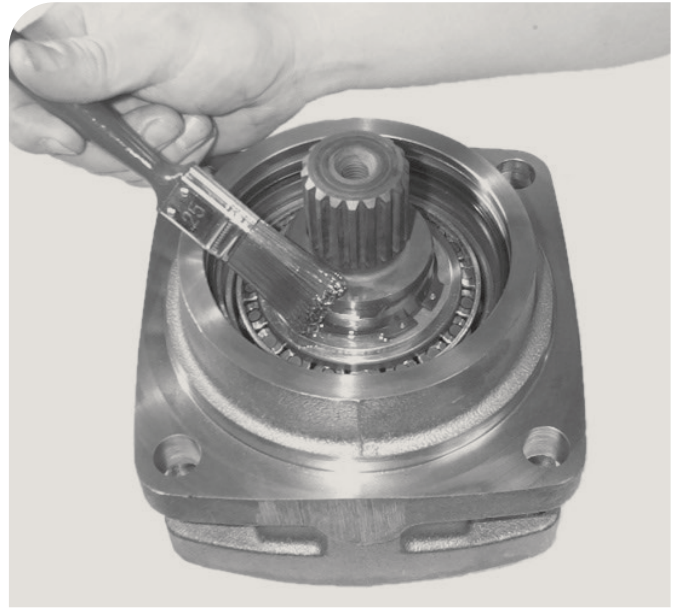

6. Lubricate the sealing surface with oil on the shaft.



7. Assemble the seal ring carrier with shaft seal.

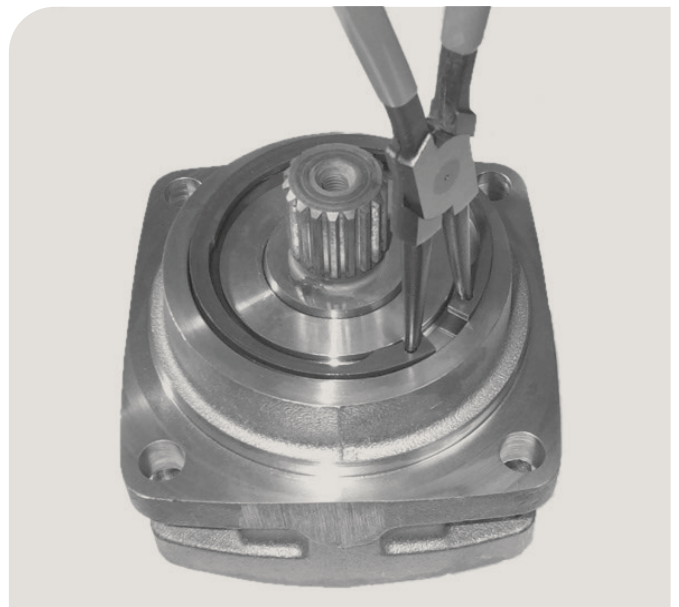

8. Assemble the retaining ring.



9. Assemble the compression spring.



10. Assemble the guide pin.

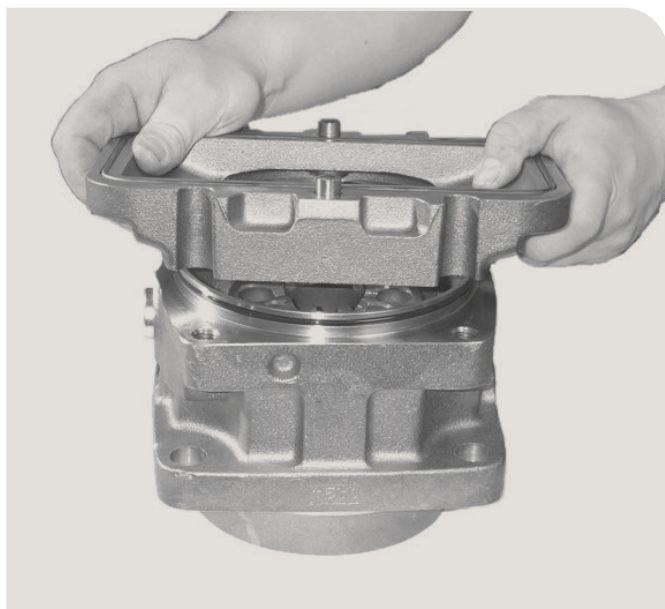

11. Assemble the intermediate housing with O-ring

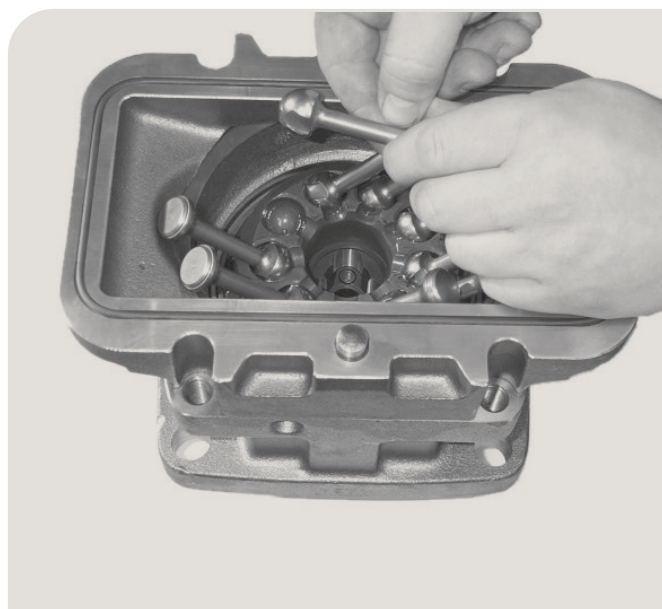

12. Assemble the pistons. If the pistons isn't exchanged, assemble them in the same ball sockets as before.

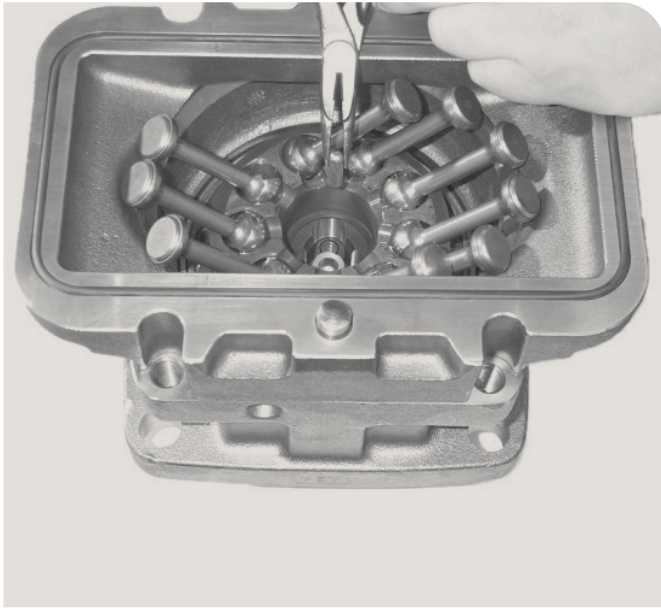

13. Assemble the lower support pin.



14. Assemble the joint shaft. Put some grease on the joint shaft so the rollers don't fall off.

Assemble the rollers with the chamfer inwards.



15. Assemble the upper support pin in the cylinder barrel. Put some grease on the pin so it don't fall down when assembling the cylinder barrel.

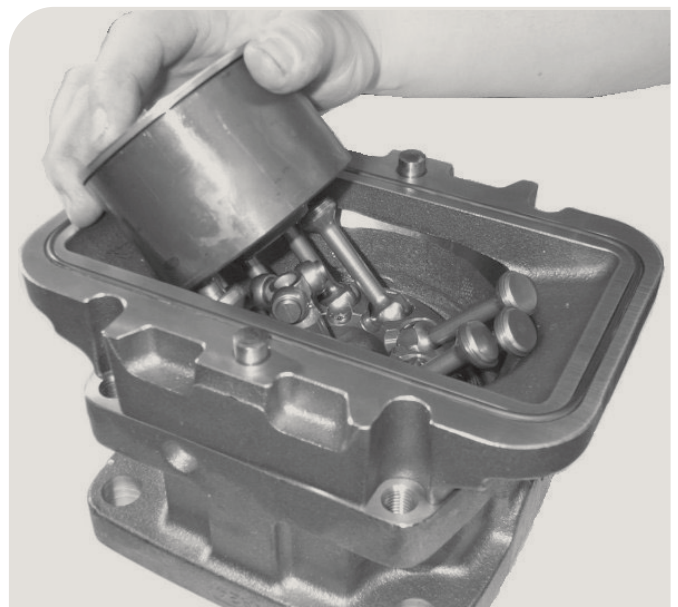

16. Assemble the cylinder barrel.

The sliding plate is assembled with the steel side towards the cylinder barrel and the bronze side towards the valve segment.



17. Make sure that the support pin is in the correct position by using a thin pin and feel that it is in correct position. The support pin shall stand up. It is very important.

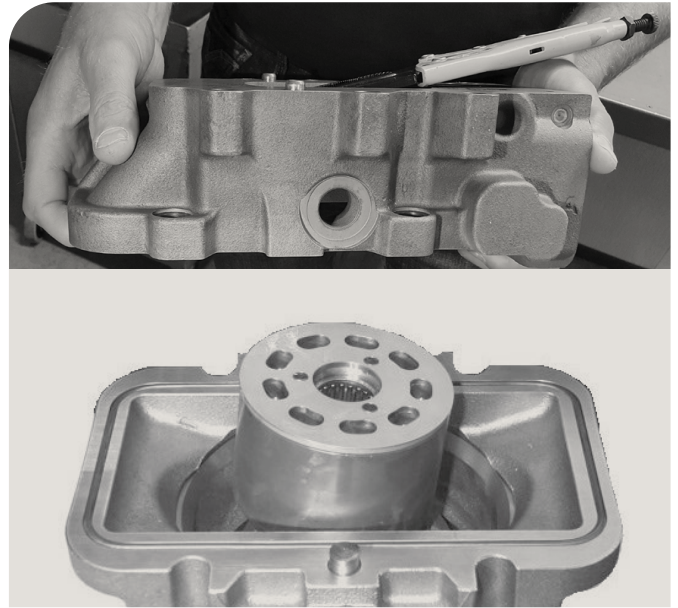

18. Assemble the connection module with the valve segment and the hexagon screws, 115 ± 10 Nm (110 cc) and 183 ± 10 Nm (160 cc). Use a welding plier to keep the valve segment in correct position.

Note: Be very careful, mind your finger.

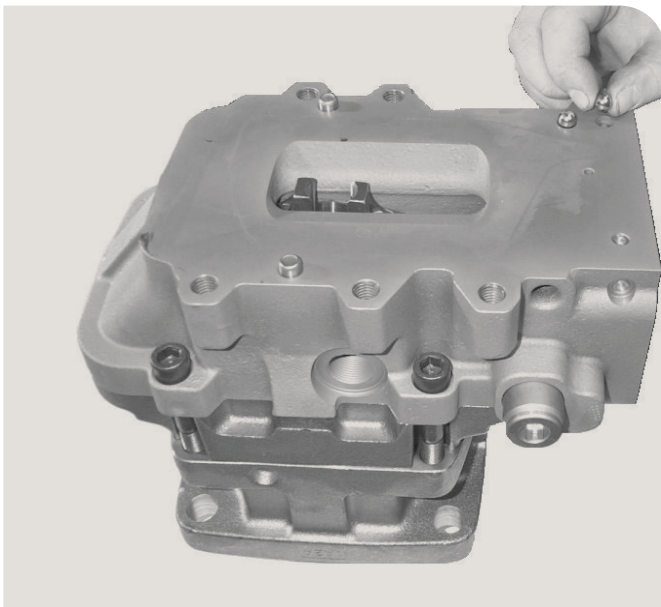

19. Assemble the check valve balls. Make sure that the guide pins are in place.

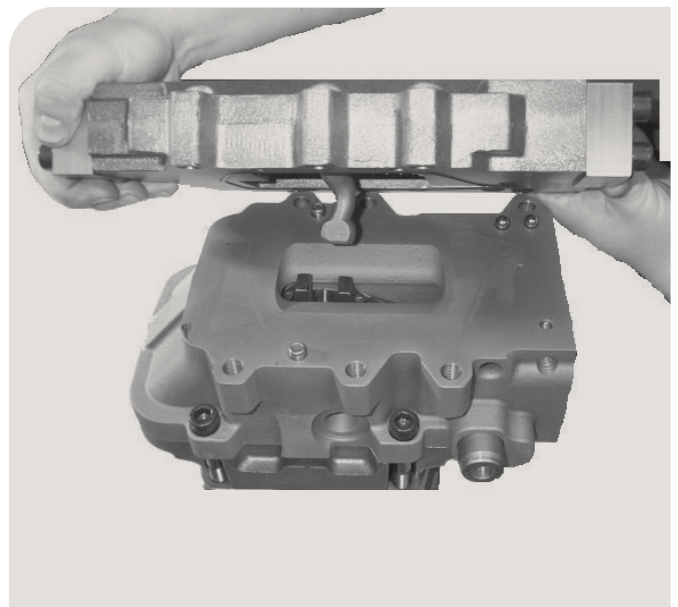

20. Assemble the control module, fit the setting piston arm into the valve segment. Tighten the hexagon screws, 115 ± 10 Nm.

● Change of Control Spring Kit and Filter (AC, AH)

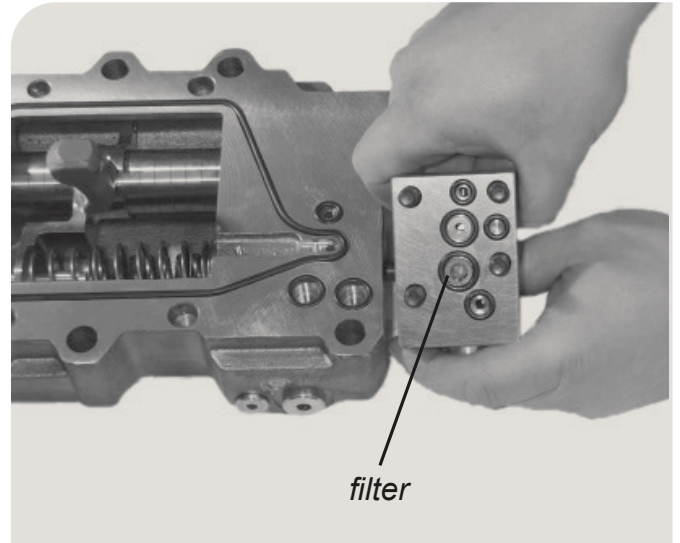
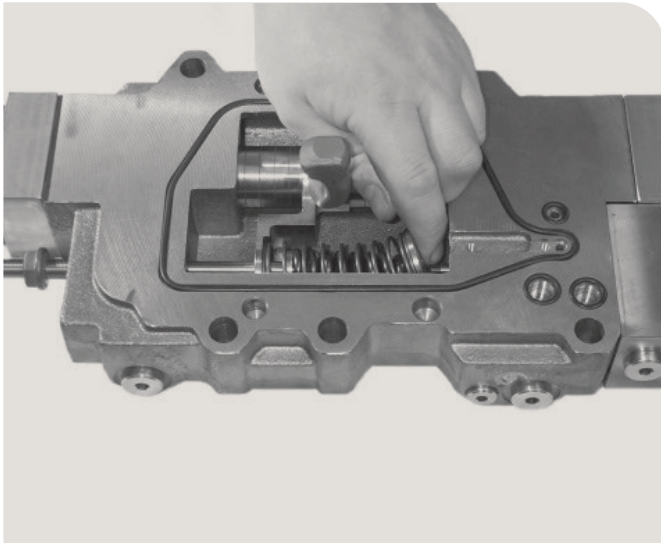

1. Turn the adjustment screw counter clockwise. Remove the spring kit.

Change the spring(s).

Put the new spring kit in position and turn the adjustment screw clockwise until the spring is preloaded.

2. If you need to change the filter remove it and place the new filter with the rounded/meash surface upwards (i.e. the same way as the oil flows).

When the filter has been disassembled it has to be changed.

● Splitview V14- 110/- 160

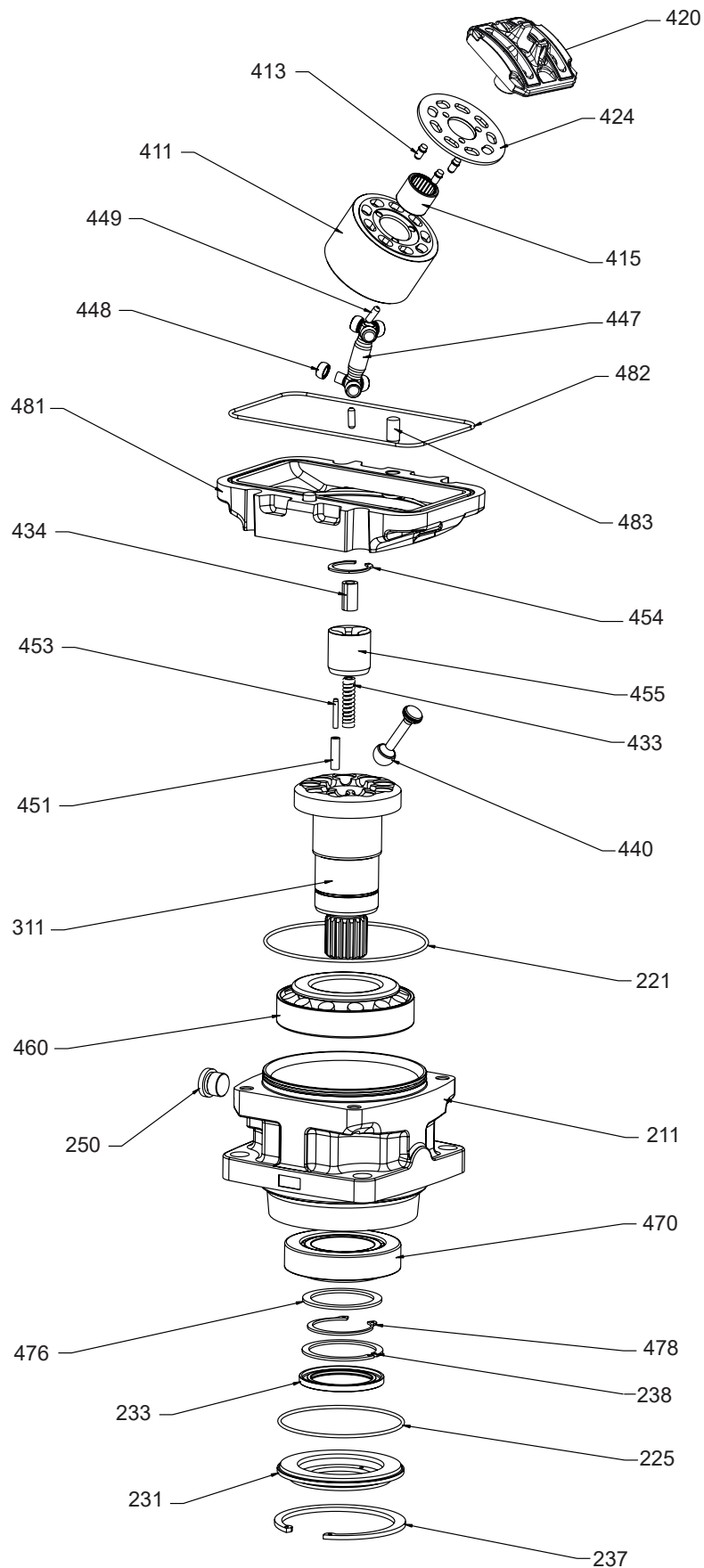

Spare parts V14- 110/- 160

Pos.	Description	Qty	Remarks
211	BEARING HOUSING	1	
221	O-RING 168*3/ O-RING 144.5*3	1	Seal Kit
225	O-RING 114.5*3	1	Seal Kit
227	O-RING 192*4	1	Seal Kit
231	SEAL CARRIER	1	
233	SHAFT SEAL 60*80*7	1	Seal Kit
237	RETAINING RING SGH120	1	Seal Kit
238	RETAINING RING SGH80	1	Seal Kit
250	HEX PLUG	1	ISO: 60± 10Nm; SAE: 110 ± 22Nm
311	SHAFT	1	Shaft Kit
411	CYLINDER BARREL	1	Cylinder Barrel Kit
413	GUIDE PIN	3	Sliding Plate Kit
415	NEEDLE BEARING	1	Cylinder Barrel Kit
420	VALVE SEGMENT	1	
424	SLIDING PLATE	1	Sliding Plate Kit
433	COMP SPRING	1	Shaft Kit
434	GUIDE PIN	1	Shaft Kit
440	PISTON ASSY	9	Piston Kit
447	JOINT SHAFT	1	Joint shaft Kit
448	JOINT ROLLER	6	Joint shaft Kit
449	SUPPORT PIN	2	Joint shaft Kit
451	SPRING PIN	3	Shaft Kit
453	PIN	3	Shaft Kit
454	RETAINING RING	1	Shaft Kit
455	JOINT COUPLING	1	Shaft Kit
460	TAP ROL BEARING	1	Bearing Kit
470	TAP ROL BEARING	1	Bearing Kit
476	SPACER WASHER	1	Bearing Kit
478	RETAINING RING	1	Bearing Kit
481	INTERMEDIATE HOUSING	1	
482	O-RING 197*3/ O-RING 220.0*3.0	1	Seal Kit
483	PIN	2	

Sliding Plate Kit

including Pos. 413 and 424

Part no.	Description	Qty
3723163	V14-110	1
3723164	V14-160	1

Piston Kit

including Pos. 440

Part no.	Description	Qty
3723161	V14-110	9
3723162	V14-160	9

Joint coupling kit

Including Pos. 433, 434, 451, 453,454 and 455

Part no.	Description	Qty
3724547	V14-110	1
3724546	V14-160	1

Joint shaft Kit

including Pos. 447, 448, 449

Part no.	Description	Qty
3723159	V14-110	1
3723160	V14-160	1

Cylinder Barrel Kit

including Pos. 411, 415

Part no.	Description	Qty
3793192	V14-110	1
3709756	V14-160	1

Bearing Kit

including Pos. 460, 470, 476, 478

Part no.	Description	Qty
3723975	V14-110	1
3723158	V14-160	1

Shaft Kit

including Pos. 311, 433, 434, 451, 453, 454, 455

Part no.	Description	Qty	Remarks
3723167	V14-110	1	Typ C
3723169	V14-160	1	Typ C
3723351	V14-110	1	Typ D
3724662	V14-160	1	Typ D
3723168	V14-110	1	Typ S
3723170	V14-160	1	Typ S

Seal kit V14-110/-160

including Pos. 221, 225, 227, 233, 237, 238, 482, 711, 712, 713, 732, 743, 744, 745, 748, 749, 751, 753, 754, 755, 756, 759, 791

Part no.	Description
3782299	V14-110/-160

Tightening Torque

Pos.	Nm
37, 716	105 ± 20
29	ISO 60 ± 10/ SAE110 ± 10
61	110 ± 10
133	ISO 60 ± 10/ SAE110 ± 10
520	ISO: 60± 10Nm; SAE: 110 ± 22Nm
250	ISO: 60± 10Nm; SAE: 110 ± 22Nm
493	V14-110 115±10, V14-160 183±10
701, 706, 707	1.2 ± 0.2
704	14 ± 4
705	26 ± 6
708, 723, 747	ISO 38 ± 8/ SAE 25 ± 5
722, 828	13 ± 3
733	60 ± 10
746	33 ± 6
791	22 ± 2
825	50 ± 10

Separate Items

Pos.	Part no.	Description	Qty	Remarks
420	3781307	V14-110	1	Valve segment
420	3782362	V14-160	1	Valve segment
211	On request	V14-110/ V14-160	1	Bearing housing
231	On request	V14-110/ V14-160	1	Seal carrier
481	On request	V14-110/ V14-160	1	Intermediate housing

Plug position

Pos.	Part no.	Description
115, 722, 828	VSTI10X1EDVITCF	M10
250, 520	VSTI22X1.5EDVITCF	M22
61	VSTI12X1EDVITCF	M12
708, 723, 747	VSTI14X1.5EDVITCF	M14
250, 520	12 HP5ON-S	1-1/16»
708, 723, 747	6 HP5ON-S	9/16»-18

**Splitview
 AC/AH Control**

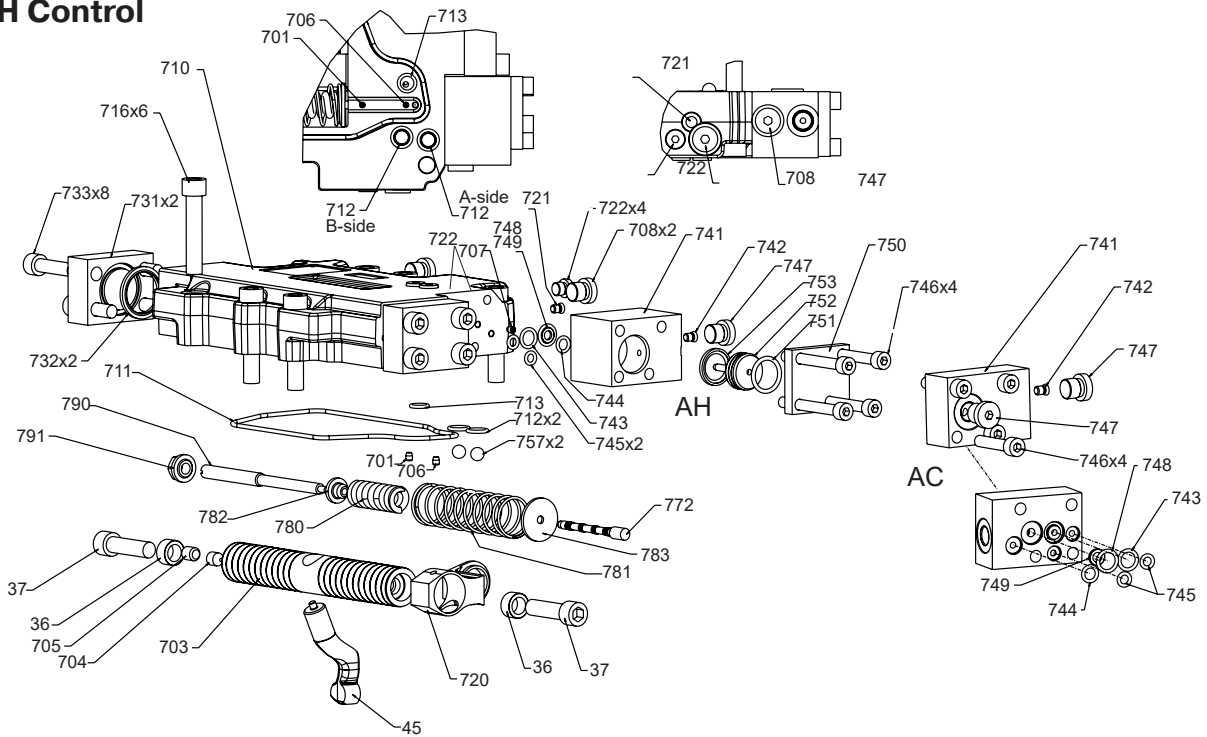

**Splitview
 HO/HP/HPC Control
 EO/EP/EPC Control**

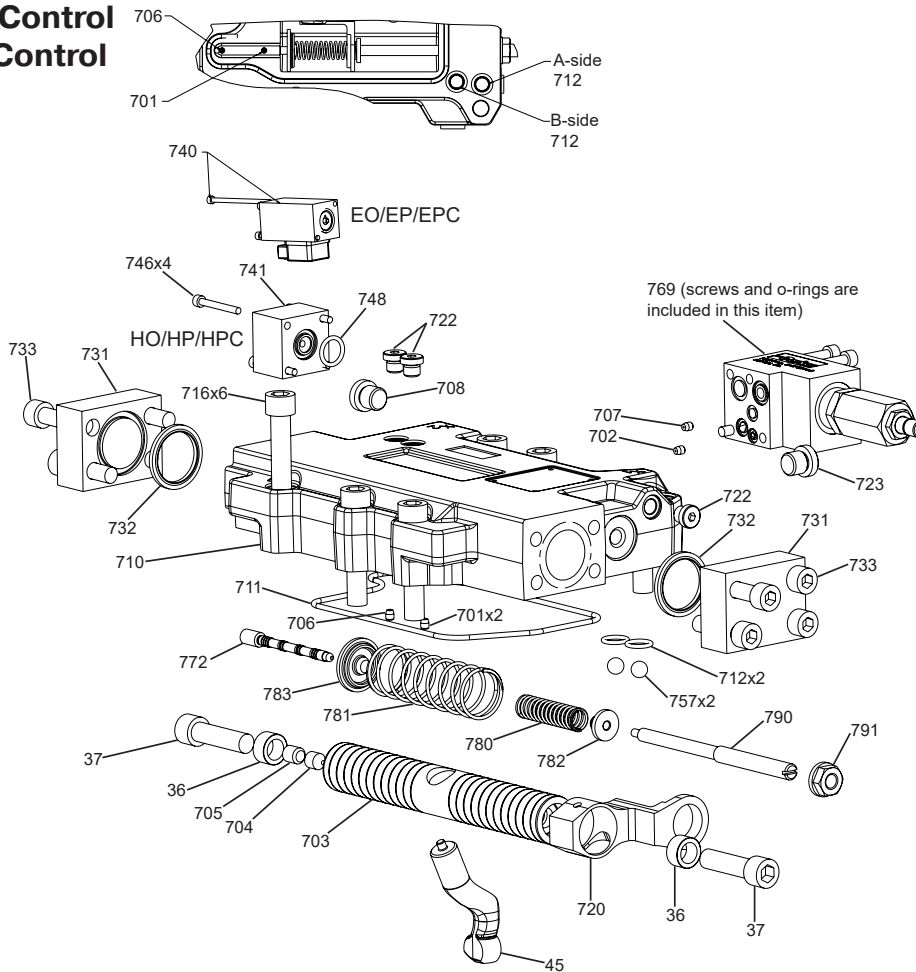

Spare parts AC/AH Control, EO/EP/EPC Control and HO/HP/HPC Control

Pos.	Description	Qty	Remarks
36	STOP WASHER	2	Stop washer Kit
37	HEX SKT SCREW	2	Stop washer Kit
45	CONNECTING ARM	1	Setting piston Kit AC/AH and EO/EP, HO/HP
701	NOZZLE	1	V14 Nozzle Kit M5*1
703	SETTING PISTON	1	Setting piston Kit AC/AH and EO/EP, HO/HP
704	SET SCREW	1	Setting piston Kit AC/AH and EO/EP, HO/HP
705	SET SCREW	1	Setting piston Kit AC/AH and EO/EP, HO/HP
706	NOZZLE	1	V14 Nozzle Kit M5*1
707	NOZZLE	1	V14 Nozzle Kit M5*1
708	HEX SKT PLUG	1	
710	CONTROL MODULE	1	
711	O-RING	1	Seal Kit
712	O-RING	2	Seal Kit
713	O-RING	1	Seal Kit
716	HEX SKT SCREW	6	
720	FEEDBACK ARM	1	Setting piston Kit AC/AH and EO/EP, HO/HP
721	SEAL PLUG	1	
722	HEX SKT PLUG	2 – 4	
731	COVER	2	Cover assy Kit Adjustable Displacement
732	FLANGE SEALING	2	Cover assy Kit Adjustable Displacement / Seal Kit
733	HEX SKT SCREW	8	Cover assy Kit Adjustable Displacement
740	SOLENOID	1	
741	HOUSING	1	AH control kit SAE
742	SEAL PLUG	1	
743	O-RING	1	AH control kit SAE / Seal Kit
744	O-RING	1	AH control kit SAE / Seal Kit
745	O-RING	2	AH control kit SAE / Seal Kit
746	HEX SKT SCREW	4	AH control kit SAE
747	HEX SKT PLUG	1	AH control kit SAE
748	O-RING	1	AH control kit SAE / Seal Kit
749	FILTER	1	AH control kit SAE / Seal Kit
750	AH COVER	1	AH control kit SAE
751	O-RING	1	AH control kit SAE / Seal Kit
752	AH CONTROL PISTON	1	Adjusting kit AC/AH and EO/EP AH control kit SAE
753	AH PISTON SEAL	1	AH control kit SAE / Seal Kit
754	O-RING 10.3*2.4	1	Seal Kit
755	O-RING 12.3*2.4	1	Seal Kit
756	O-RING 6.3*2.4	1	Seal Kit
757	BALL	1	Setting piston Kit AC/AH and EO/EP, HO/HP Adjusting kit AC/AH and EO/EP
759	SEAL WASHER M14	1	Seal Kit
772	VALVE SPOOL	1	Adjusting kit AC/AH and EO/EP
780	COMP SPRING	1	Adjusting kit AC/AH and EO/EP
781	COMP SPRING	1	Adjusting kit AC/AH and EO/EP
782	SPRING SEAT	1	Adjusting kit AC/AH and EO/EP
783	SPRING SEAT	1	Adjusting kit AC/AH and EO/EP
790	ADJUSTING SCREW	1	Adjusting kit AC/AH and EO/EP
791	SEAL NUT	1	Adjusting kit AC/AH and EO/EP / Seal Kit

Spare parts AC/AH Control; HO/HP/HPC Control and EO/EP/EPC Control

Control module can be ordered as complete assembly with factory settings Always use motor part number as reference.

Setting piston Kit – including Pos. 45, 703, 704, 705, 720, 757

Part no.	Description	Qty	Remarks
3723154	V14-110	1	AC/AH
3723155	V14-160	1	AC/AH
3723165	V14-110	1	EO/EP HO/HP
3723166	V14-160	1	EO/EP HO/HP

Stop washer Kit – including Pos. 36, 37

Part no.	Description	Qty	Remarks
3723153	V14-110/ V14-160	1	

Adjusting kit – including Pos. 752, 757, 772, 780, 781,782, 783, 790, 791

Part no.	Description	Qty	Remarks
3723176	V14-110/ V14-160	1	AC/AH
3723178	V14-110/ V14-160	1	EO/EP
3723177	V14-110/ V14-160	1	HO/HP

Cover assy Kit Adjustable Displacement – including Pos. 731, 732, 733, 734, 735

Part no.	Description	Qty	Remarks
3782700	V14-110/ V14-160	1	

Cover kit internal displacement – including Pos. 731, 732, 733

Part no.	Description	Qty	Remarks
3724251	V14-110/ V14-160	1	

V14 Nozzle Kit M5*1 – including Pos. 701, 706, 707

Part no.	Description	Qty	Remarks
3723156	V14-110/ V14-160	5 each diam.	

AH control kit SAE – including Pos. 741, 743, 744, 745, 746,747, 748, 749, 750, 751, 752, 753

Part no.	Description	Qty	Remarks
3723175	V14-110/ V14-160	1	AH

HO/HP control kit SAE – including Pos. 741, 746,748,

Part no.	Description	Qty	Remarks
3724252	V14-110/ V14-160	1	

Solenoid – including Pos. 740

Part no.	Description	Qty	Remarks
3784164	Solenoid	1	12V
3784163	Solenoid	1	24V
3787488	Connector	1	Deutsch DT06-2 Female

Splitview A-module

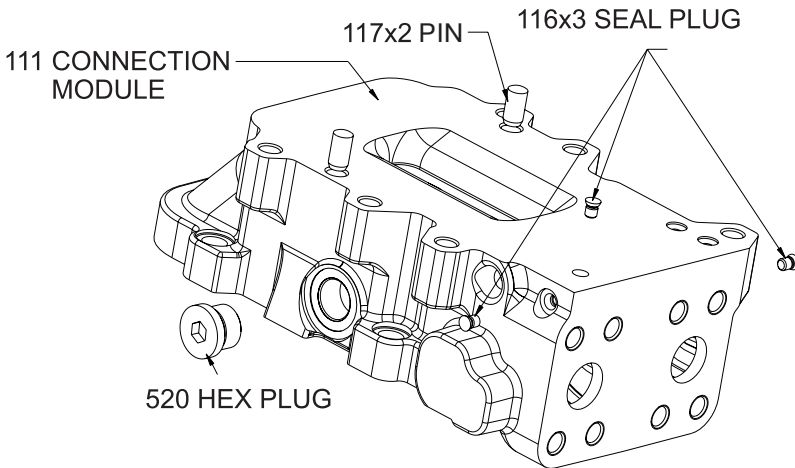

Connection Type N Pos: 111, 116, 117, 520		
	V14-110	V14-160
ISO	On request	3723171
SAE	3723173	3723340

Connection Type L Pos: 111, 116, 117, 520		
	V14-110	V14-160
ISO	3723174	3723172
SAE	On request	On request

Flushing valve kit Pos: 822, 823, 824, 825, 828, 835*	
	V14-110/-160
	3723157

* Nozzle diam (mm) 1.3, 1.5, 1.7, 2.0, 2.5, 3.0)

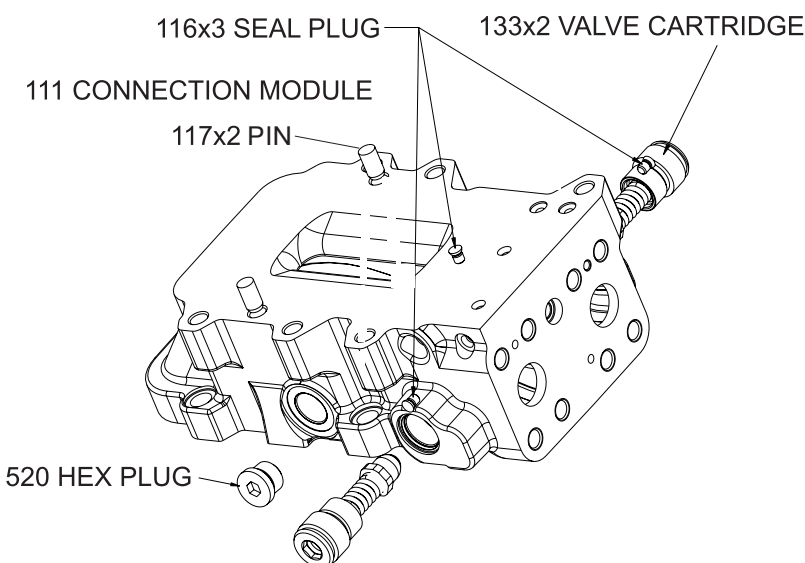
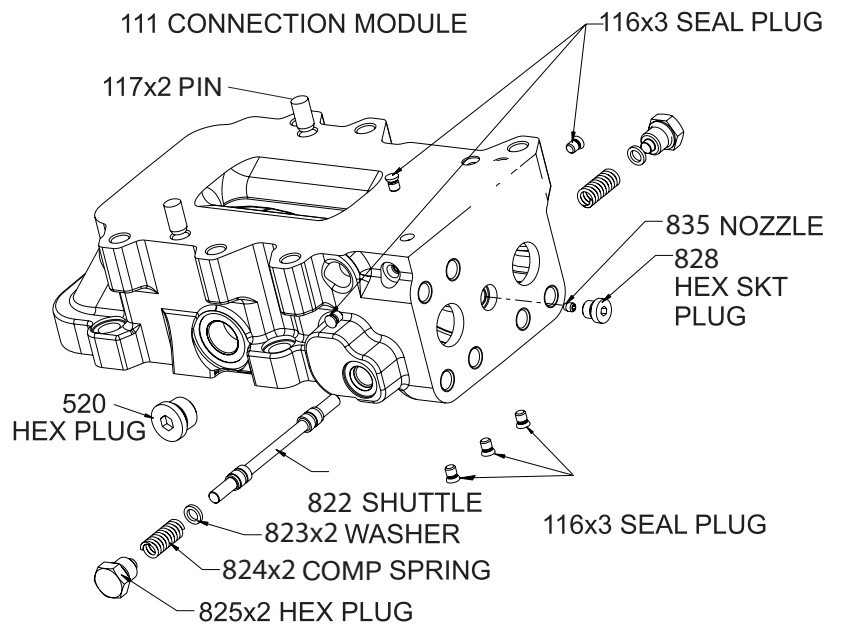

Connection Type P Pos: 111, 116, 117, 520		
	V14-110	V14-160
ISO	On request	On request
SAE	On request	On request

Valve Cartridge	Part no.
P300	9120029264
P330	9120029265
P350	9120029266
P380	9120029267
P400	9120029268
P420	9120029269
P450	3766886

Test procedure

Use a test stand that supplies a flow of about 30 l/min. and pressures of up to 300 bar. A secondary flow of 3 – 5 l/min. at a pressure of 25 bar is required to supply low pressure for externally supplied controls. EP control requires an amplifier supplying correct current according to specification.

Test

1. Fill housing with hydraulic fluid and start the pump in the test stand.
2. Increase the pressure with the restrictor valve on the return line. Max allowed pressure is 150 bar / 2150 psi.
3. Check the drain flow and compare with the table.

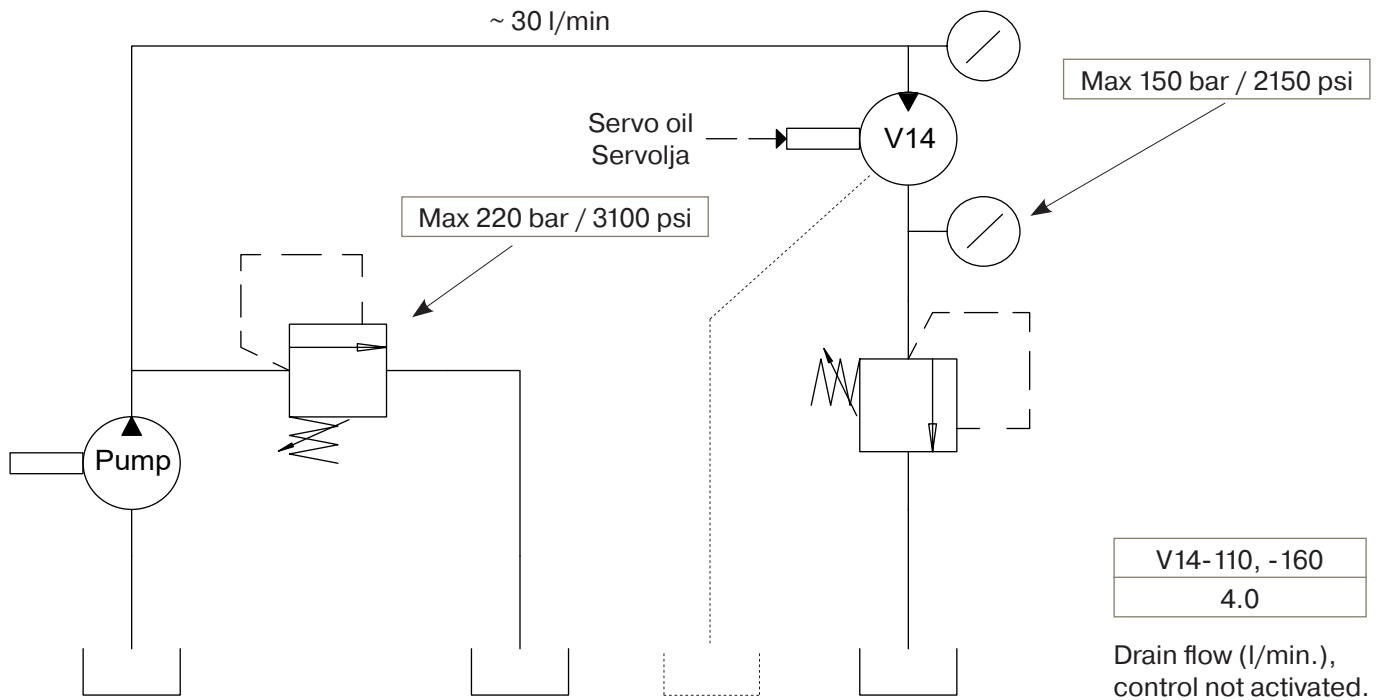

Position notification regarding Machinery Directive 2006/42/EC:

Products made by the Pump & Motor Division Europe (PMDE) of Parker Hannifin are excluded from the scope of the machinery directive following the "Cetop" Position Paper on the implementation of the Machinery Directive 2006/42/EC in the Fluid Power Industry.

All PMDE products are designed and manufactured considering the basic as well as the proven safety principles according to:

- ISO 13849-1:2015
- SS-EN ISO 4413:2010

so that the machines in which the products are incorporated meet the essential health and safety requirements.

Confirmations for components to be proven component, e. g. for validation of hydraulic systems, can only be provided after an analysis of the specific application, as the fact to be a proven component mainly depends on the specific application.

Christian Jäger
General Manger
Pump & Motor Division Europe



WARNING – USER RESPONSIBILITY

FAILURE OR IMPROPER SELECTION OR IMPROPER USE OF THE PRODUCTS DESCRIBED HEREIN OR RELATED ITEMS CAN CAUSE DEATH, PERSONAL INJURY AND PROPERTY DAMAGE.

This document and other information from Parker-Hannifin Corporation, its subsidiaries and authorized distributors provide product or system options for further investigation by users having technical expertise.

The user, through its own analysis and testing, is solely responsible for making the final selection of the system and components and assuring that all performance, endurance, maintenance, safety and warning requirements of the application are met. The user must analyze all aspects of the application, follow applicable industry standards, and follow the information concerning the product in the current product catalogue and in any other materials provided from Parker or its subsidiaries or authorized distributors.

To the extent that Parker or its subsidiaries or authorized distributors provide component or system options based upon data or specifications provided by the user, the user is responsible for determining that such data and specifications are suitable and sufficient for all applications and reasonably foreseeable uses of the components or systems.

Offer of Sale

Please contact your Parker representation for a detailed "Offer of Sale".



Parker Hannifin Manufacturing Sweden AB
Pump & Motor Division Europe
Flygmotorvägen 2
461 82 Trollhättan
Sweden
Tel. +46 (0)520 40 45 00
www.parker.com/pmde

MSG30-5520-M1/UK

© Copyright 2023
All rights reserved