



aerospace
climate control
electromechanical
filtration
fluid & gas handling
hydraulics
pneumatics
process control
sealing & shielding



PAVC Medium Pressure Super Charged Piston Pumps

Variable Displacement For Open Circuits

Catalog: HY28-2662-CD/US Effective: October 30, 2018

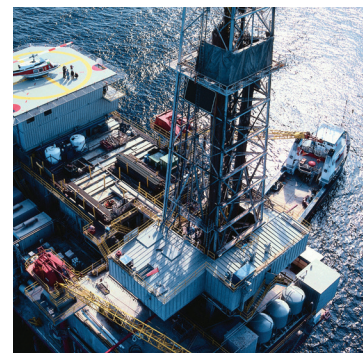

ENGINEERING YOUR SUCCESS.



WARNING - USER RESPONSIBILITY

FAILURE OR IMPROPER SELECTION OR IMPROPER USE OF THE PRODUCTS DESCRIBED HEREIN OR RELATED ITEMS CAN CAUSE DEATH, PERSONAL INJURY AND PROPERTY DAMAGE.

This document and other information from Parker-Hannifin Corporation, its subsidiaries and authorized distributors provide product or system options for further investigation by users having technical expertise.

The user, through its own analysis and testing, is solely responsible for making the final selection of the system and components and assuring that all performance, endurance, maintenance, safety and warning requirements of the application are met. The user must analyze all aspects of the application, follow applicable industry standards, and follow the information concerning the product in the current product catalog and in any other materials provided from Parker or its subsidiaries or authorized distributors.

To the extent that Parker or its subsidiaries or authorized distributors provide component or system options based upon data or specifications provided by the user, the user is responsible for determining that such data and specifications are suitable and sufficient for all applications and reasonably foreseeable uses of the components or systems.

OFFER OF SALE

The items described in this document are hereby offered for sale by Parker-Hannifin Corporation, its subsidiaries or its authorized distributor. This offer and its acceptance are governed by the provisions stated in the detailed "Offer of Sale" elsewhere in this document.

© Copyright 2018, Parker Hannifin Corporation. All Rights Reserved.



Parker Hannifin Corporation
Hydraulic Pump and Power Systems Division
Marysville, Ohio USA

Contents

Contents

Introduction4

Ordering Information7

Control Options 33/38/65/1008

Technical Information13

PAVC 33/38

 Technical Information 33/3814

 Performance Data 33/3815

 Dimensional Data 33/3818

PAVC 65

 Technical Information 65.....20

 Performance Data 65.....21

 Dimensional Data 65.....23

PAVC 100

 Technical Information 100.....26

 Performance Data 100.....27

 Dimensional Data 100.....29

Installation Information 33/38/65/10034

Offer of Sale39



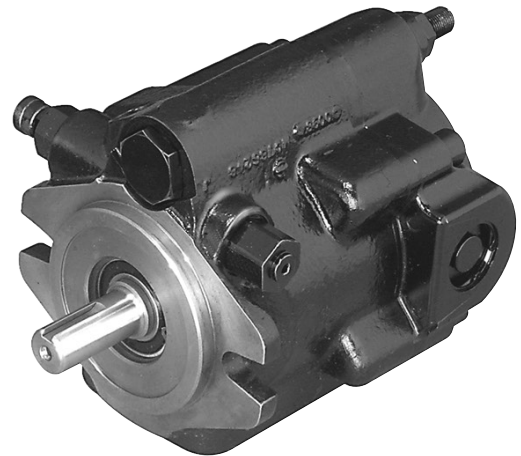

Quick Reference Data Chart

Pump Model	Displacement CM ³ /REV (IN ³ /REV)	Pump Delivery @ 21 bar (300 PSI) in LPM (GPM)		*Approx. Noise Levels dB(A) @ Full Flow 1800 RPM (1200 RPM)				Input Power At 1800 RPM, Maximum Displacement & 207 bar (3000 PSI)	Operating Speed RPM (Maximum)	Pressure bar (PSI) Continuous (Maximum)
		1200 RPM	1800 RPM	34 bar	69 bar	138 bar	207 bar			
				(500 PSI)	(1000 PSI)	(2000 PSI)	(3000 PSI)			
PAVC33	33 (2.0)	39.4 (10.4)	59.0 (15.6)	75 (69)	76 (72)	78 (75)	79 (77)	21.3 kw (28.5 hp)	3000	207 (3000)
PAVC38	38 (2.3)	45.0 (11.9)	67.8 (17.9)	75 (69)	76 (72)	78 (75)	79 (77)	24.6 kw (33.0 hp)	3000	207 (3000)
PAVC65	65 (4.0)	78.7 (20.8)	118.1 (31.2)	77 (75)	78 (76)	80 (78)	81 (79)	43.1 kw (57.8 hp)	3000	207 (3000)
PAVC100	100 (6.1)	119.6 (31.6)	179.8 (47.5)	83 (77)	82 (78)	82 (79)	85 (80)	71.2 kw (95.5 hp)	2600	207 (3000)

* Since many variables such as mounting, tank style, plant layout, etc., effect noise levels, it cannot be assumed that the above readings will be equal to those in the field. The above values are for guidance in selecting the proper pump. Noise levels are A-weighted, mean sound pressure levels at 1 meter from the pump, measured and recorded in accordance with applicable ISO and NFPA standards.



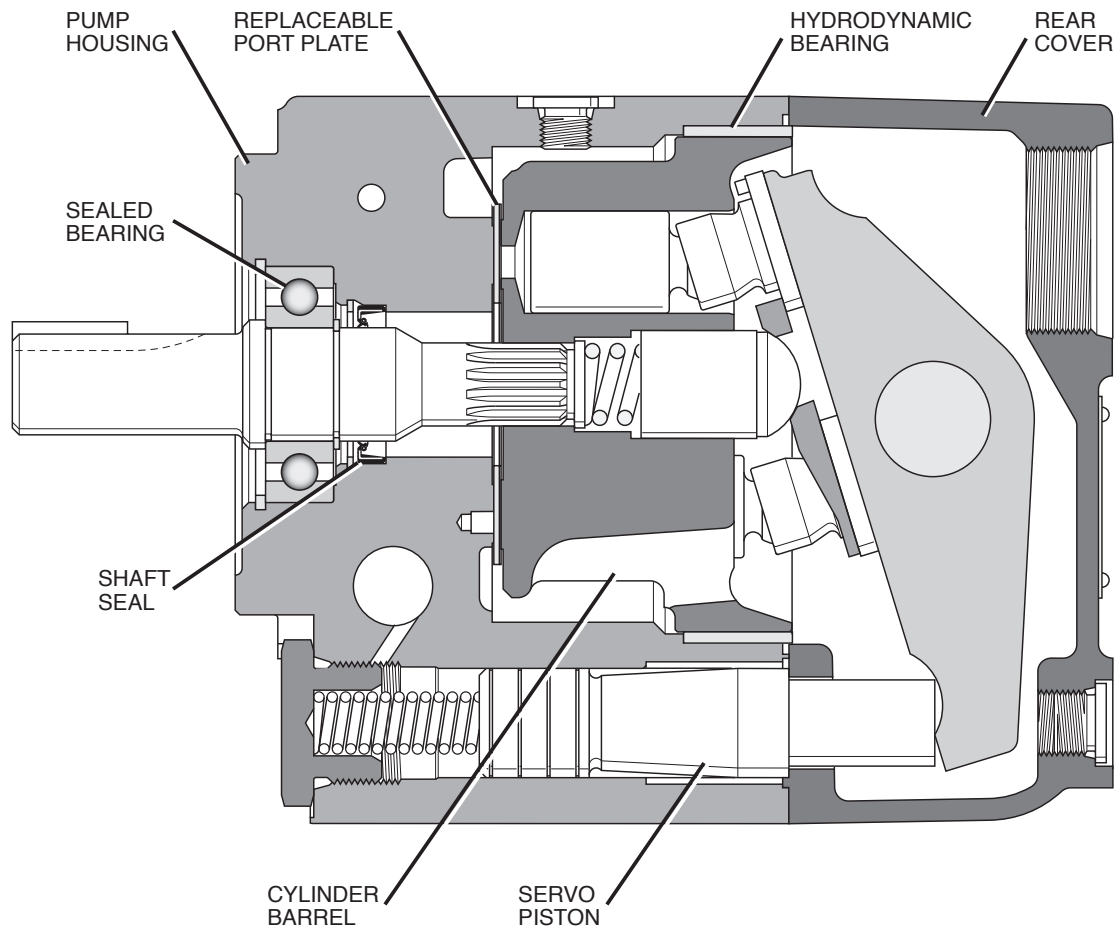

Features

- High Strength Cast-Iron Housing
- Built-In Supercharger Ensures High Speed Capability - 3000 RPM (2600 RPM PAVC100)
- Sealed Shaft Bearing
- Two Piece Design for Ease of Service
- Cartridge Type Controls - Field Changeable
- Replaceable Bronze Clad Port Plate
- Airbleed Standard for Quick Priming
- Hydrodynamic Cylinder Barrel Bearing
- Thru-Shaft (PAVC100 Only)
- Full Pressure Rating on Most Water Glycol Fluids
- Pump Case and Shaft Seal are Subjected to Inlet Pressure Only
- Filter and/or Cool Drain Line
7 bar (100 PSI) Maximum

Controls

- Pressure Compensation
- Load Sensing
- Power (Torque) Limiting
- Power and Load Sensing
- Remote Pressure Compensation
- Adjustable Maximum Volume Stop
- Low Pressure Standby

General Description

All control is achieved by the proper positioning of the swash plate. This is achieved by a servo piston acting on one end of the swash plate working against the combined effect of the off-setting forces of the pistons and centering spring on the other end. The control spool acts as a metering valve which varies the pressure behind the servo piston.

As shown in Figure 1, the amount of flow produced by the Parker Piston Pump is dependent upon the length of stroke of the pumping pistons. This length of stroke, in turn, is determined by the position of the swash plate. Maximum flow is achieved at an angle of 17°.

The rotating piston barrel, driven by the prime mover, moves the pistons in a circular path and the piston slippers are supported hydrostatically against the face of

the swash plate. When the swash plate is in a vertical position, perpendicular to the centerline of the piston barrel, there is no piston stroke and consequently no fluid displacement. When the swash plate is positioned at an angle, the pistons are forced in and out of the barrel and fluid displacement takes place. The greater the angle of the swash plate, the greater the piston stroke.

The centerline of the pumping piston assembly is offset from the centerline of the swash plate. Therefore, as shown on the accompanying Figure 1A, the pistons' effective summation force tends to destroke the swash plate to a vertical (neutral) position. This destroking force is balanced as the swash plate is angled by the force of the servo piston.

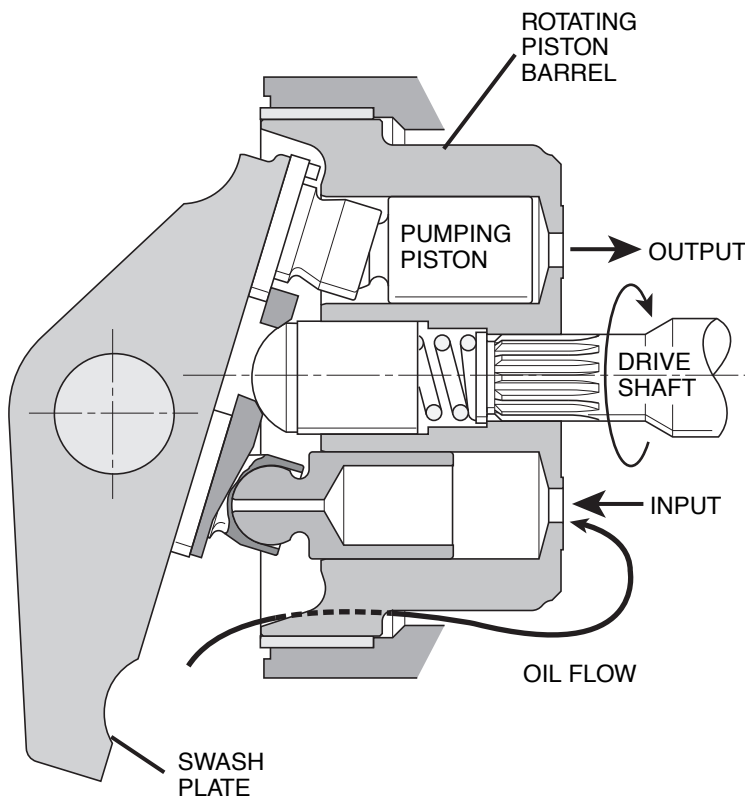

FIGURE 1. Pumping Action

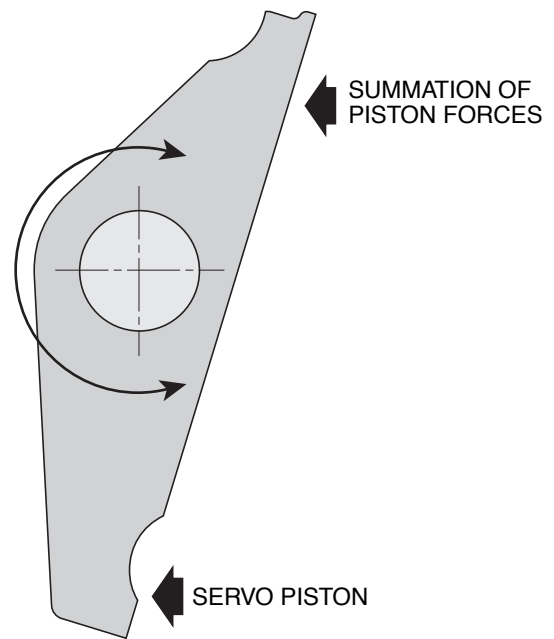
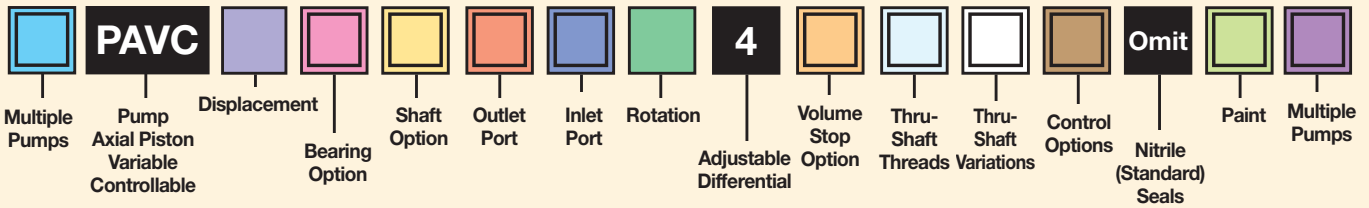

FIGURE 1A.



Code	Multiple Pumps
Omit	Single Pump
—	Factory Mounted to Rear of Another Pump

Code	Displacement in ³ /rev (cm ³ /rev)
33	2.0 (33)
38	2.3 (38)
65	4.0 (65)
100	6.1 (100)

Code	Bearing Option
Omit	Single Piece Shaft
9*	Dual Bearing

* For applications where side loading may be experienced. Max. side load = 113.4 kg (250 lbs).

Typical Applications:

- Belt/chain drive
- Universal joint drive
- Massive couplings
- Foot mount installations

Code	Shaft Option	
	Size 33/38	Size 65/100
Omit	7/8" Keyed SAE B	1¼" Keyed SAE C
B	13T Spline SAE B	14T Spline SAE C
C*	—	1½" Keyed SAE CC

* Size 100 only

Code	Outlet Port		
	Outlet	Location	Type
Omit	Str. Thread	Top	SAE/Inch
3*	Flange	Top	SAE/Inch

* Size 100 only

Code	Inlet Port			
	33/38 Inlet	65 Inlet	100 Inlet	Type
Omit	Str. Thd., Rear	Str. Thd., Rear	Flange, Rear	SAE/Inch Threads
2	Flange, Side	Flange, Top	Flange, Top/Bottom	SAE/Inch Threads

Code	Rotation*
R	Right CW
L	Left CCW

* Viewed from shaft end.

Code	Volume Stop Options
Omit	Volume Stop Plugged
2	Maximum Volume Stop
5*	Max. Volume Stop with O-ring

* Not available with Thru-Shaft option on Size 100.

Code	Thru-Shaft Threads*
Omit	No Thru-Shaft
6	Thru-Shaft, UNC

* Available on Size 100 only.

Code	Thru-Shaft Variations
Omit	No Thru-Shaft Option
A4	Thru-Shaft, SAE A Pilot, 9 Tooth 16/32 Pitch Spline Coupling, PAVC 100 Only
*B3	Thru-Shaft, SAE B Pilot, 13 Tooth 16/32 Pitch Spline Coupling, PAVC 100 Only
*C3	Thru-Shaft, SAE C Pilot, 14 Tooth 12/24 Pitch Spline Coupling, PAVC 100 Only

Inlet port option "2" or "8" (top/bottom) must be used with all Thru-Shaft pumps.

* Use SAE C-C shaft on thru-shaft pump variation when combined input torque of front and rear pumps exceeds 565 N•m (5000 In-Lbs).

Code	Control Option
Omit	Standard Pressure Compensated Setting Pressure 41-207 bar (600-3000 PSI)
A	Pressure & Flow (Load Sensing)
*C	Pressure, Flow & Power
*H	Pressure Comp. & Power
**†M	Remote Pressure
**†ME	Remote Pressure
†AM	Remote Pressure & Flow
*†CM	Remote Pressure, Flow & Power
*†HM	Remote Pressure & Power

* Power controlled pumps (H, C, HM or CM) must have maximum input power limit specifications at a particular drive speed (RPM) and compensator pressure setting (PSI) included with order. Power controlled pumps that do not have input power limit specifications, will be set at default setting (22.5 HP @ 1800 RPM and 3000 PSI) "H" & "C" (60 HP @ 1800 RPM and 3000 PSI) "HM" & "CM"

** "M" may be remotely controlled; "ME" requires external pilot

† Pumps with M, ME, AM, CM or HM controls will be set to compensate at 207 bar (3000 PSI) unless Chart #1 specifies otherwise.

Code	Painting
Omit	No Paint
P	Paint

Code	Multiple Pumps
Omit	Single Pump
—	Pump Factory Mounted on Rear

Chart #1

Item	Setting
RPM	—
PSI	—
HP	—
GPM	—

Ordering Notes

Unless otherwise specified, pump is shipped at maximum GPM (1800 RPM) and set to 69 bar (1000 PSI) [See † Exceptions].

When factory settings are required, the items shown in Chart #1 must be included with order.

= Omit if not required or to select standard option coded "omit".

Pressure Compensated Control

Swash plate angle controls the output flow of the pump. Swash plate angle is controlled by the force generated against the swash plate by the pumping pistons and by the force of the servo piston. The force of the servo piston is greater than the force of the pumping pistons when both are at the same pressure.

By means of internal porting, pressure is connected from the output port to the servo piston via orifice (E), and to the control spool via passage (D). Also pressure is applied to the control spool chamber thru orifice (F). As long as the pressures at both ends of the control spool remain equal, the spool will remain offset upward, due to the added force of the spring.

When pressure reaches the setting of the compensator control, the dart leaves its seat causing the pressure in the spool chamber to be reduced. The spool now moves downward causing pressure in the servo piston cavity to vent via port "A". The reduced pressure at the servo piston allows the servo piston to move to the right. This movement reduces the angle of the swash plate and thereby reduces the pumps output flow.

As pump pressure on the control spool drops below pressure and spring force in the spool chamber, the control spool moves upward to maintain an equilibrium on both sides of the spool. If pump pressure falls below

compensator control setting, the control spool moves up, bringing the pump to maximum displacement.

ΔP Adjustment of PAVC Pumps

PROCEDURE:

a. Standard Pressure Compensated Pump

Pumps are shipped from factory with a differential pressure of approximately 150 PSI (10 bar) on PAVC 33/38/65, PAVC 100 is 300 PSI (21 bar) at 50% of maximum swash angle. Differential pressure will not normally change through the life of the pump. If this control has been tampered with, a close **approximation** of the correct setting can be made as follows:

Dead head the pump (no flow) with a 0-207 bar (0-3000 PSI) gauge in the **OUTLET** (not the low signal "B" port), back the pressure compensator adjustment out (full counterclockwise).

The gauge should read between 22-26 bar (325-375 PSI) PAVC 33, 38 & 65, 34-40 bar (500-575 PSI) PAVC 100. If the gauge reads different than this, turn the differential adjustment knob (Differential Option 4) or add/remove shims (Omit Option) until correct pressure figure is reached.

CONTROL OPTION - 'OMIT'

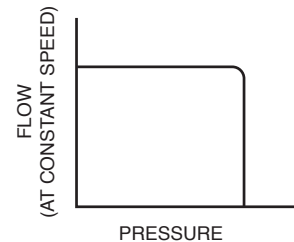
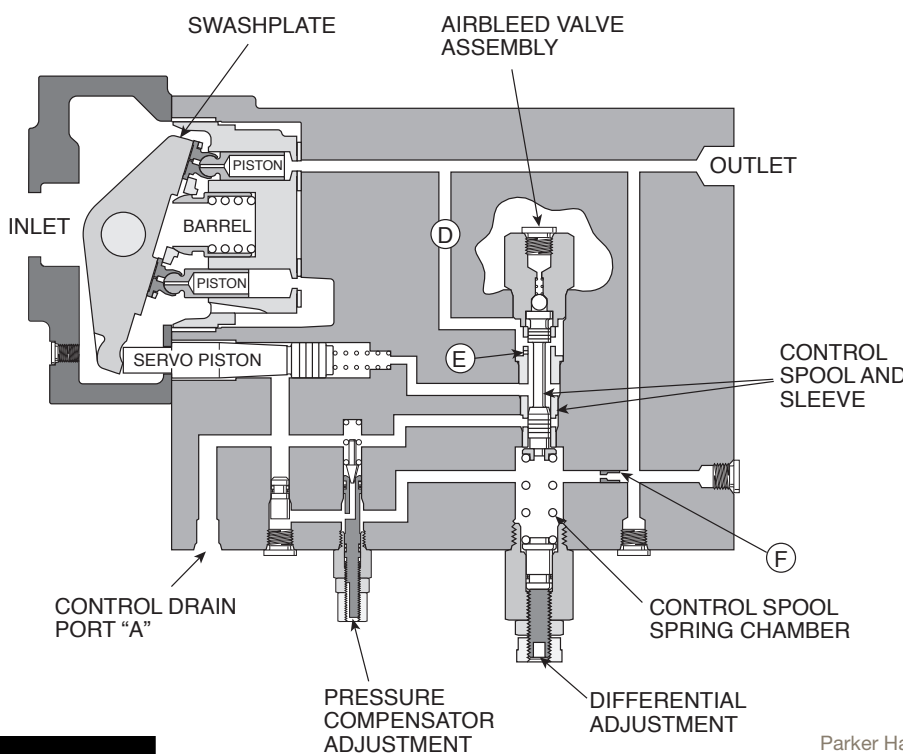

Remote Pressure Control

Control Type (M)

Remote control of the PAVC output pressure can be achieved by controlling the pressure in the low signal “B” port when the pump is set up for Control Type (M). A manual, hydraulically piloted, electrical or electro-proportionally controlled pressure control device is installed in the line from the low signal “B” port to tank. The pump will then maintain pressure approximately equal to the pressure in the “B” port plus the pump differential setting.

Low Pressure Standby

This option can be used as an alternative to the load sensing option (A) to achieve low pressure standby. Minimum standby pressure is somewhat higher than that achieved using option (A). In the compensating mode there is approximately 1.1 LPM (.3 GPM) flow from the low signal “B” port in addition to 3.4 LPM (.9 GPM) flow from the control drain port “A”.

Multiple Pressure Standby

If the pressure level in the low signal “B” port is limited by a relief valve, as the desired pump outlet pressure is reached, the relief valve in the “B” port will allow the pump to standby at a preset pressure. Adding to this concept, multiple, remotely piloted relief valves plumbed in parallel in the “B” port line can yield multiple, sequential pressure settings.

CONTROL OPTION - ‘M’

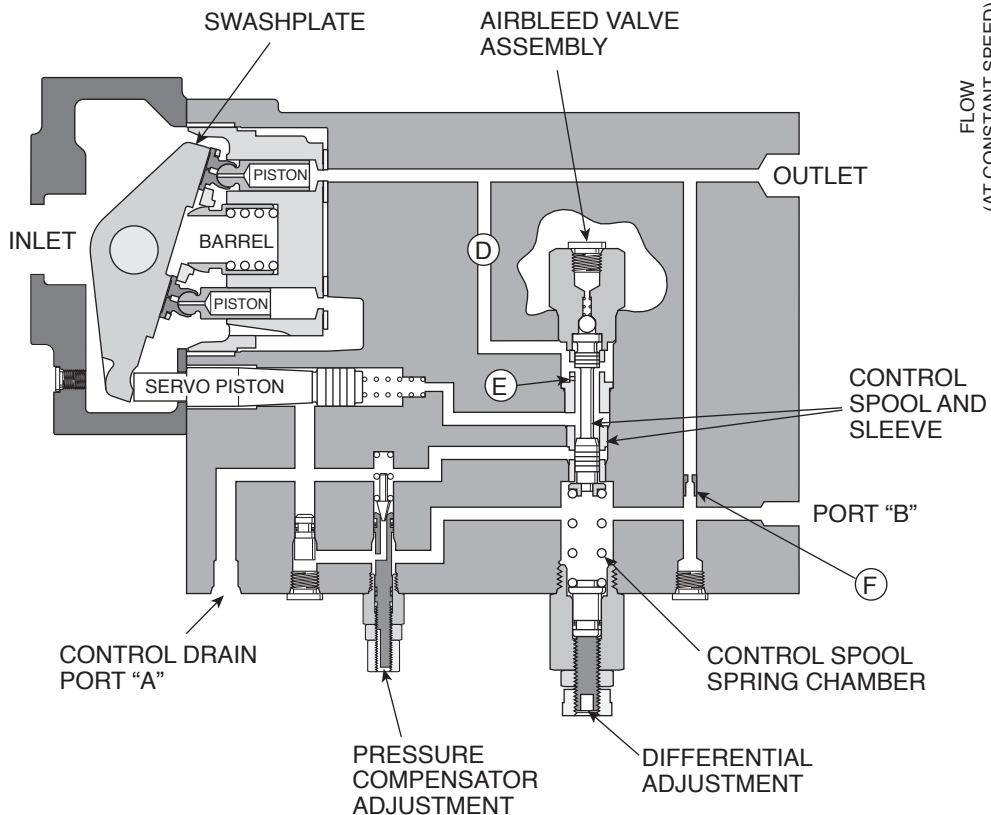

**Pressure & Flow Control (Load Sensing)
 Control Type (A)**

Flow control is achieved by placing an orifice (fixed or adjustable) in the pump outlet port. The pressure drop (ΔP) across this flow control is the governing signal that controls the pump's output, as explained below.

Whenever the pressure drop at the flow control increases (indicating an increase in output flow), the pump attempts to compensate by decreasing the output flow. It does this by sensing the lower pressure on the downstream side of the flow control via line (C), which is balanced against the pump pressure via passage (D), on the control spool. The control spool is forced down against the control spool spring by differential pressure. This vents the servo piston cavity, destroying the pump to a point where the set pressure drop across the orifice is maintained and the flow is obtained.

The converse of this is also true whenever the pressure drop decreases (indicating a decrease in output flow). In this case, the control spool is forced up. This increases pump displacement in an attempt to maintain the predetermined pressure drop or constant flow.

It should be noted that the pump is still pressure compensated and destrokes at the selected pressure setting. The pressure compensator control will override the flow control whenever the pressure compensator control setting is reached.

Low Pressure Standby

This arrangement can also be used to provide low pressure standby by venting the "B" port through a simple on/off valve suitable for flows of 3.8-7.6 LPM (1-2 GPM). When flow or pressure is required, this valve is closed allowing system pressure to build behind the control spool and bringing the pump on-stroke.

Load Sensing

If, instead of measuring the pressure drop across the orifice in the pump outlet port, it is measured downstream of a directional control valve, a constant pressure drop will be maintained across the valve spool. This results in a constant flow for any given opening of the directional control valve regardless of the work load downstream or the operating speed of the pump.

The pump "senses" the amount of pressure necessary to move the load and adjusts output flow to match the valve opening selected and pressure to overcome the load plus the preset ΔP across the valve spool.

The benefits of this arrangement are that excellent, repeatable flow characteristics are achieved, and considerable energy savings are realized while metering, compared to using a straight pressure compensated system.

CONTROL OPTION - 'A'

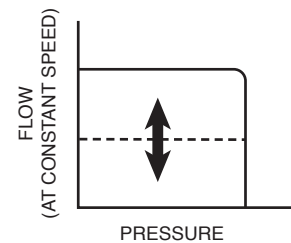
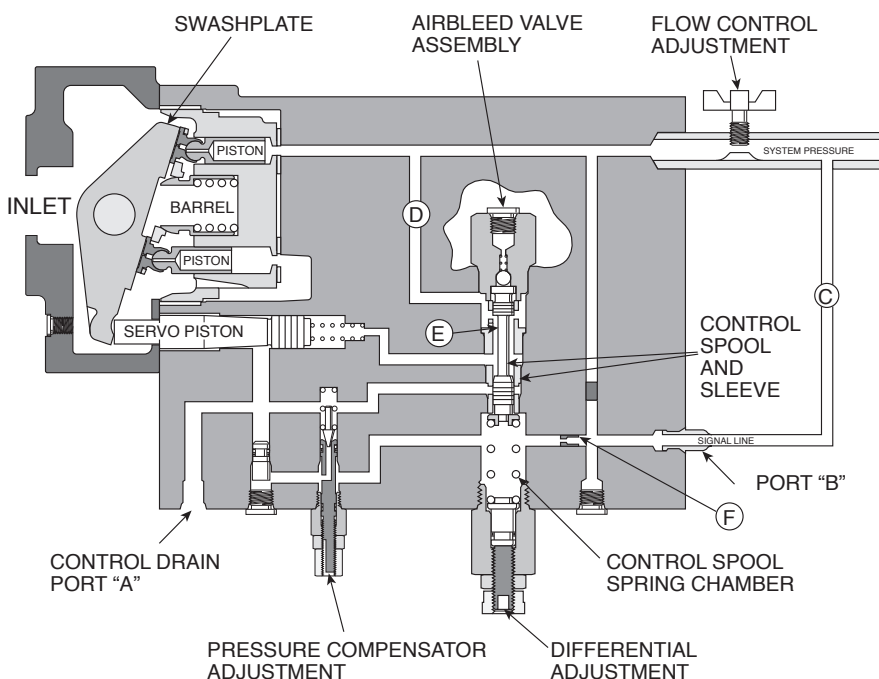

**Pressure & Power (Torque) Control
 Control Type (H)**

The power control is sensitive to the position of the servo piston. When the servo piston is to the right, the swash plate causes low flow and the power control piston develops maximum spring pressure on its companion poppet (mechanical feedback). When the servo piston is left and the flow is high, the power control piston reduces spring pressure on the poppet. This allows it to open under less pressure in the control spool chamber, thereby venting some of the pressure in the control spool chamber. As with the operation of the pressure compensator control, this allows the control

spool to move downward, venting the servo piston cavity and causing the servo piston to move to the right. This reduces output flow and thereby power.

As indicated in the pictorial drawing, pressure in the control spool chamber is affected by both the pressure compensator control and the power control. The resultant pressure in this chamber is a function of the set points of these two controls. Both set points are adjustable.

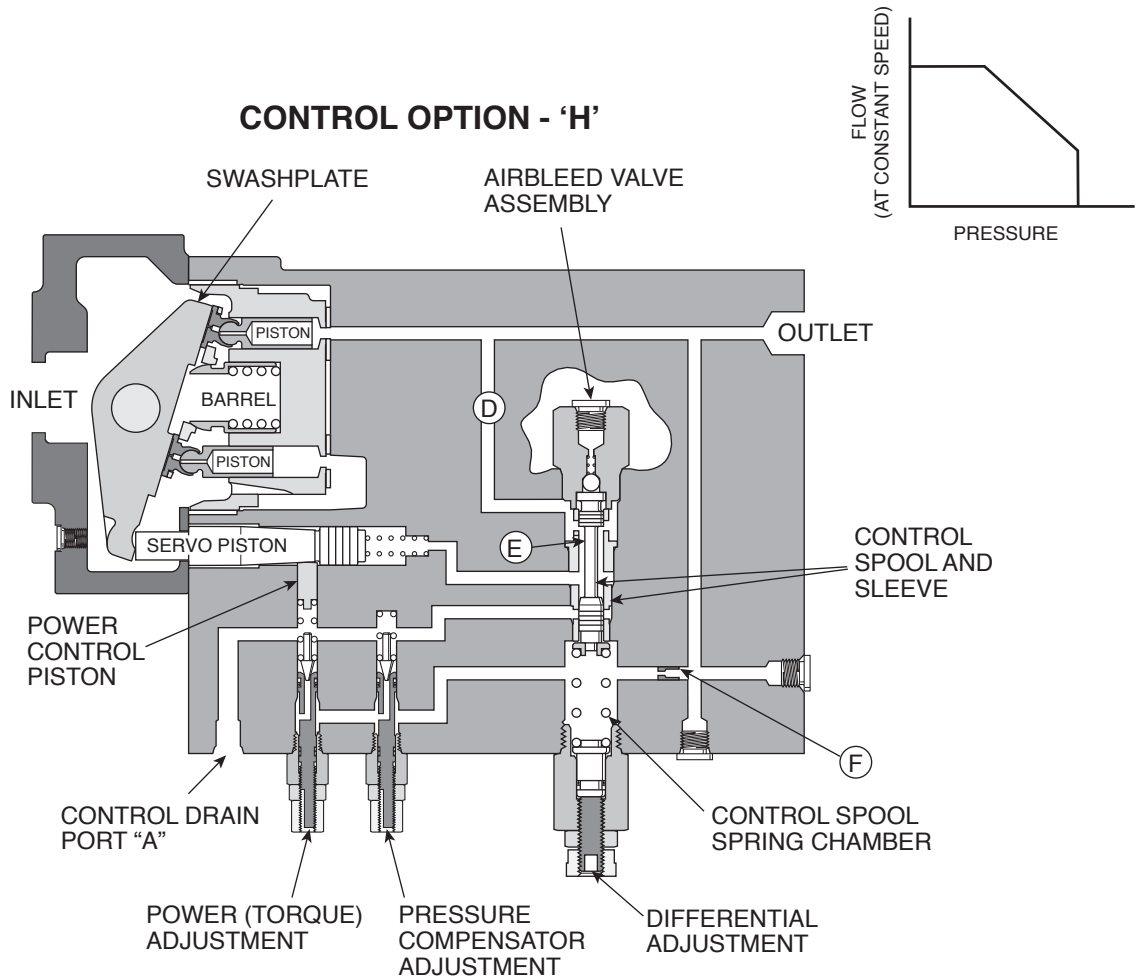

**Pressure, Power & Flow Control
 Control Type (C)**

In addition to the three control configurations just discussed, it is possible to combine all three control devices in one pump. In this mode, the position of the control spool is a function of the actions of the pressure compensator adjustment, power adjustment, and flow control.

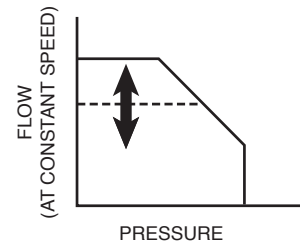

CONTROL OPTION - 'C'

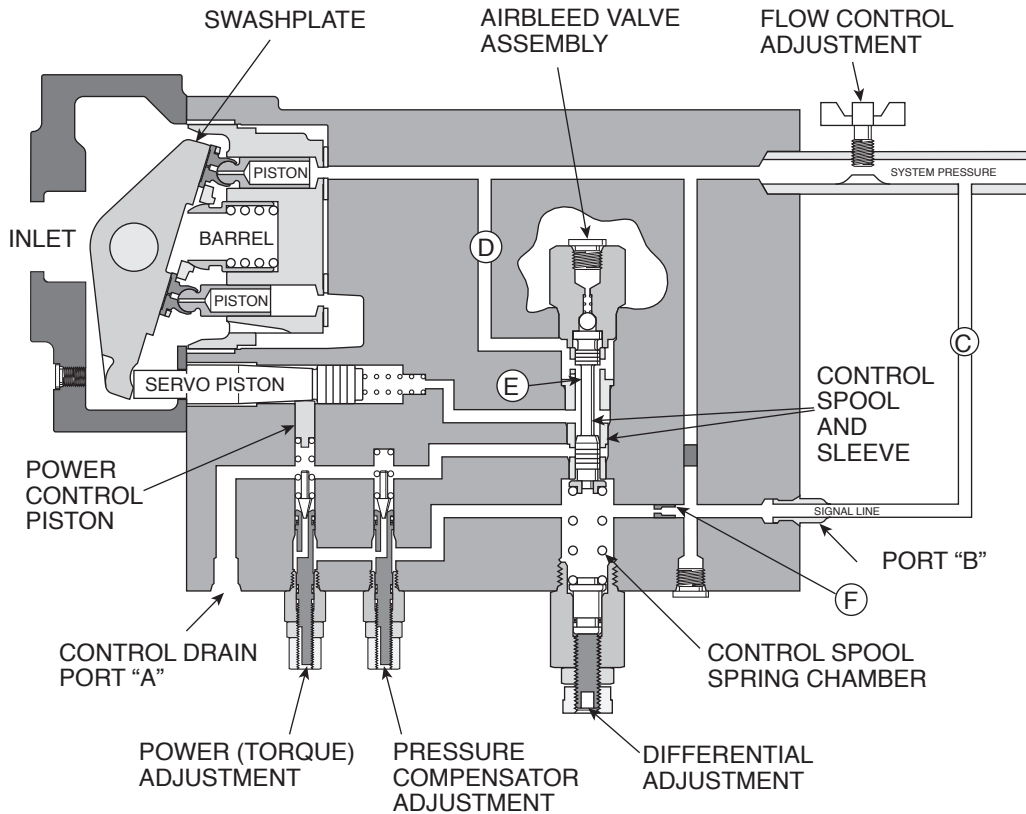

How to read input power control curve data.

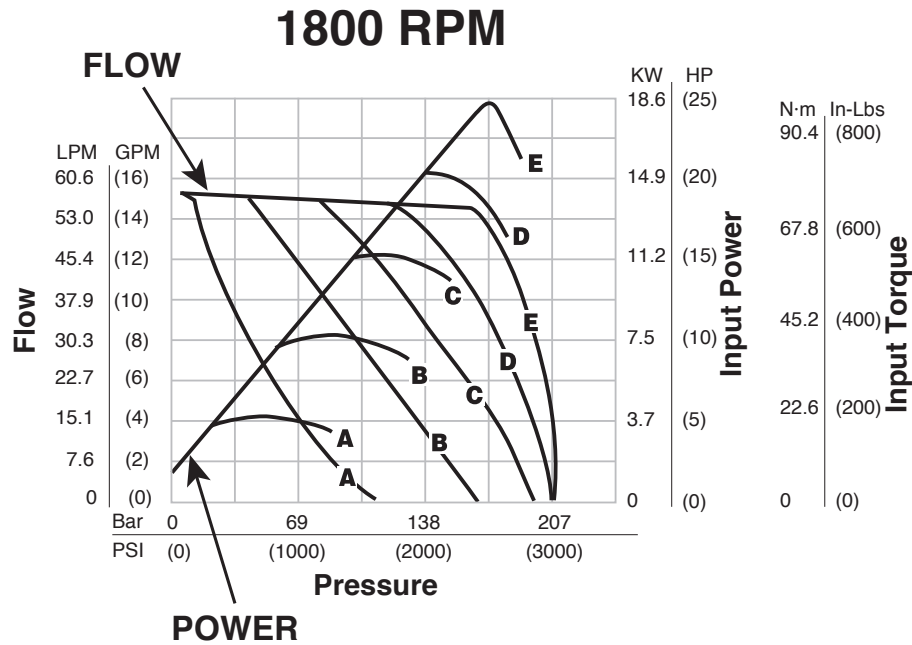

1. Power “A” curve corresponds to flow “A” curve. This represents a particular setting of the power (torque) control.
2. With this setting the maximum power required will be as shown at the apex (maximum point) of the power curve.
3. The flow at this setting will follow the flow vs. pressure curve shown.
4. Example – 1800 RPM, curve labeled “C”:
 - A. Flow will follow curve “C” and pump will deadhead at 190 bar (2750 PSI).
 - B. Full flow will not be realized above 83 bar (1200 PSI).
 - C. Flow at 103 bar (1500 PSI) will be approximately 48.1 LPM (12.7 GPM).
 - D. Maximum power [11 KW (15 HP)] occurs at approximately 117 bar (1700 PSI).
5. Torque values are shown to correspond to powers at speed shown.

Performance Information

Series PAVC 33/38 Pressure Compensated, Variable Volume, Piston Pumps

Features

- High Strength Cast-Iron Housing
- Built-In Supercharger
- High Speed Capability – 3000 RPM
- Two Piece Design for Ease of Service
- Cartridge Type Controls – Field Changeable
- Replaceable Bronze Clad Port Plate
- Airbleed Standard for Quick Priming
- Hydrodynamic Cylinder Barrel Bearing
- Full Pressure Rating on Water Glycol Fluids
- Filtered and/or Cooled Drain Line Capable 7 bar (100 PSI) Maximum

Controls

- Pressure Compensation
- Remote Pressure Compensation
- Load Sensing
- Power (Torque) Limiting
- Power Limiting and Load Sensing
- Adjustable Maximum Volume Stop
- Low Pressure Standby

Schematic Symbol

(Basic Pump)

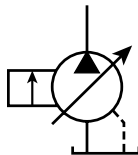

Weight and Package Size

Model	Weight In Kg (Lb)	Length From Mounting Face in CM (Inches)	Height in CM (Inches)	Height in CM (Inches)
PAVC 33/38	18 (40)	18.41 (7.25)	16.00 (6.30)	16.81 (6.62)

Quick Reference Data Chart

Pump Model	Displacement CM ³ /REV (IN ³ /REV)	Pump Delivery @ 21 bar (300 PSI) in LPM (GPM)		*Approx. Noise Levels dB(A) @ Full Flow 1800 RPM (1200 RPM)				Input Power At 1800 RPM, Max. Displacement & 207 bar (3000 PSI)
		1200 RPM	1800 RPM	34 bar (500 PSI)	69 bar (1000 PSI)	138 bar (2000 PSI)	207 bar (3000 PSI)	
PAVC33	33 (2.0)	39.4 (10.4)	59.0 (15.6)	75 (69)	76 (72)	78 (75)	79 (77)	21.3 kw (28.5 hp)
PAVC38	38 (2.3)	45.0 (11.9)	67.8 (17.9)	75 (69)	76 (72)	78 (75)	79 (77)	24.6 kw (33.0 hp)

* Since many variables such as mounting, tank style, plant layout, etc., effect noise levels, it cannot be assumed that the above readings will be equal to those in the field. The above values are for guidance in selecting the proper pump. Noise levels are A-weighted, mean sound pressure levels at 1 meter from the pump, measured and recorded in accordance with applicable ISO and NFPA standards.

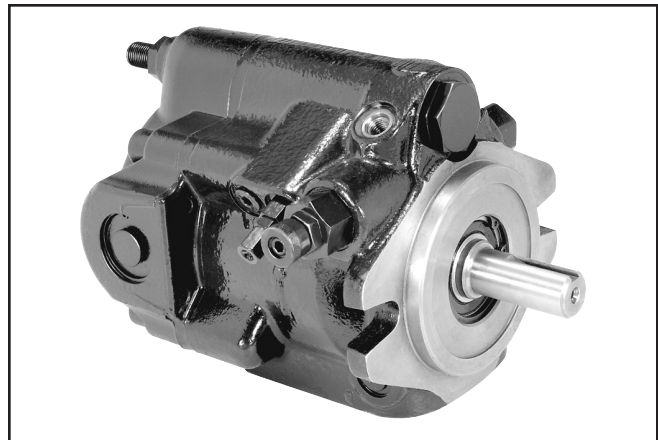

Specifications

Pressure Ratings:

Outlet Port: 207 bar (3000 PSI) Continuous (P1)
 248 bar (3600 PSI) Peak (P3)

Inlet Port: 1.72 bar (25 PSI) Maximum
 0.17 bar (5 In. Hg.) Minimum @ 1800 RPM (See Inlet Chart for other speeds)

Control Drain: 7 bar (100 PSI) Maximum

Speed Ratings: 600 to 3000 RPM

Operating Temperature Range: – 40°C to 71°C
 (– 40°F to 160°F)

Housing Material: Cast-Iron

Filtration: Maintain SAE Class 4, ISO 16/13, ISO 18/15 Maximum Recommended

Mounting: SAE B 2-Bolt Flange Mount or Diagonally on SAE B 4-Bolt Flange Mount.

Installation Data: See page A46 of this catalog for specific recommendations pertaining to system cleanliness, fluids, start-up, inlet conditions, shaft alignment, drain line restrictions and other important factors relative to the proper installation and use of these pumps.

Typical Performance Data - Fluid: Standard Hydraulic Oil 100 SSU @ 49°C (120°F)

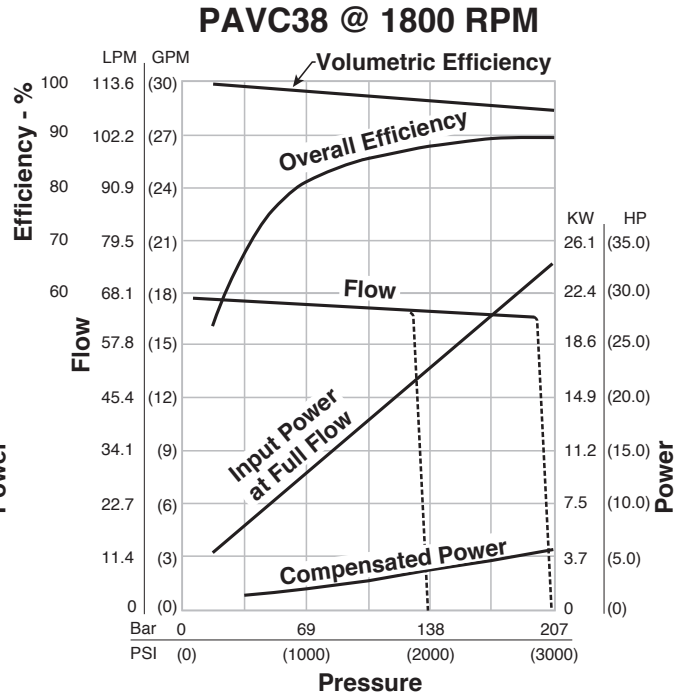
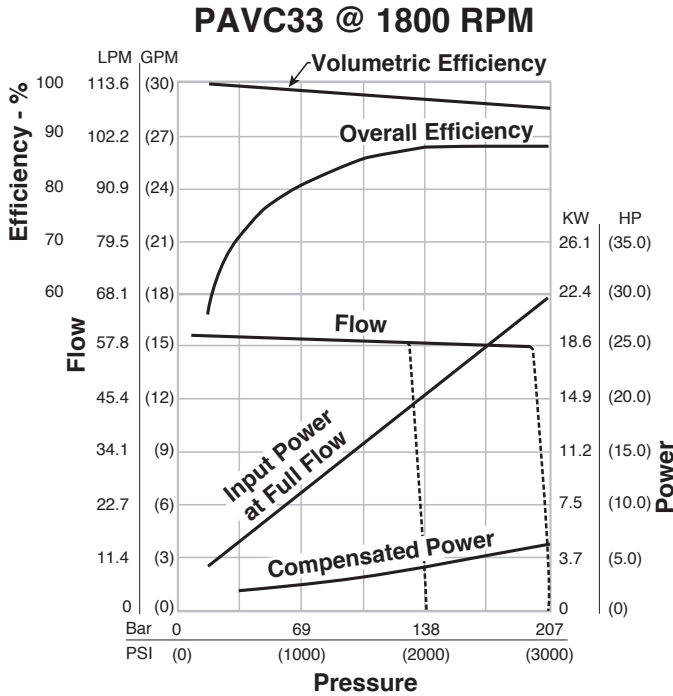

NOTE: The efficiencies and data in the graph are good only for pumps running at 1800 RPM and stroked to maximum. To calculate approximate input power for the other conditions, use the following formula:

$$HP = \left[\frac{Q \times (PSI)}{1714} \right] + (CHp)$$

WHERE:

- Q = Actual Output Flow in GPM
- PSI = Pressure At Pump Outlet
- CHp = Input Power @ Full Compensation @ 1800 RPM (from graph read at operating pressure)

Actual GPM is directly proportional to drive speed and maximum volume setting. Flow loss, however, is a function of pressure only.

Inlet Characteristics at Full Displacement
 (Graph only valid at sea level)

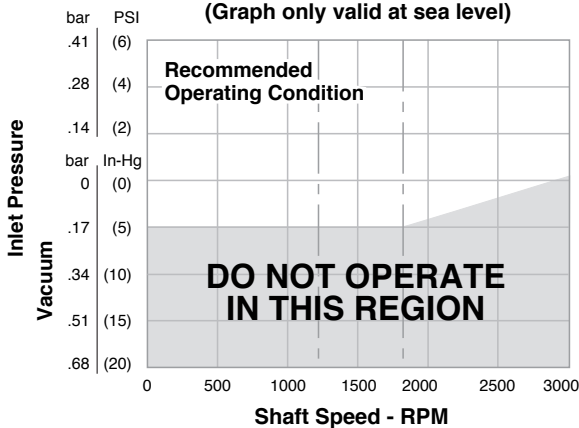

Compensated Control Drain Flow @ 1800 RPM

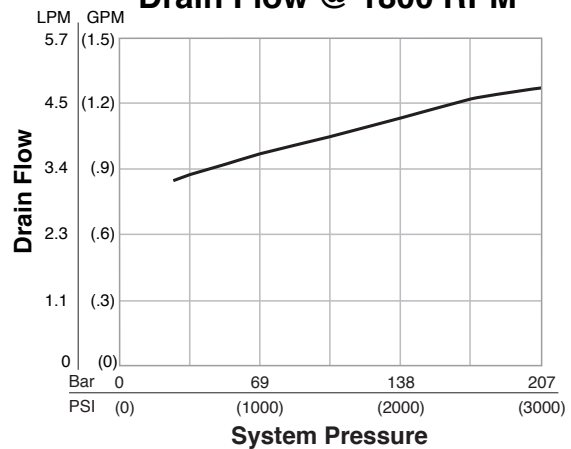

Typical Performance Data

Minimum Power Settings Attainable With Control Options C, H, CM & HM

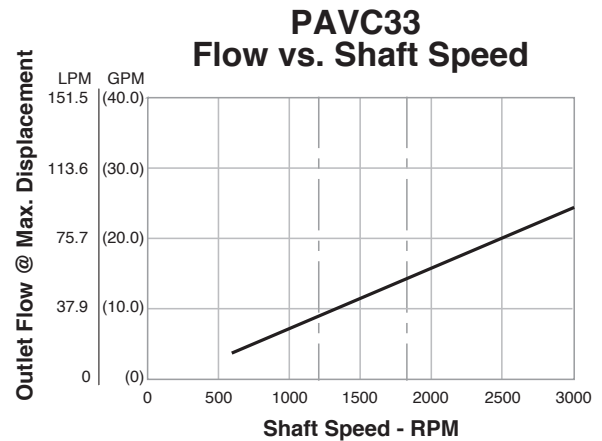
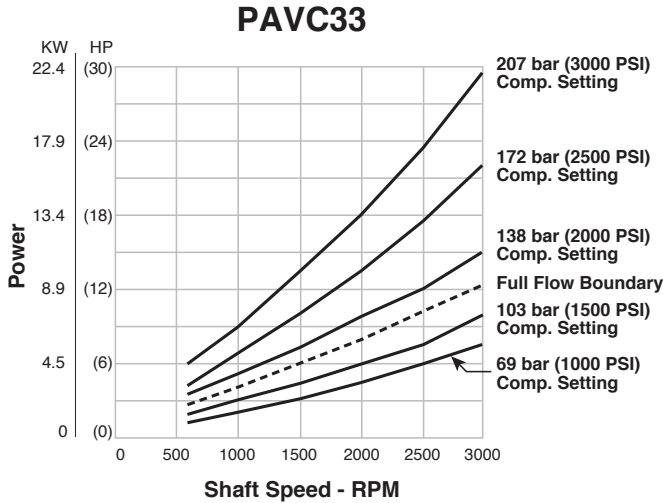

NOTE: Minimum attainable HP setting means that input power will not exceed the indicated setting at the indicated RPM and that the pump will achieve full compensator pressure selected. If setting input power limiter below full flow boundary, full flow may not be obtained at low operating pressure.

Determine maximum input power limitation at desired RPM. All points above desired compensator setting curve can be achieved.

Power (Torque) Limiting Curves

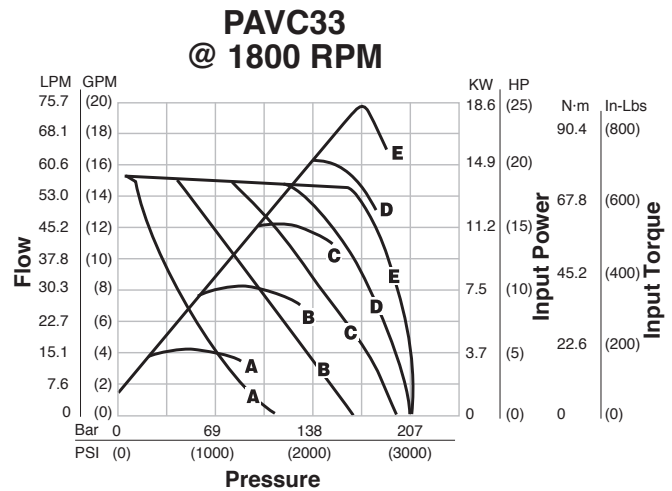
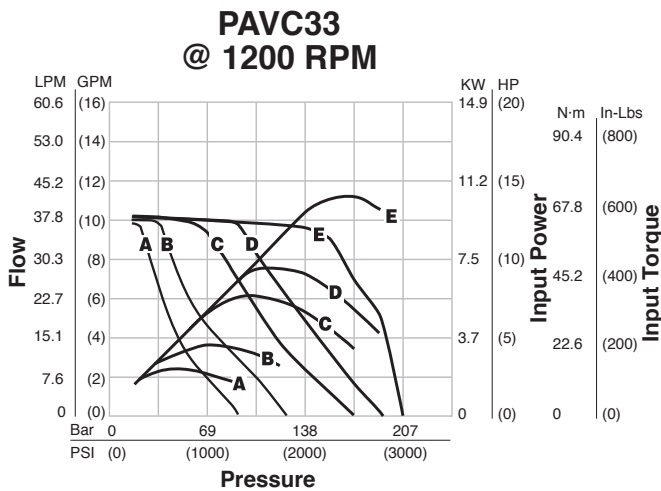

See page 12 for "How to Read Curves" information.



Typical Performance Data

Minimum Power Settings Attainable With Control Options C, H, CM & HM

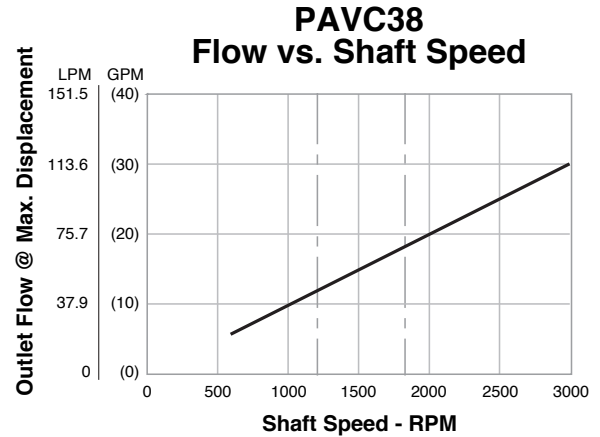
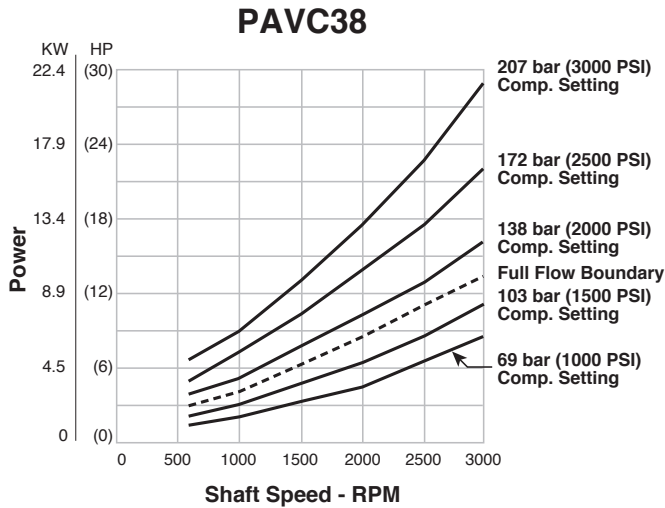

NOTE: Minimum attainable HP setting means that input power will not exceed the indicated setting at the indicated RPM and that the pump will achieve full compensator pressure selected. If setting input power limiter below full flow boundary, full flow may not be obtained at low operating pressure.

Determine maximum input power limitation at desired RPM. All points above desired compensator setting curve can be achieved.

Power (Torque) Limiting Curves

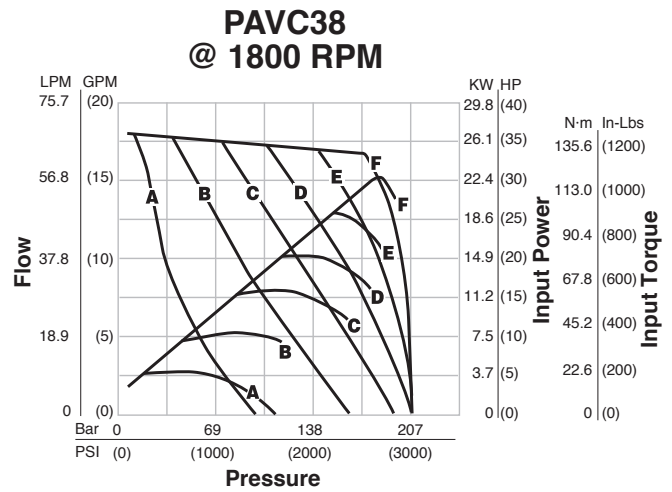
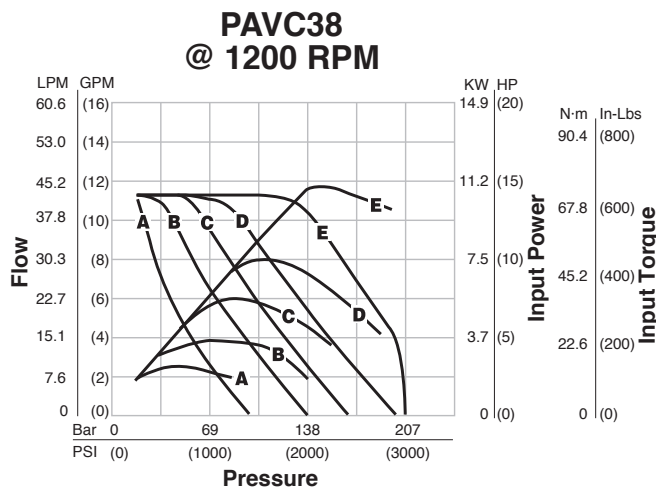

See page 12 for "How to Read Curves" information.

Rear Ported Pump Dimensions

* Inch equivalents for millimeter dimensions are shown in (**).

NOTE:

1. Pump shown and dimensioned is a clockwise rotation pump.
 Outlet port, A and B ports, and controls will be on opposite side for a counterclockwise rotation pump.

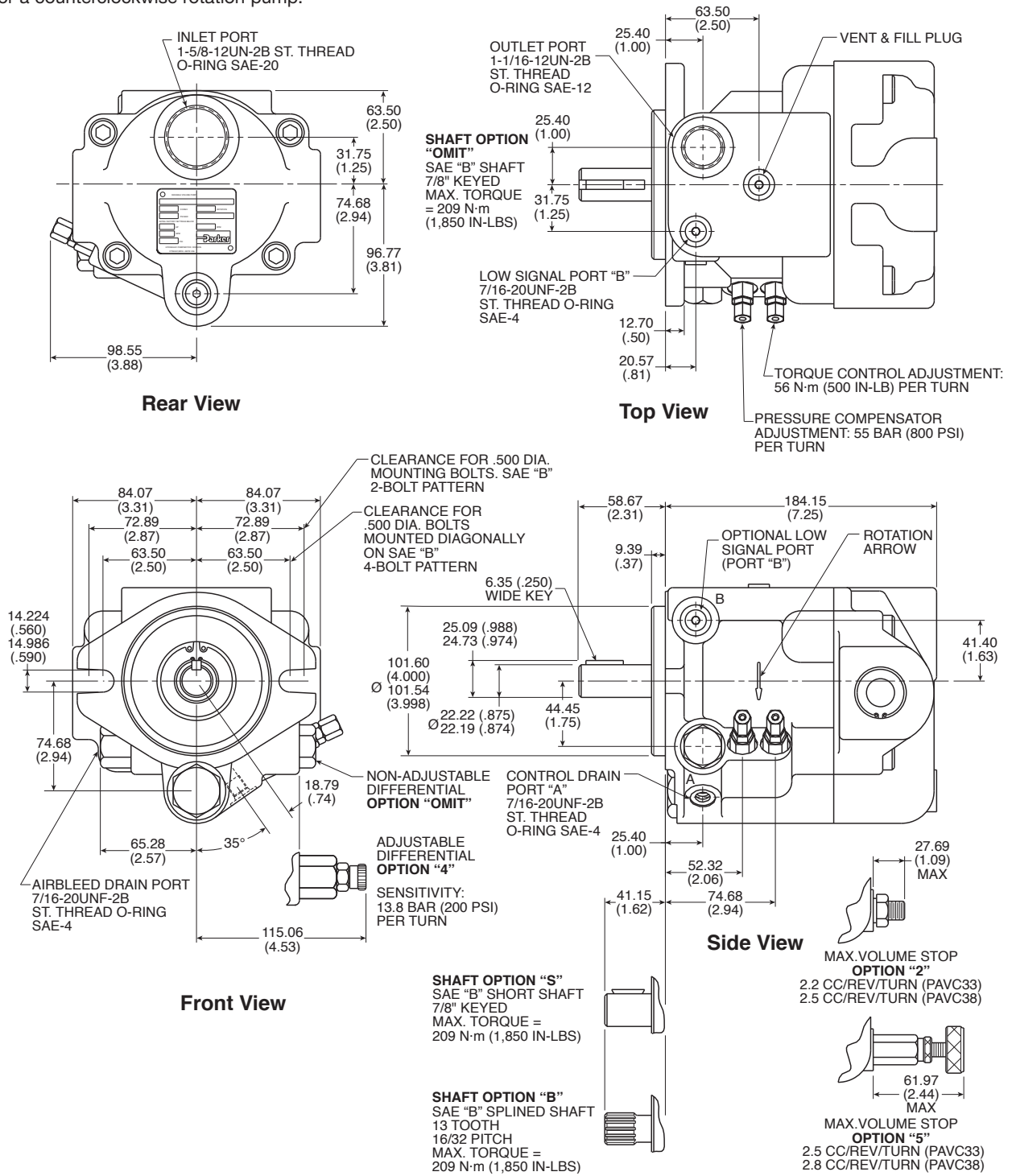

Side Ported – Dimensions

* Inch equivalents for millimeter dimensions are shown in (**).

NOTE:

1. Shown and dimensioned is a clockwise pump. Ports A and B, delivery port and pump controls will be on the opposite side for a counterclockwise pump.

Port Location				
Option	Outlet Port	Inlet Port	Control Drain	Signal Port
2	SAE-12 Straight Thread (1-1/16-12UNC)	1-1/4 SAE 4-Bolt Flange 7/16-14UNC Threads Standard Pressure Series (Code 61)	SAE-4 Straight Thread (7/16-20UNF)	SAE-4 Straight Thread (7/16-20UNF)

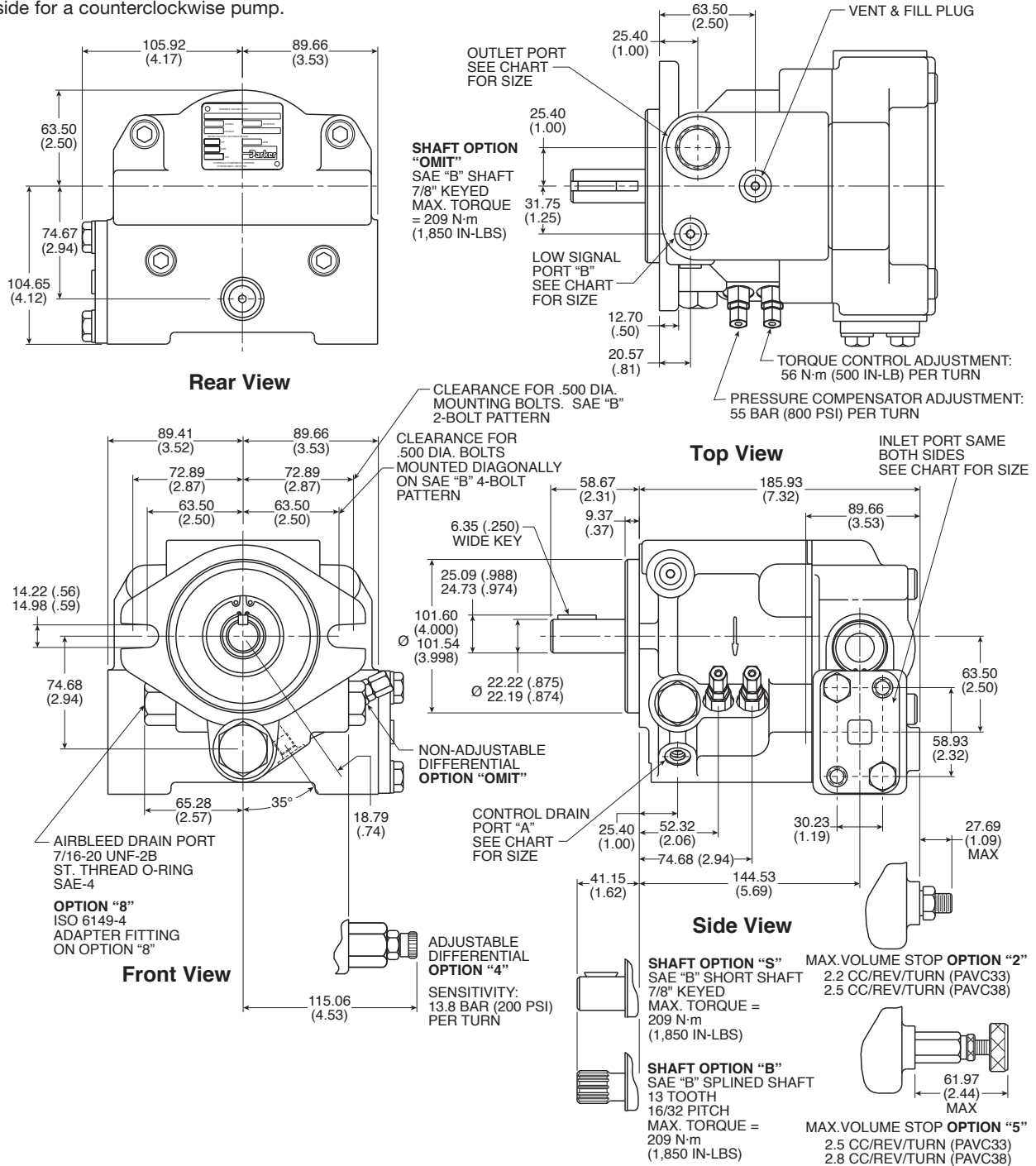

Performance Information

Series PAVC65 Pressure Compensated,
 Variable Volume, Piston Pump

Features

- High Strength Cast-Iron Housing
- Built-In Supercharger
- High Speed Capability - 3000 RPM
- Two Piece Housing for Ease of Service
- Cartridge Type Controls - Field Changeable
- Replaceable Bronze Clad Port Plate
- Airbleed Standard for Quick Priming
- Hydrodynamic Cylinder Barrel Bearing
- Full Pressure Rating on Water Glycol Fluids
- Filtered and/or Cooled Drain Line Capable - 7 bar (100 PSI) Maximum

Controls

- Pressure Compensation
- Remote Pressure Compensation
- Load Sensing
- Power (Torque) Limiting
- Power Limiting and Load Sensing
- Adjustable Maximum Volume Stop
- Low Pressure Standby

Schematic Symbol

(Basic Pump)

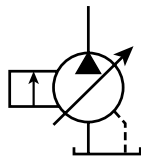

Weight and Package Size

Model	Weight In Kg (Lb)	Length From Mounting Face in CM (Inches)	Height in CM (Inches)	Height in CM (Inches)
PAVC65	28 (62)	22.40 (8.82)	18.84 (7.42)	20.32 (8.00)

Quick Reference Data Chart

Pump Model	Displacement CM ³ /REV (IN ³ /REV)	Pump Delivery @ 21 bar (300 PSI) in LPM (GPM)		*Approx. Noise Levels dB(A) @ Full Flow 1800 RPM (1200 RPM)				Input Power At 1800 RPM, Max. Displacement & 207 bar (3000 PSI)
		1200 RPM	1800 RPM	34 bar (500 PSI)	69 bar (1000 PSI)	138 bar (2000 PSI)	207 bar (3000 PSI)	
				77 (75)	78 (76)	80 (78)	81 (79)	
PAVC65	65 (4.0)	78.7 (20.8)	118.1 (31.2)	77 (75)	78 (76)	80 (78)	81 (79)	43.1 kw (57.8 hp)

* Since many variables such as mounting, tank style, plant layout, etc., effect noise levels, it cannot be assumed that the above readings will be equal to those in the field. The above values are for guidance in selecting the proper pump. Noise levels are A-weighted, mean sound pressure levels at 1 meter from the pump, measured and recorded in accordance with applicable ISO and NFPA standards.

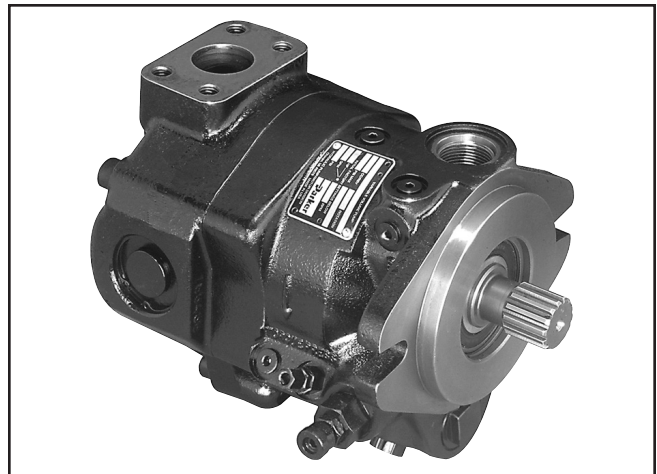

Specifications

Pressure Ratings:

Outlet Port: 207 bar (3000 PSI) Continuous (P1)
 248 bar (3600 PSI) Peak (P3)

Inlet Port: 1.7 bar (25 PSI) Maximum
 0.17 bar (5 In. Hg.) Minimum @ 1800 RPM (See Inlet Chart for other speeds)

Control Drain: 7 bar (100 PSI) Maximum

Speed Ratings: 600 to 3000 RPM*

* See Inlet Characteristics Chart on page A155 and consider using Dual Inlet Port configuration on page A178 for applications above 2700 RPM.

Operating Temperature Range: - 40°C to 71°C
 (- 40°F to 160°F)

Housing Material: Cast-Iron

Filtration: Maintain SAE Class 4, ISO 16/13,
 ISO 18/15 Maximum Recommended

Mounting: SAE C 2-Bolt Flange Mount or Diagonally on SAE C 4-Bolt Flange Mount

Installation Data: See page A46 of this catalog for specific recommendations pertaining to system cleanliness, fluids, start-up, inlet conditions, shaft alignment, drain line restrictions and other important factors relative to the proper installation and use of these pumps.

Typical Performance Data - Fluid: Standard Hydraulic Oil 100 SSU @ 49°C (120°F)

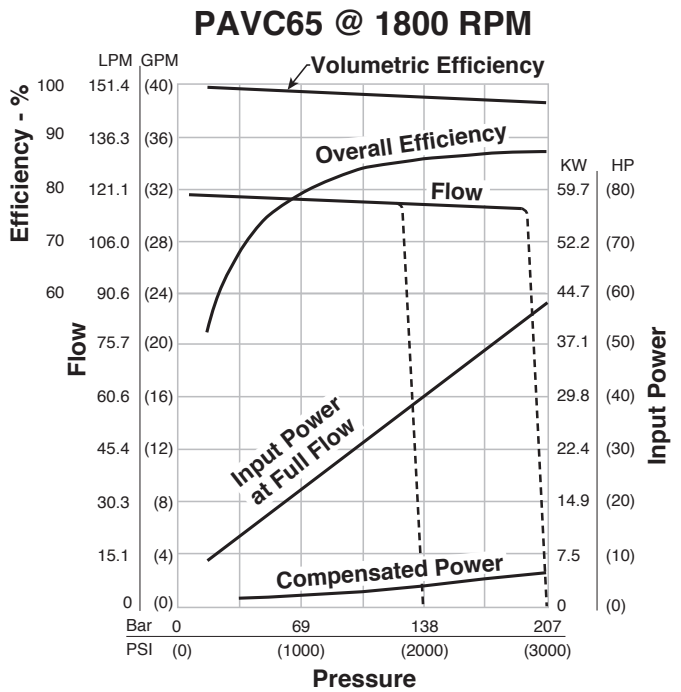
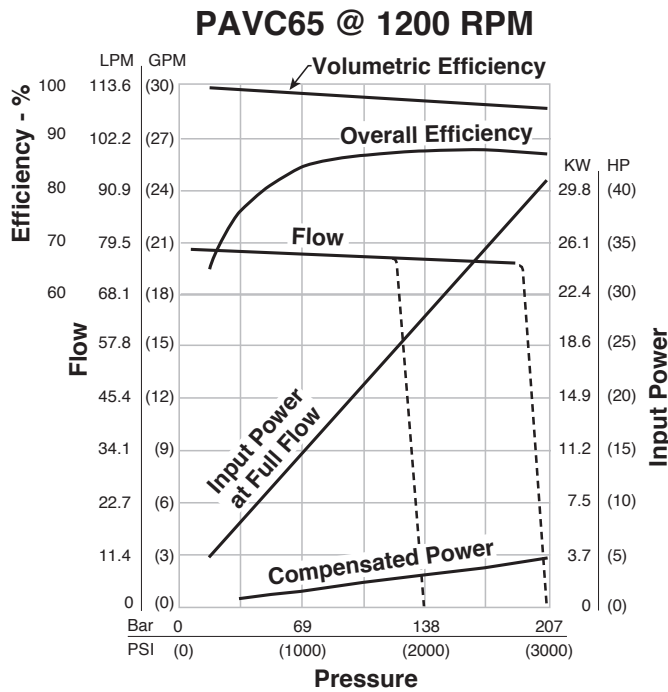

NOTE: The efficiencies and data in the graph are good only for pumps running at 1800 RPM and stroked to maximum. To calculate approximate input power for the other conditions, use the following formula:

$$HP = \left[\frac{Q \times (PSI)}{1714} \right] + (CHp)$$

WHERE:

- Q = Actual Output Flow in GPM
- PSI = Pressure At Pump Outlet
- CHp = Input Power @ Full Compensation @ 1800 RPM (from graph read at operating pressure)

Actual GPM is directly proportional to drive speed and maximum volume setting. Flow loss, however, is a function of pressure only.

Inlet Characteristics at Full Displacement
 (Graph only valid at sea level)

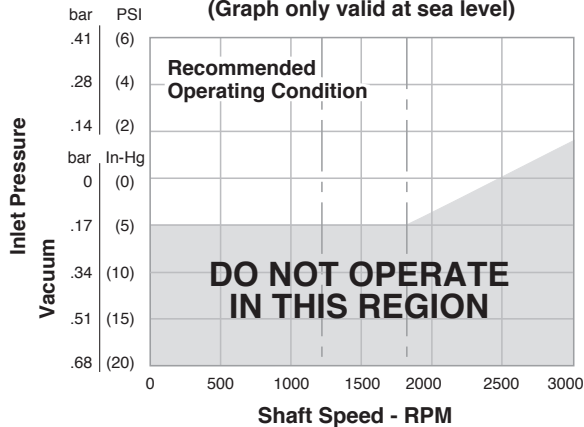

Compensated Control Drain Flow @ 1800 RPM

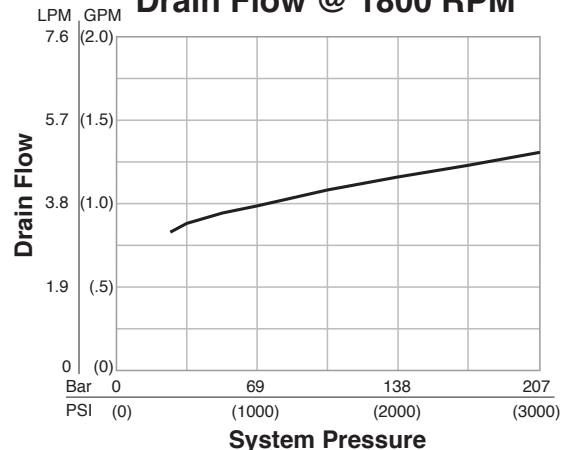

Typical Performance Data

**Minimum Power Settings Attainable
 With Control Options C, H, CM & HM**

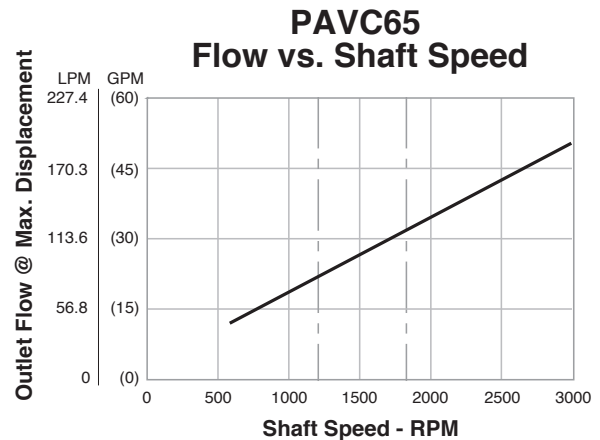
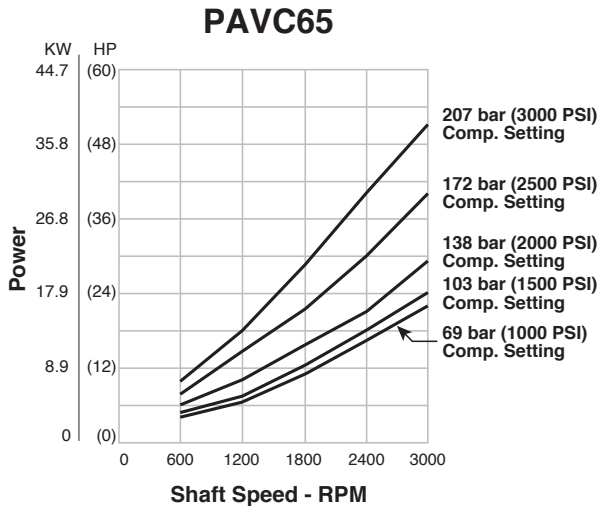

NOTE: Minimum attainable HP setting means that input power will not exceed the indicated setting at the indicated RPM and that the pump will achieve full compensator pressure selected. If setting input power limiter below full flow boundary, full flow may not be obtained at low operating pressure.

Determine maximum input power limitation at desired RPM. All points above desired compensator setting curve can be achieved.

Power (Torque) Limiting Curves

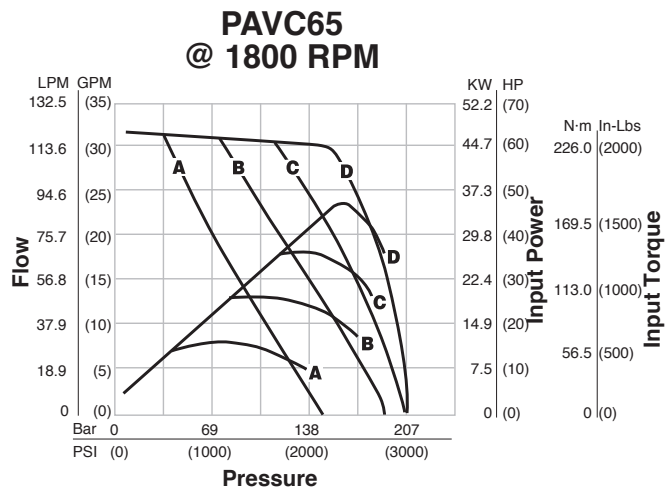
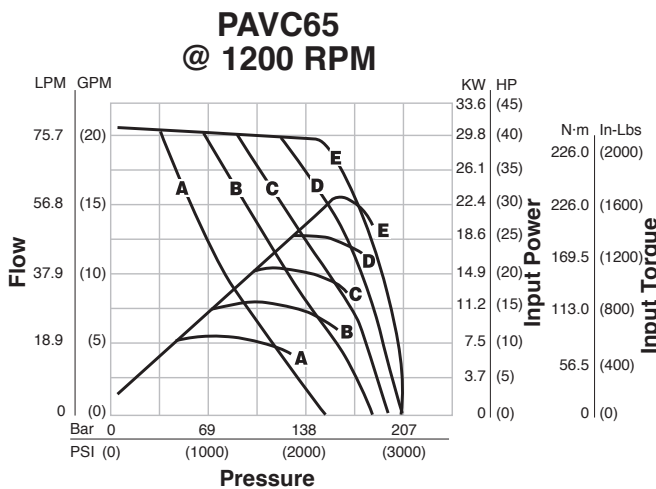

See page 12 for "How to Read Curves" information.



Dimensions – Rear Port

* Inch equivalents for millimeter dimensions are shown in (**).

NOTES:

1. Pump shown and dimensioned is a clockwise rotation pump. Outlet port, A and B ports, and controls will be on opposite side for a counterclockwise rotation pump.
2. Pump mounting and shaft comply with SAE "C" dimensions.

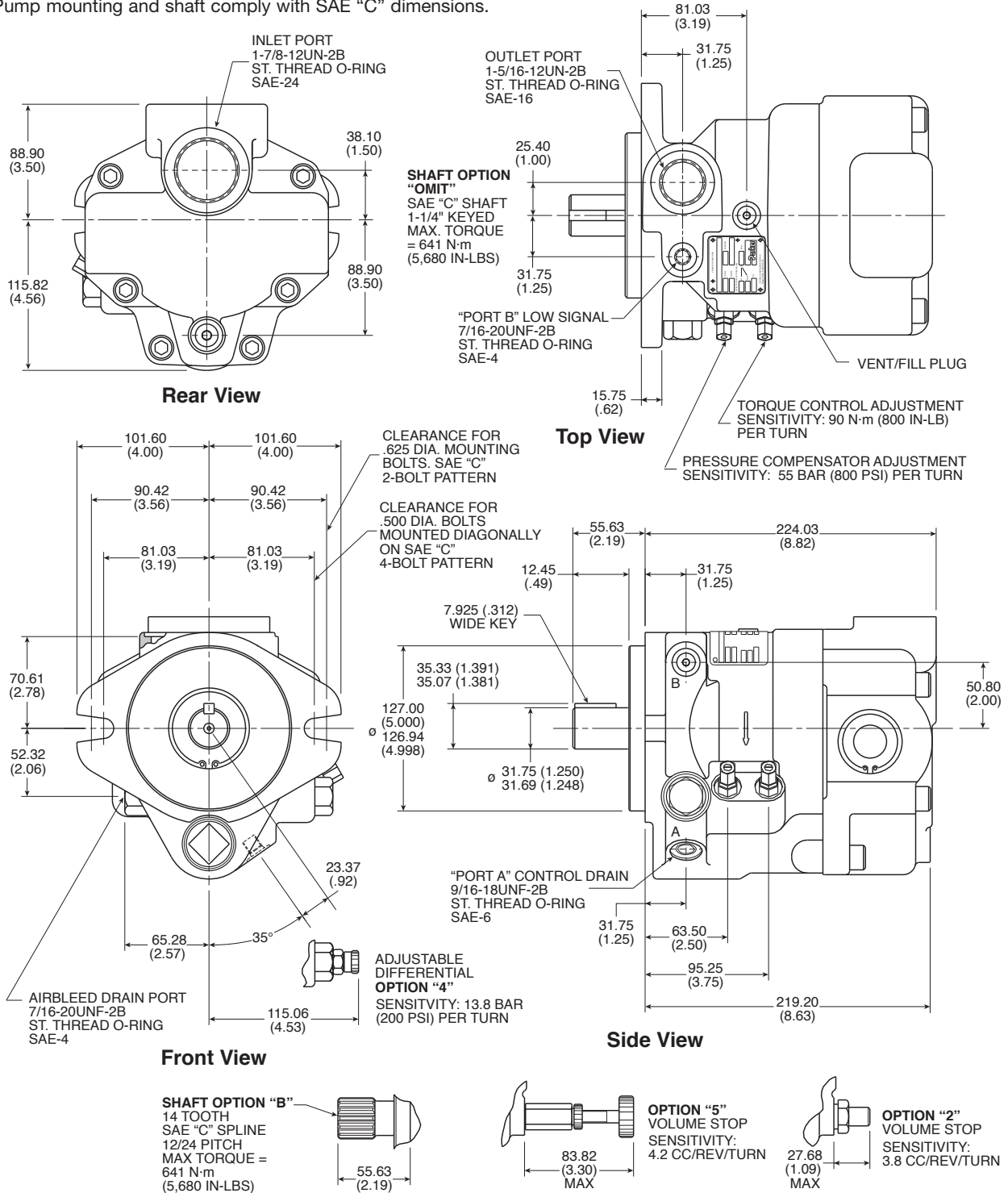

Dimensions – Top Port

* Inch equivalents for millimeter dimensions are shown in (**).

NOTES:

1. Pump shown and dimensioned is a clockwise rotation pump. Outlet port, A and B ports, and controls will be on opposite side for a counterclockwise pump.
2. Pump mounting and shaft comply with SAE "C" dimensions.

Port Location				
Option	Outlet Port	Inlet Port	Control Drain	Signal Port
2	SAE-16 Straight Thread (1-5/16-12UNC)	1-1/2 SAE 4-Bolt Flange 1/2-13UNC Threads Standard Pressure Series (Code 61)	SAE-6 Straight Thread (9/16-18UNF)	SAE-4 Straight Thread (7/16-20UNF)

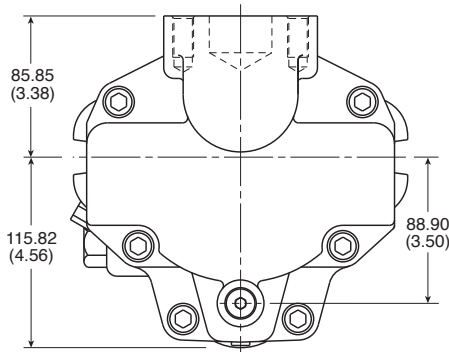

Rear View

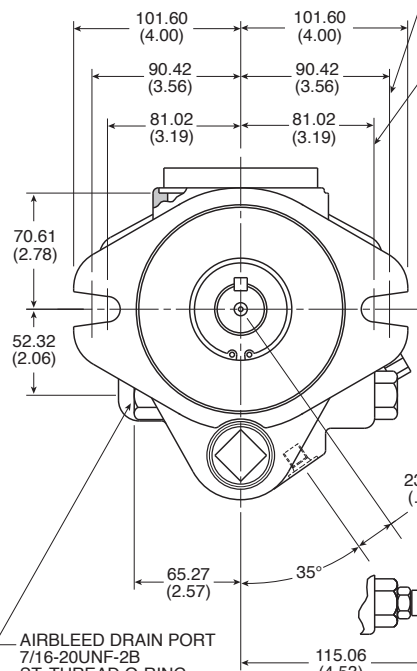

Front View

OPTION "8"
 ISO 6149-4
 ADAPTER FITTING
 ON OPTION "8"

SHAFT OPTION "B"
 14 TOOTH
 SAE "C" SPLINE
 12/24 PITCH
 MAX. TORQUE =
 641 N·m (5,680 IN-LBS)

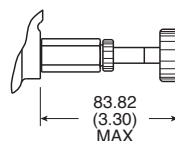
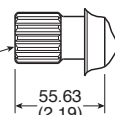

OPTION "5"
 VOLUME STOP
 SENSITIVITY:
 4.2 CC/REV/TURN

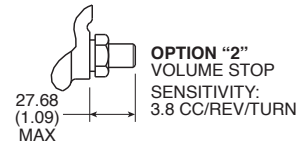

OPTION "2"
 VOLUME STOP
 SENSITIVITY:
 3.8 CC/REV/TURN

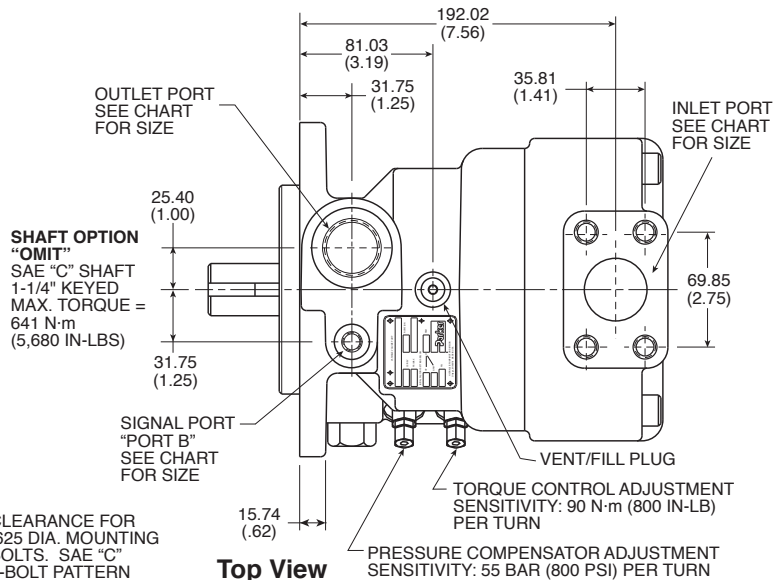

Top View

SHAFT OPTION "OMIT"
 SAE "C" SHAFT
 1-1/4" KEYED
 MAX. TORQUE =
 641 N·m
 (5,680 IN-LBS)

SIGNAL PORT "PORT B"
 SEE CHART FOR SIZE

VENT/FILL PLUG

TORQUE CONTROL ADJUSTMENT
 SENSITIVITY: 90 N·m (800 IN-LB)
 PER TURN

PRESSURE COMPENSATOR ADJUSTMENT
 SENSITIVITY: 55 BAR (800 PSI) PER TURN

CLEARANCE FOR .625 DIA. MOUNTING BOLTS. SAE "C" 2-BOLT PATTERN

CLEARANCE FOR .500 DIA. BOLTS MOUNTED DIAGONALLY ON SAE "C" 4-BOLT PATTERN

7.925 (.312) WIDE KEY

35.33 (1.391)
 35.07 (1.381)

31.75 (1.250)
 Ø 31.69 (1.248)

Ø 127.00 (5.000)
 126.94 (4.998)

CONTROL DRAIN PORT
 SEE CHART FOR SIZE

ADJUSTABLE DIFFERENTIAL OPTION "4"
 SENSITIVITY: 13.8 BAR
 (200 PSI) PER TURN

Side View

55.62 (2.19)

12.44 (.49)

31.75 (1.25)

63.50 (2.50)

95.25 (3.75)

219.20 (8.63)

224.02 (8.82)

50.80 (2.00)

31.75 (1.25)

31.75 (1.25)

31.75 (1.25)

31.75 (1.25)

31.75 (1.25)

31.75 (1.25)

31.75 (1.25)

31.75 (1.25)

31.75 (1.25)

31.75 (1.25)

31.75 (1.25)

31.75 (1.25)

31.75 (1.25)

31.75 (1.25)



Performance Information

Series PAVC100 Pressure Compensated, Variable Volume, Piston Pump

Features

- High Strength Cast-Iron Housing
- Built-In Supercharger
- High Speed Capability - 2600 RPM
- Cartridge Type Controls - Field Changeable
- Replaceable Bronze Clad Port Plate
- Airbleed Standard for Quick Priming
- Hydrodynamic Cylinder Barrel Bearing
- Full Pressure Rating on Water Glycol Fluids
- Filtered and/or Cooled Drain Line Capable 7 bar (100 PSI) Maximum
- Thru-Shaft Capable

Controls

- Pressure Compensation
- Remote Pressure Compensation
- Load Sensing
- Power (Torque) Limiting
- Power Limiting and Load Sensing
- Adjustable Maximum Volume Stop
- Low Pressure Standby

Schematic Symbol
 (Basic Pump)

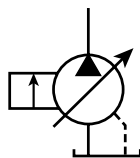

Weight and Package Size

Model	Weight In Kg (Lb)	Length From Mounting Face in CM (Inches)	Height in CM (Inches)	Height in CM (Inches)
PAVC100	50 (110)	30.73 (12.10)	24.90 (9.82)	21.59 (8.50)

Quick Reference Data Chart

Pump Model	Displacement CM ³ /REV (IN ³ /REV)	Pump Delivery @ 21 bar (300 PSI) in LPM (GPM)		*Approx. Noise Levels dB(A) @ Full Flow 1800 RPM (1200 RPM)			Input Power At 1800 RPM, Max. Displacement & 207 bar (3000 PSI)
		1200 RPM	1800 RPM	69 bar (1000 PSI)	138 bar (2000 PSI)	207 bar (3000 PSI)	
PAVC100	100 (6.1)	119.6 (31.6)	179.8 (47.5)	82 (78)	82 (79)	85 (80)	71.2 kw (95.5 hp)

* Since many variables such as mounting, tank style, plant layout, etc., effect noise levels, it cannot be assumed that the above readings will be equal to those in the field. The above values are for guidance in selecting the proper pump. Noise levels are A-weighted, mean sound pressure levels at 1 meter from the pump, measured and recorded in accordance with applicable ISO and NFPA standards.

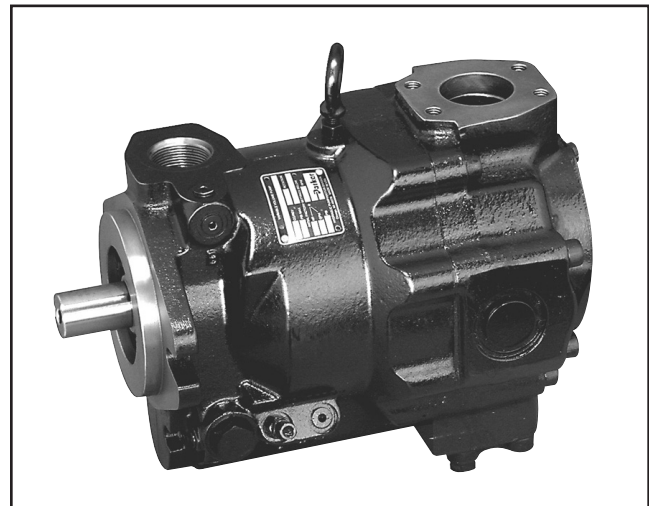

Specifications

Pressure Ratings:

Outlet Port: 207 bar (3000 PSI) Continuous (P1)
 248 bar (3600 PSI) Peak (P3)

Inlet Port: 1.7 bar (25 PSI) Maximum
 0.17 bar (5 In. Hg.) Minimum @ 1800 RPM (See Inlet Chart for other speeds)

Control Drain: 7 bar (100 PSI) Maximum

Speed Ratings: 600 to 2600 RPM

Operating Temperature Range: - 40°C to 71°C
 (- 40°F to 160°F)

Housing Material: Cast-Iron

Filtration: Maintain SAE Class 4, ISO 16/13, ISO 18/15 Maximum Recommended

Mounting: SAE C 2-Bolt Flange Mount or Diagonally on SAE C 4-Bolt Flange Mount

Installation Data: See page A46 of this catalog for specific recommendations pertaining to system cleanliness, fluids, start-up, inlet conditions, shaft alignment, drain line restrictions and other important factors relative to the proper installation and use of these pumps.

Typical Performance Data - Fluid: Standard Hydraulic Oil 100 SSU @ 49°C (120°F)

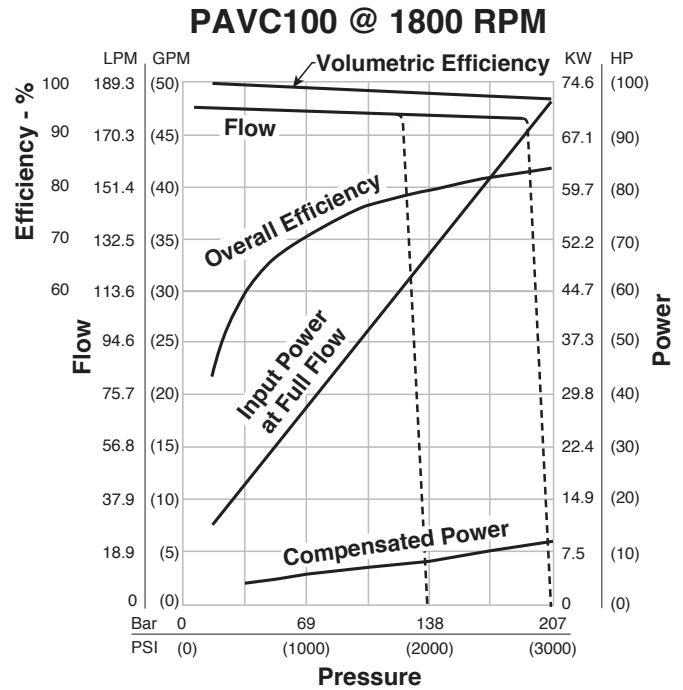
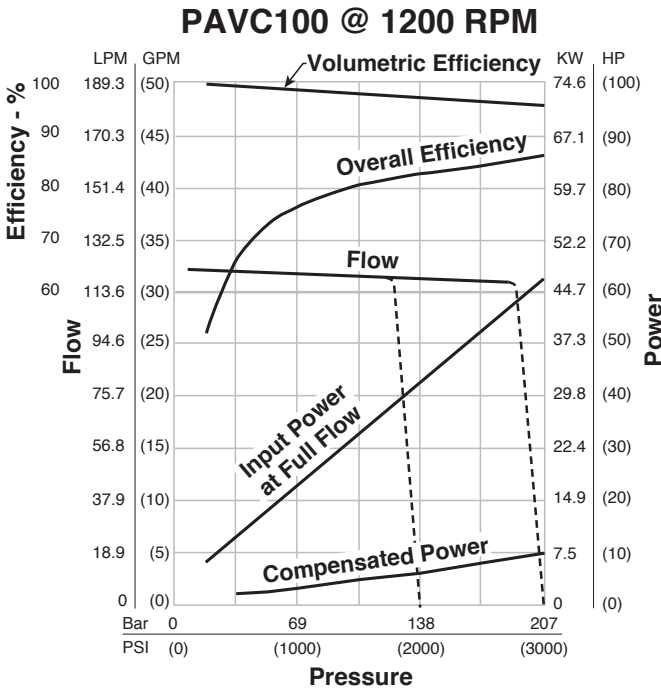

NOTE: The efficiencies and data in the graph are good only for pumps running at 1800 RPM and stroked to maximum. To calculate approximate input power for the other conditions, use the following formula:

$$HP = \left[\frac{Q \times (PSI)}{1714} \right] + (CHp)$$

WHERE:

- Q = Actual Output Flow in GPM
- PSI = Pressure At Pump Outlet
- CHp = Input Power @ Full Compensation @ 1800 RPM (from graph read at operating pressure)

Actual GPM is directly proportional to drive speed and maximum volume setting. Flow loss, however, is a function of pressure only.

**PAVC100
 Inlet Characteristics at Full Displacement
 (Graph only valid at sea level)**

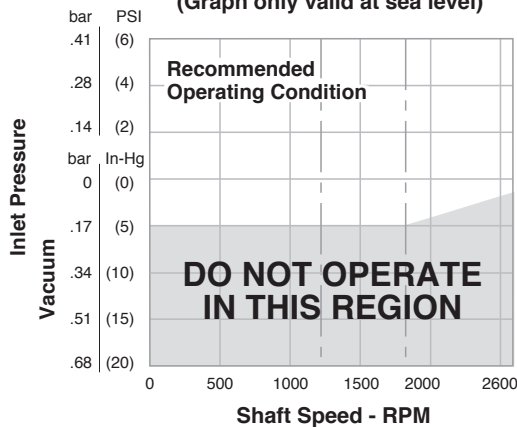

**Compensated Control
 Drain Flow @ 1800 RPM**

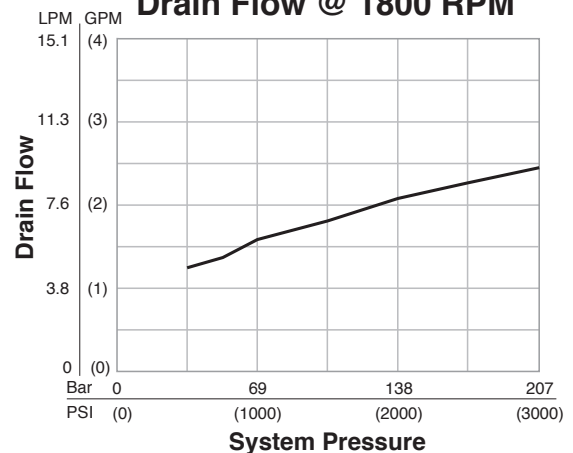

Typical Performance Data

**Minimum Power Settings Attainable
 With Control Options C, H, CM & HM**

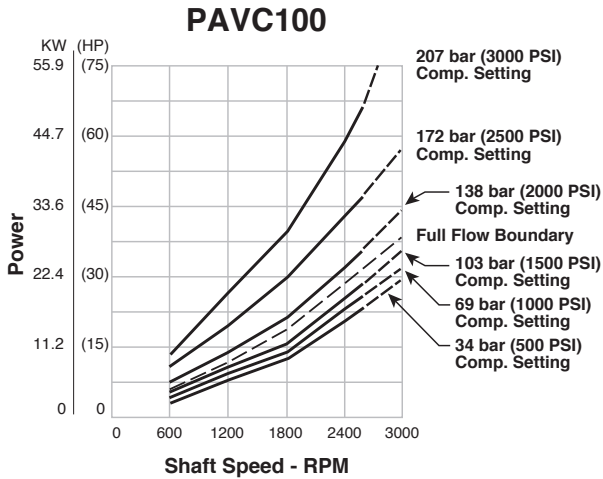

NOTE: Minimum attainable HP setting means that input power will not exceed the indicated setting at the indicated RPM and that the pump will achieve full compensator pressure selected. If setting input power limiter below full flow boundary, full flow may not be obtained at low operating pressure. Determine maximum input power limitation at desired RPM. All points above desired compensator setting curve can be achieved.

Power (Torque) Limiting Curves

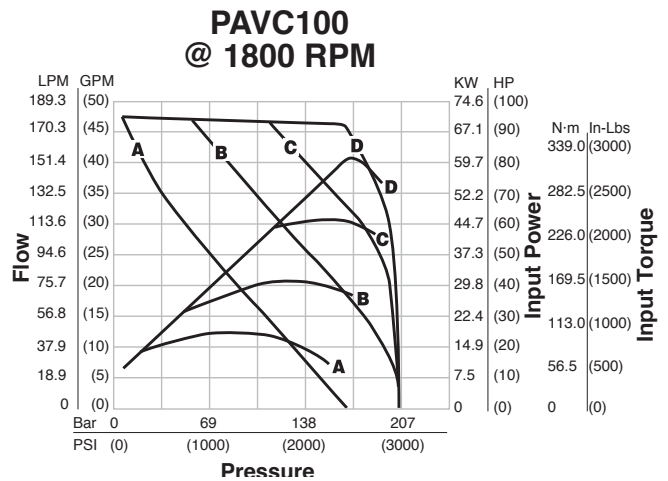
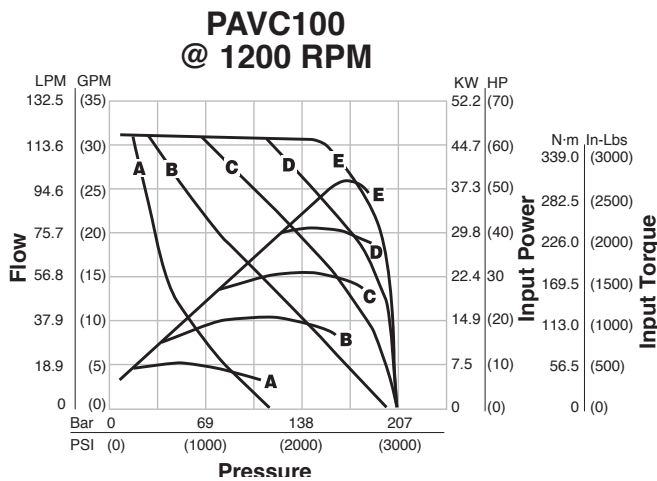

See page 12 for "How to Read Curves" information.



Rear Ported Pump Dimensions

* Inch equivalents for millimeter dimensions are shown in (**).

NOTE:

Pump shown and dimensioned is a clockwise rotation pump. For a counterclockwise rotation pump the outlet port, control drain, signal port and pump controls will be on other side.

Port Location					
Outlet Option	Inlet Option	Outlet Port	Inlet Port	Control Drain	Signal Port
Omit	Omit	SAE-20 Straight Thread (1-5/8-12UNC)	2" SAE 4-Bolt Flange 1/2-13UNC Threads Standard Pressure Series (Code 61)	SAE-6 Straight Thread (9/16-18UNF)	SAE-4 Straight Thread (7/16-20UNF)
3	Omit	1-1/4" SAE Flange 7/16-14UNC Thread Standard Pressure Series (Code 61)	2" SAE 4-Bolt Flange 1/2-13UNC Threads Standard Pressure Series (Code 61)	SAE-6 Straight Thread (9/16-18UNF)	SAE-4 Straight Thread (7/16-20UNF)

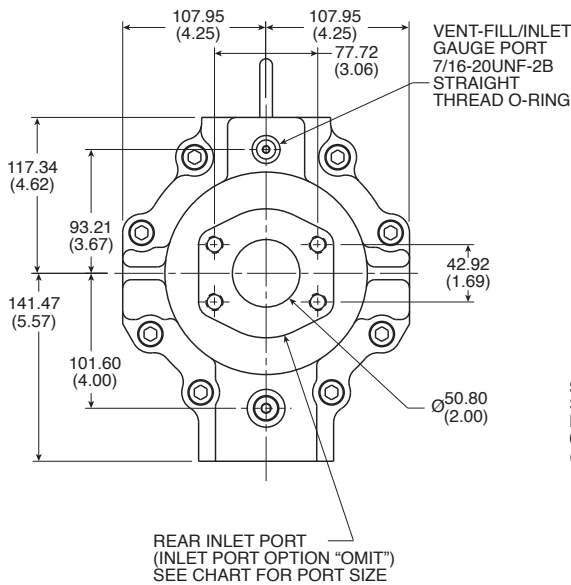
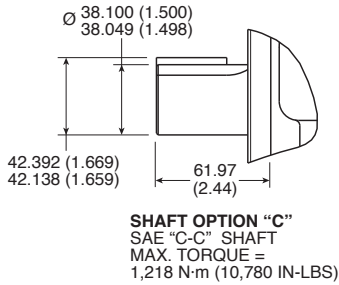
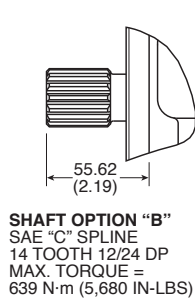

Rear View

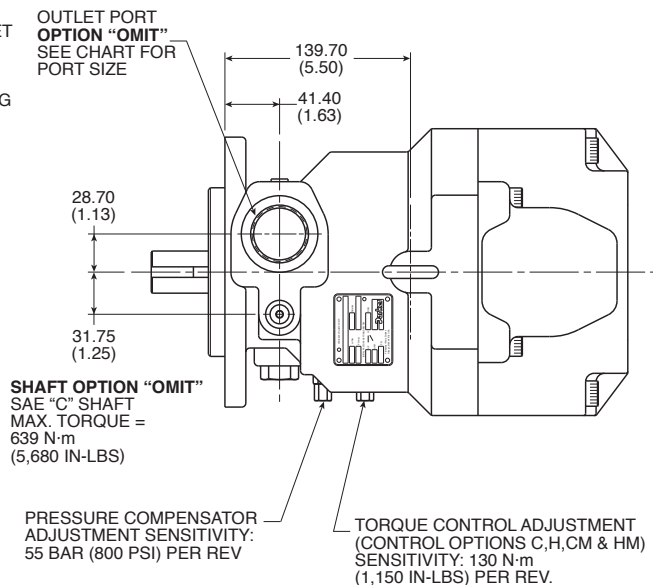

Top View

Rear Ported Pump Dimensions

* Inch equivalents for millimeter dimensions are shown in (**).

NOTE:

Pump shown and dimensioned is a clockwise rotation pump. For a counterclockwise rotation pump the outlet port, control drain, signal port and pump controls will be on other side.

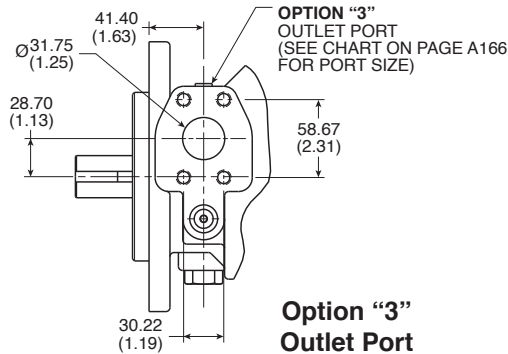

**Option "3"
 Outlet Port**

ADAPTABLE TO SAE "C" 2-BOLT MOUNTING OR DIAGONALLY ON SAE "C" 4-BOLT MOUNTING

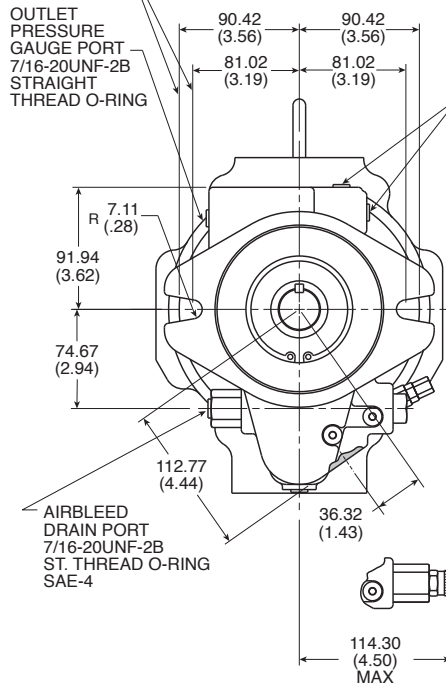

Front View

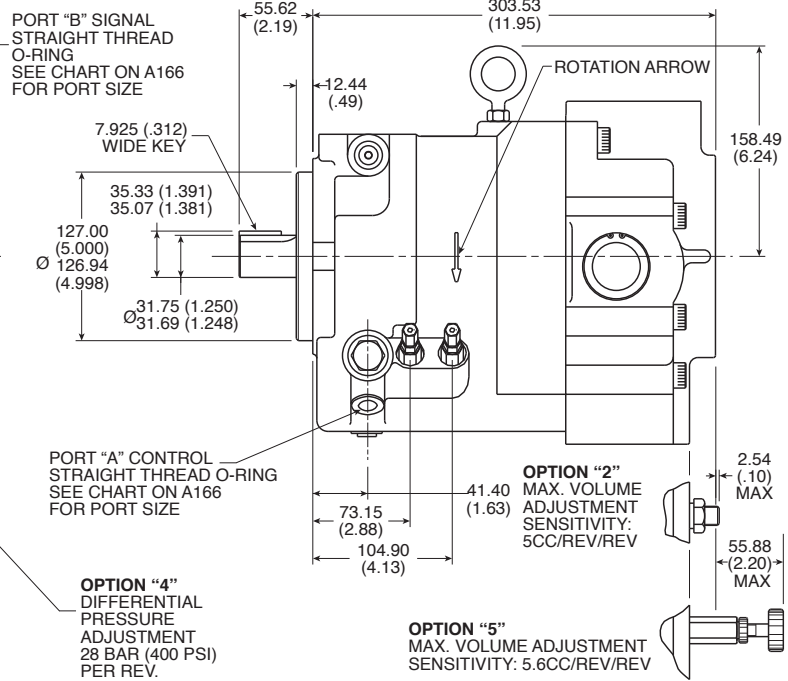

Side View



Top/Bottom Ported Pump Dimensions

* Inch equivalents for millimeter dimensions are shown in (**).

NOTES:

1. Pump shown and dimensioned is a clockwise rotation top/bottom inlet option pump. For a counterclockwise rotation pump the outlet port, control drain, signal port, and pump controls will be on other side.
2. For other available shafts see page A34.

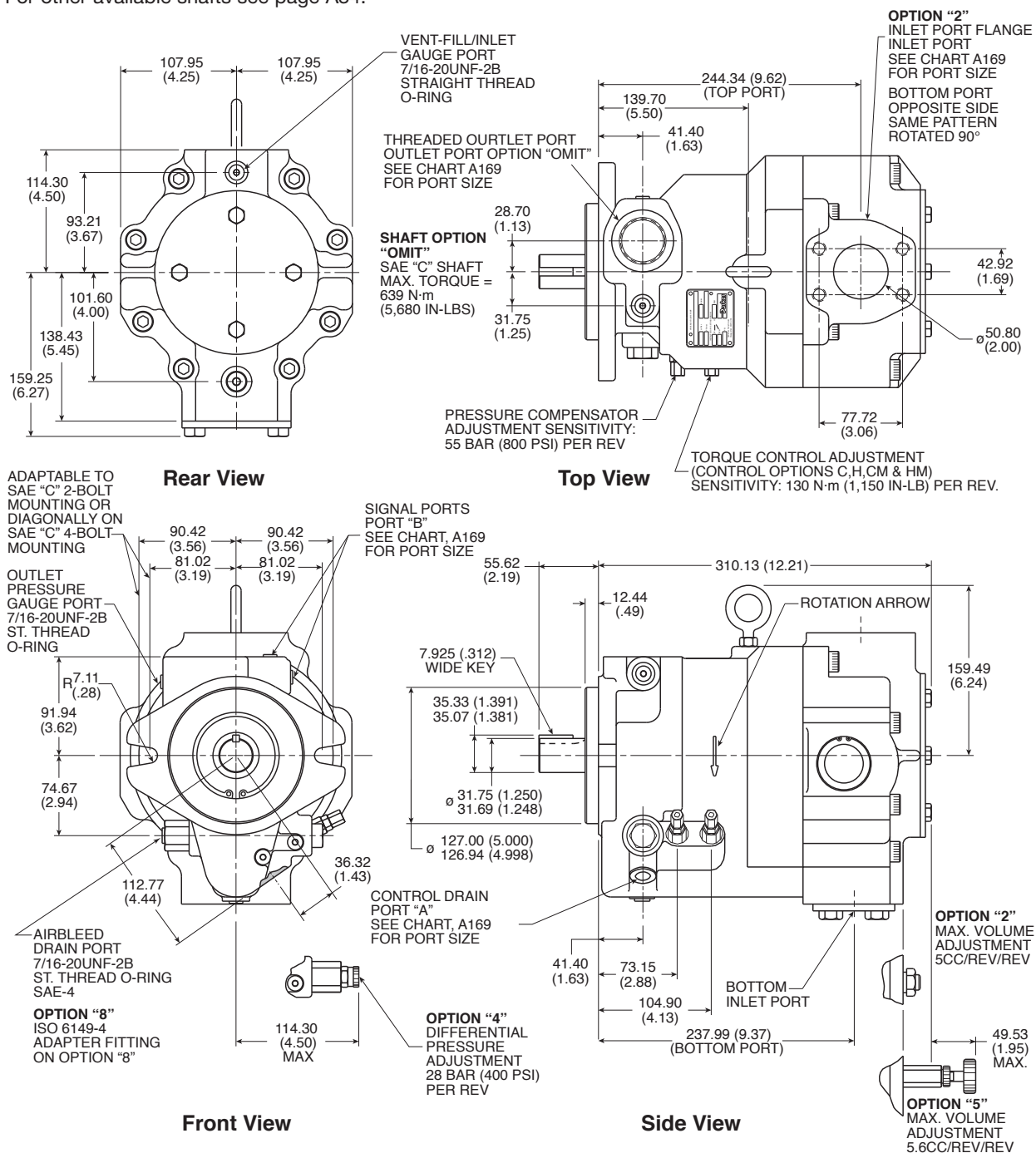

Top/Bottom Ported Pump Dimensions

* Inch equivalents for millimeter dimensions are shown in (**).

NOTE:

Pump shown and dimensioned is a clockwise rotation pump. For a counterclockwise rotation pump the outlet port, control drain, signal port and pump controls will be on other side.

Port Location					
Outlet Option	Inlet Option	Outlet Port	Inlet Port	Control Drain	Signal Port
Omit	2	SAE-20 Straight Thread (1-5/8-12UN)	2" SAE 4-Bolt Flange 1/2-13UNC Threads Standard Pressure Series (Code 61)	SAE-6 Straight Thread (9/16-18UNF)	SAE-4 Straight Thread (7/16-20UNF)
3	2	1-1/4" SAE Flange 7/16-14UNC Thread Standard Pressure Series (Code 61)	2" SAE 4-Bolt Flange 1/2-13UNC Threads Standard Pressure Series (Code 61)	SAE-6 Straight Thread (9/16-18UNF)	SAE-4 Straight Thread (7/16-20UNF)

Dimensions – Thru-Shaft Options

* Inch equivalents for millimeter dimensions are shown in (**).

Variation	A	B	C	D	E	F	G	H
6A4	—	Ø 82.58/82.60 (3.251/3.252)	106.38 (4.188)	N/A	3/8-16UNC-2B	N/A	9 Tooth 16/32 Pitch	N/A
6B3	53.98 (2.125)	Ø 101.63/101.65 (4.001/4.002)	146.05 (5.750)	89.81 (3.536)	1/2-13UNC-2B	1/2-13UNC-2B	13 Tooth 16/32 Pitch	N/A
6C3	53.98 (2.125)	Ø 127.03/127.05 (5.001/5.002)	180.98 (7.125)	114.50 (4.508)	5/8-11UNC-2B	1/2-13UNC-2B	14 Tooth 12/24 Pitch	N/A

Thru-Shaft Options – Dimensions

* Inch equivalents for millimeter dimensions are shown in (**).

NOTES:

1. Rear adapters may be rotated 90°.
2. Pump shown is a clockwise rotation pump. For a counterclockwise pump the outlet port, control drain and control adjustments will be on opposite side.
3. Maximum torque transmitting capacity for rear mounting of pumps is 639 N•m (5,680 In. Lbs). Lower allowables may apply based on pump mounted on rear.

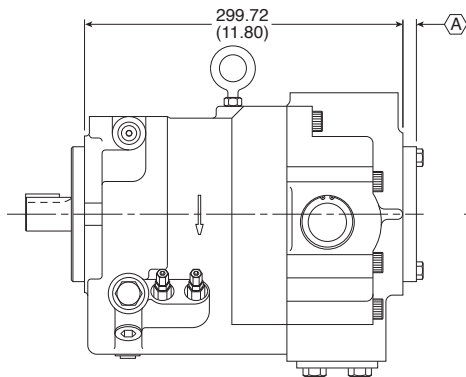

Side View

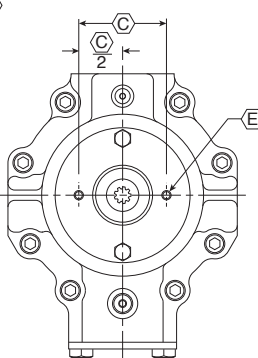

Rear View

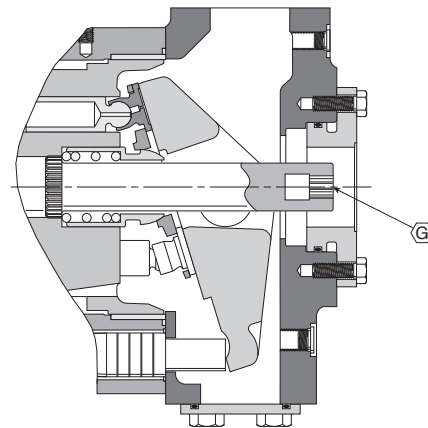

Variations 6A* & 9A*

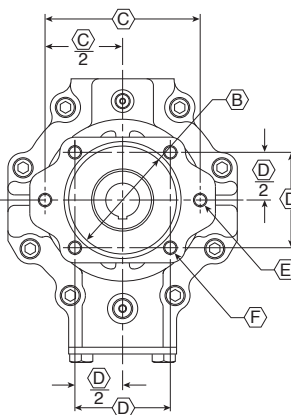

Rear View

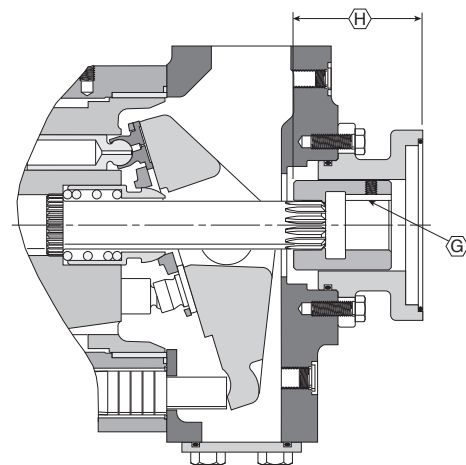

**Variations 6B* & 6C*
 9B* & 9C***

Generic Pump Assembly

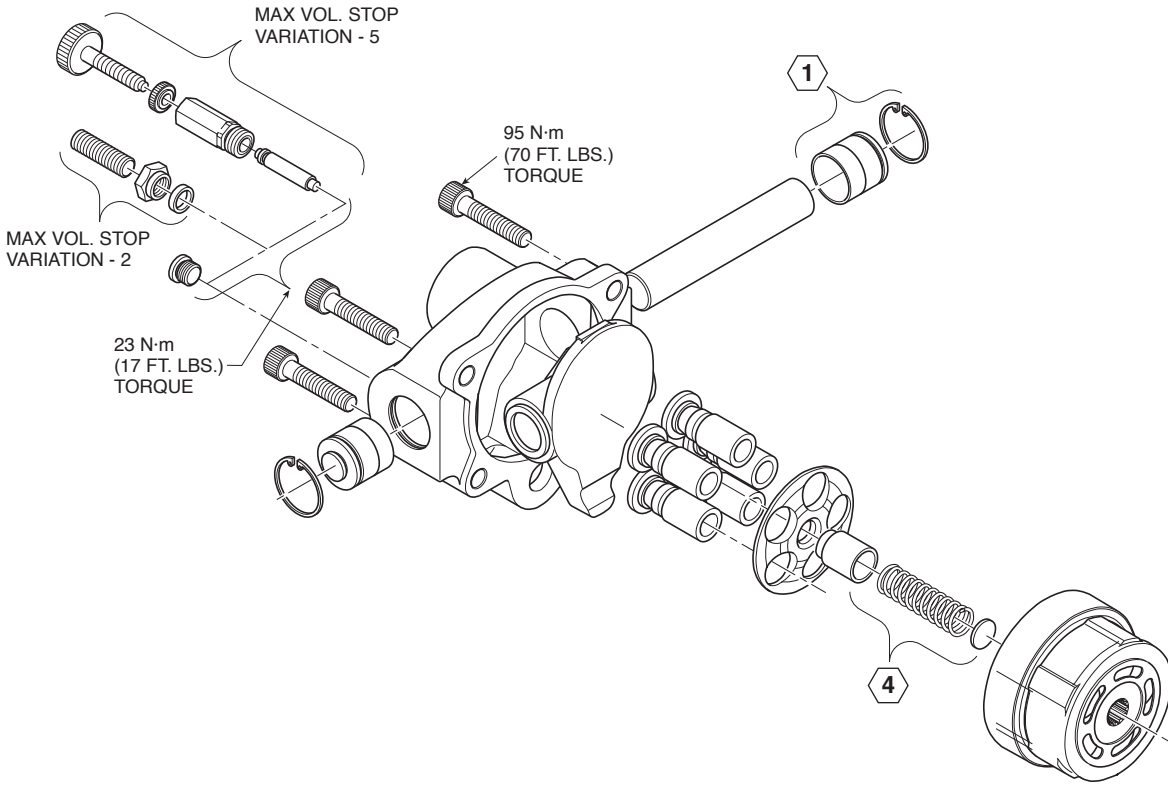

<p>1 TRUNNION CAP ASSEMBLY</p> <p>THRUST WASHER (Not on PAVC100) SNAP RING O-RING TRUNNION CAP ROLLER BEARING</p>	<p>4 RETAINER DETAIL</p>	<p>7 AIR BLEED ASSEMBLY</p> <p>BODY SPRING BALL STAKE BALL IN PLACE</p>
<p>2 SLEEVE ASSEMBLY</p> <p>SLEEVE O-RING 1 BACK-UP RING 2</p>	<p>5 BEARING SHAFT ASSEMBLY</p>	<p>8 ADJUSTING STEM ASSEMBLY</p> <p>PLUG STEM O-RING 1 BACK-UP RING 2</p>
<p>3 PLUG ASSEMBLY</p> <p>SLEEVE O-RING 1 BACK-UP RING 2</p>	<p>6 PISTON - DIFFERENTIAL CONTROL</p> <p>PISTON BODY O-RING 1 BACK-UP RING 2</p>	<p>9 PORT PLATE</p> <p>LEFT HAND (CCW) PORT PLATE SHOWN IN ASSEMBLY (ABOVE). RIGHT HAND (CW) PORT PLATE SHOWN BELOW.</p>



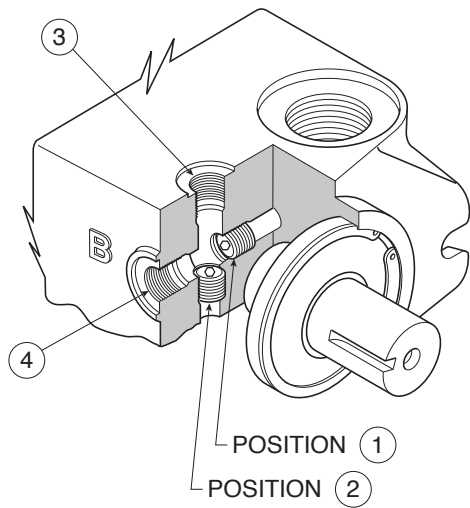
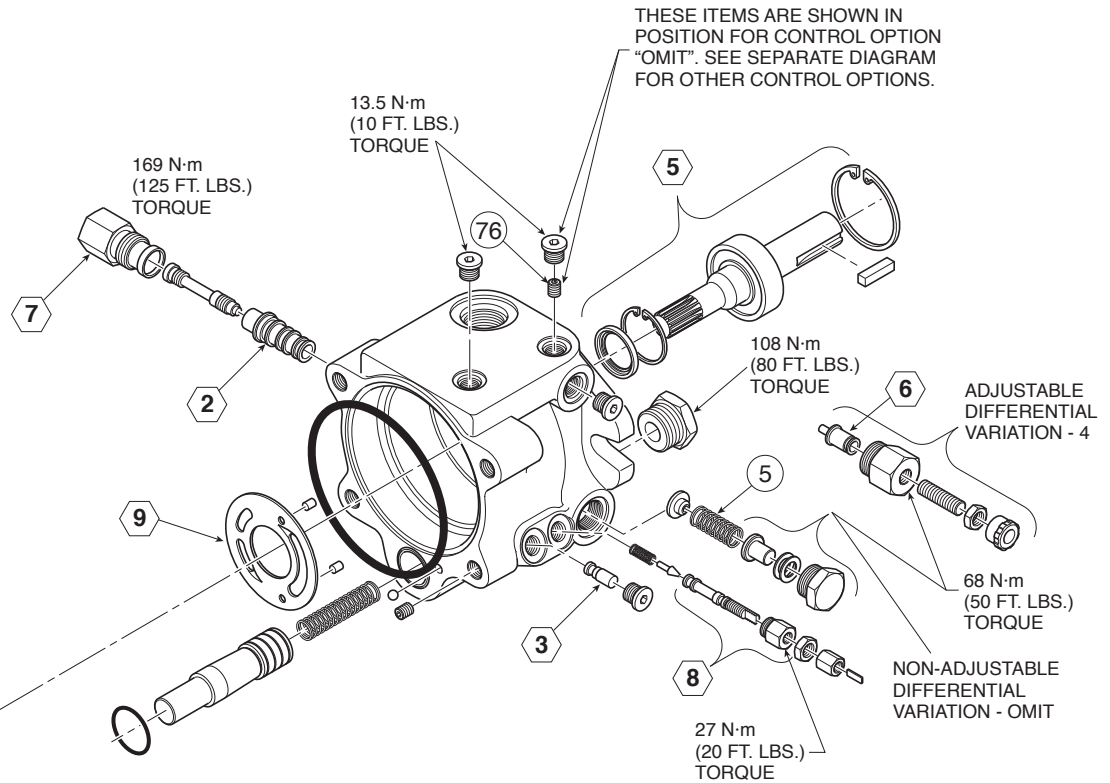

10 TORQUE (HP) CONTROL (See next page)

Part Number Description

102 x 1	Solid Pipe Plug (1/16")
108 x 4	SAE Plug - 4
690870	.028 Orifice Plug (1/16")
800599	.034 Orifice Plug (1/16")
786635	.034 Orifice Fitting
787474	Upstroke Spring

PAVC 33, 38, 65

Control Option	Position				
	1	2	3	4	5
Omit	Open	800599	108 x 4	108 x 4	Omit
A	102 x 1	800599	Open	108 x 4	787474*
C	102 x 1	800599	Open	108 x 4	787474*
H	Open	800599	108 x 4	108 x 4	Omit
M	800599	Open	Open	108 x 4	Omit
ME	102 x 1	800599	Open	108 x 4	787474*
S	800599	Open	Open	108 x 4	Omit
SE	102 x 1	800599	Open	108 x 4	Omit
AM	102 x 1	800599	786635	Open	787474*
CM	102 x 1	800599	786635	Open	787474*
HM	800599	Open	Open	108 x 4	Omit

* Available Only on PAVC65.

PAVC 100

Control Option	Position				
	1	2	3	4	5 †
Omit	Open	690870	108 x 4	108 x 4	787474
A	102 x 1	690870	Open	108 x 4	787474
C	102 x 1	690870	Open	108 x 4	787474
H	Open	690870	108 x 4	108 x 4	787474
M	690870	Open	Open	108 x 4	787474
ME	102 x 1	690870	Open	108 x 4	787474
S	690870	Open	Open	108 x 4	787474
SE	102 x 1	690870	Open	108 x 4	787474
AM	102 x 1	690870	786635	Open	787474
CM	102 x 1	690870	786635	Open	787474
HM	690870	Open	Open	108 x 4	787474

† 787474 is always included with the PAVC100.

**10 CONTROL OPTION "C" & "H"
PRESSURE, POWER & FLOW**

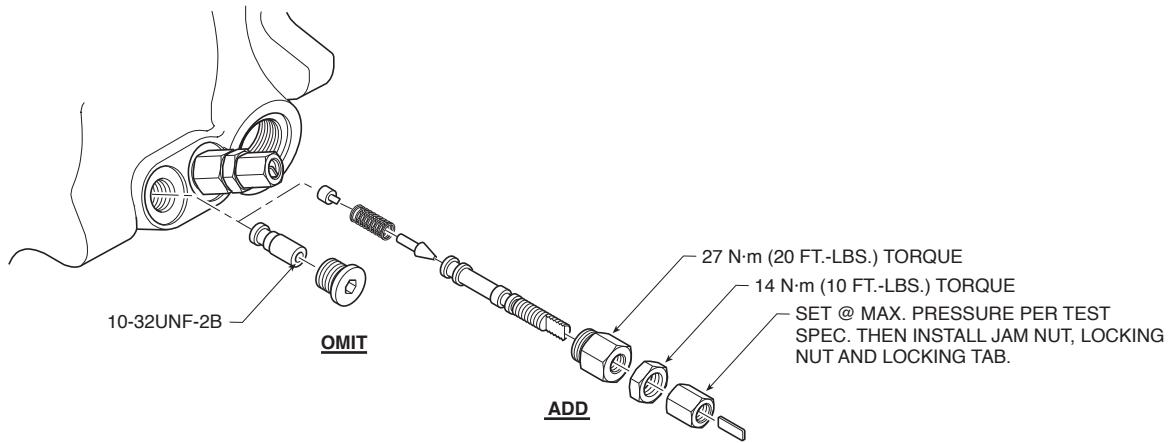

Use Of A Relief Valve

The use of a relief valve, while not mandatory is recommended in the main circuit to suppress hydraulic shock loads and additional system protection. If a minimum volume stop is used, the use of a relief valve is mandatory.

Fluid Recommendations

Premium quality hydraulic oil with a viscosity range between 150-250 SSU (30-50 cst.) at 38°C (100°F). Normal operating viscosity range between 80-1000 SSU (17-180 cst.). Maximum start-up viscosity is 4000 SSU (1000 cst.).

NOTE: Consult Parker when exceeding 71°C (160°F) operation. Oil should have maximum anti-wear properties, rust and oxidation treatment.

Filtration

For maximum pump and system component life, the system should be protected from contamination at a level not to exceed 125 particles greater than 10 microns per milliliter of fluid. (SAE Class 4/ISO 16/13). Due to the nature of variable displacement pumps, variations in pump inlet conditions, fluid acceleration losses, system aeration, and duty cycle we do not recommend suction line filters. We do recommend the use of a properly sized, in-tank suction strainer. Contact your Parker representative for assistance.

Start-Up

On initial start-up, the case should be filled with oil, pressure should be reduced and the circuit should be open or the air bled from the pump outlet to permit priming. Use of the airbleed is recommended on initial start-up. See Installation and Mounting Section to connect airbleed.

Inlet Conditions

Not to exceed .17 bar (5 In. Hg.). Vacuum at 1800 RPM on petroleum base fluids. See recommended speed spectrum for specific inlet conditions.

Shaft Rotation and Line Up

Pump and motor shaft alignment must be within .010 TIR maximum, using a standard floating coupling. Please follow coupling manufacturer's recommended installation instructions to prevent end thrust on pump shaft. Turn pump to assure freedom of rotation. Pump and motor must be on a rigid base.

The coupling should be sized to absorb the peak

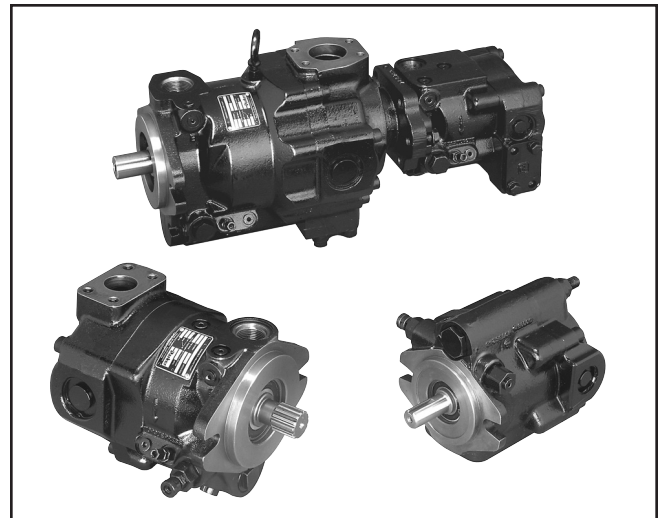

horsepower developed.

Installation and Mounting

When a PAVC Series Pump is mounted above the fluid level, the position of the "control drain" is not restricted but **the inlet port should not be on the bottom (PAVC100)**. When a PAVC Series Pump is mounted below the fluid level the position of all ports are not restricted. The "control drain" should be a separate line to the reservoir and extend below the oil level as far from the inlet line as possible. The "control drain" line can be filtered and/or cooled (must not exceed 7 bar (100 PSI) back pressure). Suggested maximum line length is 10 feet.

A built in airbleed is standard on all PAVC 33, 38, 65 and 100 Pumps. To connect, remove airbleed drain plug and connect a line unrestricted to reservoir extending below minimum oil level. Back pressure in this line must not exceed .28 bar (4 PSI).

Special Installations

Consult your Parker representative for any application requiring the following:

Pressure above rated, drive speed above maximum, indirect drive, fluid other than petroleum oil, oil temperature above 71°C (160°F).

Inlet Pressure

Not to exceed 1.72 bar (25 PSI).

The items described in this document and other documents and descriptions provided by Parker Hannifin Corporation, Hydraulics Group, and its authorized distributors ("Seller") are hereby offered for sale at prices to be established by Seller. This offer and its acceptance by any customer ("Buyer") shall be governed by all of the following Terms and Conditions. Buyer's order for any item described in its document, when communicated to Seller verbally, or in writing, shall constitute acceptance of this offer. All goods or work described will be

referred to as "Products".

1. Terms and Conditions. Seller's willingness to offer Products, or accept an order for Products, to or from Buyer is expressly conditioned on Buyer's assent to these Terms and Conditions and to the terms and conditions found on-line at www.parker.com/saleterms/. Seller objects to any contrary or additional term or condition of Buyer's order or any other document issued by Buyer.

2. Price Adjustments; Payments. Prices stated on the reverse side or preceding pages of this document are valid for 30 days. After 30 days, Seller may change prices to reflect any increase in its costs resulting from state, federal or local legislation, price increases from its suppliers, or any change in the rate, charge, or classification of any carrier. The prices stated on the reverse or preceding pages of this document do not include any sales, use, or other taxes unless so stated specifically. Unless otherwise specified by Seller, all prices are F.O.B. Seller's facility, and payment is due 30 days from the date of invoice. After 30 days, Buyer shall pay interest on any unpaid invoices at the rate of 1.5% per month or the maximum allowable rate under applicable law.

3. Delivery Dates; Title and Risk; Shipment. All delivery dates are approximate and Seller shall not be responsible for any damages resulting from any delay. Regardless of the manner of shipment, title to any products and risk of loss or damage shall pass to Buyer upon tender to the carrier at Seller's facility (i.e., when it's on the truck, it's yours). Unless otherwise stated, Seller may exercise its judgment in choosing the carrier and means of delivery. No deferment of shipment at Buyers' request beyond the respective dates indicated will be made except on terms that will indemnify, defend and hold Seller harmless against all loss and additional expense. Buyer shall be responsible for any additional shipping charges incurred by Seller due to Buyer's changes in shipping, product specifications or in accordance with Section 13, herein.

4. Warranty. Seller warrants that the Products sold hereunder shall be free from defects in material or workmanship for a period of eighteen months from the date of delivery to Buyer. The prices charged for Seller's products are based upon the exclusive limited warranty stated above, and upon the following disclaimer: **DISCLAIMER OF WARRANTY: THIS WARRANTY COMPRISES THE SOLE AND ENTIRE WARRANTY PERTAINING TO PRODUCTS PROVIDED HEREUNDER. SELLER DISCLAIMS ALL OTHER WARRANTIES, EXPRESS AND IMPLIED, INCLUDING MERCHANTABILITY AND FITNESS FOR A PARTICULAR PURPOSE.**

5. Claims; Commencement of Actions. Buyer shall promptly inspect all Products upon delivery. No claims for shortages will be allowed unless reported to the Seller within 10 days of delivery. No other claims against Seller will be allowed unless asserted in writing within 60 days after delivery or, in the case of an alleged breach of warranty, within 30 days after the date within the warranty period on which the defect is or should have been discovered by Buyer. Any action based upon breach of this agreement or upon any other claim arising out of this sale (other than an action by Seller for any amount due to Seller from Buyer) must be commenced within thirteen months from the date of tender of delivery by Seller or, for a cause of action based upon an alleged breach of warranty, within thirteen months from the date within the warranty period on which the defect is or should have been discovered by Buyer.

6. LIMITATION OF LIABILITY. UPON NOTIFICATION, SELLER WILL, AT ITS OPTION, REPAIR OR REPLACE A DEFECTIVE PRODUCT, OR REFUND THE PURCHASE PRICE. IN NO EVENT SHALL SELLER BE LIABLE TO BUYER FOR ANY SPECIAL, INDIRECT, INCIDENTAL OR CONSEQUENTIAL DAMAGES ARISING OUT OF, OR AS THE RESULT OF, THE SALE, DELIVERY, NON-DELIVERY, SERVICING, USE OR LOSS OF USE OF THE PRODUCTS OR ANY PART THEREOF, OR FOR ANY CHARGES OR EXPENSES OF ANY NATURE INCURRED WITHOUT SELLER'S WRITTEN CONSENT, EVEN IF SELLER HAS BEEN NEGLIGENT, WHETHER IN CONTRACT, TORT OR OTHER LEGAL THEORY. IN NO EVENT SHALL SELLER'S LIABILITY UNDER ANY CLAIM MADE BY BUYER EXCEED THE PURCHASE PRICE OF THE PRODUCTS.

7. Contingencies. Seller shall not be liable for any default or delay in performance if caused by circumstances beyond the reasonable control of Seller.

8. User Responsibility. The user, through its own analysis and testing, is solely responsible for making the final selection of the system and Product and assuring that all performance, endurance, maintenance, safety and warning requirements of the application are met. The user must analyze all aspects of the application and follow applicable industry standards and Product information. If Seller provides Product or system options, the user is responsible for determining that such data and specifications are suitable and sufficient for all applications and reasonably foreseeable uses of the Products or systems.

9. Loss to Buyer's Property. Any designs, tools, patterns, materials, drawings, confidential information or equipment furnished by Buyer or any other items which become Buyer's property, may be considered obsolete and may be destroyed by Seller after two consecutive years have elapsed without Buyer placing an order for the items which are manufactured using such property. Seller shall not be responsible for any loss or damage to such property while it is in Seller's possession or control.

10. Special Tooling. A tooling charge may be imposed for any special tooling, including without limitation, dies, fixtures, molds and patterns, acquired to manufacture Products. Such special tooling shall be and remain Seller's property notwithstanding payment of any charges by Buyer. In no event will Buyer acquire any interest in apparatus belonging to Seller which is utilized in the manufacture of the Products, even if such apparatus has been specially converted or adapted for such manufacture and notwithstanding any charges paid by Buyer. Unless otherwise agreed, Seller shall have the right to alter, discard or

otherwise dispose of any special tooling or other property in its sole discretion at any time.

11. Buyer's Obligation; Rights of Seller. To secure payment of all sums due or otherwise, Seller shall retain a security interest in the goods delivered and this agreement shall be deemed a Security Agreement under the Uniform Commercial Code. Buyer authorizes Seller as its attorney to execute and file on Buyer's behalf all documents Seller deems necessary to perfect its security interest. Seller shall have a security interest in, and lien upon, any property of Buyer in Seller's possession as security for the payment of any amounts owed to Seller by Buyer.

12. Improper Use and Indemnity. Buyer shall indemnify, defend, and hold Seller harmless from any claim, liability, damages, lawsuits, and costs (including attorney fees), whether for personal injury, property damage, patent, trademark or copyright infringement or any other claim, brought by or incurred by Buyer, Buyer's employees, or any other person, arising out of: (a) improper selection, improper application or other misuse of Products purchased by Buyer from Seller; (b) any act or omission, negligent or otherwise, of Buyer; (c) Seller's use of patterns, plans, drawings, or specifications furnished by Buyer to manufacture Product; or (d) Buyer's failure to comply with these terms and conditions. Seller shall not indemnify Buyer under any circumstance except as otherwise provided.

13. Cancellations and Changes. Orders shall not be subject to cancellation or change by Buyer for any reason, except with Seller's written consent and upon terms that will indemnify, defend and hold Seller harmless against all direct, incidental and consequential loss or damage. Seller may change product features, specifications, designs and availability with notice to Buyer.

14. Limitation on Assignment. Buyer may not assign its rights or obligations under this agreement without the prior written consent of Seller.

15. Entire Agreement. This agreement contains the entire agreement between the Buyer and Seller and constitutes the final, complete and exclusive expression of the terms of the agreement. All prior or contemporaneous written or oral agreements or negotiations with respect to the subject matter are herein merged.

16. Waiver and Severability. Failure to enforce any provision of this agreement will not waive that provision nor will any such failure prejudice Seller's right to enforce that provision in the future. Invalidation of any provision of this agreement by legislation or other rule of law shall not invalidate any other provision herein. The remaining provisions of this agreement will remain in full force and effect.

17. Termination. This agreement may be terminated by Seller for any reason and at any time by giving Buyer thirty (30) days written notice of termination. In addition, Seller may by written notice immediately terminate this agreement for the following: (a) Buyer commits a breach of any provision of this agreement (b) the appointment of a trustee, receiver or custodian for all or any part of Buyer's property (c) the filing of a petition for relief in bankruptcy of the other Party on its own behalf, or by a third party (d) an assignment for the benefit of creditors, or (e) the dissolution or liquidation of the Buyer.

18. Governing Law. This agreement and the sale and delivery of all Products hereunder shall be deemed to have taken place in and shall be governed and construed in accordance with the laws of the State of Ohio, as applicable to contracts executed and wholly performed therein and without regard to conflicts of laws principles. Buyer irrevocably agrees and consents to the exclusive jurisdiction and venue of the courts of Cuyahoga County, Ohio with respect to any dispute, controversy or claim arising out of or relating to this agreement. Disputes between the parties shall not be settled by arbitration unless, after a dispute has arisen, both parties expressly agree in writing to arbitrate the dispute.

19. Indemnity for Infringement of Intellectual Property Rights. Seller shall have no liability for infringement of any patents, trademarks, copyrights, trade dress, trade secrets or similar rights except as provided in this Section. Seller will defend and indemnify Buyer against allegations of infringement of U.S. patents, U.S. trademarks, copyrights, trade dress and trade secrets ("Intellectual Property Rights"). Seller will defend at its expense and will pay the cost of any settlement or damages awarded in an action brought against Buyer based on an allegation that a Product sold pursuant to this Agreement infringes the Intellectual Property Rights of a third party. Seller's obligation to defend and indemnify Buyer is contingent on Buyer notifying Seller within ten (10) days after Buyer becomes aware of such allegations of infringement, and Seller having sole control over the defense of any allegations or actions including all negotiations for settlement or compromise. If a Product is subject to a claim that it infringes the Intellectual Property Rights of a third party, Seller may, at its sole expense and option, procure for Buyer the right to continue using the Product, replace or modify the Product so as to make it noninfringing, or offer to accept return of the Product and return the purchase price less a reasonable allowance for depreciation. Notwithstanding the foregoing, Seller shall have no liability for claims of infringement based on information provided by Buyer, or directed to Products delivered hereunder for which the designs are specified in whole or part by Buyer, or infringements resulting from the modification, combination or use in a system of any Product sold hereunder. The foregoing provisions of this Section shall constitute Seller's sole and exclusive liability and Buyer's sole and exclusive remedy for infringement of Intellectual Property Rights.

20. Taxes. Unless otherwise indicated, all prices and charges are exclusive of excise, sales, use, property, occupational or like taxes which may be imposed by any taxing authority upon the manufacture, sale or delivery of Products.

21. Equal Opportunity Clause. For the performance of government contracts and where dollar value of the Products exceed \$10,000, the equal employment opportunity clauses in Executive Order 11246, VEVRAA, and 41 C.F.R. §§ 60-1.4(a), 60-741.5(a), and 60-250.4, are hereby incorporated.

North America

Industrial

USA

Chicago Region

Naperville, IL
Tel: (630) 964 0796

Great Lakes Region

Fairlawn, OH
Tel: (330) 670 2680

Northeast Region

Lebanon, NJ
Tel: (908) 236 4121

Pacific Region

Buena Park, CA
Tel: (714) 228 2509

Southern Region

Alpharetta, GA
Tel: (770) 619 9767

Canada

Milton, Ontario
Tel: (905) 693 3000

México

Toluca, Edo. de México
Tel: (52) 72 2275 4200

Mobile

USA

Global Mobile

Lincolnshire, IL
Tel: (847) 821 1500

Central Region

Lincolnshire, IL
Tel: (847) 821 1500

Eastern Region

North Canton, OH
Tel: (330) 284 3355

Midwest Region

Hiawatha, IA
Tel: (319) 393 1221

Southern Region

Aledo, TX
Tel: (817) 441 1794

Western Region

Buena Park, CA
Tel: (714) 228 2509

Canada

Milton, Ontario
Tel: (905) 693 3000

México

Apodaca, N.L.
Tel: (52) 81 8156 6000

Truck

USA

Eastern Region

Cleveland, OH
Tel: (440) 519 1125

Western Region

San Ramon, CA
Tel: (925) 735 9573

Canada

Milton, Ontario
Tel: (905) 693 3000

México

Apodaca, N.L.
Tel: (52) 81 8156 6000

Europe

Austria

Wiener Neustadt
Tel: (43) 2622 23501 0

Belgium

Nivelles
Tel: (32) 67 280 900

Czech Republic and Slovakia

Klecany
Tel: (420) 284 083 111

Denmark

Ballerup
Tel: (45) 4356 0400

Finland

Vantaa
Tel: (358) 20 753 2500

France

Contamine-sur-Arve
Tel: (33) 4 50 25 80 25

Germany

Kaarst
Tel: (49) 2131 4016 0

Greece

Athens
Tel: (30) 210 933 6450

Hungary

Budapest
Tel: (36) 1 220 4155

Ireland

County Dublin, Baldonnell
Tel: (353) 1 466 6370

Italy

Corsico, Milano
Tel: (39) 02 45 19 21

The Netherlands

Oldenzaal
Tel: (31) 541 585000

Norway

Ski
Tel: (47) 64 91 10 00

Poland

Warsaw
Tel: (48) 22 57 32400

Portugal

Leca da Palmeira
Tel: (351) 22 999 7360

Romania

Bucharest
Tel: (40) 21 252 1382

Russia

Moscow
Tel: (7) 495 580 9145

Slovenia

Novo Mesto
Tel: (386) 7 337 6650

Spain

Madrid
Tel: (34) 91 675 7300

Sweden

Spanga
Tel: (46) 8 597 95000

Ukraine

Kiev
Tel: (380) 44 494 2731

United Kingdom

Warwick,
Tel: (44) 1926 317878

Asia Pacific

Australia

Castle Hill
Tel: (61) 2 9634 7777

China

Beijing
Tel: (86) 10 6561 0520

Shanghai

Tel: (86) 21 5031 2525

Hong Kong

Tel: (852) 2428 8008

India

Mahape, Navi Mumbai
Tel: (91) 22 5613 7081

Korea

Seoul
Tel: (82) 2 559 0400

Malaysia

Subang Jaya
Tel: (60) 3 5638 1476

New Zealand

Mt. Wellington
Tel: (64) 9 574 1744

Japan

Tokyo
Tel: (81) 3 6408 3900

Singapore

Jurong Town
Tel: (65) 6 887 6300

Taiwan

Taipei
Tel: (886) 2 2298 8987

Thailand

Bangkok
Tel: (662) 717 8140

Middle East

United Arab Emirates

Abu Dhabi
Tel: (971) 2 678 8587

Latin America

Pan American Division

Miami, FL
Tel: (305) 470 8800

Argentina

Buenos Aires
Tel: (54) 33 2744 4129

Brazil

Cachoeirinha RS
Tel: (55) 51 3470 9144

Venezuela

Caracas
Tel: (58) 212 238 5422

Africa

South Africa

Kempton Park
Tel: (27) 11 961 0700

