

220 Mobile Piston Pump Catalog Design Code B

AEC018 280 bar [4060 psi]
AEC028 280 bar [4060 psi]



ENGINEERING
TOMORROW

Content

Model codes	2
Specifications and performance	4
Control options	
Pressure & Flow (Load Sense) Compensator	5
Pressure Compensator.....	7
Remote Pressure Control (RPC)	8
Electronic Displacement Control (EDC)	9
EH Inverse Proportional Pressure Control (IPPC)	10
Electronic Destroke (Cold Start) Valve	11
Performance	
AEC018.....	12-13
AEC028.....	14-15
Pump installation	
AEC018 A-Mount standard - side-ported	16
AEC018 A-Mount AG version - rear-ported.....	17
AEC028 B-Mount - rear-ported	18
AEC028 B-Mount - side-ported	19
AEC028 Thru drive SAE-A	20
AEC028 Thru drive SAE-B	21
AEC018- Pressure & Flow (Load Sense) Compensator	22
Control installation	
AEC-028 Pressure & Flow (Load Sense) Compensator	23
ACE028- Electronic Displacement Control (EDC).	24
AEC018 Maximum Stroke Limiter	25
AEC018 Cold start valve	26
Input shaft options	27-28
Installation and start-up	29

Introduction

220 Series Piston Pump

The Danfoss X20 portfolio of open-circuit piston pumps is built to maximize machine performance and productivity. With sophisticated controls that enhance system efficiency and a compact design that delivers incredible power, the X20 portfolio empowers mobile machine operators to do more work in less time using less fuel.

Sophisticated controls that improve performance while optimizing efficiency.

Excellent pressure responsiveness – The X20 portfolio delivers the fastest response and recovery times in the open-circuit piston segment, helping customers get the job done faster.

Low standby pressure – The X20 portfolio can maintain low margin pressure (~150 psi) with exceptional stability, reducing heat generation and helping to eliminate wasted energy.

Stable fan drive functionality – Danfoss' fan drive control reaches desired speed more quickly and remains stable once there, reducing energy-wasting oscillation.

Advanced electronic controls – The cold start and fan drive controls are Plus+1 ready, meaning they can be easily configured with pre-programmed development tools and controlled electronically for maximum flexibility and precision.

Winning load sense combination – X20 works in conjunction with Danfoss' CLS Load Sense Sectional Mobile Valve, providing OEMs one resource for their machine's load sense needs.

Compact design that enables greater flexibility and cost savings.

Simplified pump architecture – The X20 pump has 25% fewer components than traditional pumps, reducing the number of leak points and simplifying maintenance.

Compact package size – The X20 portfolio's small size satisfies Tier 4 requirements and provides more flexibility when designing the engine compartment.

More horsepower – The compact rotating group delivers a remarkable amount of horsepower, improving productivity without using more fuel.

One-piece housing – Single-piece pump housing removes leak points and makes maintenance faster and easier versus more complicated multi-piece housings.

Multiple options that make it easy to specify exactly what you need.

Variety of control options – Including pressure control, load sense, cold start, torque control, remote pressure control, inverse proportional pressure control, proportional pressure control, electronic displacement control, and swash sensor feedback, giving you more ways to design more efficient, productive machines.

Several displacement options – With seven displacement options, there's an X20 pump to fit virtually any mobile application need. The 220 series is currently available in 18cc (1.09 cu. inch) & 28cc (1.71 cu. inch) displacement. It is rated for 280 bar & up to 3,600 rpm and is capable of generating up to 52.6 horsepower (39.2kW), making it the ideal pump for an array of different mobile and stationary applications. The combination of high load capacity bearings and a stiff drive shaft help provide a pump B10 bearing life of up to 5,850 hours at rated mobile conditions, reducing operating costs and extending operating life.



Variety of mounting options – The X20 portfolio is available with both SAE and ISO mounting flange configurations, can be side- or rear-ported, and offers multiple drain ports to help overcome any installation challenges.

Exceptional quality that provides remarkable reliability.

Unique control piston design – Single-acting control piston with special coating helps minimize friction, increasing operating life.

Bronze piston shoes – Bronze piston shoes are robust against contamination should particles enter the fluid, enhancing system performance and component service life.

High-load bearings – Larger, more durable bearings resist wear and deliver industry-leading bearing life.

3-year manufacturer's warranty – Danfoss warranty terms provide peace of mind for three full years, helping you get through your warranty period with complete confidence.

Global network of Danfoss certified experts for end-to-end support.

More partners in more regions – Growing network of Danfoss distributors around the world ensures there's local service and support anywhere you need it.

World-class system design and assembly – Our expert distribution partners can help with everything from specifying to prototyping and assembly to commissioning, so you can focus on other areas of your business.

Danfoss standardized practices and processes – Danfoss employs a unique system of tools and processes, known as the Danfoss Business System, to ensure quality development and delivery of the X20 product. These tools and process include such known methods as Design for Six Sigma, Lean Manufacturing and ISO certification.

Model codes

220 Series Mobile Piston Pump

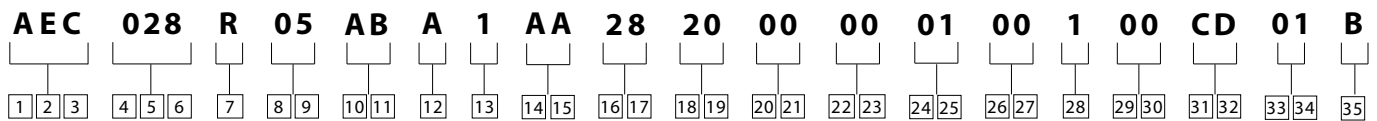

1 2 3 Pump series
AEC – 220 Series open circuit piston pump

4 5 6 Pump displacement
018 – 18.0 cm³/r [1.09 in³/r]
028 – 28.0 cm³/r [1.71 in³/r]

7 Input shaft rotation
L – Left hand
R – Right hand

8 9 Front mount and shaft
05 – 2 Bolt B, 22.2 mm (0.88) dia. keyed shaft
09 – 2 Bolt B, 13 Tooth 16/32 Spline
31 – 2 Bolt B, 25.4 mm (1.00 in) dia. straight keyed
34 – 2 Bolt B, 15 Tooth 16/32 spline
48 – 2 Bolt A, 11 Tooth 16/32 spline, 38 mm [1.5 in] ext. [18cc only]
49 – 2 Bolt A, 1:8 Taper 16.66 mm [0.655 in] dia. 39.7 [1.56] ext [for 18cc AG variant only]
50 – 2 Bolt A, 9 Tooth 16/32 spline [for 18cc only]
51 – 2 Bolt A, 19.02 mm [.749 in] dia. keyed shaft, 32 mm [1.26 in] ext. [for 18cc only]
52 – 2 Bolt A, 15.85 mm [.624 in] dia. keyed shaft, 32 mm [1.26 in] ext. [for 18cc only]

10 11 Main ports size & location
AA – Rear port
 Suction - 1.625 - 12 SAE O-Ring
 Pressure - 1.0625 - 12 SAE O-Ring
AB – Side Port
 Suction - 1.625 - 12 SAE O-Ring
 Pressure - 1.0625 - 12 SAE O-Ring
AC – Rear port [for 28cc only]
 Suction - M42 X 2 Metric O-Ring,
 Pressure - M27 X 2 Metric O-Ring
AD – Side port
 Suction - M42 X 2 Metric O-Ring
 Pressure - M27 X 2 Metric O-Ring
AE – Rear port [for 28cc only]
 Suction - 1.25" (code 61) with .4375 - 14 UNC- 2B Threads,
 Pressure - .75" (Code 61) with .375 - 16 UNC -2B Threads
AF – Side port suction - 1.25" (Code 61) with .4375 - 14 UNC- 2B threads
 Pressure - .75" (Code 61) with .375 - 16 UNC -2B threads
AG – Rear ports [for 28cc only]
 Suction - M48 Metric O-Ring,
 Pressure - M33 Metric O-Ring

12 Case drain ports
A – .875 - 14 SAE O-ring - top
B – .875 - 14 SAE O-ring - bottom
C – M22 X 1.5 metric o-ring - top
D – M22 X 1.5 metric o-ring - bottom
G – .75 - 16 SAE O-ring - vertical
H – M18 X 1.5 Metric o-ring - vertical
L – .75-16 SAE O-ring - top

13 Diagnostic pressure ports
1 – .4375 - 20 SAE O-ring port - plugged
2 – M12 X 1.5 metric O-ring port - plugged

14 15 Controller type
AA – Pressure flow compensator with .4375 - 20 SAE o-ring load sense port#
AB – Pressure flow compensator with M12 X 1.5 Metric o-ring load sense port
AC – Pressure compensator only
AP – Remote pressure control M12 metric O-ring port, left side [for 28cc only]
AT – Pressure and flow compensator with electronic displacement control - EP type [for 28cc only]
AV – EH inverse proportional pressure control (vertical mounting) [for 28cc only]
AW – Remote pressure control with .4375-20 SAE o-ring port, left side#
AY – Pressure and flow compensator with electronic displacement control - EPD type [for 28cc only]
BB – Pressure comp. w/electro hyd. proportional pressure control (EHPPC) [for 28cc only]
BH – Remote pressure control w/ M12 x 1.5 metric o-ring port (left side) & electronic displacement control - EP type [for 28cc only]

16 17 Pressure compensator setting (Tolerance on setting)*
02 – 76 - 83 bar (1100-1200 lbf/in²)
26 – 197 - 203 bar (2850-2950 lbf/in²)
34 – 234 - 241 bar (3400-3500 lbf/in²)
43 – 276 - 283 bar (4000-4100 lbf/in²)

18 19 Flow compensator / remote pressure control setting (tolerance on setting)
00 – No flow compensator setting
14 – 12 - 15 bar (180-220 lbf/in²)
20 – 17 - 20 bar (250-290 lbf/in²)

20 21 Torque control setting
00 – No torque control

22 23 Control special features
00 – No control special features
0A – Bleed down orifice
0B – 24V Cold start valve
0S – 12V DC Solenoid AMP Jr connector (used with EH inverse proportional pressure control)
0P – Load sense steel tube connected to integrated shuttle valve [for 18cc AG pump only]
0T – 24V DC Solenoid AMP Jr connector (used with EH inverse proportional pressure control)
0U – 12V DC solenoid deutsch connector (used with EH inverse proportional pressure control)
0V – 24V DC solenoid deutsch connector (used with EH inverse proportional pressure control)

Model codes

220 Series Mobile Piston Pump

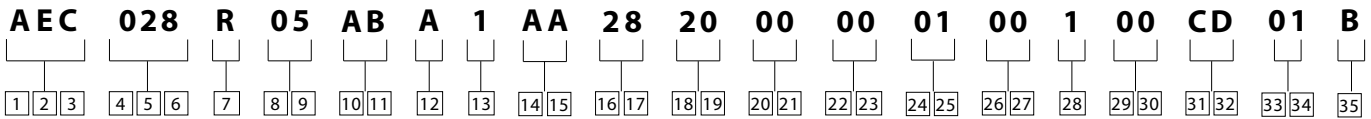

[24][25] Maximum displacement option*
01 – Standard displacement (as given in code title)
02 – External manual stroke adjustment set at max

[26][27] Auxiliary (rear) mount & output shaft [for 28cc only]
00 – No auxiliary mounting features
AA – SAE A -2 Bolt, 9T 16/32 spline
AB – SAE A- 2 Bolt, 11T 16/32 spline
AC – SAE B- 2 Bolt, 13T 16/32 spline
AG – Auxiliary mount ready with cover plate

[28] Shaft seal
1 – Standard vitonshaft seal
2 – Nitrile shaft seal

[29][30] Pump special features
00 – No special features
AB – Swash position sensor
AE – Rear port end cover with integrated priority and shuttle valve [for 18cc AG pump only]

[31][32] Paint
00 – No paint
0B – Black
CD – Blue primer

[33][34] Identification/packaging
01 – Standard Danfoss identification box packaging

[35] Design level
B – Second design

1 *Additional Settings Available by Request, including fixed displacement stops.
 2 # -RecommendRPC pressure settings 10-21 bar (140-350 psi)

Specifications and performance

220 Series Mobile Piston Pump

General performance specifications

		Units	AEC018	AEC028
Displacement		cc/r (in ³ /r)	18 (1.09)	28.0 (1.71)
Mounting (SAE)			2 Bolt A	2 Bolt B
Pressure	Continuous	bar (psi)	280 (4060)	280 (4060)
	Intermittent ¹		320 (4600)	320 (4600)
	Peak ²		350 (5000)	350 (5000)
Speed ³	At 1 bar abs (0 psig)	rpm	3600	3000
	At .85 bar abs (5 in.Hg)		3000	2700
	Max (standby)		3900	3600
	Min		500	500
Power	Max (theoretical)	kW (hp)	30.15 (40.43)	39.2 (52.6)
	Standby		1.62 (2.17)	2.1 (2.8)
Torque	Max (theoretical)	Nm (lb-ft)	80 (59)	125 (92)
Weight ⁴		kg (lbm)	13.2 (29.1)	16.3 (35.9)
Bearing life ⁵	At 140 bar (2030 psi)	B10 Hours	16,222	62,000
	At 210 bar (3045 psi)		4,200	16,000
	At 280 bar (4060 psi)		1,610	5,850
Mass moment of inertia		Kg-m ² (lbm-ft ²)	0.003 (0.075)	0.005 (0.119)

- 1 Less than 10% of duty cycle.
- 2 Momentary system pressure spikes only.
- 3 Ratings based on flange ports.
- 4 Standard non-through drive pump.
- 5 Bearing life ratings at rated speed – 1 bar abs (0 psig) inlet. Will vary based on thrust and side loads.

Inlet pressure, case pressure, and operating temperature requirements

Inlet pressure			Case pressure			Operating temperature		
Rated	Minimum	Maximum	Maximum continuous	Maximum intermittent	Peak	Rated	Minimum temperature	Maximum intermittent
bar abs (psig)	bar abs (in. Hg)	bar abs (psig)	bar abs (psig)	bar abs (psig)	bar abs (psig)	°C (°F)	°C (°F)	°C (°F)
1.0 (0)	0.85 (5)	4.4 (50)	1.3 (5)	3.1 (30)	6.2 (75)	93 (200)	-37 (-35)	104 (220)

Hydraulic fluids

Fluid	Recommended operating viscosity range cSt (SUS)	Maximum continuous cSt (SUS)	Maximum viscosity at startup cSt (SUS)	Minimum viscosity @ max. Temperature of 93°C (200°F) cSt (SUS)	Minimum intermittent cSt (SUS)
Use antiwear hydraulic oil, or automotive type crankcase oil (designations SC, SD, SE or SF) per SAE J183 FEB80	16 to 40 (80 to 188)	430 (1192)	2100 (9720)	10 (59)	6 (46)

For more information, see Danfoss publication 579. For operation on other alternative or environmentally friendly fluids, please contact your Danfoss Representative.

Control options

Pressure & Flow (Load Sense) Compensator for AEC018 AG variant only

The Agricultural tractor variant of 220 pump has a shuttle valve integral into pump end cover which senses the highest load of the two-work circuit and a priority valve to set the flow priority. For tractor application steering is given priority over other auxiliary functions like hitch circuit for implements .

Fluid output from the pump end cover enters into the priority valve before reaching to system . Integrated priority valve gives the pump flow priority to Steering system over the Hitch valve of the tractor. The shuttle valve senses highest of the two load pressures (Steering load or Hitch system load) and gives the load sense signal to flow control of the pump to adjust the pump flow as per the load requirement. The load signal is carried through steel pipe from end cover to pump controller.

These features make this pump suitable for other platforms where shuttle and priority valve are required .

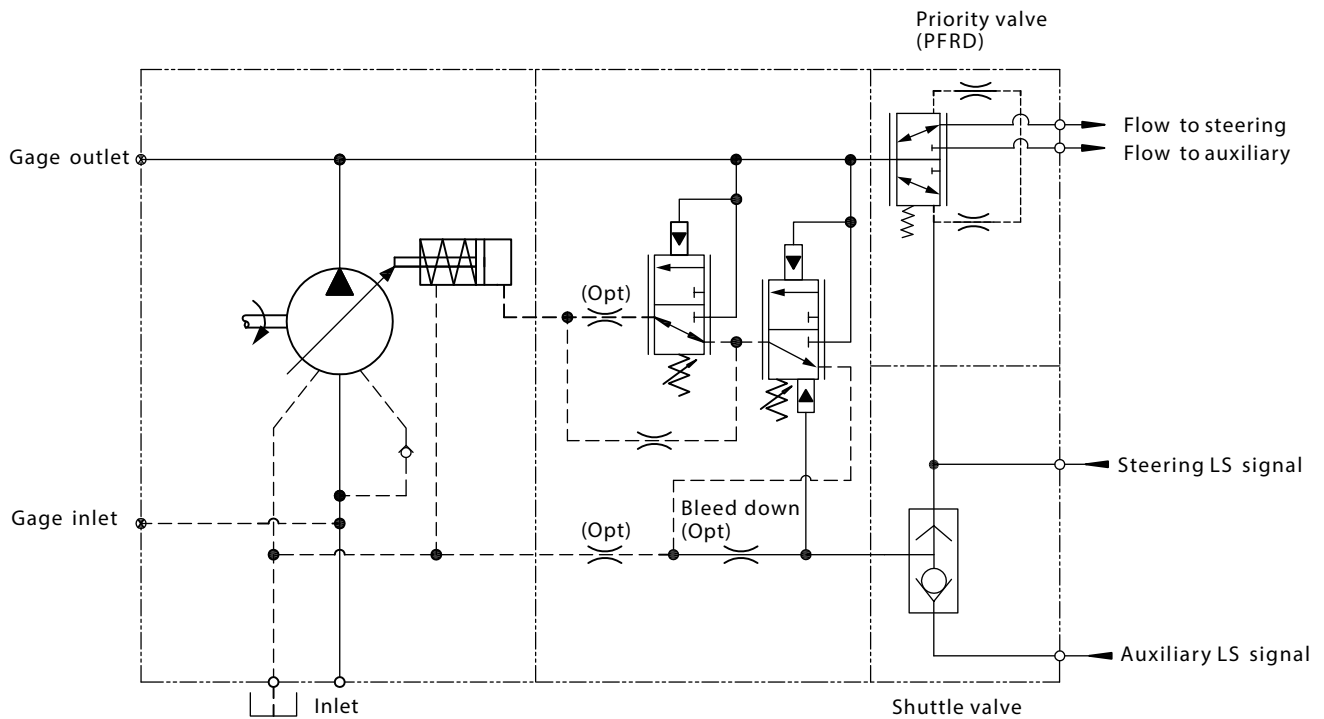

Control options

Pressure & Flow (Load Sense) Compensator

The pump will provide flow & pressure matching of pump output to system load demand, maximizing efficiency and improving load metering characteristics of any directional control valve installed between the pump and the load. Load sensing ensures that the pump always provides only the amount of flow needed by the load. The pump operating pressure adjusts to the load pressure plus a pressure differential required for the load sense margin. When the system is not demanding flow, the load sense control will operate in low pressure zero flow, energy saving stand-by mode. The differential pressure is the difference between the pressure inlet and service port of a proportionally controlled directional valve, or a load sensing directional control valve. See the model code for differential pressure settings for load sensing. If the load pressure exceeds the system pressure setting, the pressure compensator reduces pump displacement. The load sensing line must be as short as possible and can also be used for remote pressure control or unloading of the pump pressure. For remote pressure control purposes, it is recommended that you contact your Danfoss representative for the correct configuration of the control.

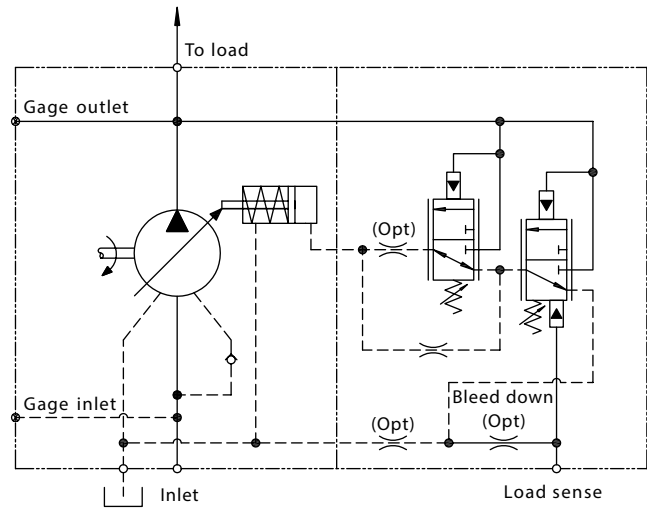

Warning:

- When adjusting the pressure limiter, install a 0 to 350 bar (0 to 5000 psi) gage in the outlet gage port and limit the pressure setting to the continuous rated pressure for the pump displacement. It is possible to adjust the pressure compensator beyond the rated pressure of the pump. Doing so, may void the warranty of the pump.
- Danfoss recommends use of relief valve in all systems.

Pressure limit settings

The pressure compensator uses two springs to cover the full pressure range of the X20 pumps.

Spring 1 = < 140 bar (2050 psi)

Spring 2 = 145 - 280 bar (2100 - 4060 psi)

Flow Compensator (Load Sense) settings

There are two springs used to cover the load sense adjustment range of this control. Available load sense range is

Spring 1 = < 20 bar (290 psi)

Spring 2 = 21 - 42 bar (300-609 psi)

Typical operating curve

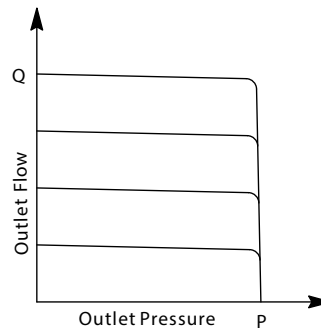

Dynamic response per SAE J745 (using swash plate position)

	Response (off stroke)	Recovery (on stroke)	Load sense recovery
	msec	msec	msec
AEC018	25	50	40
AEC028	14	49	49

Control options

Pressure Compensator

The pump will provide a continuously modulated flow to meet changing load demands at a pre-adjusted compensator pressure. At pressures below the compensator setting, the pump will operate at maximum displacement. See model code position #16, 17 for compensator pressure ranges.

Warning:

- When adjusting the pressure limiter, install a 0 to 350 bar (0 to 5000 psi) gage in the outlet gage port and limit the pressure setting to the continuous rated pressure for the pump displacement. It is possible to adjust the pressure compensator beyond the rated pressure of the pump. Doing so, may void the warranty of the pump.
- Danfoss recommends use of relief valve in all systems.

Pressure limit settings

The pressure compensator uses two springs to cover the full pressure range of the X20 pumps.

Spring 1 = < 140 bar (2050 psi)

Spring 2 = 145 - 280 bar (2100 - 4060 psi)

310 bar (4496 psi for 74 cc pump)

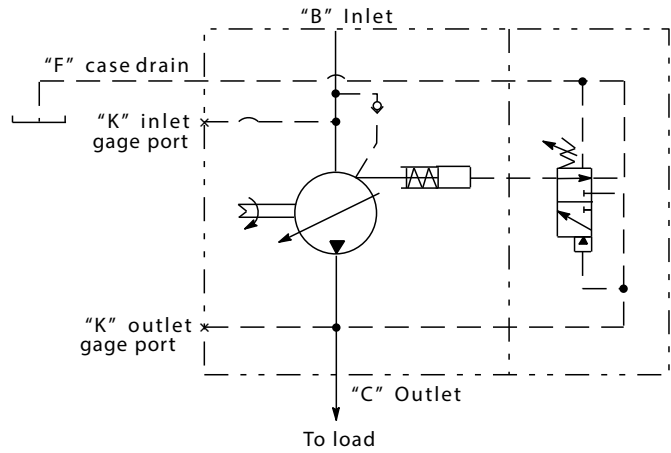

Pressure cut-off characteristics of pressure compensator control @ 49°C (120°F), static conditions.

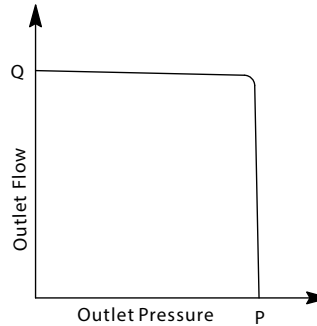

Dynamic response per SAE J745 (using swash plate position)

	Response (off stroke)	Recovery (on stroke)
	msec	msec
AEC018	25	50
AEC028	20	65

Control options

Remote Pressure Control(RPC) for AEC028

Remote relief valve is to be connected to pilot port "J" through necessary external piping. Standard differential pressure of 20 bar is set at RPC spool. The required outlet pressure (below 280 bar) can be set by adjusting remote relief valve setting. Once pressure reaches preset value, flow across remote relief valve starts, this results in RPC spool movement due to pressure imbalance. This will de-stroke the pump to maintain the set pressure.

Secondary fixed pressure compensator is provided to limit the max pressure setting as a fail safe measure.

Note

- Flow Compensator is not available with RPC.
- When selecting this option in the model code, a pressure setting value must be identified in the flow compensator field. Select a range of 10-24 bar (140-350 psi), default is 20. The setting selected is the RPC differential pressure.
- Remote relief valve is not included in supply scope of the pump.

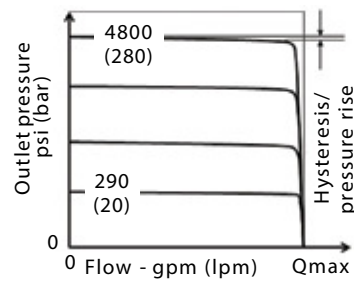

Delta pressure setting at control valve - bar (psi)	14 - 24 (200 - 350)
Control fluid consumption - lpm (gpm)	4.5 (1.2) max.
Recommended flow rating of remote relief valve- lpm (gpm)	3 - 5 (0.8 - 1.32)
Recommended Danfoss Relief Valve part number	RV5-10-S-0-50

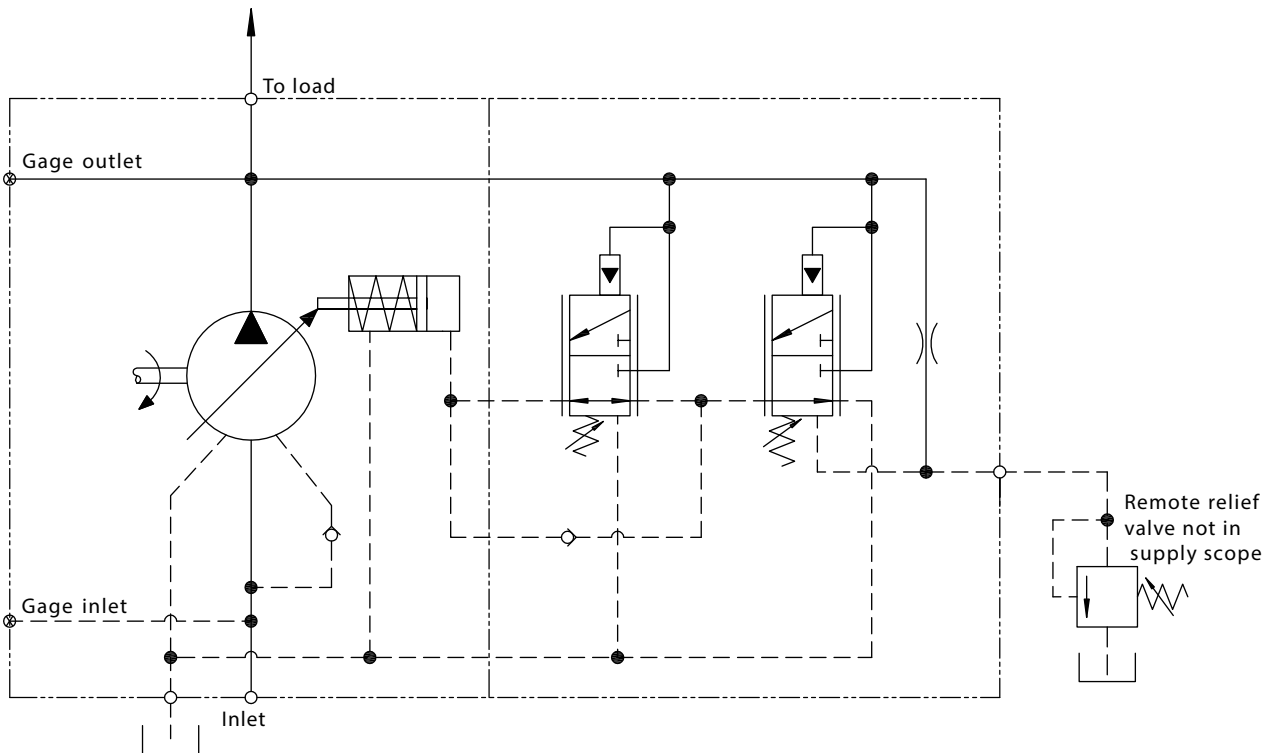

Control options

Electronic Displacement Control (EDC) for ACE028

Pump displacement can be controlled infinitely, as per the current signal provided to the solenoid control valve. The integrated pump control makes use of an external current signal to vary the pump displacement. This control has a proportional characteristic i.e. with increasing current signal, the displacement increases proportionately.

This control is with manual override. Based on fail safe condition there are two types:

- Min type (EP):** Return to min displacement in case of power loss.
- Max type (EPD):** Return to max displacement in case of power loss

Warning:

- When adjusting the pressure limiter, install a 0 to 350 bar (0 to 5000 psi) gage in the outlet gage port and limit the pressure setting to the continuous rated pressure for the pump displacement. It is possible to adjust the pressure compensator beyond the rated pressure of the pump. Doing so, may void the warranty of the pump.
- Danfoss recommends use of relief valve in all systems.

Pressure limit settings

The EDC can operate between 20 bar (290 psi) and 280 bar (4060 psi).

Electrical data

	12 V DC	24 V DC
Voltage	12 V DC	24 V DC
Max Current	1500 mA	750 mA
R20, Resistance(ohm)	5.19 +/- 0.52%	20.8 +/- 2.08
Type of Control	Current	Current
Recommended PWM Frequency	250 Hz	250 Hz
Dither Frequency	75 Hz	75 Hz
Dither Amplitude	300 mA	300 mA
Duty Cycle	100%	100%
Insulation material	Class H, 180 deg C	Class H, 180 deg C
Protection Class	IP69K	IP69K
Connector	Deutsch	Deutsch
Operating Temperature	-40 deg C; 85 deg C	-40 deg C; 85 deg C

This control has manual override. Hysteresis less than 5%. For cold start function,

Control type	Supply current (mA)	
	12V	24V
EP	0	0
EPD	480	240

EP type

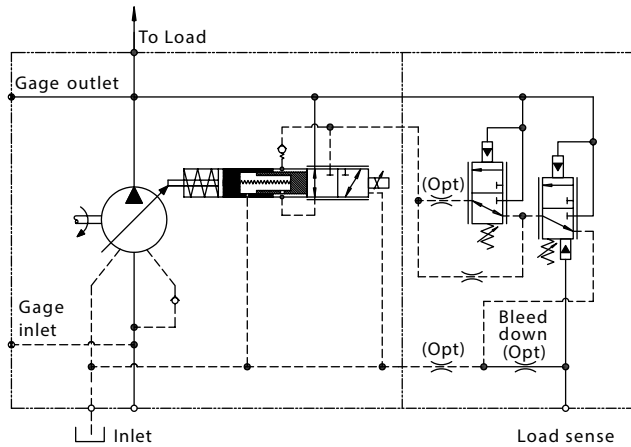

EPD type

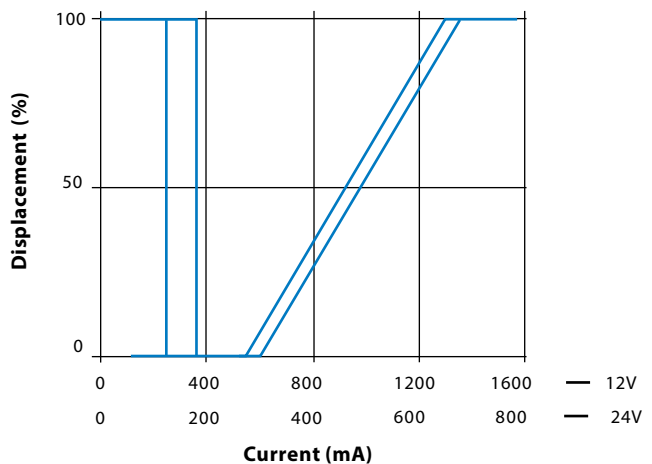
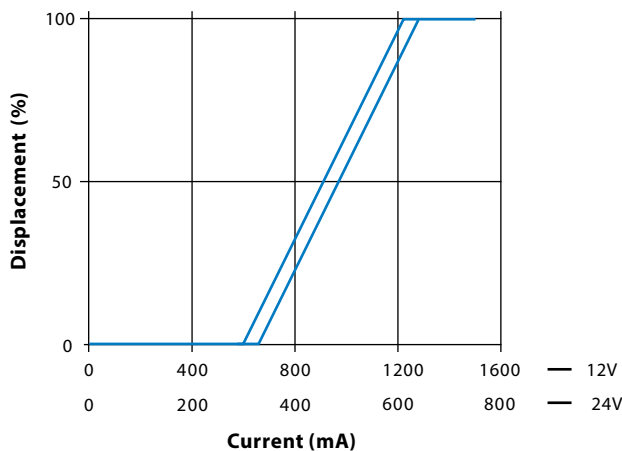
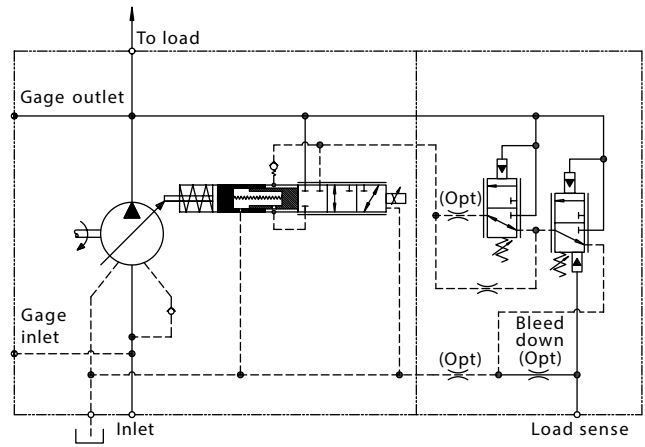

Control options

EH inverse proportional pressure control (IPPC) for AEC028

The EH Inverse Proportional Pressure control allows for stepless variation of the max pump output pressure, as per the current signal provided to the control valve solenoid.

The integrated pump control makes use of an external current signal to vary the pump output pressure

This control has an inverse proportional characteristic i.e. with increasing current signal, the max output pressure is proportionately reduced

Warning:

- When adjusting the pressure limiter, install a 0 to 350 bar (0 to 5000 psi) gage in the outlet gage port and limit the pressure setting to the continuous rated pressure for the pump displacement. It is possible to adjust the pressure compensator beyond the rated pressure of the pump. Doing so, may void the warranty of the pump.
- Danfoss recommends use of relief valve in all systems.

Pressure limit settings

The minimum is 110 bar and max pressure can be set from 140 bar (2050 psi) to 280 bar (4060 psi).

Electrical data

Voltage	12 V	24 V
Max Current	1500 mA	750 mA
R20, Resistance (ohm)	5.3 +/- 5%	21.2 +/- 5%
Type of Control	Current	Current
Recommended PWM	100 Hz	100 Hz
Frequency		
Duty Cycle	100%	100%
Insulation material	Class H, 180 deg C	Class H, 180 deg C
Protection Class	IP6K6/IP69K	IP6K6/IP69K
Connector	AMP Junior Power Timer/ Deutsch Connector DT04-2P	AMP Junior Power Timer/ Deutsch Connector DT04-2P
Operating Temperature	-30 deg C; 105 deg C	-30 deg C; 105 deg C

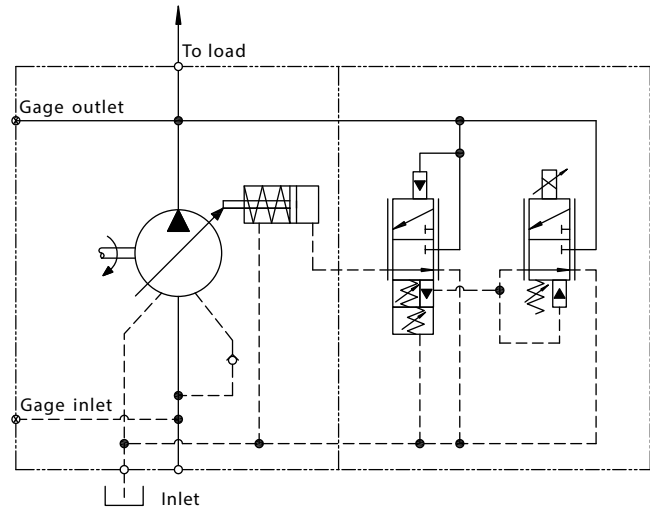

Typ. Current vs pressure characteristics of IPPC at 1800 rpm at various max pressure settings at 49 deg C (120deg F), static conditions.

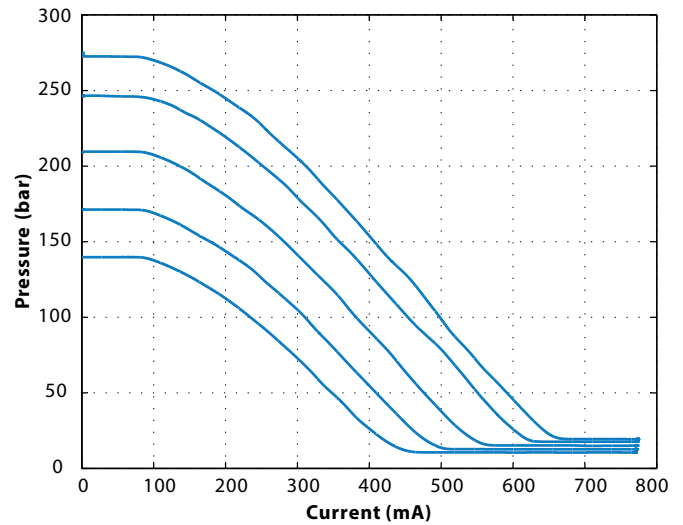

Control options

Electronic Destroke (Cold Start) Valve

The Electronic Destroke Valve reduces pump start-up torque by directing outlet pressure to the control piston.

It is primarily used in cold weather applications and includes a 12 or 24 VDC directional control valve mounted between the pump housing and compensator.

Refer model code position 22,23 - control special features for available connector options

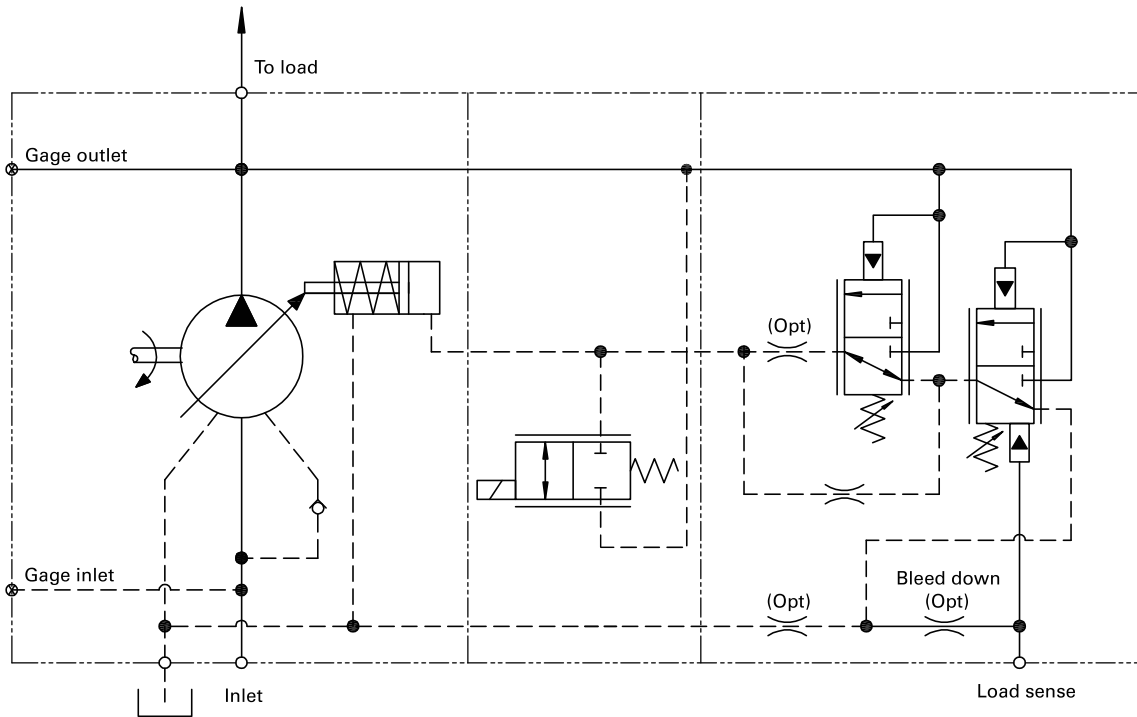

Overall efficiency versus speed @ 49°C (120°F, full flow, and 1.0 bar (0 psi) Inlet

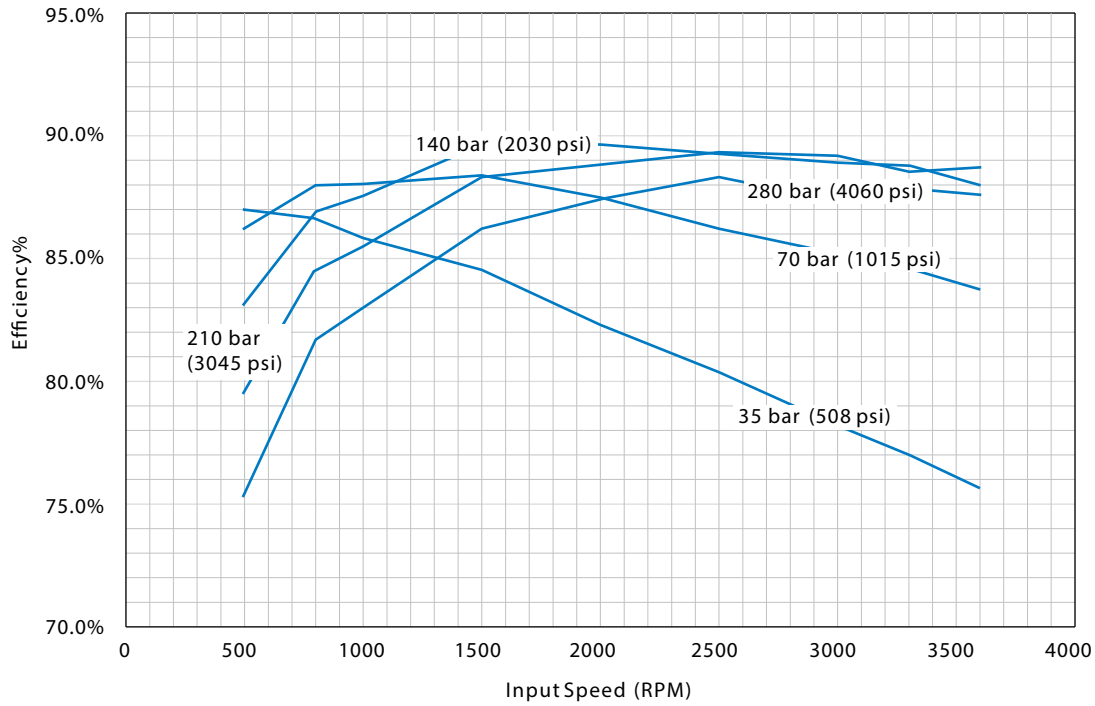

Input power versus speed @ 49°C (120°F), full flow, and 1.0 bar (0 psi) Inlet

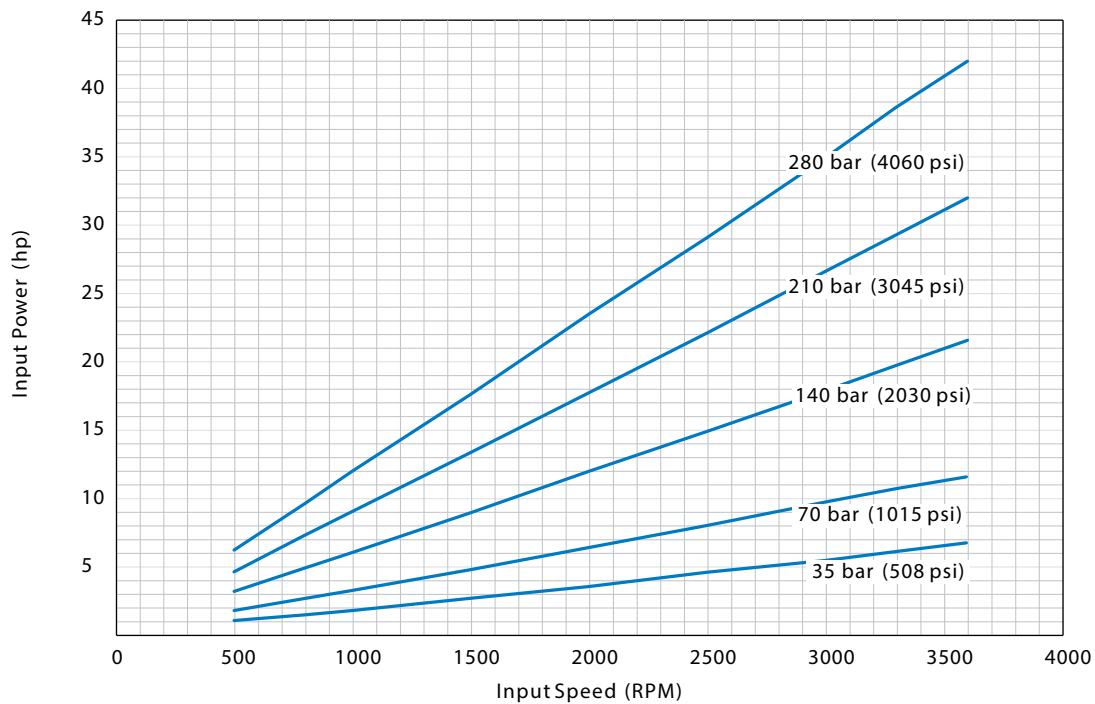

Performance

AEC018

Input Torque Versus Speed @ 49°C (120°F), FullFlow, and 1.0 bar (0 psi) Inlet

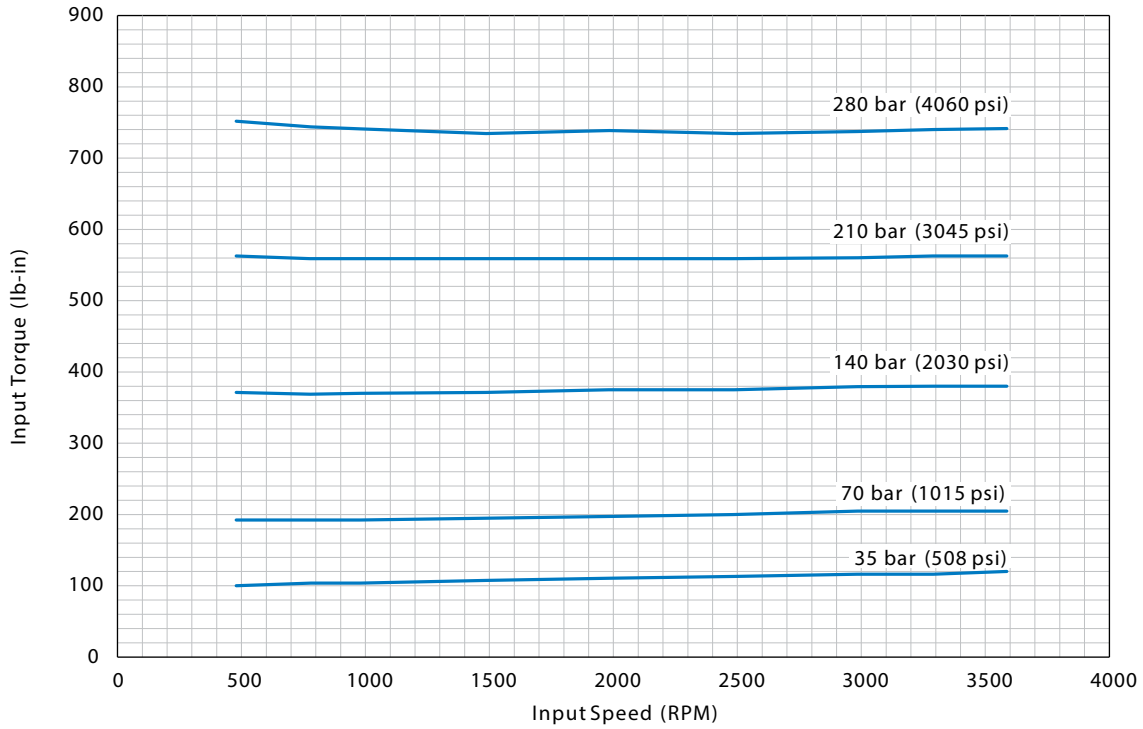

Delivery & Case Flow Versus Speed @ 49°C (120°F), FullFlow, and 1.0 bar (0 psi) Inlet

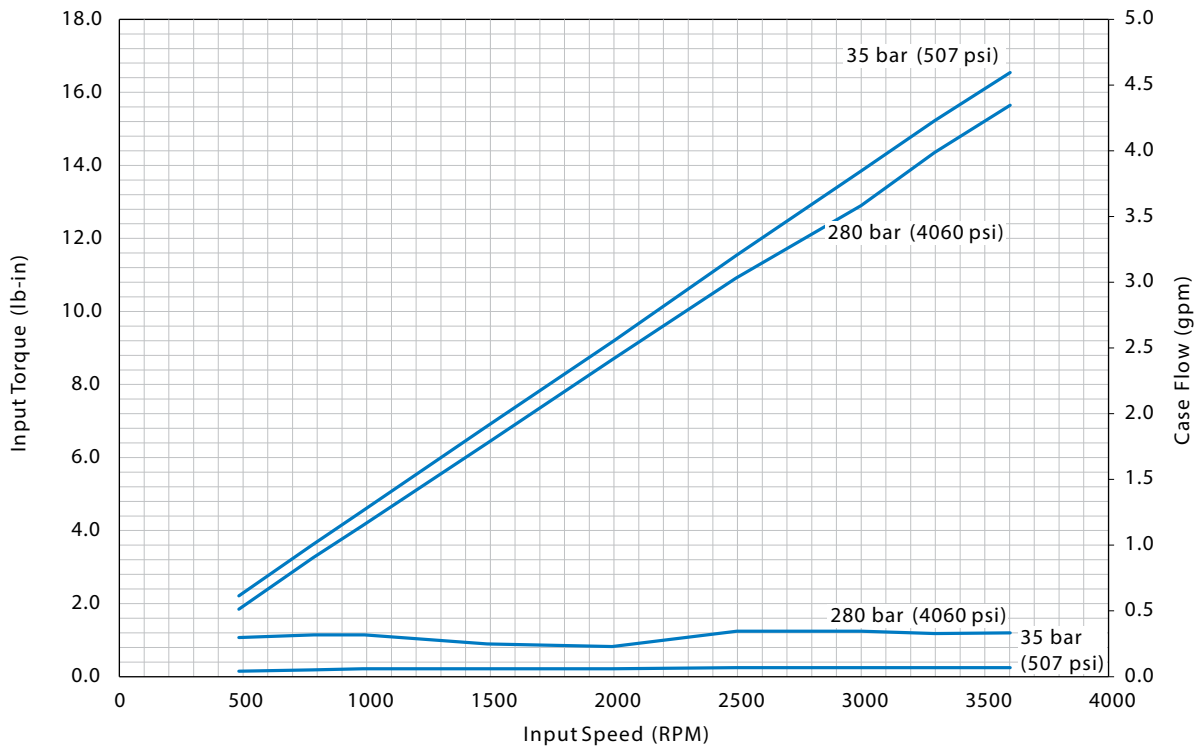

Overall efficiency versus speed @ 49°C (120°F), full flow, and 1.0 bar (0 psi) Inlet

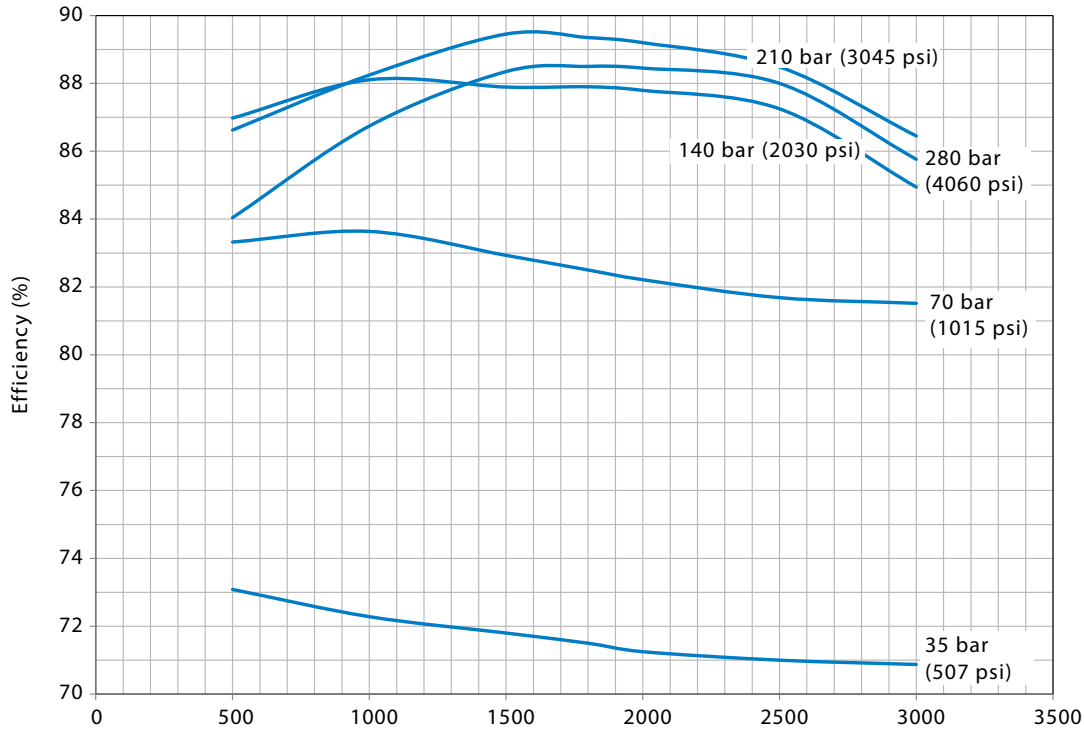

Input power versus speed @ 49°C (120°F), full flow, and 1.0 bar (0 psi) Inlet

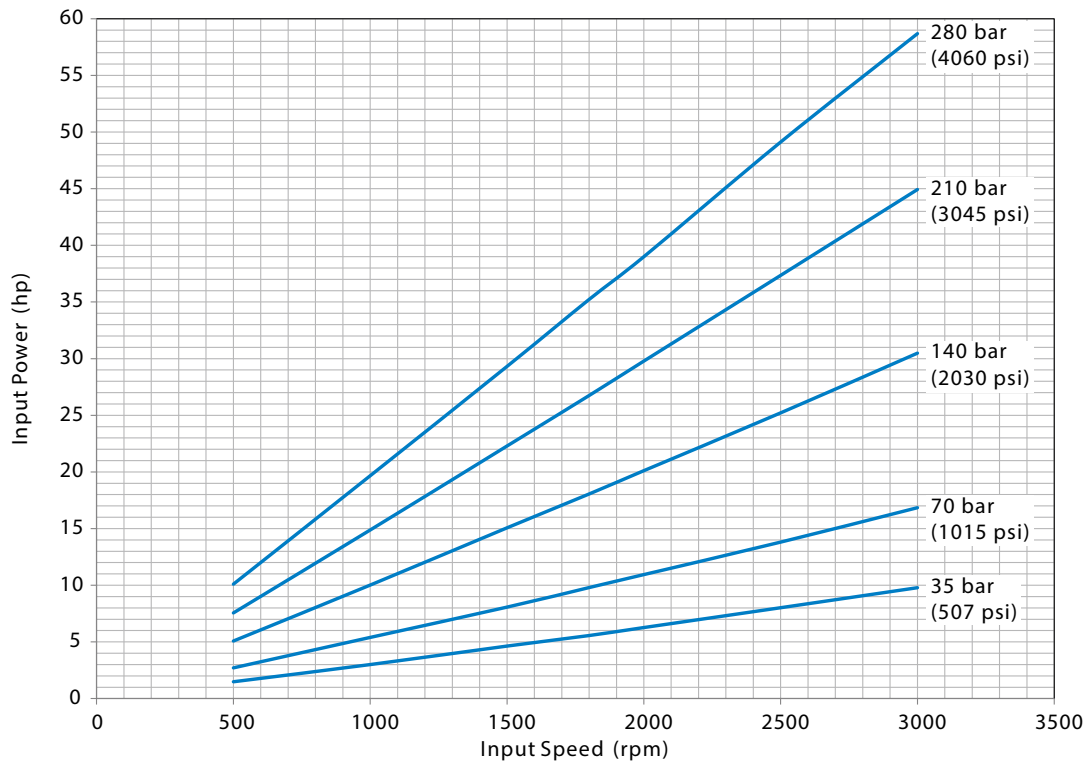

Performance

AEC028

Input torque versus speed @ 49°C (120°F), full flow, and 1.0 bar (0 psi) Inlet

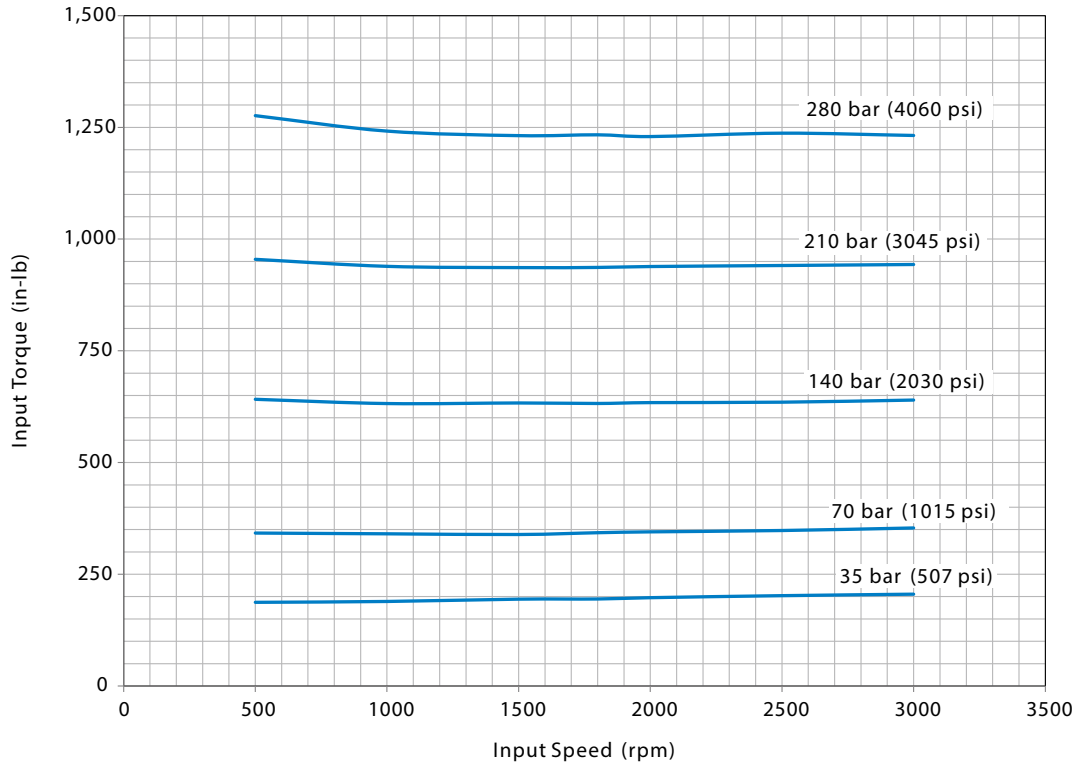

Delivery and case flow versus speed @ 49°C (120°F)

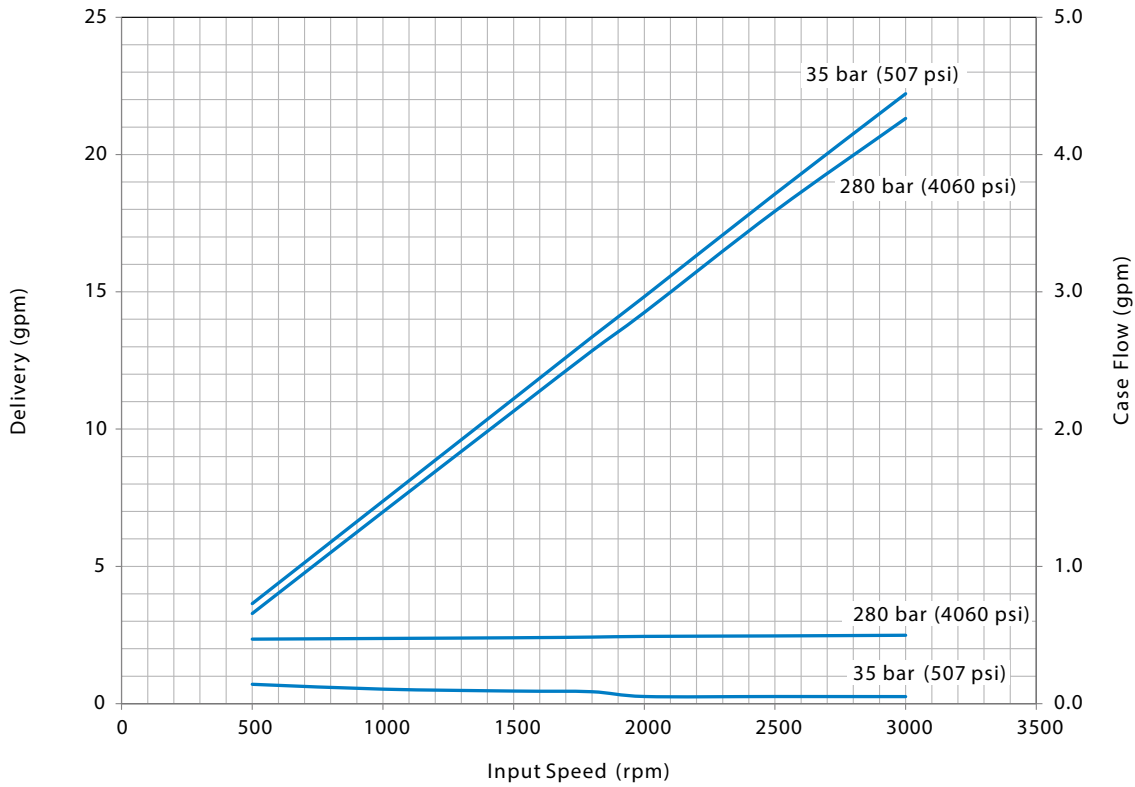

Pump installation

AEC018 A-Mount standard - side-ported

RH Rotation

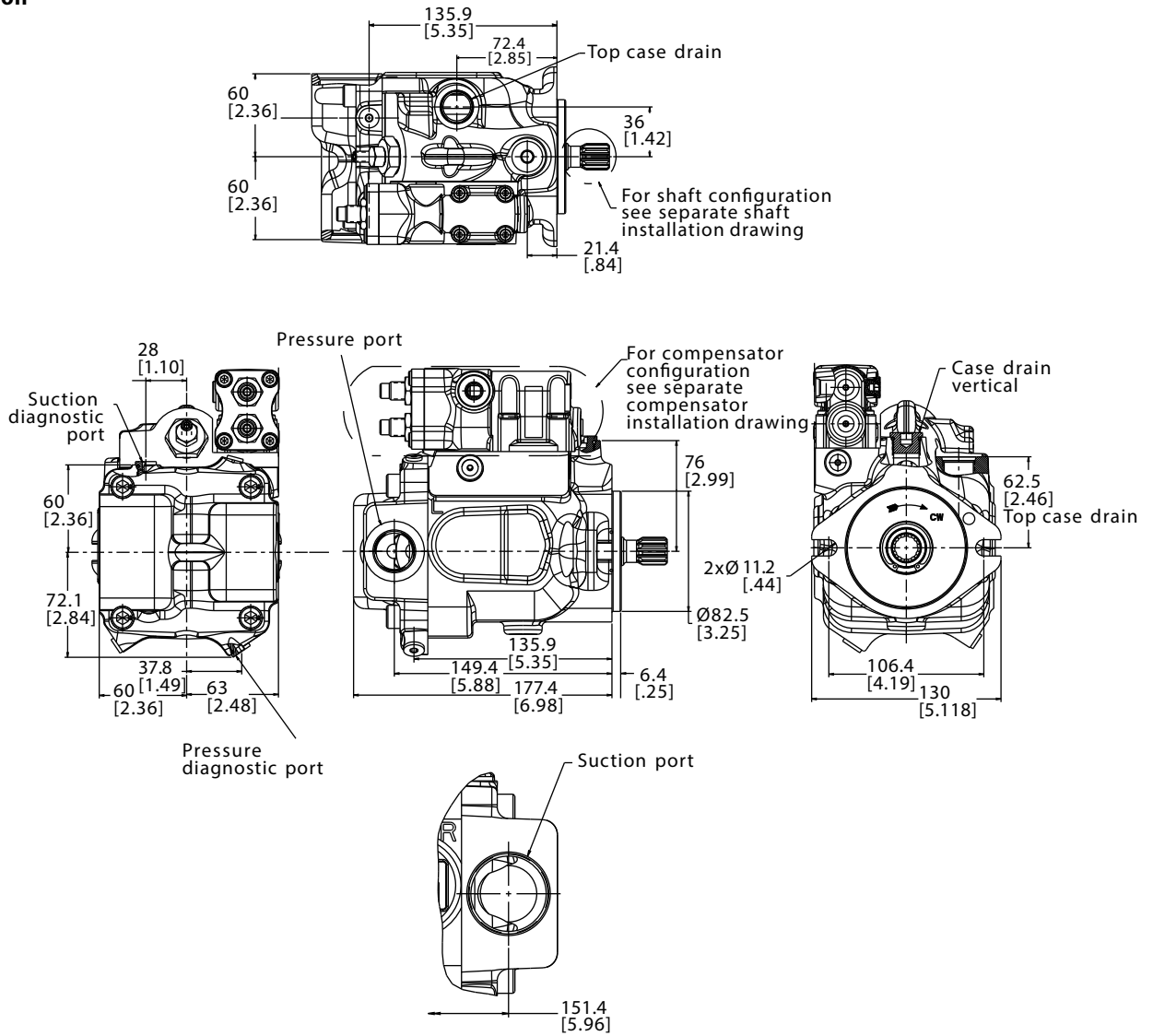

Pump installation

AEC018 A-Mount AG version - rear ported

RH Rotation

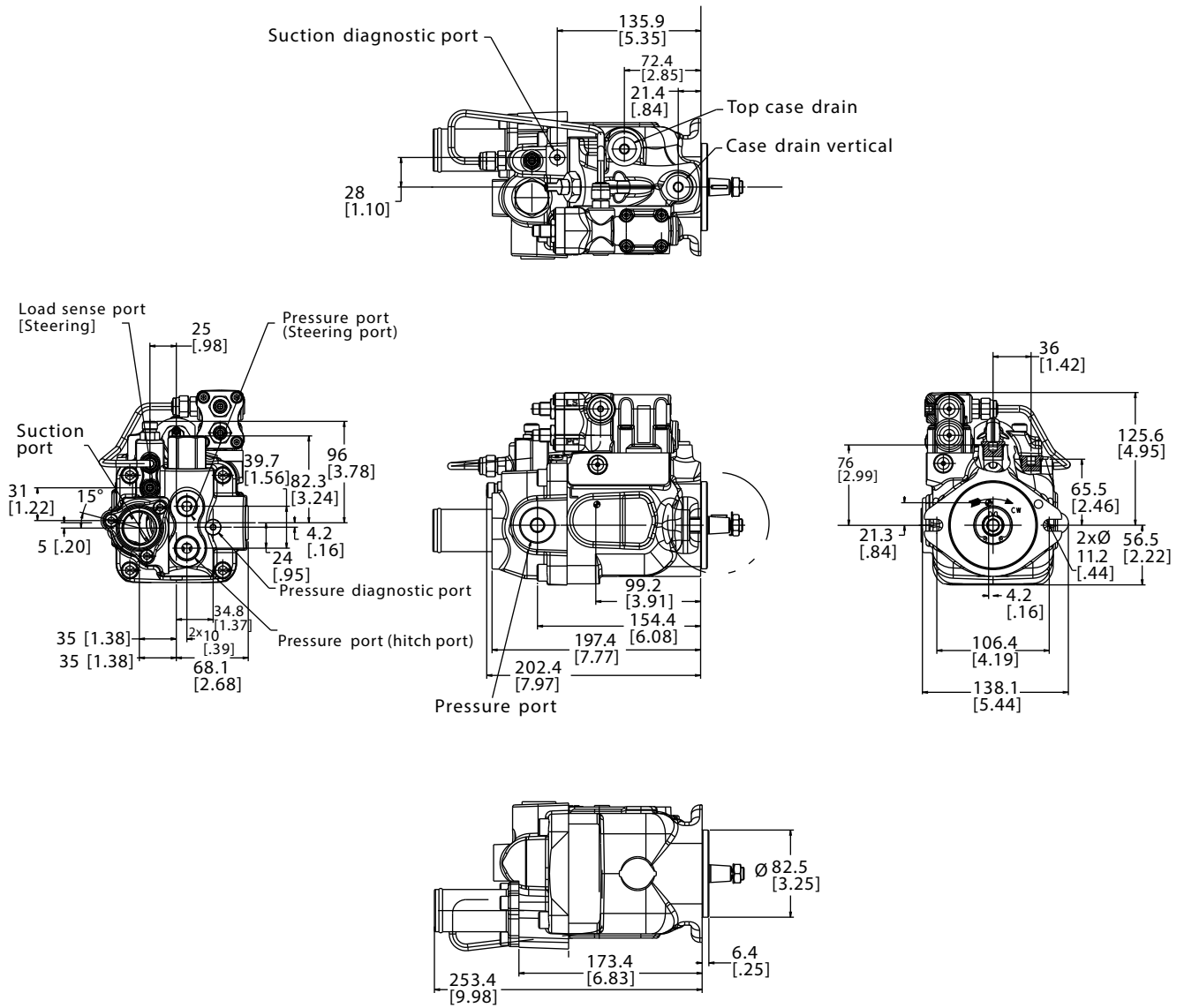

Pump installation

AEC028 B-Mount - rear-ported

RH Rotation

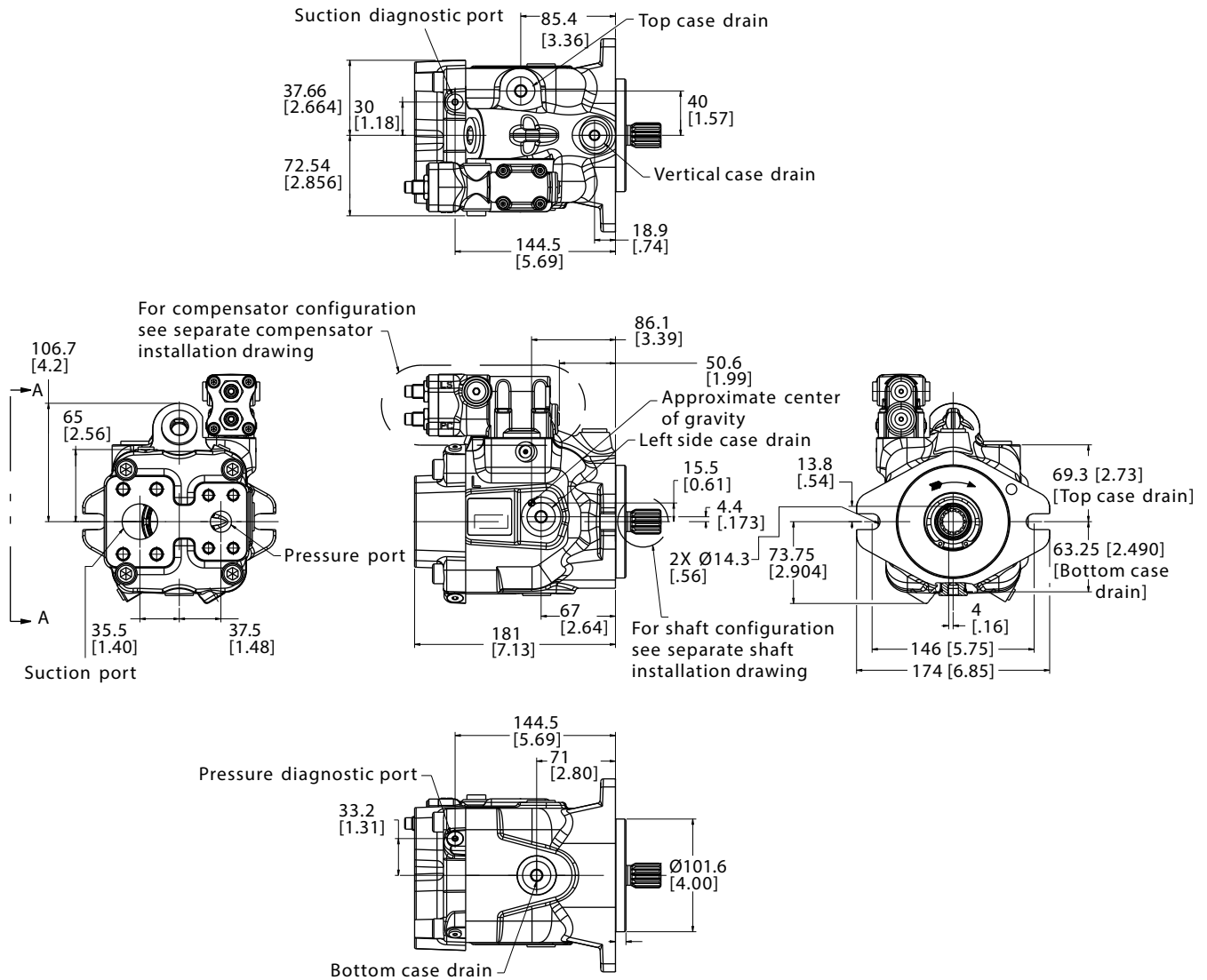

View A-A

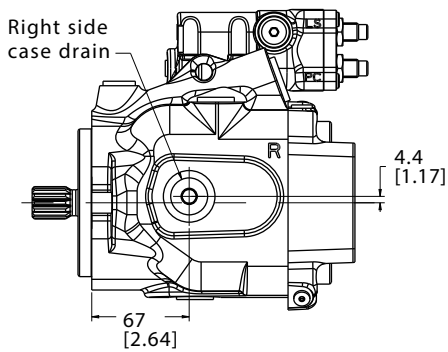

LH Rotation

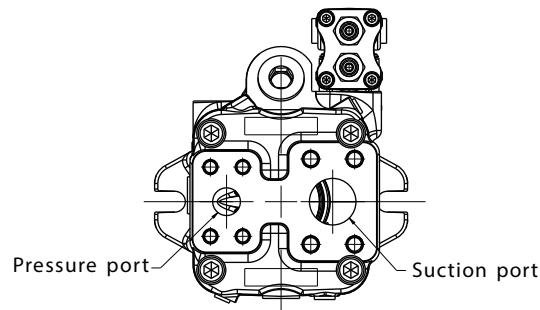

Pump installation

AEC028 B-Mount - side-ported

RH Rotation

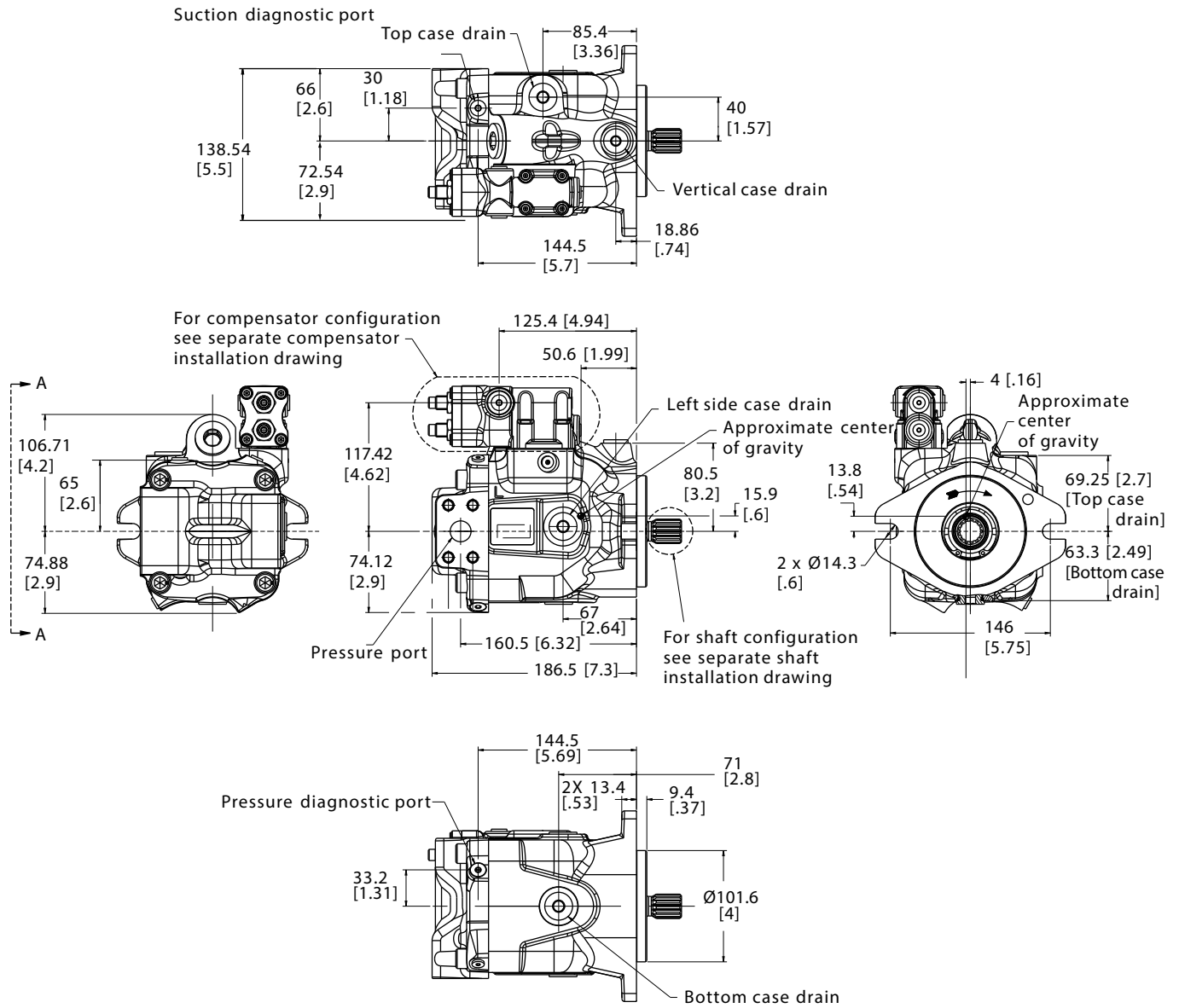

View A-A

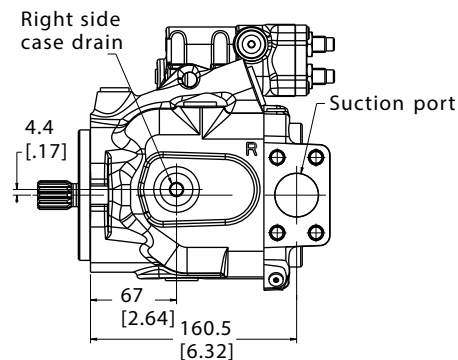

LH Rotation

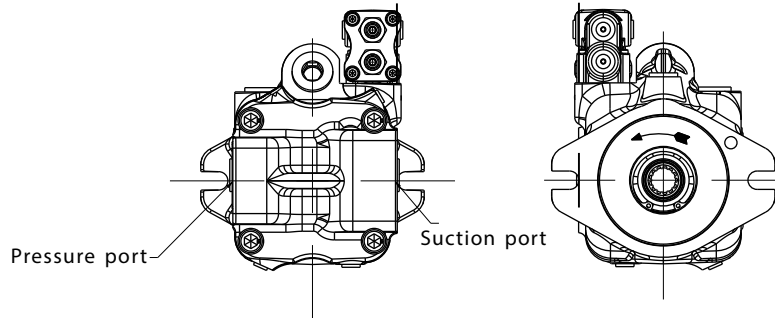

Pump installation

AEC028 Thru drive SAE-A

SAE-A mount

2-Bolt A mounting flange per SAE J744-82-2

Groove to accept an AS 568A size 152 O-ring

For output shaft configuration see separate shaft installation drawing

8X .375-16UNC - 2B ∇ 15.0

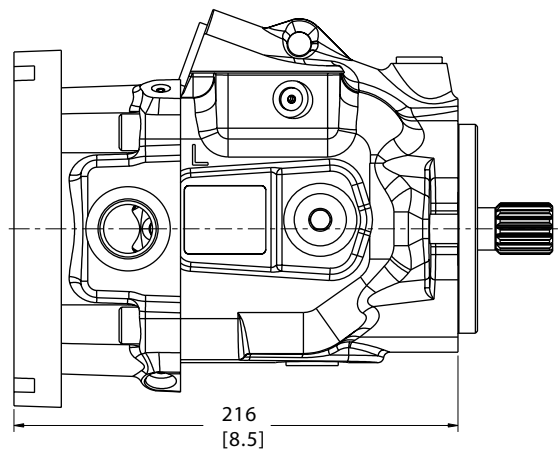
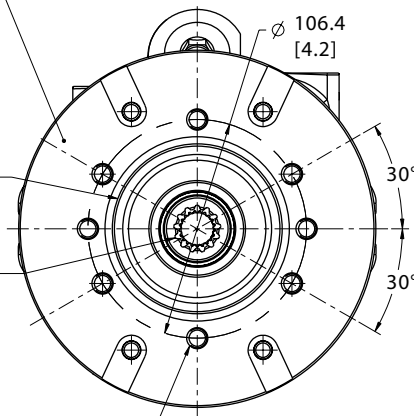

Output shaft installation AA- 9T spline

Max Torque 91 Nm (805 lbf-in)

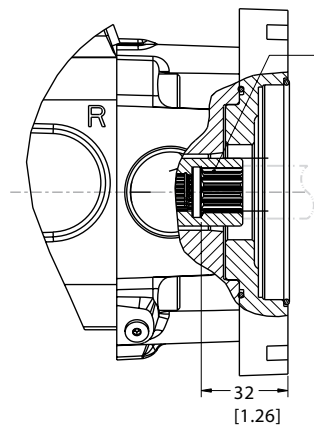

\varnothing 16.54 [.651] 9 tooth 30° flat root side fit 16/32 class 6 per ANS I B92.1-1996

Accepts 9 tooth 16/32 pitch flat root side fit involute spline per SAE J744-16-4

Additional unit driven by this spline must not require more than 91 Nm (805 lbf-in) of Torque

Output shaft installation AB- 11T spline

Max Torque 172 Nm (1522 lbf-in)

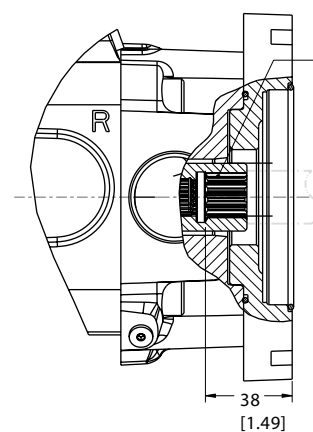

\varnothing 19.71 [.776] 11 tooth 30° flat root side fit 16/32 class 6 per ANS I B92.1-1996

Accepts 11 tooth 16/32 pitch flat root side fit involute spline per SAE J744-16-4.

Additional unit driven by this spline must not require more than 172 Nm (1522 lbf-in) of Torque

Pump installation

AECO28 Thru drive SAE-B

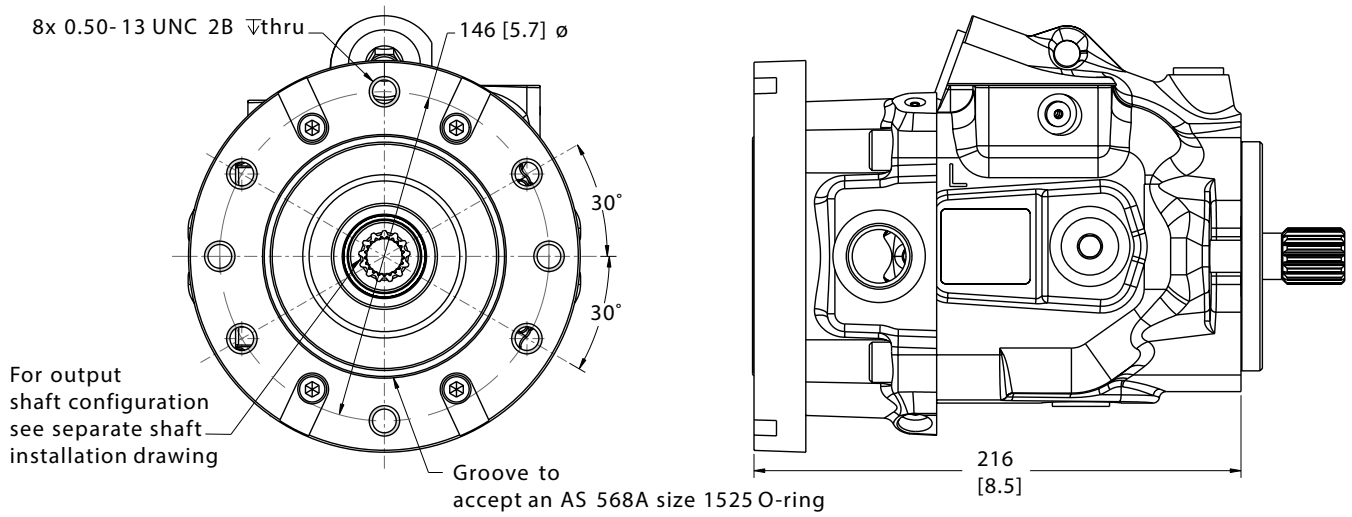

AC - 13T spline

Max Torque 252 Nm (2230 lbf-in)

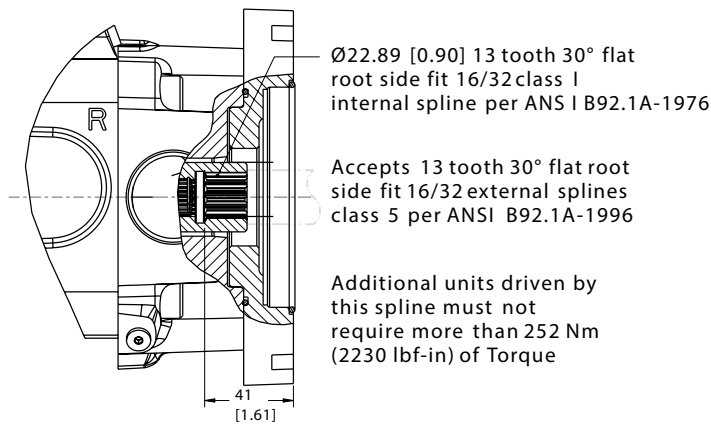

Thru drive cover plate information

AG - Auxiliary mount ready with cover plate

Cover plate

Fits on 220-SAE "A" type auxiliary mounting end cover

Cover Plate Kit # 9901110-000; includes
O-ring, Cover Plate, Cap Screws (2)

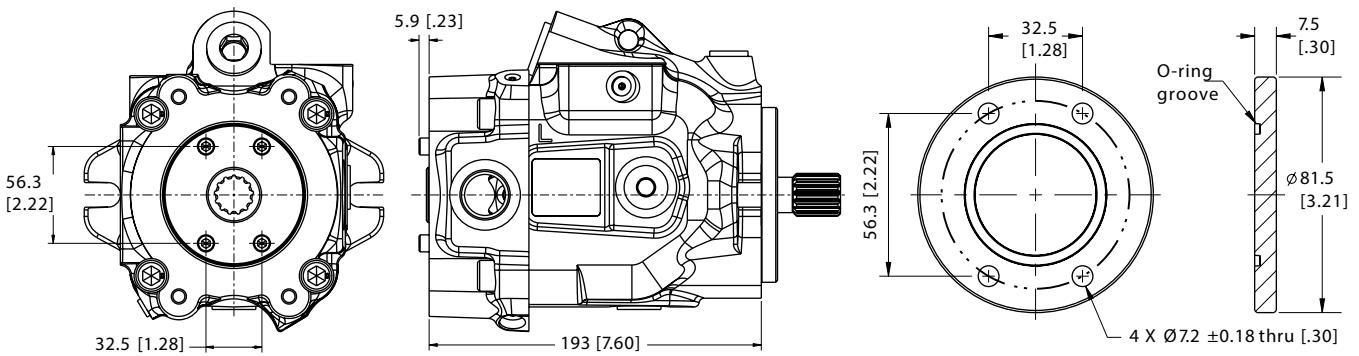

Control Installation

AEC018- Pressure & Flow (Load Sense) Compensator

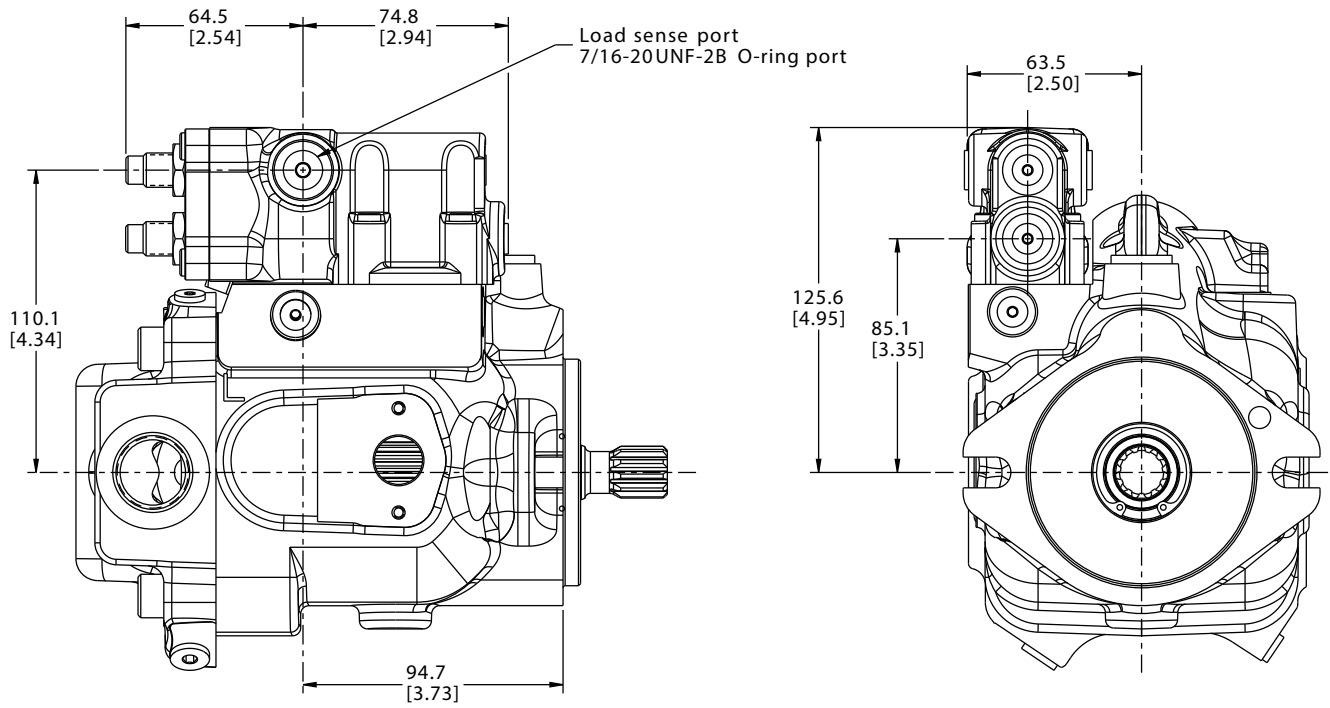

Control Installation

AEC-028 Pressure & Flow (Load Sense) Compensator

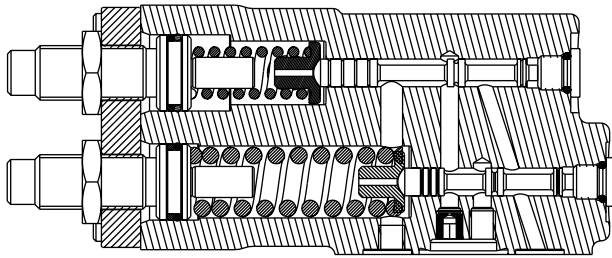
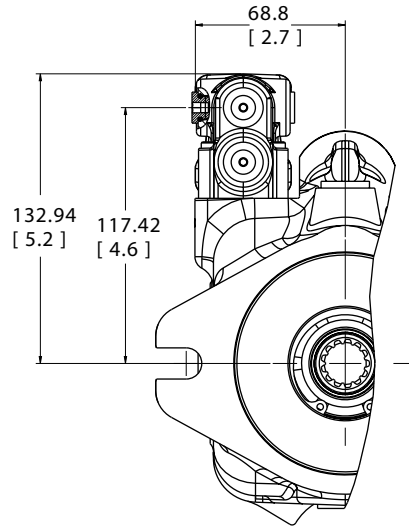
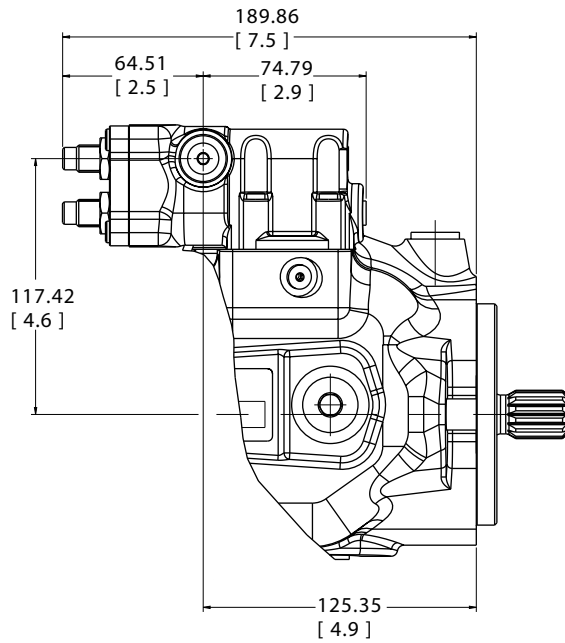

Pressure Compensator Control

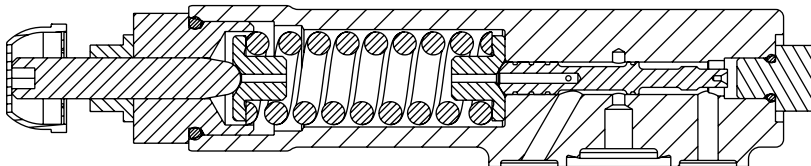
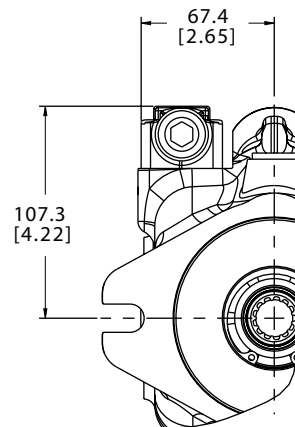
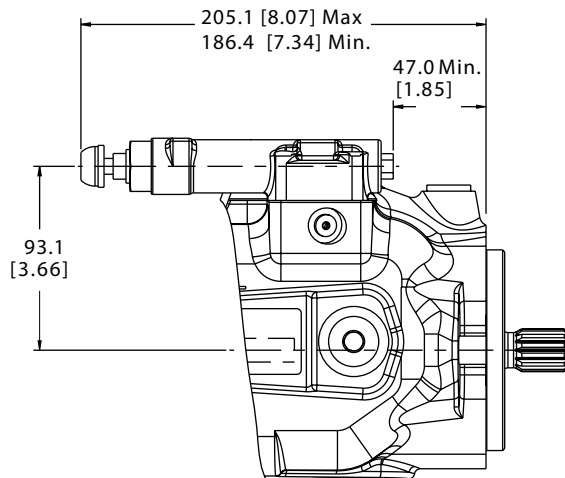

Control Installation

ACE028- Electronic Displacement Control(EDC)

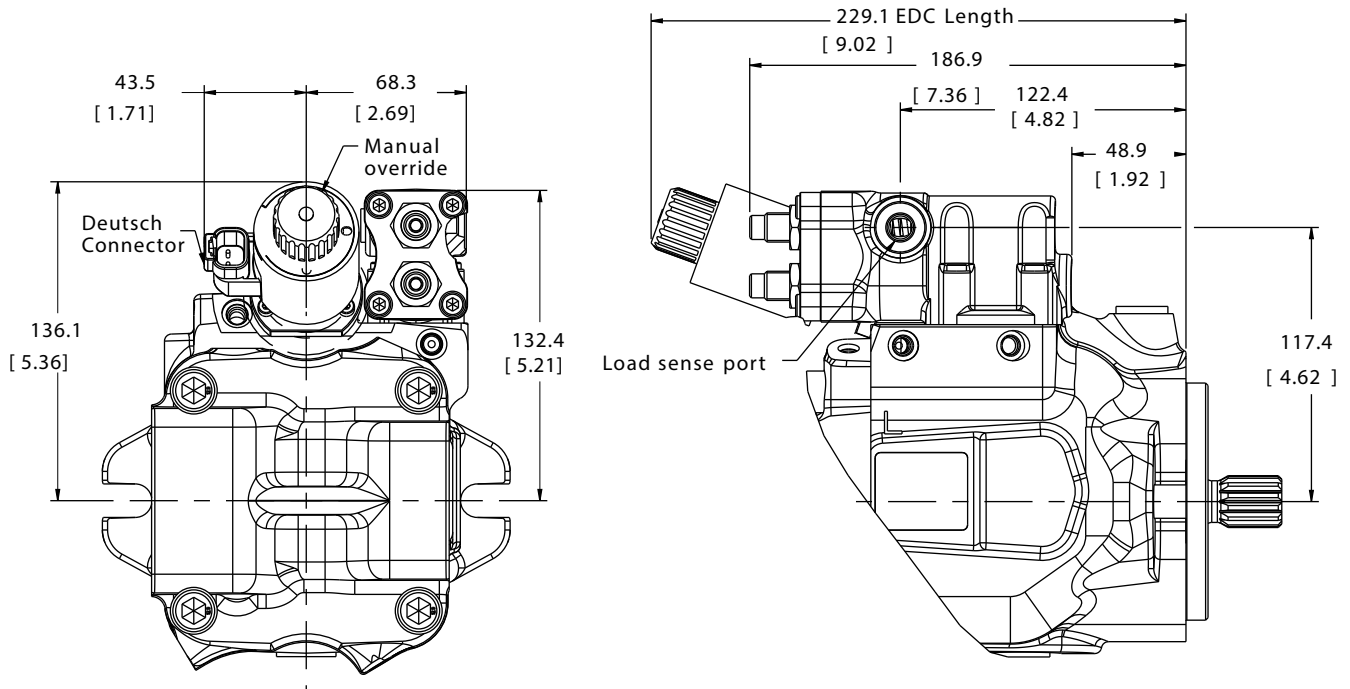

EH Inverse Proportional Pressure Control (IPPC)

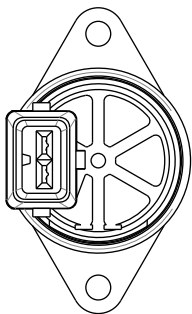
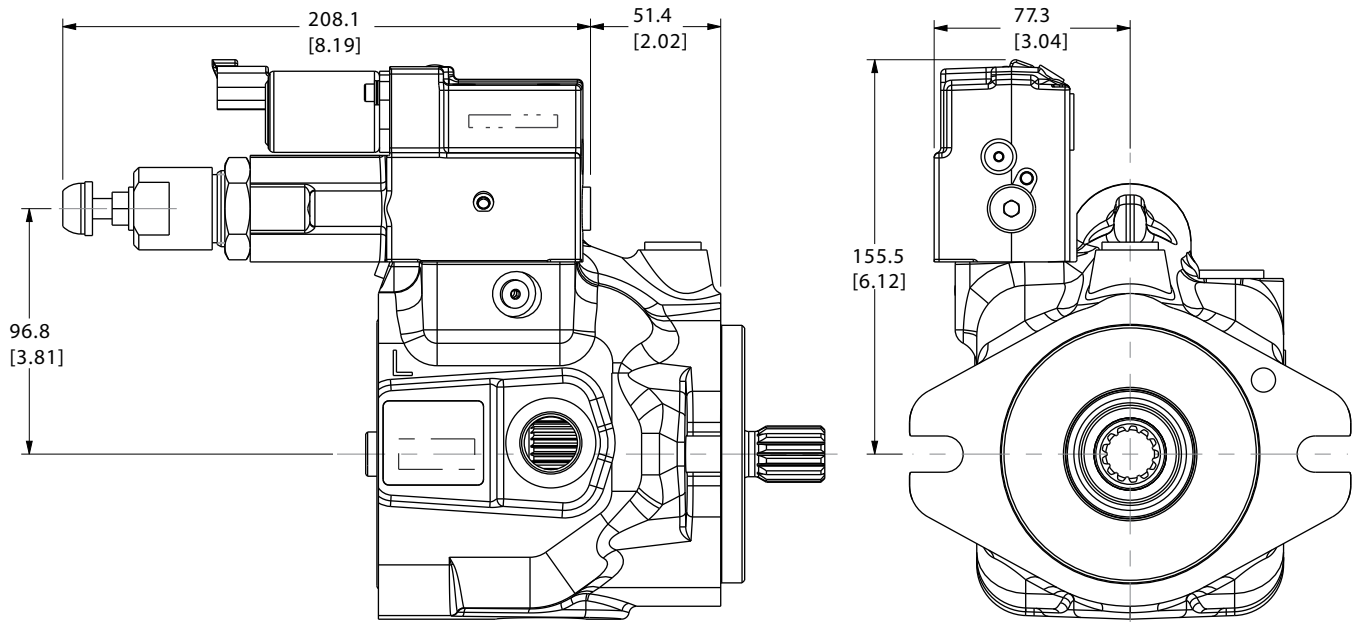

Amp connector option

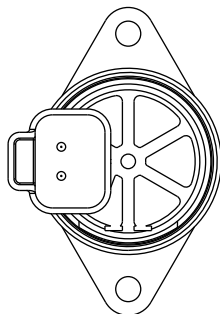

Deutsch connector option

External Manual Stroke Adjustment

AEC018 Maximum Stroke Limiter

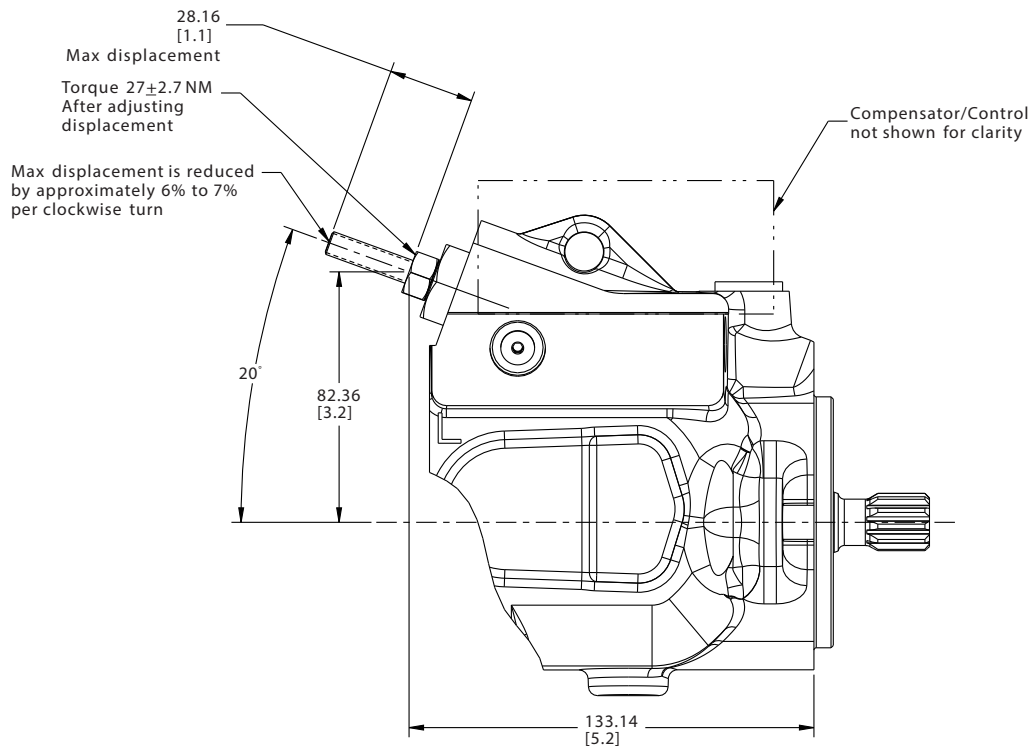

AEC028 Maximum Stroke Limiter

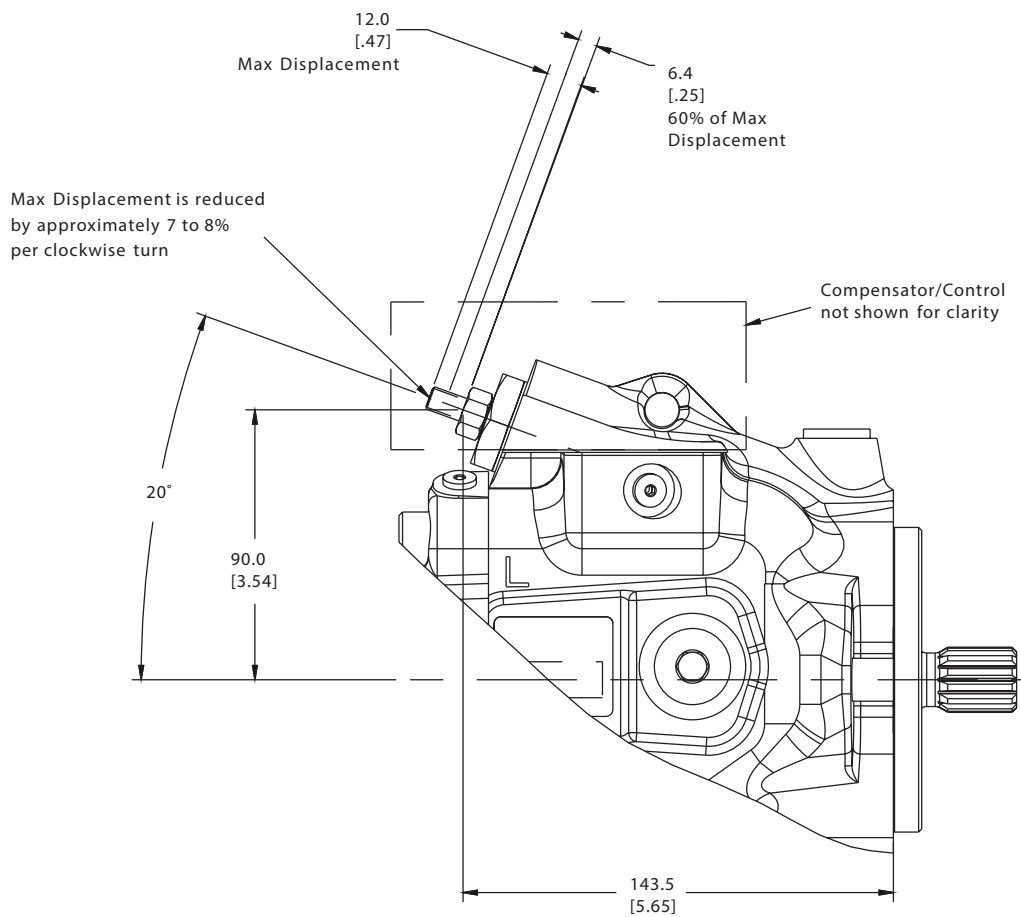



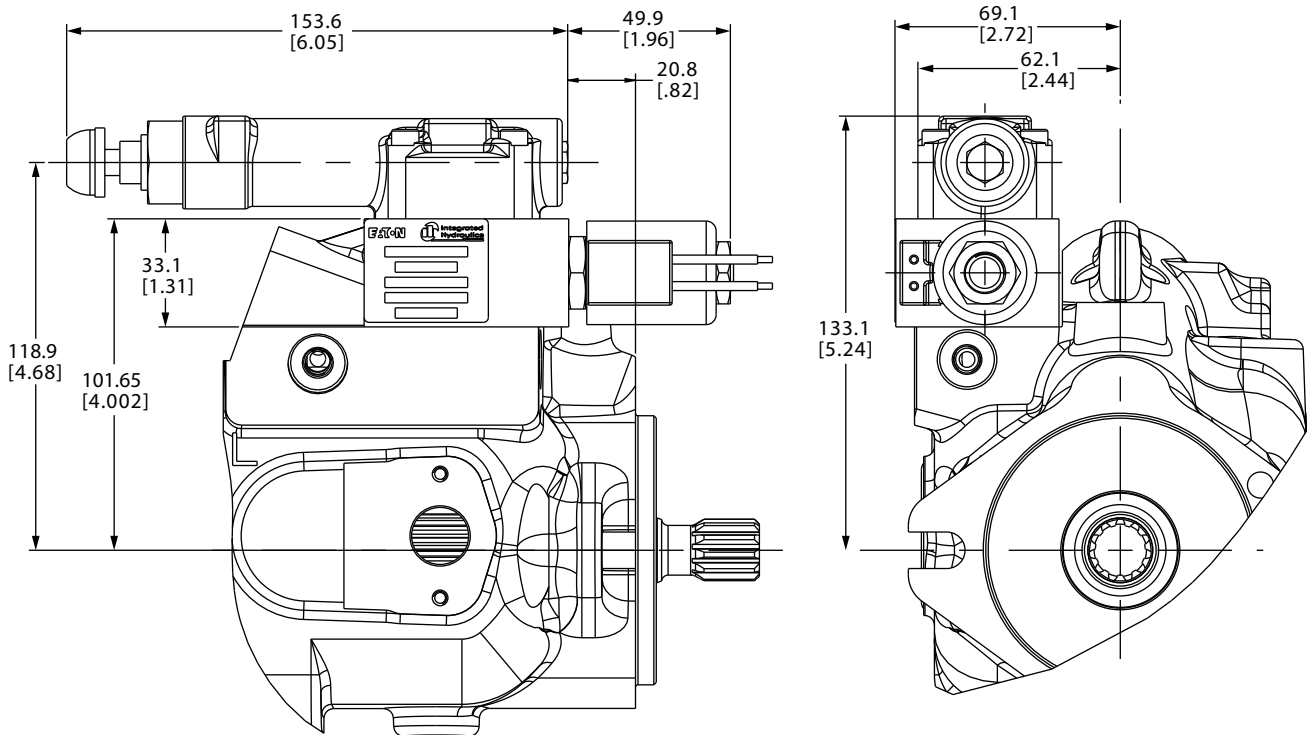

Cold start valve

AEC018 Cold start valve

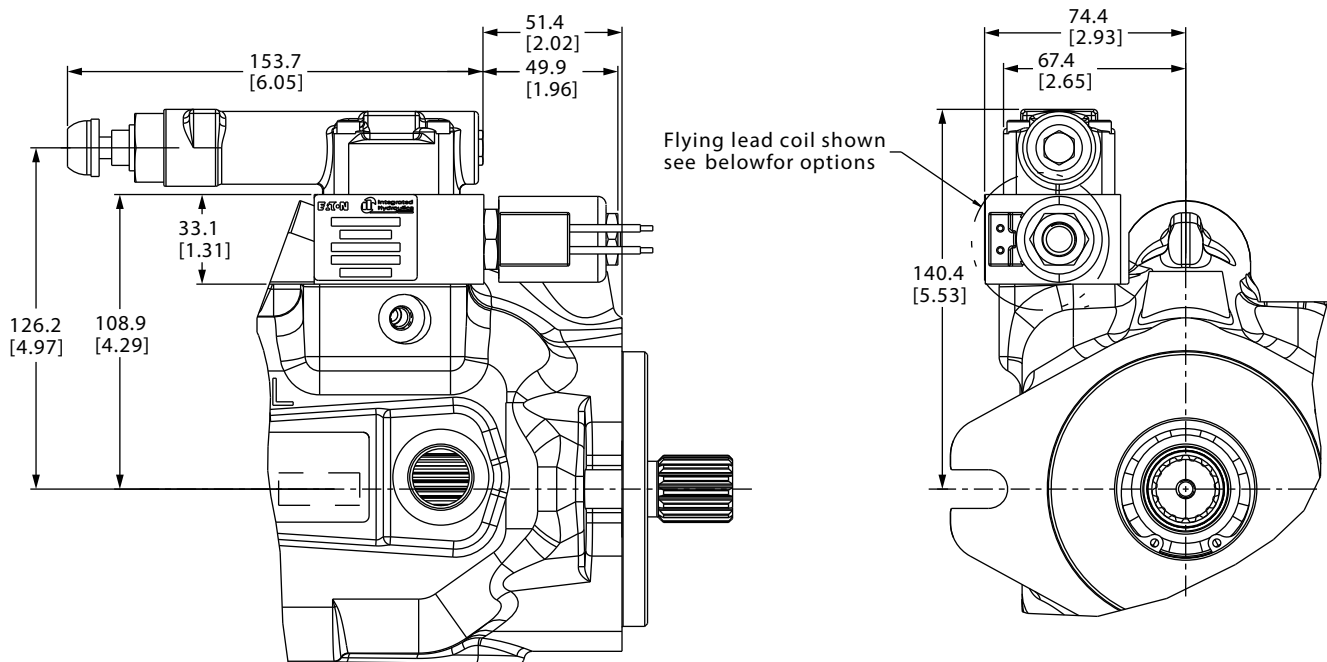

AEC028 Cold start valve



- 
 Deutsch option
- 
 Metri - pack 280 option
- 
 Metri - pack 150 option
- 
 DIN 43650 - A option

Input shaft options

05 Code

Maximum Torque
209.3 Nm [1852 in-lbf]

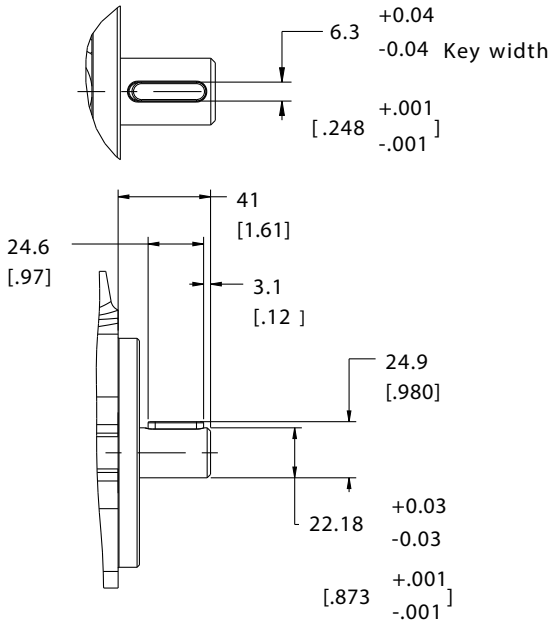

09 Code

Maximum Torque
209.3 Nm [1852 in-lbf]

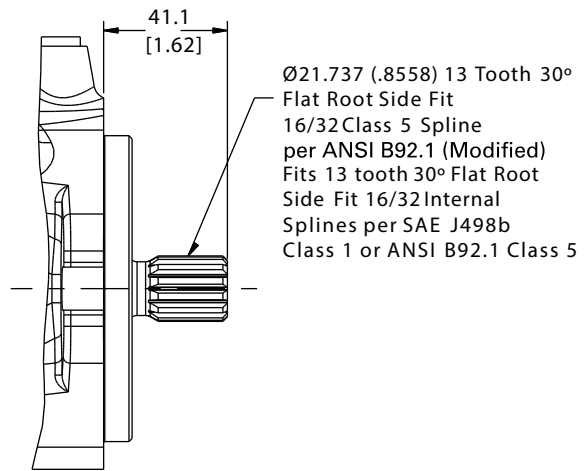

31 Code

Maximum Torque
337.5 Nm [2987 in-lbf]

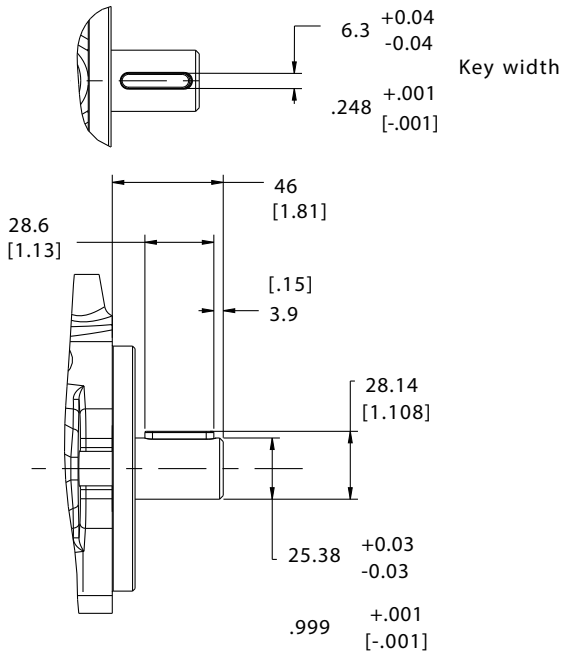

34 Code

Maximum Torque
337.5 Nm [2987 in-lbf]

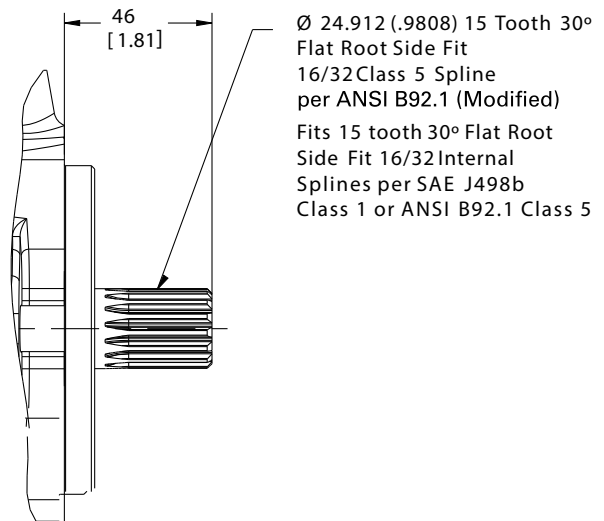

Input shaft options

48 Code

Maximum Torque
134 Nm [1186 in-lbf]

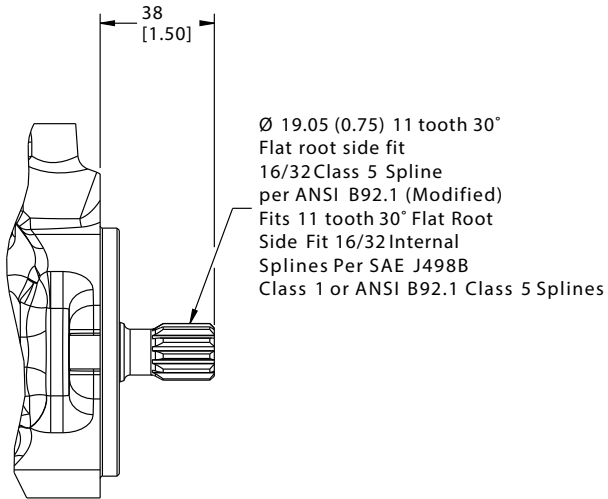

49 Code (for AG Variant only)

Maximum Torque
100 N-m [885 in-lbf]

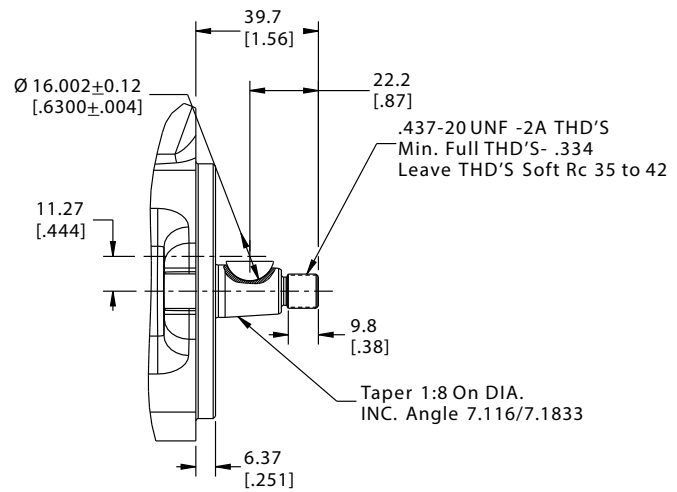

50 Code

Maximum Torque
100 N-m [885 in-lbf]

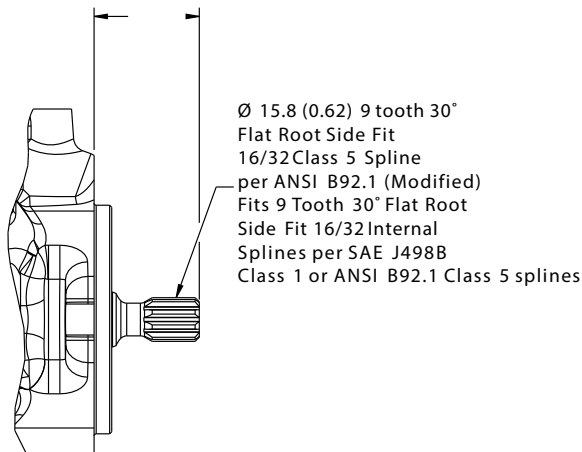

51 Code

Maximum Torque
134 Nm [1186 in-lbf]

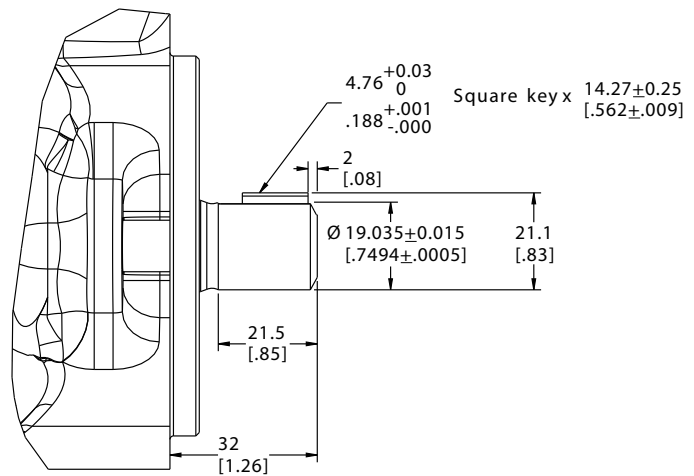

52 Code

Maximum Torque
100 N-m [885 in-lbf]

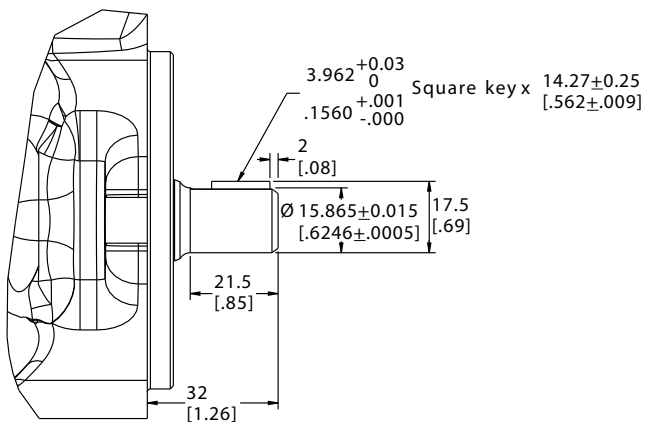

Installation and start-up

Warning: Care should be taken that mechanical and hydraulic resonances are avoided in the application of the pump. Such resonances can seriously compromise the life and/or safe operation of the pump.

Drive data

Mounting attitude should be horizontal (shaft parallel to the ground) using the appropriate case drain port (furthest from the ground) to ensure that the case remains full of fluid at all times. If mounted with shaft upward (shaft perpendicular to the ground) the shaft end case drain (option G or H) must be used.

In those cases where geometric tolerances of mounting are critical, or where specific tolerance ranges are required and not specified, consult Danfoss engineering for specific limits.

Direction of shaft rotation, viewed from the prime mover end, must be as indicated in the model designation on the pump—either right hand (clockwise) or left hand (counterclockwise).

Direct coaxial drive through a flexible coupling is recommended. If drives imposing radial shaft loads are considered, please consult your Danfoss representative.

Start-up procedure

Make sure the reservoir and circuit are clean and free of dirt/debris prior to filling with hydraulic fluid.

Fill the reservoir with filtered oil and fill to a level sufficient enough to prevent vortexing at the suction connection to pump inlet. It is good practice to clean the system by flushing and filtering, using an external slave pump.

Caution: Before the pump is started, fill the case through the uppermost drain port with hydraulic fluid of the type to be used. The case drain line must be connected directly to the reservoir and must terminate below the oil level.

Once the pump is started, it should prime within a few seconds. If the pump does not prime, check to make sure that there are no restrictions between the reservoir and the inlet to the pump, and that the pump is being rotated in the proper direction, and that there are no air leaks in the inlet line and connections. Also check to make sure that trapped air can escape at the pump outlet.

After the pump is primed, tighten the loose outlet connections, then operate for five to ten minutes (unloaded) to remove all trapped air from the circuit.

If the reservoir has a sight gage, make sure the fluid is clear—not milky.

Fluid cleanliness

The X20 Series pumps are rated in anti-wear petroleum fluids with a contamination level of 21/18/13 per ISO 4406. Operation in fluids with levels more contaminated than this is not recommended. Fluids other than petroleum, severe service cycles, or temperature extremes are cause for adjustment of these codes. Please contact your Danfoss representative for specific duty cycle recommendation.

Danfoss X20 Series pumps, as with any variable displacement piston pumps, will operate with apparent satisfaction in fluids up to the rating specified here. Experience has shown however, that pump and hydraulic system life is not optimized with high fluid contamination levels (high ISO cleanliness codes).

Proper fluid condition is essential for long and satisfactory life of hydraulic components and systems. Hydraulic fluid must have the correct balance of cleanliness, materials, and additives for protection against wear of components, elevated viscosity and inclusion of air.

Essential information on the correct methods for treating hydraulic fluid is included in Danfoss publication 561 – “Guide to Systemic Contamination Control” – available from your local Danfoss distributor. In this publication, filtration and cleanliness levels for extending the life of axial piston pumps and other system components are listed. Included is an excellent discussion of the selection of products needed to control fluid condition.

Products we offer:

- Cartridge valves
- DCV directional control valves
- Electric converters
- Electric machines
- Electric motors
- Gear motors
- Gear pumps
- Hydraulic integrated circuits (HICs)
- Hydrostatic motors
- Hydrostatic pumps
- Orbital motors
- PLUS+1® controllers
- PLUS+1® displays
- PLUS+1® joysticks and pedals
- PLUS+1® operator interfaces
- PLUS+1® sensors
- PLUS+1® software
- PLUS+1® software services, support and training
- Position controls and sensors
- PVG proportional valves
- Steering components and systems
- Telematics

Danfoss Power Solutions is a global manufacturer and supplier of high-quality hydraulic and electric components. We specialize in providing state-of-the-art technology and solutions that excel in the harsh operating conditions of the mobile off-highway market as well as the marine sector. Building on our extensive applications expertise, we work closely with you to ensure exceptional performance for a broad range of applications. We help you and other customers around the world speed up system development, reduce costs and bring vehicles and vessels to market faster.

Danfoss Power Solutions – your strongest partner in mobile hydraulics and mobile electrification.

Go to www.danfoss.com for further product information.

We offer you expert worldwide support for ensuring the best possible solutions for outstanding performance. And with an extensive network of Global Service Partners, we also provide you with comprehensive global service for all of our components.

Local address:

Hydro-Gear

www.hydro-gear.com

Daikin-Sauer-Danfoss

www.daikin-sauer-danfoss.com

Danfoss Power Solutions (US) Company
2800 East 13th Street
Ames, IA 50010, USA
Phone: +1 515 239 6000

Danfoss Power Solutions GmbH & Co. OHG
Krokamp 35
D-24539 Neumünster, Germany
Phone: +49 4321 871 0

Danfoss Power Solutions ApS
Nordborgvej 81
DK-6430 Nordborg, Denmark
Phone: +45 7488 2222

Danfoss Power Solutions Trading (Shanghai) Co., Ltd.
Building #22, No. 1000 Jin Hai Rd
Jin Qiao, Pudong New District
Shanghai, China 201206
Phone: +86 21 2080 6201