

PM20

VARIABLE DISPLACEMENT PUMP CLOSED LOOP CIRCUIT



T E C H N I C A L C A T A L O G



OVERVIEW

PM20 is a variable displacement, axial piston pump, with swashplate system, for closed loop hydrostatic transmissions.

It provides a continuously variable flow rate between zero and maximum in forward and reverse direction. Flow rate is proportional to rotation speed and swashplate angle.

It can feature a charge pump to keep the circuit pressurised. This avoids risk of cavitations and ensures a good performance of the transmission.

It offers several types of control: servo mechanical, servo hydraulic, electro-proportional with or without feedback and hydraulic automotive.

It is equipped with high pressure relief valves and can be delivered with auxiliary gear pumps.

It is available in single or tandem versions.

As options, PM20 can be featured with roller bearing, customized identification plate, mechanical inching, filter on pressure line, external connections for filter, UNF thread ports, finishing coat, fluorinated elastomer seals, flushing valve, safety valve and anti-stall valve.

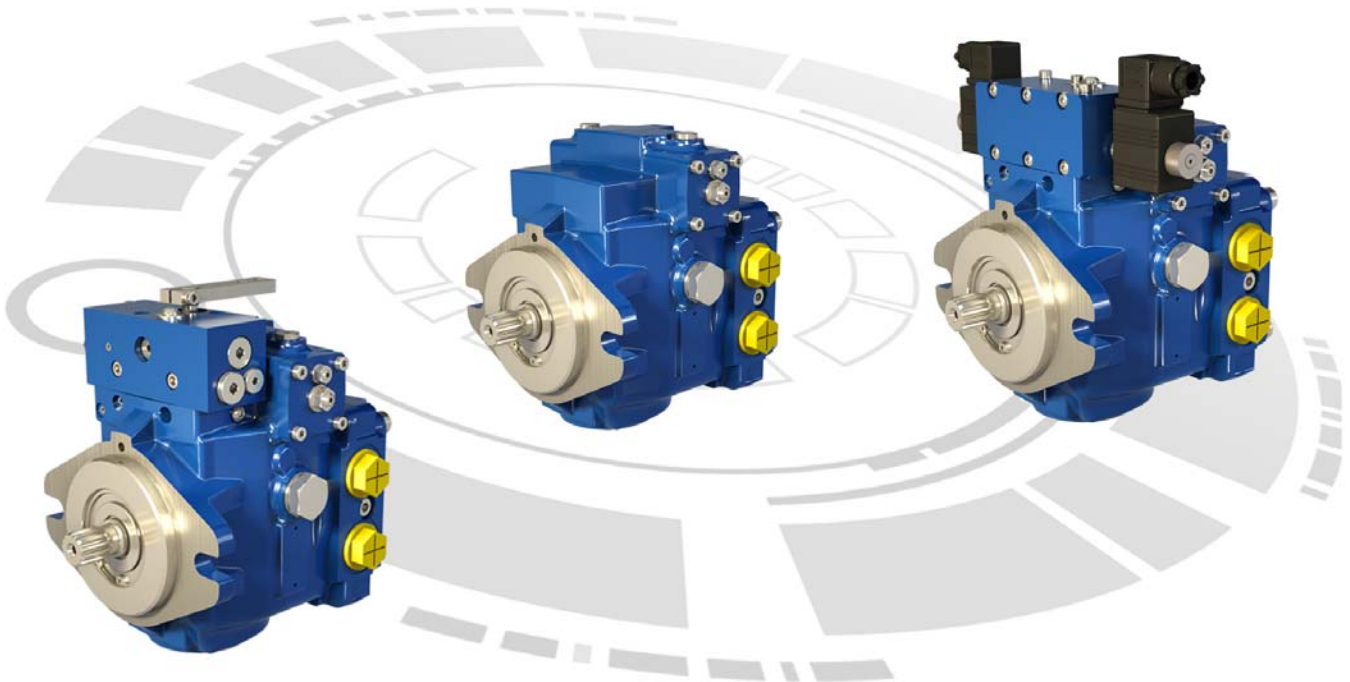

		PM20-21	PM20-25	PM20-28
Displacement	cm ³ /rev [in ³ /rev.]	21 [1.28]	25 [1.53]	27,36 [1.67]
Theoretical flow at full displacement and rated speed	L/min [GPM]	75,6 [20.0]	90,0 [23.8]	98,5 [26.0]
Rated speed	rpm	3 600		
Rated pressure	bar [PSI]	250 [3 625]		
Max. pressure	bar [PSI]	370 [5 366] *		
Mounting flange		SAE B		
Controls		Servo mechanical, Servo hydraulic, Hydraulic automotive, Electro-proportional with and without feedback		
Mass	kg [lb]	from 20 [44.1] to 23 [50.7]		
Rotation		Clockwise or Counterclockwise		

* Consult your Poclain Hydraulics application engineer.



CONTENT

MODEL CODE	4	→	Model Code
TECHNICAL SPECIFICATIONS	6		
Features	6	→	Technical specifications
Main dimensions	7		
Port characteristics	7		
OPERATING PARAMETERS	9	→	Operating Parameters
Operating parameters	9		
Charge pressure	9		
Case pressure	9		
Pressure ratings	9		
Speed ratings	9		
Inlet pressure	10		
Theoretical output	10		
Poclain Hydraulics recommendations for fluid	10		
Fluid and filtration	11		
Viscosity range	11		
SYSTEM DESIGN PARAMETERS	12	→	System design Parameters
Sizing equations	12		
Redundant braking system requirement	12		
Loop flushing	12		
Reservoir	13		
Case drain usage for tandem pump	13		
Differential pressure	13		
Bearing life and external shaft loading	14		
Hydraulic unit life	15		
Mounting flange loads	15		
FEATURES	16	→	Features
High pressure relief valve	16		
Charge relief valve	17		
Charge pump	18		
Displacement limiters	19		
By-pass	19		
Mounting flange and shafts	20		
Auxiliary mounting pad	21		
Tandem pumps	22		
Gear pumps	23		
CONTROLS	24	→	Controls
Mechanical servo control with feedback	24		
Hydraulic servo control	26		
Hydraulic automotive control	28		
Electro-proportional servo control	30		
Electro-proportional control with feedback	32		
OPTIONS	33	→	Options
Roller bearing	33		
Customized identification plate	33		
Mechanical inching	33		
Finishing coat	33		
Fluorinated elastomer seals	33		
Filter on pressure line	34		
External connections for filter	35		
UNF thread ports	35		
Flushing valve	35		
Safety valve	36		
Anti-stall valve	36		



MODEL



1

Displacement cm ³ /rev [in ³ /rev]	
21 [1.28]	21
25 [1.53]	25
27,36 [1.67]	28

2

Mounting flange and shaft	
Splined shaft (z = 13; 16/32 D.P.)	S3
SAE B Splined shaft (z = 15; 16/32 D.P.)	S4
Shaft for secondary tandem pump	T1

3

Control	
Mechanical servo control with feed back	A
Hydraulic servo control	S
Hydraulic automotive control 12V	D12
Hydraulic automotive control 24V	D24
Electro-proportional control 12V	P12
Electro-proportional control 24V	P24
Electro-proportional servo control 12V with feedback	Q12
Electro-proportional servo control 24V with feedback	Q24

4

K restrictor mm [in]	
Without restrictor	00
Ø 0,6 [dia. 0.023]	06
Ø 0,8 [dia. 0.031]	08
Ø 1,0 [dia. 0.047]	10

5

High pressure relief valve setting Max. system pressure (bar [PSI])	
Without valve (only check valve)	00
150 [2 175]	15
200 [2 900]	20
250 [3 625]	25
300 [4 351]	30
350 [5 076]	35
370 [5 366] *	37

* Consult your Poclain Hydraulics application engineer.



CODE

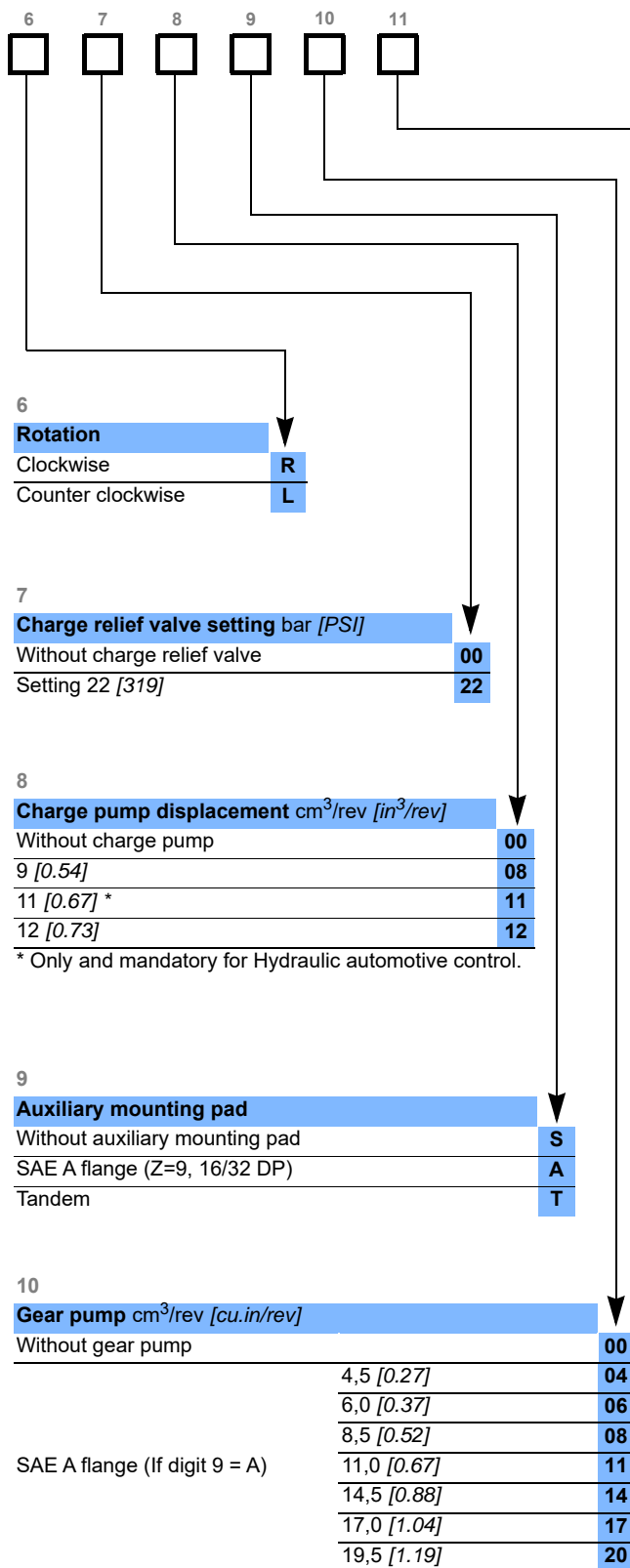

6

Rotation	
Clockwise	R
Counter clockwise	L

7

Charge relief valve setting bar [PSI]	
Without charge relief valve	00
Setting 22 [319]	22

8

Charge pump displacement cm ³ /rev [in ³ /rev]	
Without charge pump	00
9 [0.54]	08
11 [0.67] *	11
12 [0.73]	12

* Only and mandatory for Hydraulic automotive control.

9

Auxiliary mounting pad	
Without auxiliary mounting pad	S
SAE A flange (Z=9, 16/32 DP)	A
Tandem	T

10

Gear pump cm ³ /rev [cu.in/rev]		
Without gear pump	00	
4,5 [0.27]	04	
6,0 [0.37]	06	
8,5 [0.52]	08	
SAE A flange (If digit 9 = A)	11,0 [0.67]	11
	14,5 [0.88]	14
	17,0 [1.04]	17
	19,5 [1.19]	20

11

Options	
Without option	00
Roller bearing	CR
Customized identification plate	DP
Mechanical inching	IC
Filter on pressure line without clogging indicator	F0
Filter on pressure line with clogging indicator	F2
External connections for filter	F3
UNF thread ports	FU
Pressure cut-off valve	LP
Neutral position switch for A control	MI
Antistall valve	SD
Finishing coat	PA
Fluorinated elastomer seals	EV
Flushing valve	VS
Safety valve	VPU
Special version	ES

 In case of request for a combination of several options, please contact your Poclain Hydraulics application engineer for further information.

Model Code

Technical specifications

Operating Parameters

System design Parameters

Features

Controls

Options



TECHNICAL SPECIFICATIONS

Features

		PM20-21	PM20-25	PM20-28
Displacement	cm ³ /rev [in ³ /rev.]	21 [1.28]	25 [1.53]	27,36 [1.67]
Theoretical flow at full displacement and rated speed (3600 rpm)	L/min [GPM]	75,6 [20.0]	90,0 [23.8]	98,6 [26.0]
Max. theoretical absorbed power at rated speed and full displacement, $\Delta p=250$ bar [3 625 PSI]	kW [hp]	31,5 [42.2]	37,5 [50.2]	41,1 [55.1]
Theoretical absorbed torque at full displacement $\Delta p=250$ bar [3 625 PSI]	N.m [in.lbf]	83,6 [740]	99,5 [881]	109,0 [965]
Moment of inertia	kg.m ² [slug.ft ²]	0.0013 [0.0009]		
Internal charge pump	cm ³ /rev [in ³ /rev.]	9,1 [0.55] or 12 [0.73] or 11 [0.67] for automotive		
Charge relief valve setting	bar [PSI]	22 [319]		
High pressure relief valve setting	bar [PSI]	max. 370 [5 366] *		
Mounting flange		SAE B		
Mass	kg [lb]	20 [44.1] with control S 23 [50.7] with controls A, D, P, Q		

* Consult your Poclairn Hydraulics application engineer.



Main dimensions

PM20 with hydraulic servo control and without auxiliary mounting pad.

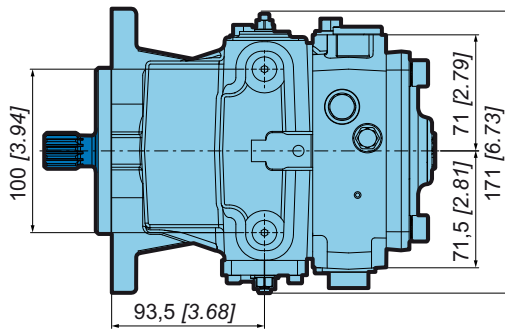
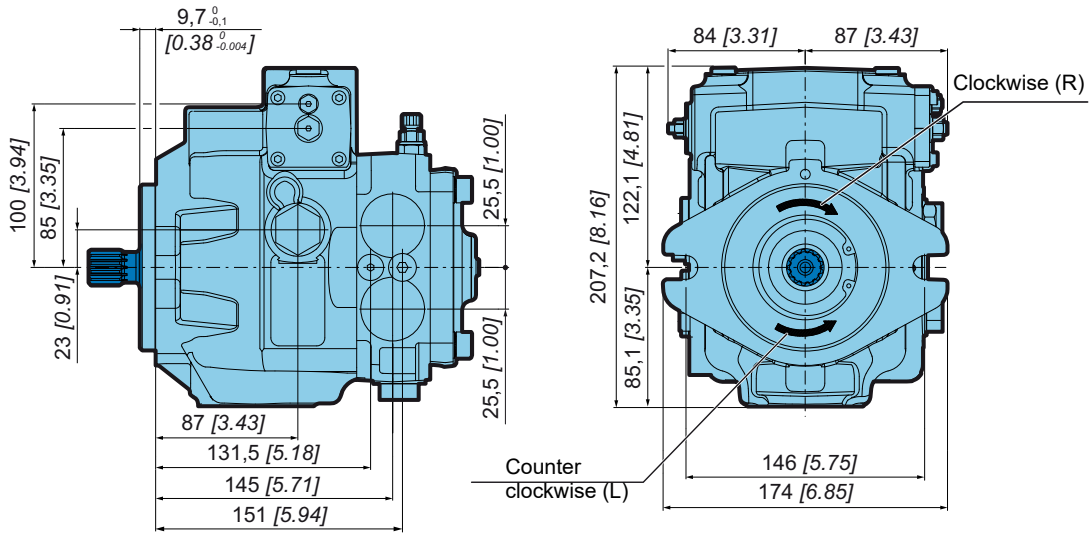

See from page 18 to page 32 for control dimensions.

Port characteristics

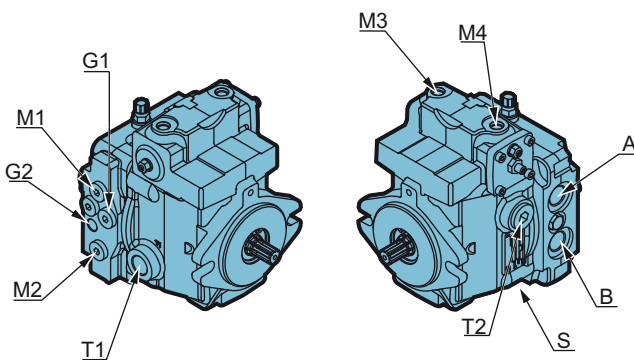

Port	Function	ISO 1179-1 (standard)	ISO 11926-1 (option FU)
A-B	Services	3/4" GAS	1-1/16-12 UNF-2B
G1	Auxiliary	1/4" GAS	9/16-18 UNF-2B
M1/M2	Gauge	1/4" GAS	9/16-18 UNF-2B
M3/M4	Servo control pilot	1/8" GAS	7/16-20 UNF-2B
S	Suction	3/4" GAS	1-1/16-12 UNF-2B
T1	Drain	1/2" GAS	1/2" GAS
T2	Drain	1/2" GAS	7/8-14 UNF-2B
G2	Auxiliary	3/8" GAS	3/8" GAS





OPERATING PARAMETERS

Operating parameters

		PM20-20	PM20-25	PM20-28
Speed ratings	Minimum		700	
	Max. without load	min ⁻¹ (rpm)	3 900 *	
	Max. with load		3 600	
System pressure	Rated		250 [3 625]	
	Maximum	bar [PSI]	370 [5 366] **	
	Minimum low loop		10 [145]	
Inlet pressure	Mini continuous	bar (abs.)	0,8 [11.6]	
	Mini (cold start)	[PSI abs.]	0,5 [7.2]	
Case pressure	Continuous	bar [PSI]	1,5 [21.7]	
	Maximum (cold start)		2,5 [36.2]	
Charge pressure	Standard version	bar [PSI]	22 [319]	
	Max. charge pressure		30 [435]	
Servo case pressure	Maximum	bar [PSI]	30 [435]	

* D control: max. speed limit 3 600 rpm, with or without load.
 ** Consult your Poclain Hydraulics application engineer.

Charge pressure

A charge flow is required to maintain a positive pressure in the low pressure loop of a closed loop hydrostatic transmission. Charge pressure ensures proper lubrication and rotating group operation. It is recommended to maintain the charge pressure at a minimum of 6 bar [87 psi] above case pressure. For more details, refer to charge pump paragraph, page 18.

Case pressure

Case pressure must be maintained within the limits shown in the table "Operating parameters". Ensure housing is always filled with hydraulic fluid, especially during start-up of the machine.

Pressure ratings

Maximum peak pressure

It is the maximum allowable pressure. It is equivalent to the maximum setting of the maximum high pressure relief valve. A self-propelled machine can reach the maximum peak pressure value no more than 1-2% of that work cycle.

Work cycle

A fundamental factor for ensuring correct hydrostatic transmission sizing is the machine work cycle (pressure-time ratio, seasonality, pressure vs. percentage of time at max. displacement, machine type). Part service life depends on the correct choice in relation to the work cycle.

Overloads

It is mandatory to protect parts against any possible overloads.

Speed ratings

The table "Operating parameters" gives minimum and maximum rated speeds. Note that all displacements might operate under different speed limits. Definitions of these speed limits appear below.

Maximum speed is the highest operating speed allowed. Over speeding reduces pump life time, can lead to loss of hydrostatic power and braking capacity. Never exceed the maximum speed limit under any operating conditions.

Nominal speed is the speed offering the maximal efficiency.

Model Code

Technical specifications

Operating Parameters

System design Parameters

Features

Controls

Options



Inlet pressure

Charge pump inlet pressure is key for acceptable pump life and performances. A continuous inlet pressure of not less than 0,8 bar abs. [11.6 PSI abs.] is recommended. An continuous inlet pressure less than 0.5 bar abs. [7.2 PSI abs.] indicates inadequate inlet design or a restricted filter. Pressures less than 0.5 bar abs. [7.2 PSI abs.] can happen at cold start, but should increase with oil temperature.

Theoretical output

Theoretical output flow is a function of pump displacement and speed. It is relevant to size the rest of the circuit. Theoretical flow does not take into account losses due to leakage or variations in displacement. Refer to performances, page 6, for volumetric and overall efficiencies at various operating speeds and pressures.

Poclain Hydraulics recommendations for fluid



Poclain hydraulics recommends the use of hydraulic fluids defined by the ISO 15380 and ISO 6743-4 standards. For temperate climates, the following types are recommended.

- HM 46 or HM 68 for fixed installations.
- HV 46 or HV 68 for mobile installations.
- HEES 46 for mobile installations.

These specifications correspond to category 91H of the CETOP standard, parts 1, 2 and 3 of the DIN 51524 standard, and grades VG32, VG 46 and VG68 of the ISO 6743-4 standards.



It is also possible to use ATF, HD, HFB, HFC or HFD type hydraulic fluid upon Poclain Hydraulics specific approval of the components' operating conditions.

Standardized designations for the fluids

- **HM** : Mineral fluids having specific antioxidant, anticorrosion and antiwear properties (HLP equivalent to DIN 51524 parts 1 and 2).
- **HV** : HM mineral fluids providing improved temperature and viscosity properties (DIN 51524 part 3).
- **HEES** : Biodegradable fluids based on organic esters.



It is also possible to use a fluid that meets the biodegradability criteria and is compatible in the event of accidental food contact. The BIOHYDRAN FG 46 fluid designed by the company Total has undergone testing of its properties and performance on our test benches. Since this type of fluid has not yet been categorized, it is the responsibility of machine manufacturers to validate its compatibility with all of the components used in order to guarantee that the intended functions will be fulfilled and this for the desired life time of all equipment items.



For biodegradable fluids, consult your Poclain Hydraulics' application engineer



During operation, the temperature of the oil must be between 0°C [32°F] and 80°C [176°F]; the minimum and maximum temperatures may be exceeded momentarily by ± 20°C [+68°/-4° F] for a duration of less than 30 minutes.

For all applications outside these limits, please consult with your Poclain Hydraulics' application engineer.

Pump storage



If the pump remains on stock for more than 6 months, a status verification must be performed before you install it on a machine. Pay attention to sealing condition, rust presence and free rotation of shaft.



Fluid and filtration

The contaminating particles suspended in the hydraulic fluid cause the hydraulic mechanisms moving part wear. On hydraulic pumps, these parts operate with very small dimensional tolerances. In order to reach the part life, it is recommended to use a filter that maintains the hydraulic fluid contamination class at a max. of:

- 6 according to NAS 1638
- 17/15/12 according to ISO 4406

According to the type of application decided for the pump, it is necessary to use filtration elements with a filtration ratio of:

$$\beta_{20 \text{ to } 30} \geq 100$$

Making sure that this ratio does not worsen together with the increasing of the filter cartridge differential pressure.

If these values cannot be observed, the component life will consequently be reduced and it is recommended to contact the Poclain Hydraulics Customer Service.

Filters on charge circuit

Filters on the charge circuit (F0-F2) are designed without by-pass. The max. pressure drop on the filtration part must not exceed 2 bar [29 PSI] (3 bar [43.5 PSI] in case of cold starting) at pump full rating. To monitor the pressure drop, it is recommended to use the clogging indicator on the filtration element (F2 option). Contact your Poclain Hydraulics Application engineer, each time the pump is not charged by its internal charge pump.

Filters on charge circuit are mounted on the pump special support.

Filters assembling

The suction filter is mounted on the suction line. Check that the pressure before the charge pump is 0.8 bar abs. [11.6 PSI abs.], measured on the pump suction port (0.5 bar [7.2 PSI] for cold starting).

Viscosity range

For both max. efficiency and life of the unit, the operative viscosity should be chosen within the optimum range of:

$\sqrt{\text{opt}}$ = optimum operating viscosity from 16 to 36 mm²/s [from 74.1 to 166.8 SUS] referred to the closed loop temperature.

Working conditions: the following limits of viscosity apply

$\sqrt{\text{min}}$ = 5 mm²/s [23 SUS] short-duration at a max. permissible leakage oil temperature of 90° C [194°F]

$\sqrt{\text{max}}$ = 1000 mm²/s [4 634 SUS] short-duration, on cold start.

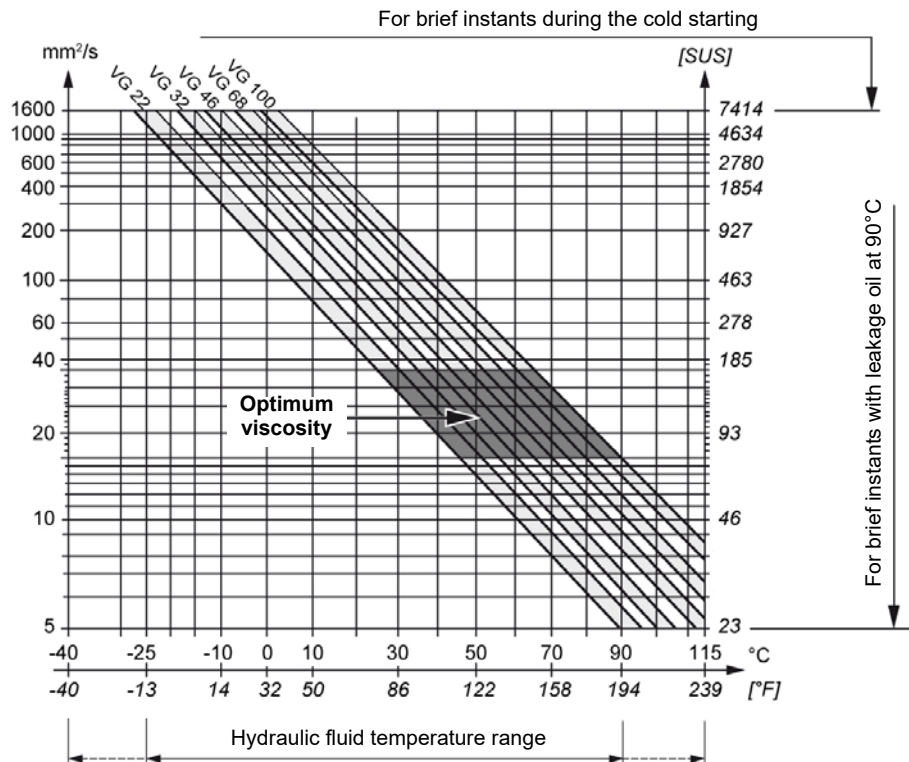

Ensure fluid temperature and viscosity limits are concurrently satisfied.

Model Code

Technical specifications

Operating Parameters

System design Parameters

Features

Controls

Options



SYSTEM DESIGN PARAMETERS



Consult your Poclain Hydraulics application engineer to validate your design parameters before using the pump in your application.

Sizing equations

The following equations are helpful when sizing hydraulic pumps. Generally, the sizing process is initiated by an evaluation of the machine system to determine the required motor speed and torque to perform the necessary work function. First, the motor is sized to transmit the maximum required torque. The pump is then selected as a flow source to achieve the maximum motor speed.

	Output flow Q	= $\frac{V_g \cdot n \cdot \eta_v}{1000}$	(l/min)
SI units	Input torque M	= $\frac{V_g \cdot \Delta p}{20 \cdot \pi \cdot \eta_m}$	(N.m)
	Input power P	= $\frac{M \cdot n \cdot \pi}{30\,000} = \frac{Q \cdot \Delta p}{600 \cdot \eta_t}$	(kW)
	Output flow Q	= $\frac{V_g \cdot n \cdot \eta_v}{231}$	[GPM]
US units	Input torque M	= $\frac{V_g \cdot \Delta p}{2 \cdot \pi \cdot \eta_m}$	[lbf.in]
	Input power P	= $\frac{M \cdot n \cdot \pi}{198\,000} = \frac{Q \cdot \Delta p}{1714 \cdot \eta_t}$	[hp]

V_g = Displacement per revolution cm^3/tr [in^3/rev]
 Δp = $p_o - p_i$ (system pressure) bar [PSI]
 n = Speed min^{-1} [rpm]
 η_v = Volumetric efficiency
 η_m = Mechanical efficiency
 η_t = Overall efficiency = $\eta_v \times \eta_m$

Redundant braking system requirement



Unintended vehicle or machine movement hazard.

The loss of hydrostatic drive line power, in any mode of operation (forward, neutral, or reverse) may cause the system to lose hydrostatic braking capacity. You must provide a braking system, redundant to the hydrostatic transmission, sufficient to stop and hold the vehicle or machine in the event of hydrostatic drive power loss.

Loop flushing

Closed circuit may require a flushing valve to meet temperature and cleanliness requirements. A flushing valve takes a part of hot fluid flow from the low pressure loop of the system loop for cooling and filtering. Make sure that the charge pump provides adequate flow for the flushing valve flushing and the flushing valve does not cause charge pressure to drop below recommended limits.

See option VS for more information

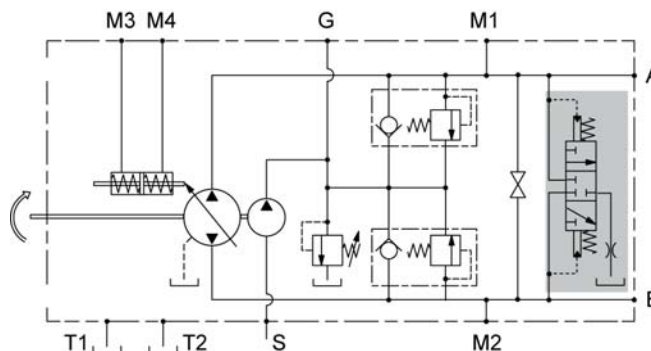



Reservoir

The reservoir provides clean fluid, dissipates heat, and removes entrained air from the hydraulic fluid. It allows for fluid volume changes associated with fluid expansion and cylinder differential volumes. Minimum reservoir capacity depends on the volume needed to perform these functions. Typically, a capacity of one half the charge pump flow (per minute) is satisfactory for a closed reservoir. Open circuit systems sharing a common reservoir require greater fluid capacity.

Locate the reservoir outlet (suction line) near the bottom, allowing clearance for settling foreign particles. Use a 100 - 125 µm screen covering the outlet port.

Place the reservoir inlet (return lines) below the lowest expected fluid level, as far away from the outlet as possible.

Use a baffle (or baffles) between the reservoir inlet and outlet ports to promote de-aeration and reduce fluid surging.

Case drain usage for tandem pump

On tandem pumps, and to ensure lubrication of both pumps, excess flow from the first pump charge relief valve must be routed into the housing of the second pump and viceversa.

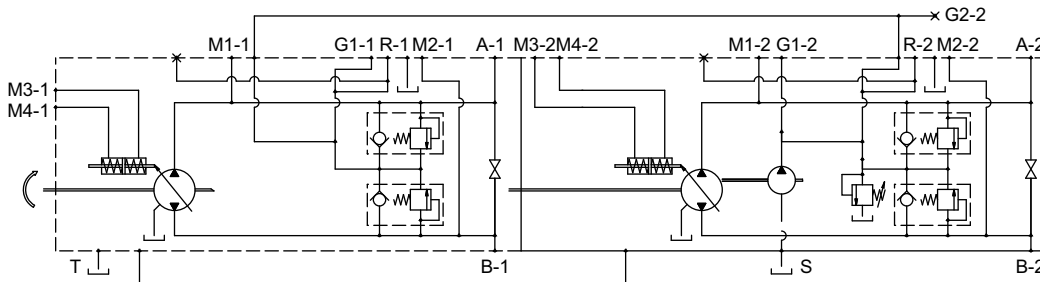

Differential pressure

The differential pressure is the High pressure relief valve setting minus Charge relief valve setting.

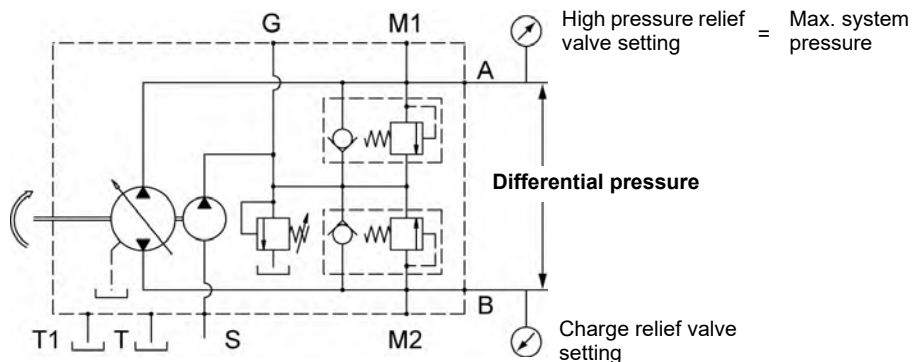

Model Code

Technical specifications

Operating Parameters

System design Parameters

Features

Controls

Options



Bearing life and external shaft loading

Bearing life:

Bearing life is a function of speed, pressure, swashplate angle and external loads. Oil type and viscosity impact bearing life.

	PM20-28
Bearing life (B ₁₀ hours)	19 965

Normal bearing life in B₁₀ hours is shown in the table above. Figures have been calculated under the following operating conditions : A continuous differential pressure of 120 bar [1740 PSI], 1800 rpm shaft speed, 22 bar [290 PSI] charge pressure, maximum displacement, without any external shaft side load. The data is based on a 50% forward, 50% reverse duty cycle, and standard charge pump size.

Shaft Loads

PM20 pumps are designed with bearings that can accept external radial and thrust loads. The external radial shaft load limits depend on the load position, orientation, and operating conditions of the unit.

The maximum permissible radial load (Re), is based on the maximum external moment (Me), and the distance (L) from the mounting flange to the load. It may be determined using the table and formula below. Thrust (axial) load limits are also shown.

$$Re = Me / L$$

All external shaft loads affect bearing life. In applications with external shaft loads, minimize the impact by positioning the load at 90° or 270° as shown in the figure.

Contact your Poclain Hydraulics representative for an evaluation of unit bearing life if:

- Continuously applied external loads exceed 25 % of the maximum allowable radial load Re.
- The pump swashplate is positioned on one side of center all or most of the time.
- The unit bearing life (B₁₀) is critical.

	External moment (Me) N.m [in.lbf]	Maximum shaft thrust in (T _{in}) N [lbf]
PM20-28	44 [389]	1 000 [224.8]

at 120 bar [1 740 PSI] and 3 600 rpm

Radial and thrust load position

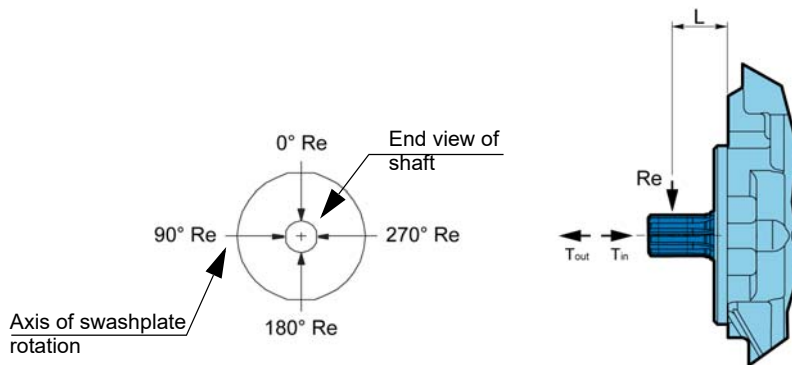

For an accurate calculation, consult your Poclain Hydraulics application engineer and use new AXEL program.



Hydraulic unit life

Hydraulic unit life is the life expectancy of the hydraulic components. It depends on speed and system pressure even if , system pressure is the dominant operating variable. High pressure, generated by high load, reduces hydraulic unit life.

Design the hydraulic system according to the expected machine duty cycle. Take in consideration the expected percentages of time at various loads and speeds. Ask your Poclain Hydraulics representative to calculate an appropriate pressure based your hydraulic system design. If duty cycle data is not available, input power and pump displacement are used to calculate system pressure.

All pressure limits are differential pressures (referenced to charge pressure) , taking a normal charge pressure in consideration.

PM20 pumps will meet satisfactory life expectancy if applied within the parameters specified in this technical documentation. For more detailed information on hydraulic unit life see Operating Parameters in page 9.

Mounting flange loads

Adding tandem mounted pumps, and/or tandem auxiliary pump(s), subjecting pumps to shock loads may generate excessive loads on the front mounting flange. The overhung load moment for multiple pump mounting can be estimated as shown in the figure below.

Overhung load example

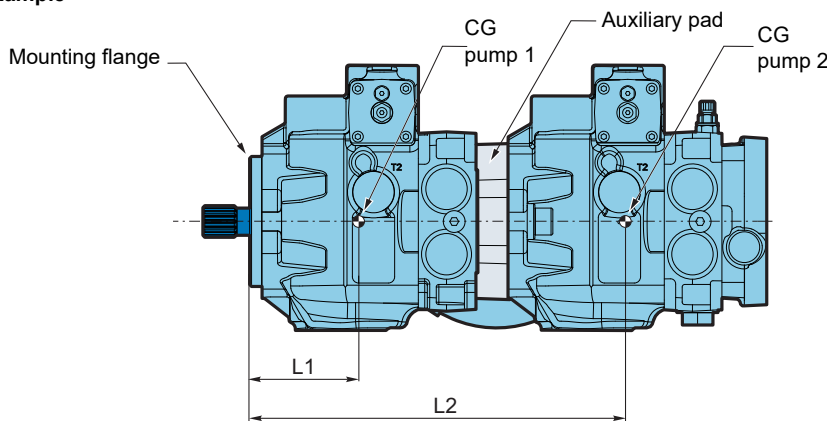

Estimating overhung load moments

W = Weight of pump (kg)
 L = Distance from mounting flange to pump center of gravity (CG)
 $M_R = G_R (W_1L_1 + W_2L_2 + \dots + W_nL_n)$
 $M_S = G_S (W_1L_1 + W_2L_2 + \dots + W_nL_n)$

Where:
 M_R = Rated load moment (N.m)
 M_S = Shock load moment (N.m)
 G_R^* = Rated (vibratory) acceleration (G's) (m/sec²)
 G_S^* = Maximum shock acceleration (G's) (m/sec²)

* Calculations will be carried out by multiplying the gravity (g = 9.81 m/sec²) with a given factor. This factor depends on the application. Allowable overhung load moment are shown in the below table. Exceeding these values requires additional pump support.

	Rated moment (MR)	Shock load moment (MS)
	N.m [in.lbf]	N.m [in.lbf]
PM20-20	370 [3 274]	600 [5 310]
PM20-25	370 [3 274]	600 [5 310]
PM20-28	370 [3 274]	600 [5 310]



For an accurate calculation, consult your Poclain Hydraulics application engineer.

Model Code

Technical specifications

Operating Parameters

System design Parameters

Features

Controls

Options



FEATURES

High pressure relief valve

The High pressure relief valves maintain circuit pressure in the proper range. The check valves allow charge flow to replenish the low pressure loop of the circuit. The high pressure relief valves ensure a high pressure protection of the high pressure loop of the circuit.

High pressure relief valves are available in a wide range of settings.

When high pressure relief valves are not desired, pumps is equipped with charge circuit check valves only. The High pressure relief valve are not adjustable. To change setting is necessary to change the whole valve.



High pressure relief valves are intended for transient overpressure protection and are not intended for continuous pressure control. Flow over relief valves for extended periods of time may result in severe heat build up. High flows over relief valves may result in pressure levels exceeding the nominal valve setting and potential damage to system components.



High pressure relief valve	Available setting bar [PSI]	
Without	-	00
	150 [2 175]	15
	200 [2 900]	20
With	250 [3 625]	25
	300 [4 351]	30
	350 [5 076]	35
	370 [5 366]*	37

* Consult your Poclain Hydraulics application engineer.

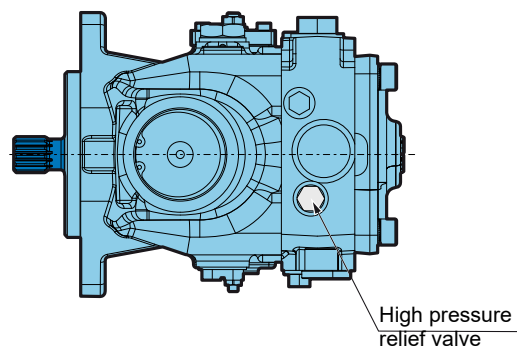
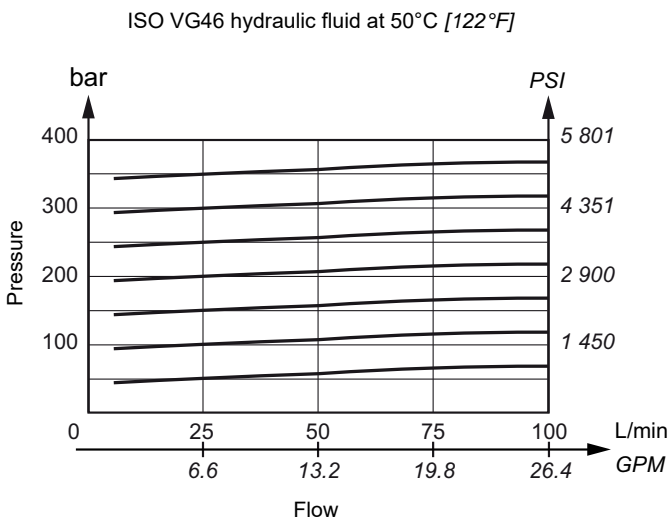
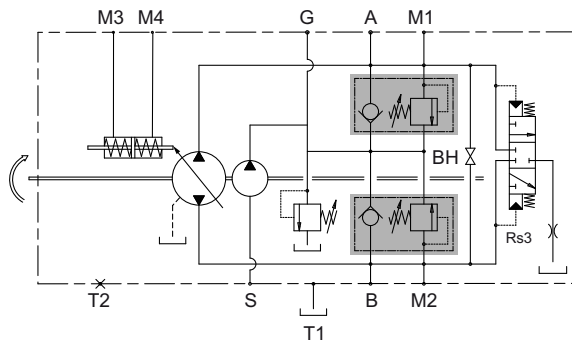

The high pressure relief valve setting is not the differential pressure between A and B ports



Model Code

Technical specifications

Operating Parameters

System design Parameters

Features

Controls

Options

Charge relief valve

The charge pressure relief valve provides a relief outlet for charge circuit. This valve is used to set the charge pressure of the circuit. Flow through the valve is ported to case.

The nominal charge relief setting is referenced to case pressure.



Incorrect charge pressure settings may result in the inability to build required system pressure and/or inadequate loop flushing flows. Ensure correct charge pressure under all conditions of operation to maintain pump control performance.



Charge relief valve	Available setting bar [PSI]	
Without	-	00
With	22 [319]	22

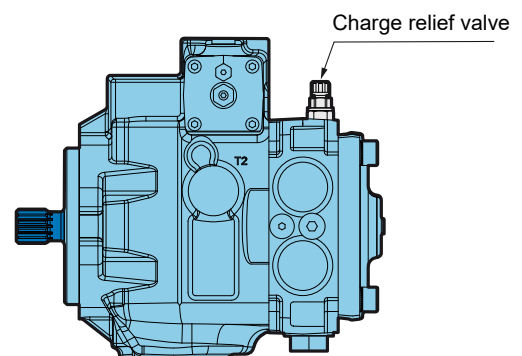
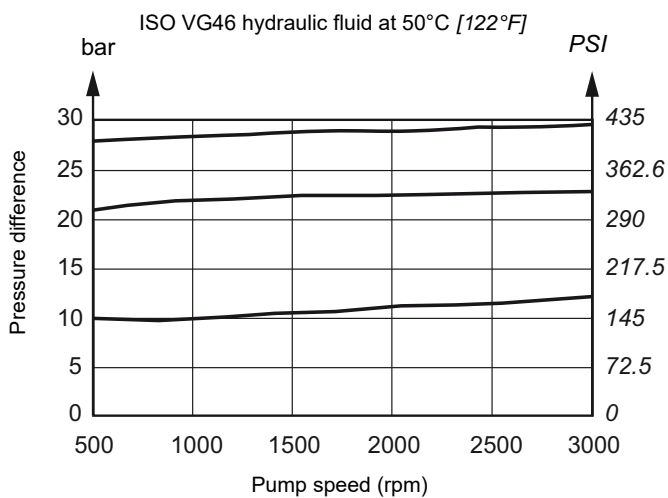
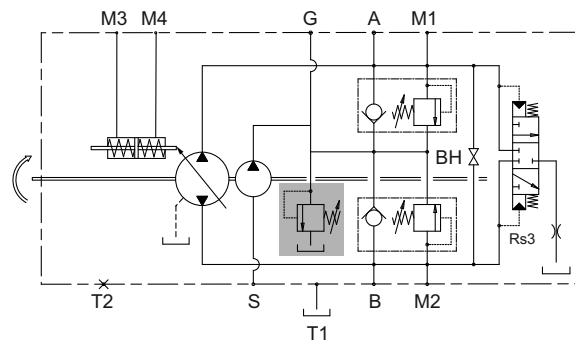



Charge pump

Charge flow is required on all PM20 pumps used in closed circuit installations. The charge pump provides flow to make up internal leakage, maintain a positive pressure in the main circuit, provide flow for cooling and filtration, replace any leakage losses from external valving or auxiliary systems, and to provide flow and pressure for the control system.

Many factors influence the charge flow requirements. These factors include system pressure, pump speed, pump swashplate angle, type of fluid, temperature, size of heat exchanger, length and size of hydraulic lines, control response characteristics, auxiliary flow requirements, hydrostatic motor type, etc.

Unusual application conditions may require a more detailed review of charge pump sizing. Charge pressure must be maintained at a specified level under all operating conditions to prevent damage to the transmission. Poclain Hydraulics recommends testing under actual operating conditions to verify this.

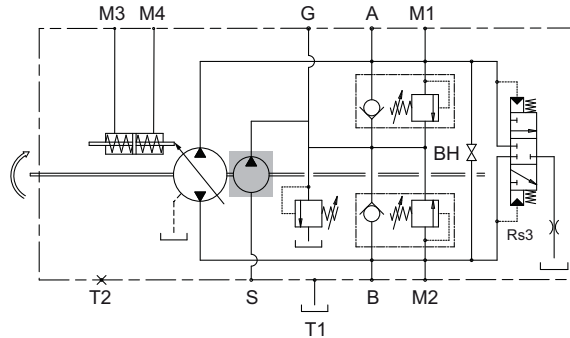

Charge pump sizing/selection

In most applications, a general guideline is that the charge pump displacement should be at least 20% of the main pump displacement.



Charge pump	Displacement cm ³ /rev [in ³ /rev]	
Without	-	00
	9 [0.55]	08
With	11 [0.67] *	11
	12 [0.73]	12

* Only and mandatory for PM20 hydraulic automotive control.

Pump without internal charge pump is also available. In this case an external flow must provide charge pressure and charge flow in order to assure the requested pump performance.



Contact your Poclain Hydraulics application engineer for more information.



Pump version without internal charge pump is available. In this case an external flow must provide charge pressure and charge flow in order to assure the requested pump performance.



Displacement limiters

PM20 are designed with mechanical displacement (stroke) limiters. You can limit maximum displacement of the pump to a certain percent of its maximum displacement to near zero in both direction.

The displacement limiters are located on the both sides of the servo piston and are adjustable by screw.



Take care in adjusting displacement limiters to avoid an undesirable condition of output flow or speed. Retorque the sealing lock nut after every adjustment to prevent an unexpected change in output conditions and to prevent external leakage during pump operation.

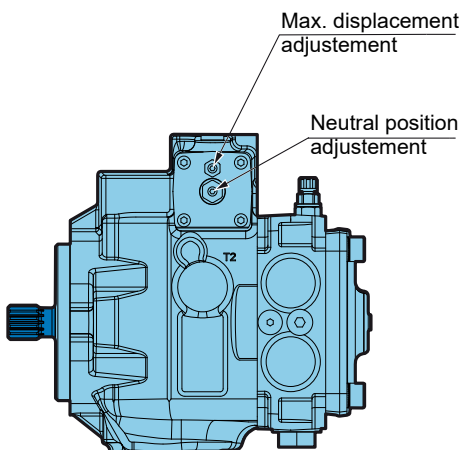

By-pass

PM20 features a by-pass function. By-passing Port A and Port B is achieved by unscrewing a screw located on the cover. The by-pass connect the ports A-B and must be use only in emergency case and only for short movement.

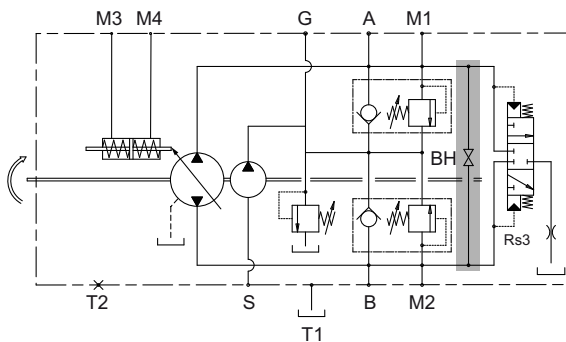
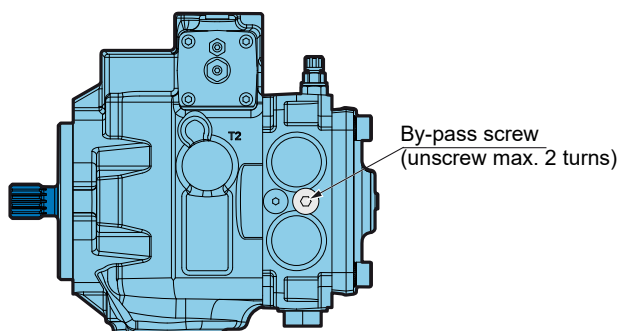

To avoid leakage, do not exceed two turns of the screw.



By-pass valve is intended for moving a machine for very short distances at very slow speeds. It is not intended as tow valve.



Mounting flange and shafts

SAE B- Splined shaft



S3 13 teeth; Max torque: 220 N.m [1 947 in.lbf]

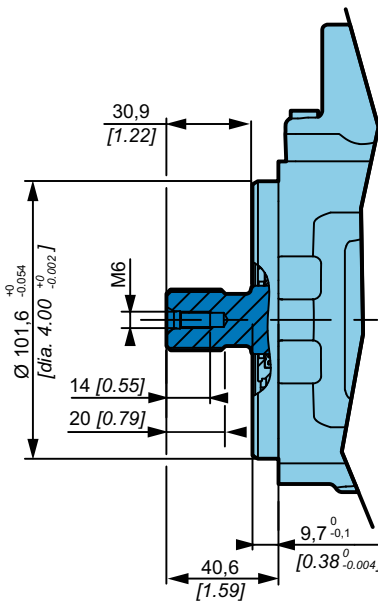

Splined ANSI B92.1a-1996
Pitch 16/32" DP
Pressure angle 30°
Tolerance class: 5

S4 15 teeth; Max torque: 360 N.m [3 186 in.lbf]

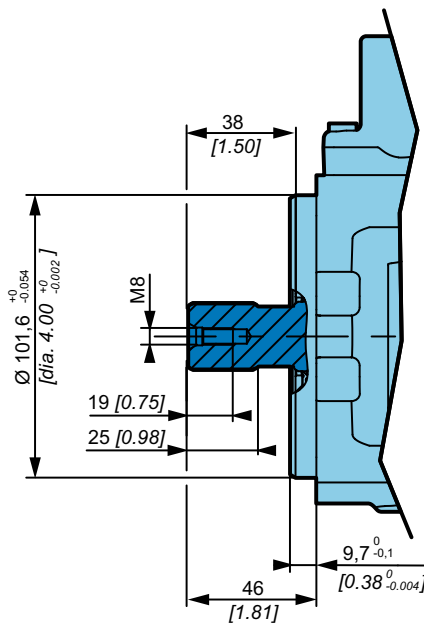

Splined ANSI B92.1a-1996
Pitch 16/32" DP
Pressure angle 30°
Tolerance class: 5

T Shaft for secondary tandem pump



Auxiliary mounting pad

SAE A flange

Max. Torque: 80 N.m [708 in.lbf]



00 Without charge pump

09 With charge pump: 9,0 cm³/rev [0.54 in³/rev]

11 With charge pump: 11,0 cm³/rev [0.67 in³/rev] *

12 With charge pump: 12,0 cm³/rev [0.73 in³/rev]

* Only and mandatory for PM20 hydraulic automotive control.

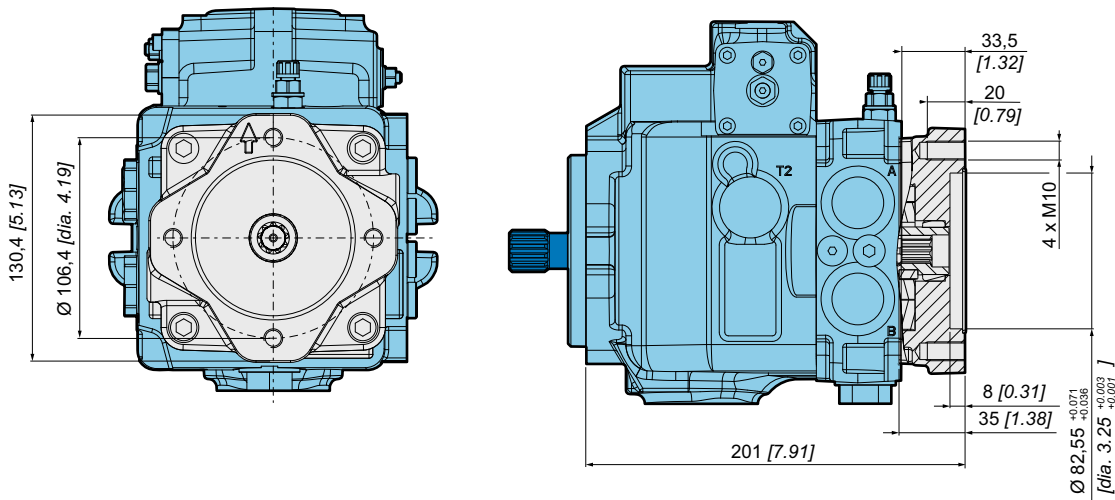

Splined ANSI B92.1a-1996
Pitch 16/32° DP
Pressure angle 30°
9 teeth
Tolerance class: 5



Do not rotate the auxiliary mounting pad cover.

Model Code

Technical specifications

Operating Parameters

System design Parameters

Features

Controls

Options



Tandem pumps

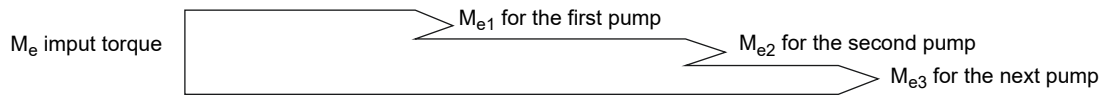
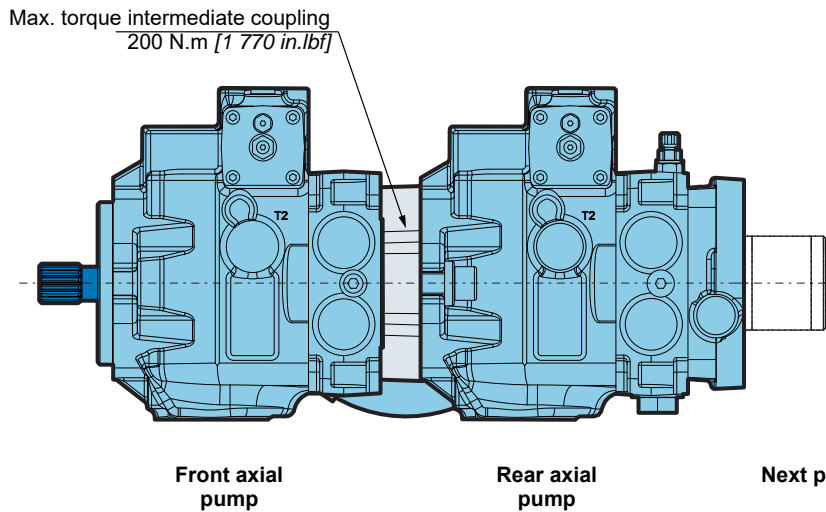

Torque required by auxiliary pumps is additive. Ensure requirements don't exceed shaft torque ratings.

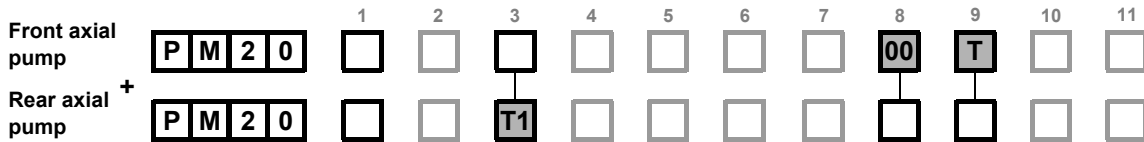

Number of charge pump in the tandem	Axial pump	Mounting flange and shaft	Charge pump	Auxiliary mounting flange		
				Charge pump	Auxiliary mounting flange	
0 charge pump	Front	SAE B; 13 teeth	Without	00	Tandem fitting	T
		SAE B; 15 teeth			S3	Without auxiliary mounting pad
	Rear	Shaft for secondary tandem pump	Without	00	SAE A flange	
1 charge pump *	Front	SAE B; 13 teeth	Without	00	Tandem fitting	T
		SAE B; 15 teeth			S3	Without auxiliary mounting pad
	Rear	Shaft for secondary tandem pump	With	08 or 12	SAE A flange	



* The charge pump can only be located on the rear axial pump.



Ports T and G of the first pump must be connected with ports T and G of the second pump.



* Auxiliary mounting flange S with charge pump is done closing SAE A by a steel cover. When SAE B will be available a tandem pump could be composed by 2 single = PM10.



Tandem pumps are not available for hydraulic automotive control.



Gear pumps

1 2 3 4 5 6 7 8 9 10 11

P M 2 0

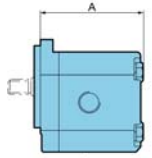
		Displacement		Pressure			Dimension			Mass	Efficiency
		cm ³ /rev [cu.in/rev]	Continuous max. pressure bar [PSI]	Max. intermittent pressure bar [PSI]	Max. peak pressure bar [PSI]	A mm [in]	B mm [in]	C mm [in]	kg [lb]	%	
A	SAE A										
		04	4 [0.24]	250 [3 625]	270 [3 915]	290 [4 205]	93,0 [3.66]				
		06	6,0 [0.37]	250 [3 625]	270 [3 915]	290 [4 205]	96,3 [3.68]				
		08	8,5 [0.52]	250 [3 625]	270 [3 915]	290 [4 205]	100,5 [3.96]				
		11	11,0 [0.67]	250 [3 625]	270 [3 915]	290 [4 205]	104,6 [4.12]	106,4 [4.19]	82,5 [3.25]		95 *
		14	14 [0.85]	250 [3 625]	270 [3 915]	290 [4 205]	109,6 [4.21]				
		17	16,5 [1.01]	230 [3 335]	240 [3 480]	250 [3 625]	113,8 [4.37]				
		20	19,5 [1.19]	210 [3 045]	220 [3 190]	230 [3 335]	118,8 [4.68]				

Gear pumps are always delivered flanged on the axial pump. They can not be sold alone.

* Value collected during the testing at 1500 rpm.

Model Code

Technical specifications

Operating Parameters

System design Parameters

Features

Controls

Options



CONTROLS

Mechanical servo control with feedback



Control function	The variation in pump displacement is reached by control lever rotation to adjust hydraulic servo piston position. Control lever range is 34°. Movement of control lever is independent of the pressure and pump speed.
Control regulation	To avoid sudden accelerations and stoppages, two restrictors (Rs1 and Rs2) are inserted between servo control and hydraulic servo piston.
Feedback function	The feedback system between swash plate and hydraulic servo piston permit to maintain constant displacement of the pump if the pressure between pump and hydraulic motor changes. The feedback function is reached by a lever that connects the swashplate and the hydraulic servo piston.

Flow rate determination

Rotation	Pressure	Output	Input
Clockwise (R)	Y	A	B
	X	B	A
Counter clockwise (L)	Y	B	A
	X	A	B

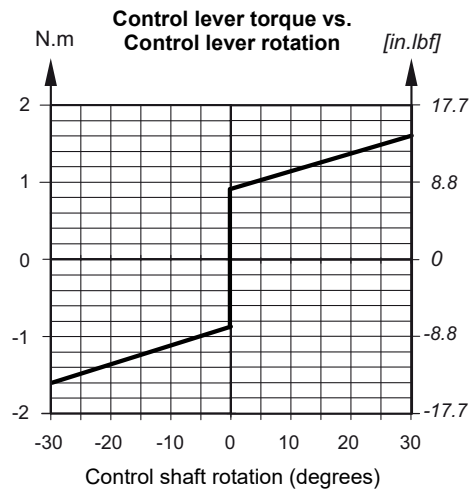
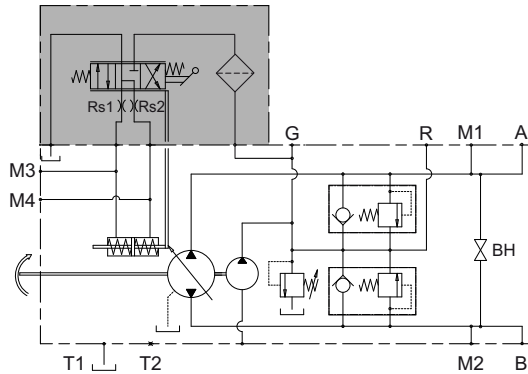
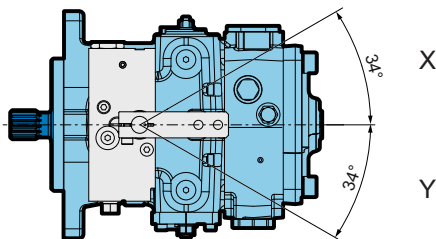

The spring return feature in the control unit is not a safety device.



To prevent damage to the control A a positive mechanical stop must be provided for the control A linkage.



Dimensions with control A

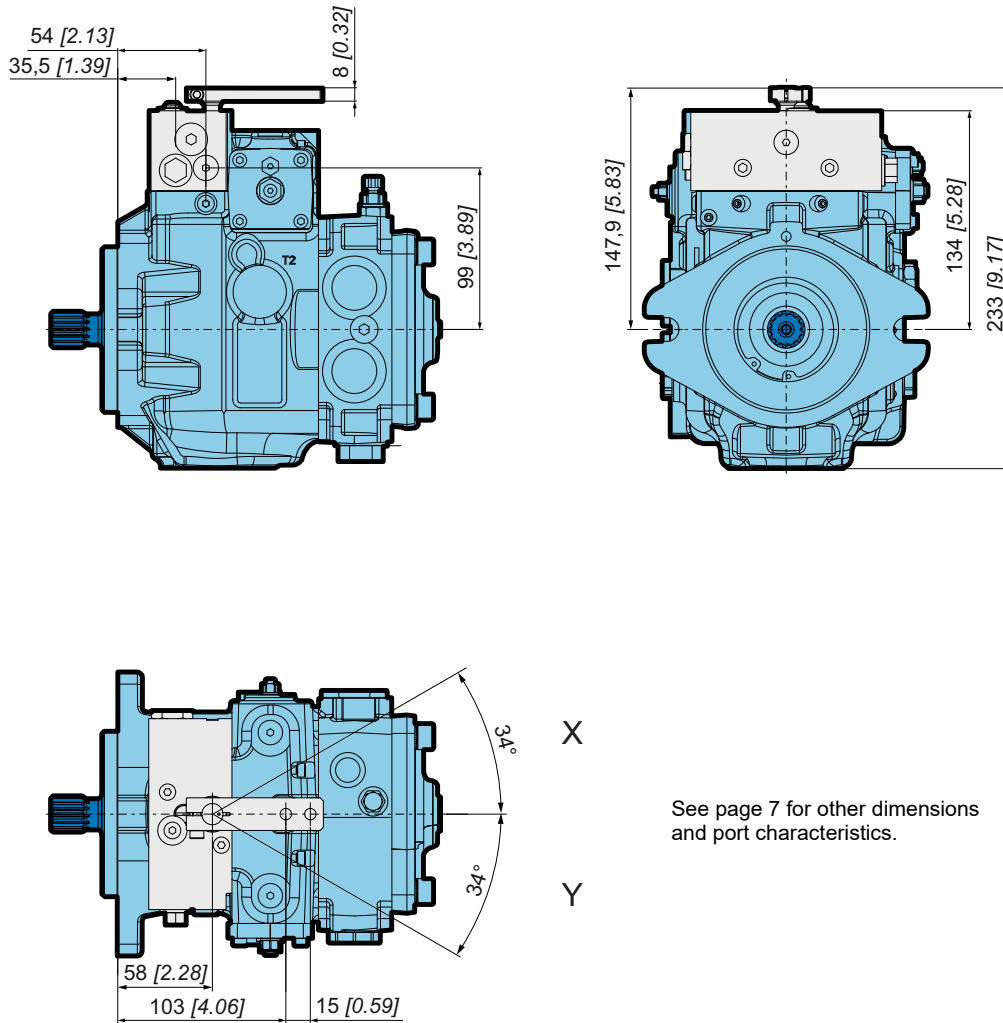

See page 7 for other dimensions and port characteristics.

Model Code

Technical specifications

Operating Parameters

System design Parameters

Features

Controls

Options



Hydraulic servo control



Control function	The variation in pump displacement is reached by pressure adjustment on the M3 and M4 servo control ports. These ports are controlled by hydraulic proportional joystick (containing pressure reduction valves). The joystick supply can be obtained by taking pressure from the auxiliary pump (R connection). Basic joystick can be provided upon request.
Control regulation	The servo control response time can be adjusted by two restrictors (Rs1 and Rs2) inserted on the joystick supply line.

Flow rate determination

Rotation	Pressure	Output	Input
Clockwise (R)	M3	B	A
	M4	A	B
Counter clockwise (L)	M3	A	B
	M4	B	A

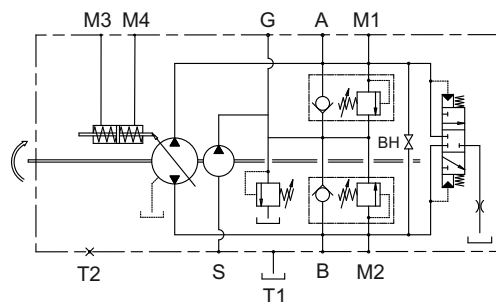

Servo pressure vs. Displacement

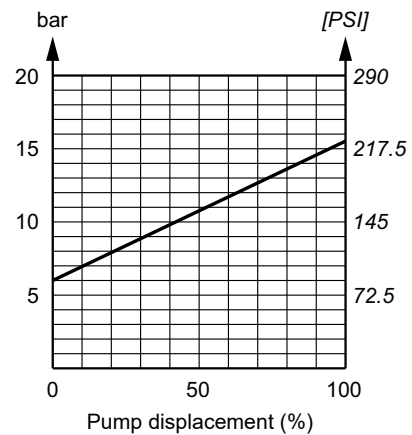

Other curves can be used in relation to valve plate timing. Contact your Poclairn Hydraulics application engineer for further info.



For the selection of the regulation curve (with or without step) of the Joystick contact your Poclairn Hydraulics application engineer.



The back pressure of the return line of the joystick and the drive line of the pump have an influence on Servo pressure vs Displacement values.



The spring return feature in control is not a safety device.



Above graph is just an example that shows the relationship between Servo pressure and Displacement.



Dimensions with control S

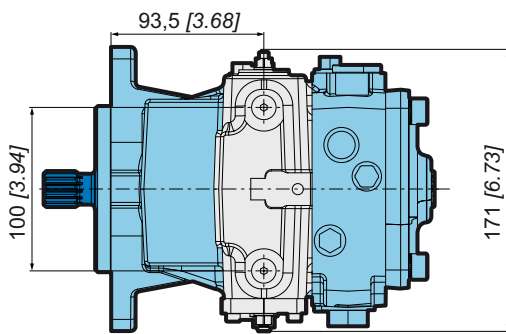
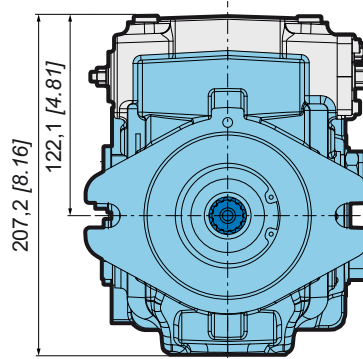
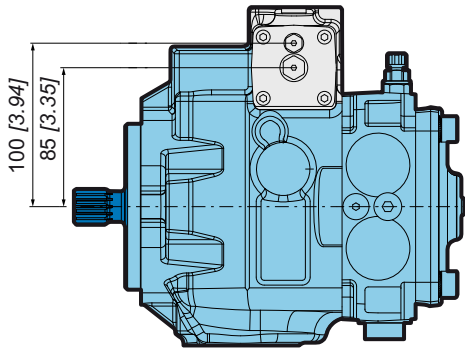

See page 7 for other dimensions and port characteristics.

Model Code

Technical specifications

Operating Parameters

System design Parameters

Features

Controls

Options



Hydraulic automotive control



Control function	The variation in pump displacement is reached by continuous electro-hydraulic valve adjustment. The adjustment is precised by pilot pressure controlled by solenoid control. The pilot pressure increases proportionally to the rotation of the pump. The pump displacement increases corresponding to the higher pilot pressure.
Control regulation	In case the engine is overloaded, the rotation rate decreases and the pilot pressure is reduced causing a pump displacement reduction with a corresponding drop in absorbed power.
Inching function	Inching function is reached by reduction of the pilot pressure, independently of the pump rotation speed. Consequently the pump displacement is reduced.

Supply voltage	12V	D12
	24V	D24

Flow rate determination

Rotation	Pressure	Output	Input
Clockwise (R)	EV1	B	A
	EV2	A	B
Counter clockwise (L)	EV1	A	B
	EV2	B	A

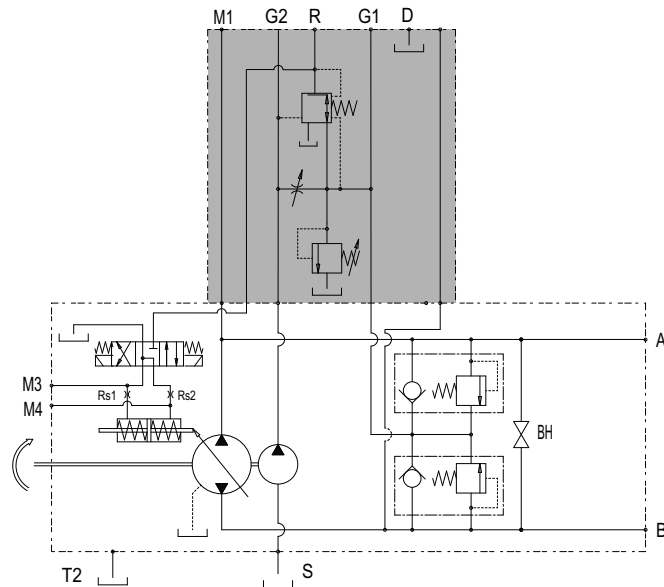

It is mandatory to use 11 cc/rev charge pump, for any clarification or details contact your Poclain Hydraulics application engineer.



Dimensions with control D

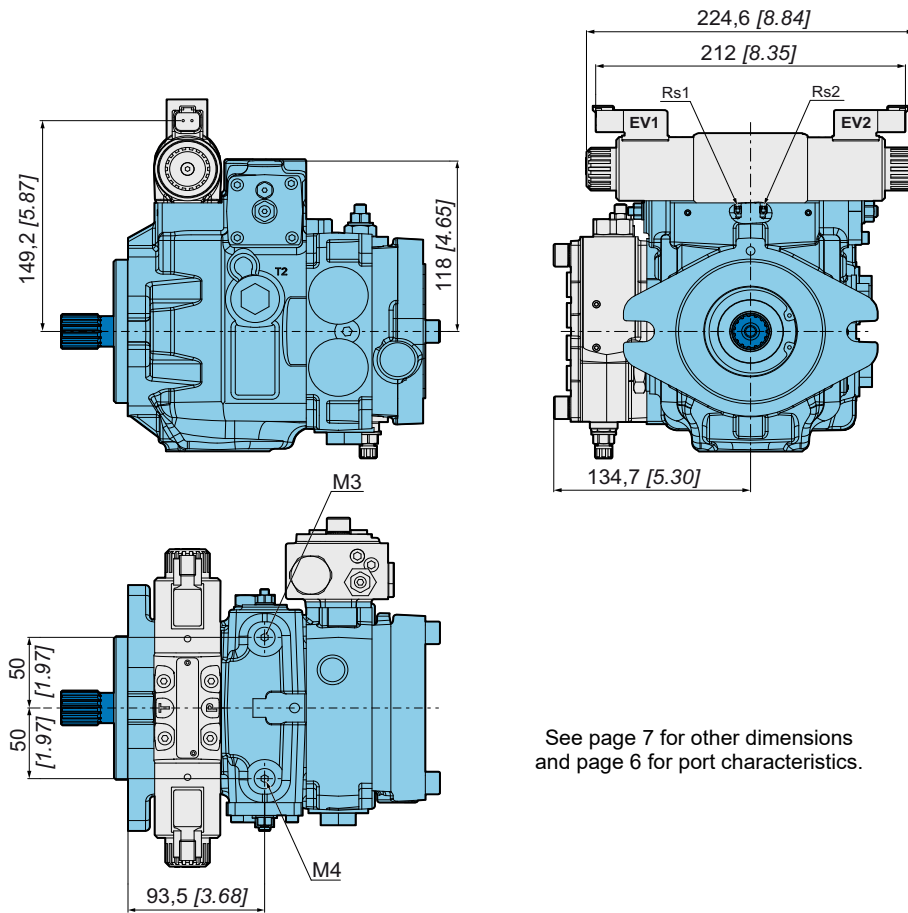

See page 7 for other dimensions and page 6 for port characteristics.

Solenoids specification		
Operating voltage	12 VDC	24 VDC
Current	1500 mA	750 mA
Resistance at 20°C [68°F]	5,3 Ω ± 5%	21,2 Ω ± 5%
Connector type	Deutsch DT04-2P / AMP Junior timer / EN 175301	
Protection	IP69K / IP67 / IP67	

Model Code

Technical specifications

Operating Parameters

System design Parameters

Features

Controls

Options



Electro-proportional servo control



Control function	The variation in pump displacement is reached by current adjustment applied to proportional valve coils. The coils then adjust the pressure of the servo control connected to the hydraulic servo piston. The flow rate direction depends on activated coil.
Control regulation	The reaction time can be controlled by ramps installed on the card and by restrictors (Rs1 and Rs2) positioned between the electrovalves and the hydraulic servo piston.

Supply voltage	
12V	P12
24V	P24

Flow rate determination

Rotation	Control	Output	Input
Clockwise (R)	EP1	B	A
	EP2	A	B
Counter clockwise (L)	EP1	A	B
	EP2	B	A



Valve plate timing and regulation curve of proportional valve influence the flow. Contact your Poclairn Hydraulics application engineer for further info.

Solenoids specification

Operating voltage	12 VDC	24 VDC
Current	1500 mA	750 mA
Resistance at 20°C [68°F]	5,3 Ω ± 5%	21,2 Ω ± 5%
Connector type	AMP Junior / Deutsch DT04-2P	
Protection	IP6K6 / IPX9K	



The current must not exceed 1500 mA under 12V and 800 mA under 24V.

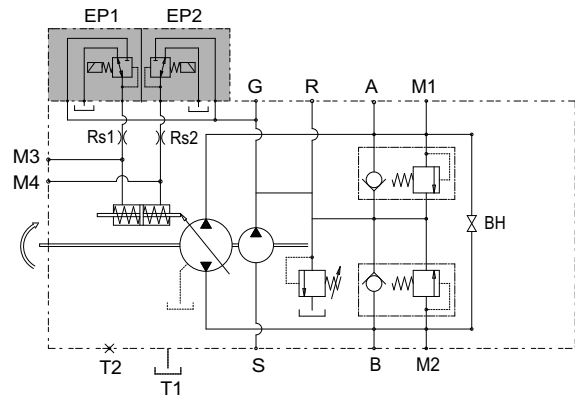

Electrovalve current vs Displacement

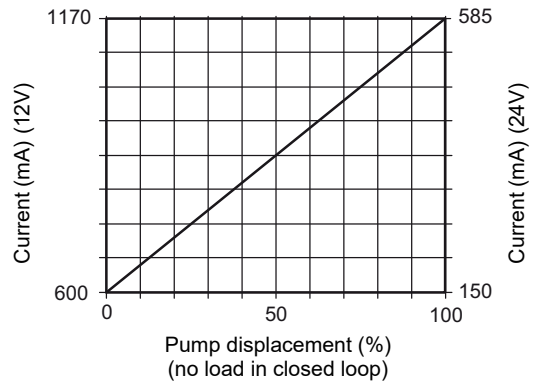



Dimensions with control P

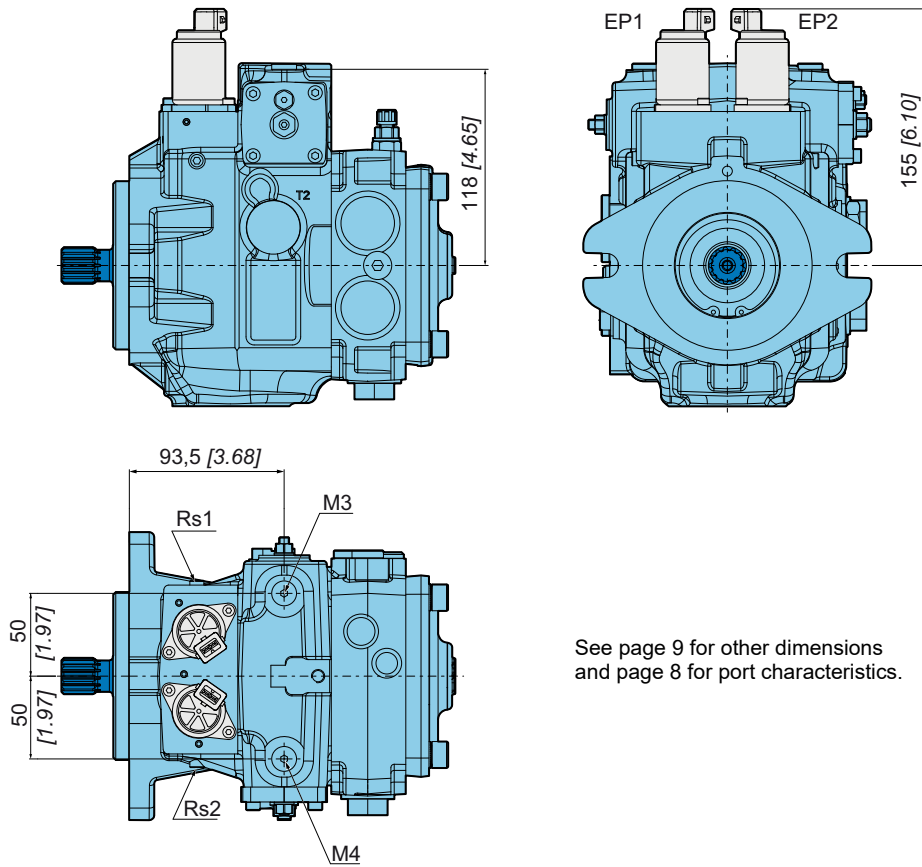

See page 9 for other dimensions and page 8 for port characteristics.

Model Code

Technical specifications

Operating Parameters

System design Parameters

Features

Controls

Options



Electro-proportional control with feedback



Control function	The variation in pump displacement is reached by current adjustment applied to electro-proportional coils. The coils then adjust the pressure of the servo control. The flow rate direction depends on activated coil.
Control regulation	The reaction time can be controlled by ramps installed on the card and by restrictors (Rs1 and Rs2) inserted between the servo control and the hydraulic servo piston.
Feedback function	The feedback function is reached by a lever that connects the swashplate and the hydraulic servo piston. To avoid sudden accelerations and stoppages, two restrictors (Rs1 and Rs2) are inserted between the servo control and the hydraulic servo piston.

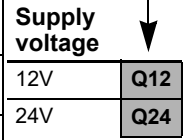

Flow rate determination

Rotation	Control	Output	Input
Clockwise (R)	EP1	B	A
	EP2	A	B
Counter clockwise (L)	EP1	A	B
	EP2	B	A

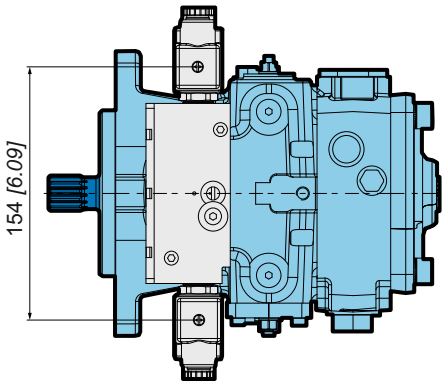
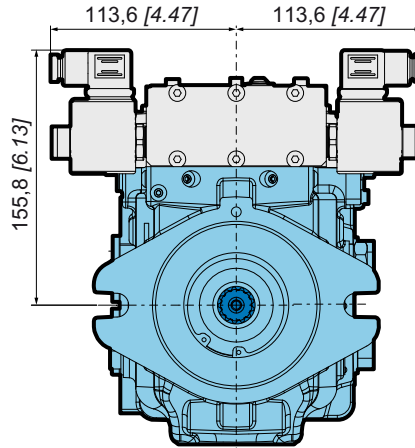
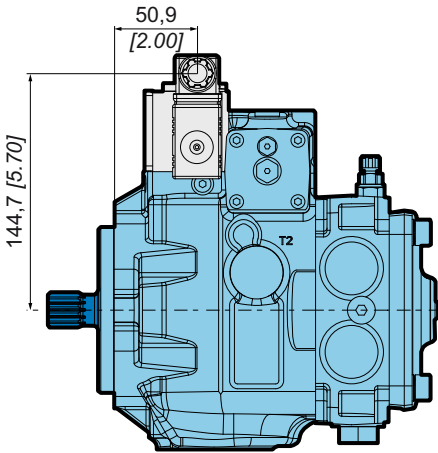
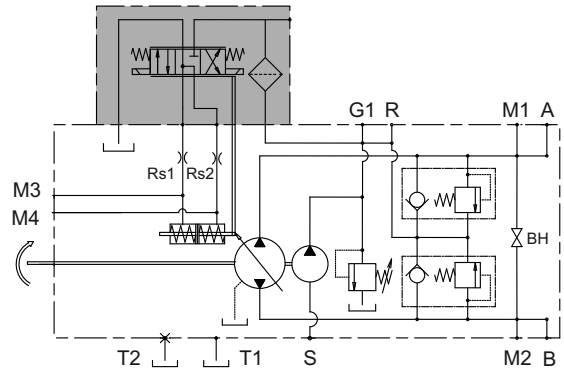

Electrovalve current vs Displacement

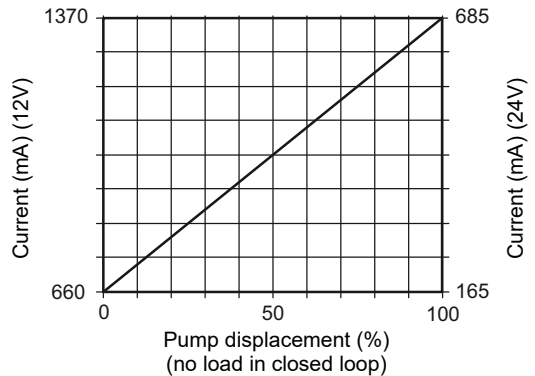

Type of connector: Standard DIN 43650 on request Deutsch



OPTIONS

Roller bearing

P	M	2	0	1	2	3	4	5	6	7	8	9	10	11
				<input type="checkbox"/>	<input type="checkbox"/>	<input type="checkbox"/>	<input type="checkbox"/>	<input type="checkbox"/>	<input type="checkbox"/>	<input type="checkbox"/>	<input type="checkbox"/>	<input type="checkbox"/>	<input type="checkbox"/>	<input checked="" type="checkbox"/> CR

The PM20 can be provided with high capacity roller bearing to extend lifetime of the application. According to characteristics of shaft load, the duty cycle and lifetime expectancy a roller bearing might be needed.



Consult your Poclain Hydraulics application engineer for the application of this option.

Customized identification plate

P	M	2	0	1	2	3	4	5	6	7	8	9	10	11
				<input type="checkbox"/>	<input type="checkbox"/>	<input type="checkbox"/>	<input type="checkbox"/>	<input type="checkbox"/>	<input type="checkbox"/>	<input type="checkbox"/>	<input type="checkbox"/>	<input type="checkbox"/>	<input type="checkbox"/>	<input checked="" type="checkbox"/> DP

It is possible to provide our products with dedicated plate (your part number engraved on the plate) when requested.



This option is available only for minimum volume of 50 pieces.



Consult your Poclain Hydraulics application engineer for other possibilities.

Mechanical inching

P	M	2	0	1	2	3	4	5	6	7	8	9	10	11
				<input type="checkbox"/>	<input type="checkbox"/>	<input checked="" type="checkbox"/> D12 <input checked="" type="checkbox"/> D24	<input type="checkbox"/>	<input type="checkbox"/>	<input type="checkbox"/>	<input type="checkbox"/>	<input type="checkbox"/>	<input type="checkbox"/>	<input type="checkbox"/>	<input checked="" type="checkbox"/> IC

The PM20 with Hydraulic automotive control D (page 28) can be provided with an Inching lever to reduce the pilot pressure independently of the pump rotation speed.

Finishing coat

P	M	2	0	1	2	3	4	5	6	7	8	9	10	11
				<input type="checkbox"/>	<input type="checkbox"/>	<input type="checkbox"/>	<input type="checkbox"/>	<input type="checkbox"/>	<input type="checkbox"/>	<input type="checkbox"/>	<input type="checkbox"/>	<input type="checkbox"/>	<input type="checkbox"/>	<input checked="" type="checkbox"/> PA

The pumps can be delivered with finishing coat when requested. Standard paint is RAL 9005 (black color).



Consult your Poclain Hydraulics application engineer for other colors of topcoat.

Fluorinated elastomer seals

P	M	2	0	1	2	3	4	5	6	7	8	9	10	11
				<input type="checkbox"/>	<input type="checkbox"/>	<input type="checkbox"/>	<input type="checkbox"/>	<input type="checkbox"/>	<input type="checkbox"/>	<input type="checkbox"/>	<input type="checkbox"/>	<input type="checkbox"/>	<input type="checkbox"/>	<input checked="" type="checkbox"/> EV

Standard NBR sealing are designed to resist to temperature up to 90°C [194°F] and to HV type oils. According to characteristics of application, fluorinated elastomer seals might be needed.



Consult your Poclain Hydraulics application engineer for the application of this option.

Model Code

Technical specifications

Operating Parameters

System design Parameters

Features

Controls

Options



Filter on pressure line

The PM20 pump can be provided with a F0/F2 filter. It's placement on pressure line ensures that only filtered oil enters the pump closed loop. Maximum pressure difference between filter cartridge input and output is 2 bar [29 PSI]. After reaching 2 bar [29 PSI], the cartridge has to be changed.

Tightening torque: 35 Nm [309 in.lbf], Max. working pressure: 30 bar [435 PSI], Filter fitness: 10 micron

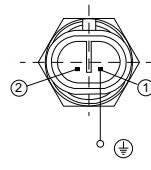
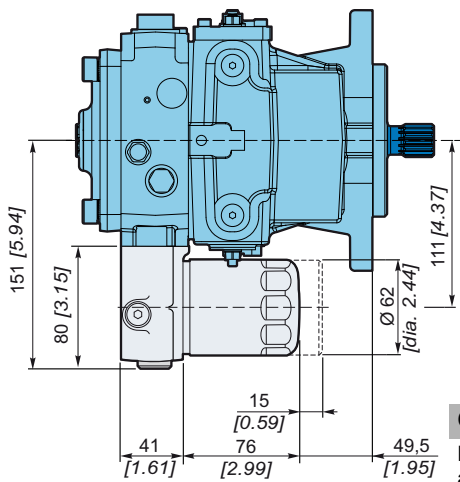
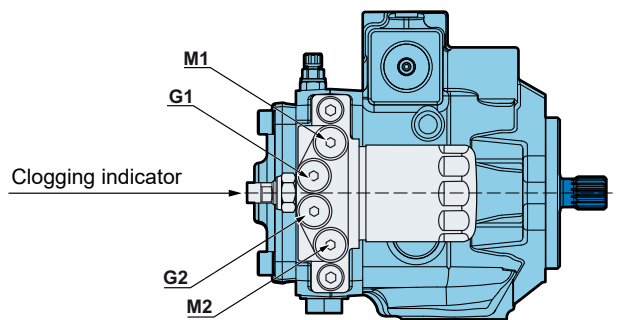
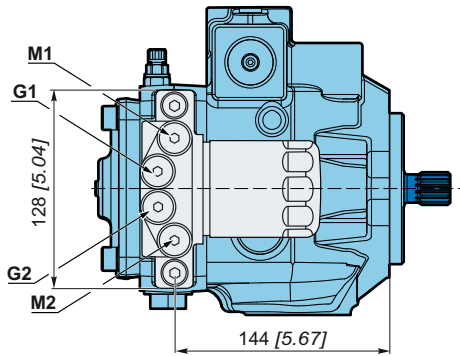
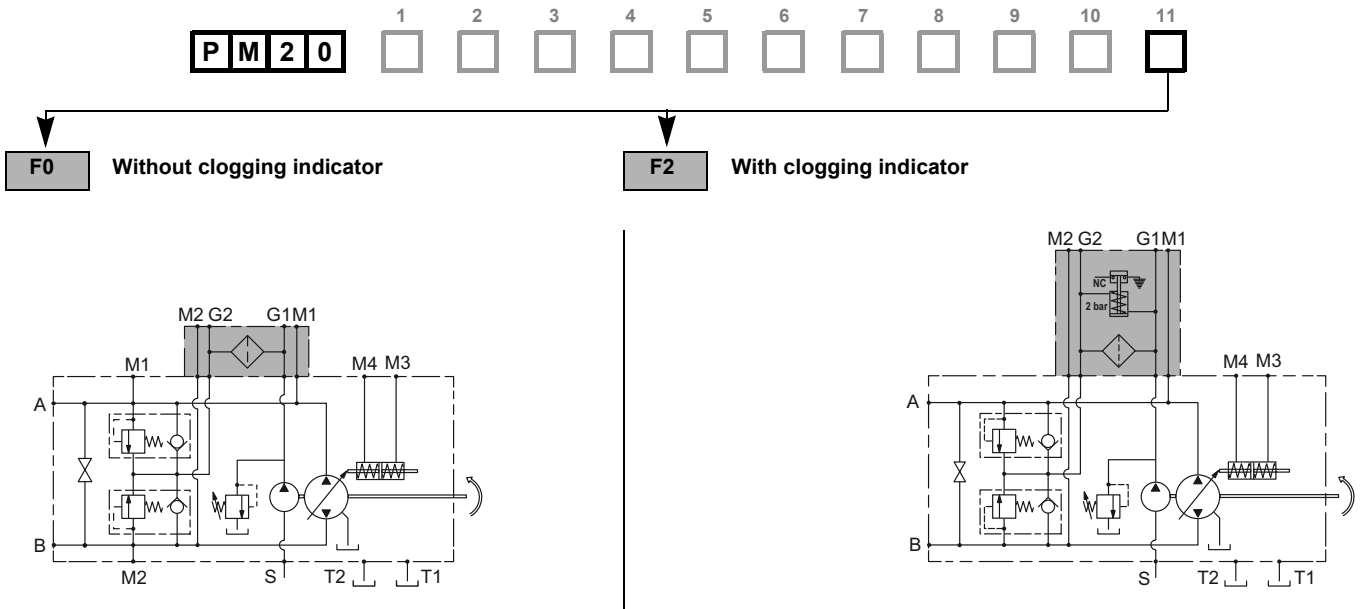

Normally closed contact.
Thread of clogging indicator is internally connected to the ground.

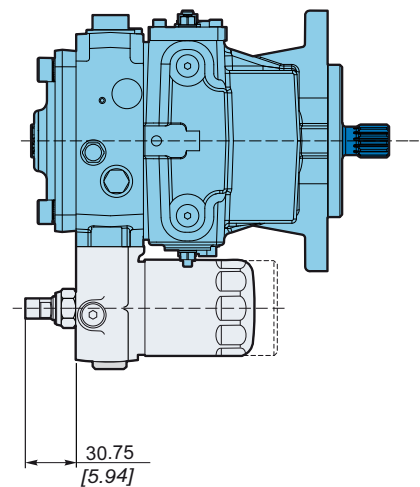

Clogging indicator specification

Differential working adjustment	3 ± 0,2 bar [44 ± 3 PSI]
Working temperature	-30°C ~ 110 °C [-22°F ~ 230°F]
Max. vibration level	50 g
Connector type	AMP super seal, 2 way
Current range	0,1-0,2 A max.



External connections for filter

1 2 3 4 5 6 7 8 9 10 11 **F3**

UNF thread ports

1 2 3 4 5 6 7 8 9 10 11 **FU**

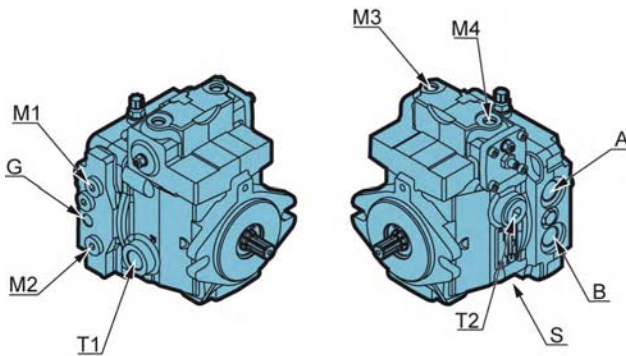

Port	Function	ISO 11926-1 (option FU)
A-B	Services	1-1/16-12 UNF-2B
G1	Auxiliary	9/16-18 UNF-2B
M1/M2	Gauge	7/16-20 UNF-2B
M3/M4	Servo control pilot	7/16-20 UNF-2B
S	Suction	1-1/16-12 UNF-2B
T1	Drain	1/2" GAS
T2	Drain	7/8-14 UNF 2B
G2	Auxiliary	3/8" GAS

Flushing valve

1 2 3 4 5 6 7 8 9 10 11 **VS**

The PM20 can be provided with a flushing valve to discharge the oil inside the pump casing. It is achieved through a relief valve of the flushing valve. The exchange valve is useful in case the temperature of the oil in the closed circuit is too high.

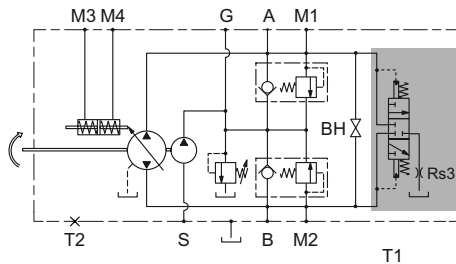

Consult your Poclain Hydraulics application engineer for the size of restrictor of flushing valve.

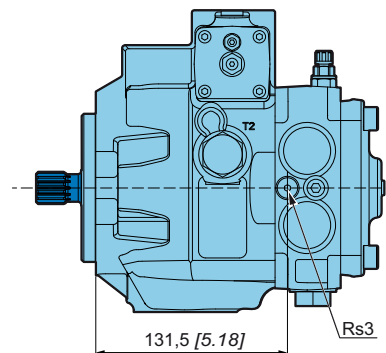
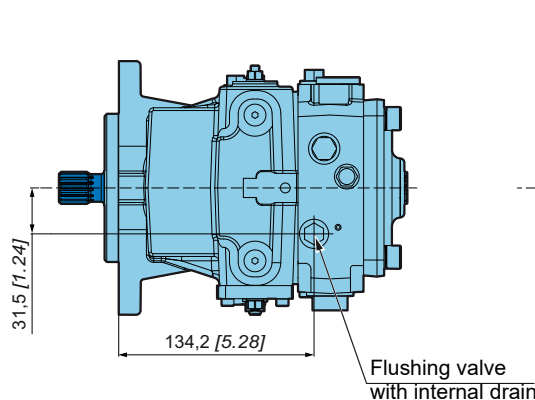

Model Code

Technical specifications

Operating Parameters

System design Parameters

Features

Controls

Options



Safety valve



The PM20 with Mechanical servo control A (page 24) can be provided with a safety valve VPU. Without current, the VPU disconnects the servo control from the charge pressure and engages negative brake.

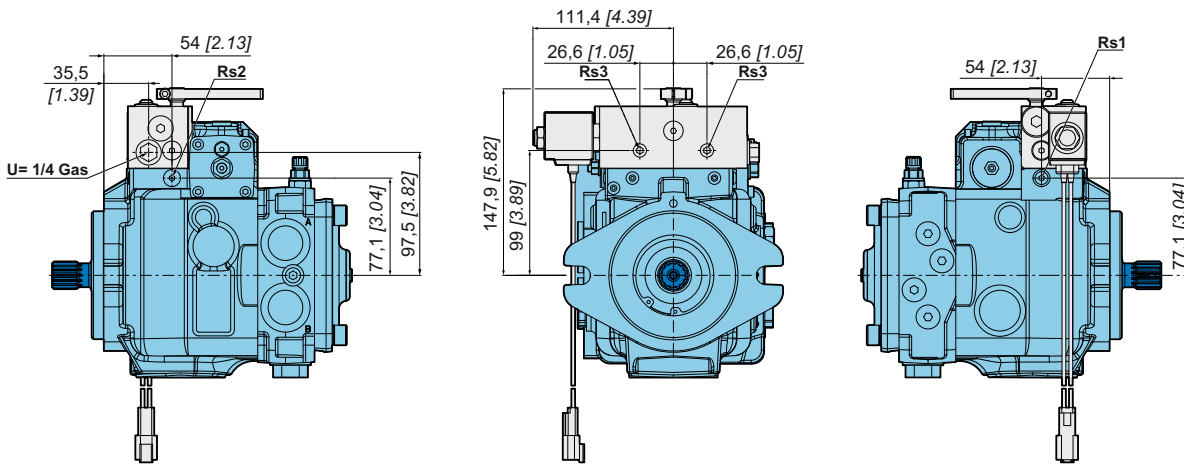
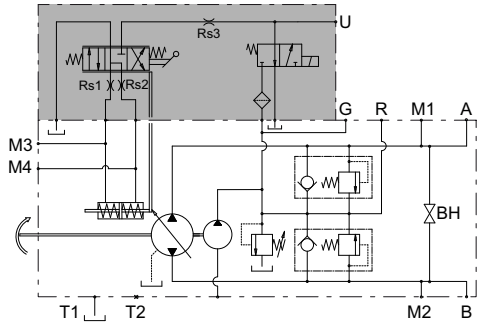

Coil specification

Type of connector	DIN 43650
Nominal voltage	12V DC
Power	18W
Type of protection	IP 65
Ambient temperature range	from -30°C to 60°C [-22°F to 140°F]
Magnet wire insulation	Class H -> 200°C [392°F]
Heat insulation	Class H -> 180°C [356°F]
Mass	0,19 kg [0.42 lb]
Lead wires	600V rating with strain relief

Connector specification

AC rated voltage	250V max.
DC rated voltage	300V max.
Pin contact rated flow	10A
Pin contact max. flow	16A
Max. cable section	1,5 mm ² [0.002 in ²]
Ø Cable gland PG09-M16x1,5	6 to 8 mm [0.24 to 0.31 in]
Type of protection	IP65 EN60529
Insulation class	VDE 0110-1/89
Operating temperature	from -40°C to 90°C [-40°F to 194°F]

Anti-stall valve



The PM20 can be provided with anti-stall valve SD. It consists a cartridge valve (same cartridge valve as automotive control) which provides a pressure signal for the servo piston of the pump related to the speed of engine. Its function is to reduce pressure for servo piston in case of engine overload and consequent rpm reduction. As a result the pump de-strokes with an anti-stall effect.



For application of this option please contact your Poclairn Hydraulics application engineer.



Neutral position switch



The PM20 with Mechanical servo control A (page 29) can be provided with a micro switch to avoid engine start in case the control lever is not centered (zero position).

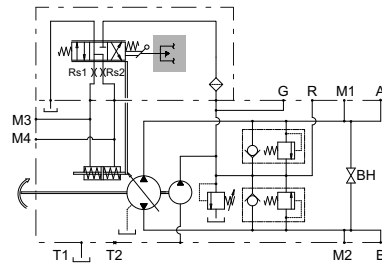
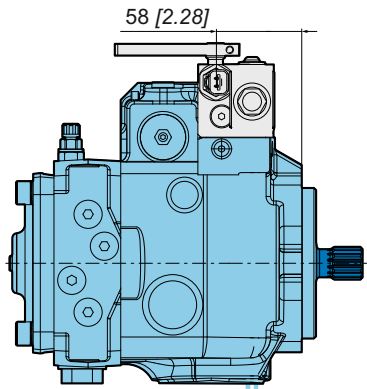

Electrical characteristics

Type of connector	Deutsch DT04-2P
Output	NC and NO
Cable connections	PG 13,2
Max. current	10 A
Electric load type	Resistive
Operating temperature	from -25°C to 80°C [-13°F to 176°F]
Type of protection	IP 67

Model Code

Technical specifications

Operating Parameters

System design Parameters

Features

Controls

Options





Model
Code

Technical
specifications

Operating
Parameters

System design
Parameters

Features

Controls

Options



Poclain Hydraulics reserves the right to make any modifications it deems necessary to the products described in this document without prior notification. The information contained in this document must be confirmed by Poclain Hydraulics before any order is submitted.

Illustrations are not binding.

The Poclain Hydraulics brand is the property of Poclain Hydraulics S.A.

 29/04/2024



B52513D

