

Axial piston pumps with variable displacement volume: LH30VO



The Liebherr LH30VO axial piston pumps were developed for open loop circuits in mobile and stationary applications.

The medium-pressure pumps have a swashplate design and a through-drive capacity of up to 130 %.

Further controls have been added, including power controls (LR), electrical volume flow controls (VE) with rising characteristic and additional jump function at signal loss (VK). They are tailored to the most common applications such as working hydraulics, ventilation, steering or power units.

Its increased performance and optimized production and assembly processes make the LH30VO an attractive, high-performance product for mobile and stationary applications that require a pressure range of up to 4,061 psi (280 bar).

valid for:

LH30VO 028
LH30VO 045
LH30VO 085

Features:

Series 20
Open loop circuit

Control types:

Pressure control
Volume flow control
Power control
Various combined controls

Pressure range:

Nominal pressure $p_{HD_N} = 4,061$ psi (280 bar)
Maximum pressure $p_{HD_{max}} = 4,641$ psi (320 bar)

Document identification:

ID number: 13452365
Date of issue: 09/2020
Authors: Liebherr - Department VH13
Version: 1.5

Table of contents

Axial piston pump
LH30VO 028 to 085

1	Type code	3
2	Technical data	7
2.1	Table of values	7
2.2	Maximum radial and axial force load on the driving shaft	8
2.3	Maximum input and through-drive torques	9
2.4	Direction of rotation	11
2.5	Permissible pressure range	11
2.6	Shaft sealing ring	14
2.7	Hydraulic fluids	14
3	Actuation and control type	17
3.1	Control types	17
3.2	Standard hydraulic diagrams	18
3.3	Control functions	27
3.4	Electrical components	36
4	Installation conditions	40
4.1	General information on project planning	40
4.2	Installation variants	41
4.3	Installation positions	43
5	Dimensions	44
5.1	NS 028, main dimensions	44
5.2	NS 028, mounting flange	47
5.3	NS 028, shaft end	48
5.4	NS 045, main dimensions	49
5.5	NS 045, mounting flange	52
5.6	NS 045, shaft end	53
5.7	NS 085, main dimensions	55
5.8	NS 085, mounting flange	58
5.9	NS 085, shaft end	59
5.10	Through-drive	60
5.11	Multiple axial piston unit	64

1 Type code

Axial piston pump
LH30VO 028 to 085

1.	2.	3.	4.	5.	6.	7.	8.	9.	10.	11.	12.	13.	14.	15.	16.	17.	18.	19.	20.	21.
L	H	3	0	V	O	/		20	V					0	00		000			

1. Manufacturer

Liebherr Machines Bulle SA	L
----------------------------	---

2. Division

Hydraulics	H
------------	---

3. Nominal pressure range

Nominal pressure $p_N = 4,061$ psi (280 bar) / Maximum pressure $p_{max} = 4,641$ psi (320 bar)	3
--	---

4. Version

Single unit (pump) (multiple unit inline, see section 5.11)	0
--	---

5. Design

Variable	V
----------	---

6. Circuit

Open loop circuit	O
-------------------	---

7. Nominal size (NS)

NS (multiple unit inline, see section 5.11)	028	045	085	
--	-----	-----	-----	--

8. Control (3- / 6- or 9-digit)

1. Control axis	XX-
2. Control axis (combination control)	XX-XX-
3. Control axis (combination control)	XX-XX-XX-

Mechanical-hydraulic controls				
Pressure cut-off	■	■	■	DA-
Hydraulic pressure control (remotely controllable) / pressure cut-off (combination control)	■	■	■	DF-DA-
Load sensing control (without pressure-relief nozzle in control) / pressure cut-off (combination control)	▼	▼	▼	LS0DA-
Load sensing control (with pressure-relief nozzle in control) / pressure cut-off (combination control)	□	□	□	LS1DA-
Power control	■	■	■	LR-
A dash must be added as suffix for 2-digit mechanical-hydraulic controls. This applies to each control axis.				

1 Type code

Axial piston pump

LH30VO 028 to 085

	028	045	085	
Electro-hydraulic controls				
Electrical pressure control	▼	▼	▼	DE_
Load sensing control (without pressure-relief nozzle in control) / Electrical pressure control (combination control)	■	■	■	LS0DE_
Load sensing control (with pressure-relief nozzle in control) / Electrical pressure control (combination control)	□	□	□	LS1DE_
The underscore placeholder for electrical pressure controls is for the desired voltage / characteristic / plug. Please enter 1-8 instead of the underscore.				
Voltage / characteristic / plug: 24V, rising characteristic, Deutsch plug	■	■	■	1
Voltage / characteristic / plug: 24 V, falling characteristic, Deutsch plug	■	■	■	2
Voltage / characteristic / plug: 12V, rising characteristic, Deutsch plug	■	■	■	3
Voltage / characteristic / plug: 12V, falling characteristic, Deutsch plug	■	■	■	4
Voltage / characteristic / plug: 24V, rising characteristic, AMP plug	▼	▼	▼	5
Voltage / characteristic / plug: 24 V, falling characteristic, AMP plug	▼	▼	▼	6
Voltage / characteristic / plug: 12V, rising characteristic, AMP plug	■	■	■	7
Voltage / characteristic / plug: 12V, falling characteristic, AMP plug	■	■	■	8

Electrical volume control	■	■	■	VE_
Electrical volume control with jump function at signal loss	■	■	■	VK_
Volume electrically overridden (retarder)	■	■	■	VO_
The underscore placeholder for electrical volume flow controls is for the desired voltage / characteristic / plug. Please enter 1-7 instead of the underscore.				
Voltage / characteristic / plug: 24V, rising characteristic, Deutsch plug	□	□	□	1
Voltage / characteristic / plug: 12V, rising characteristic, Deutsch plug	□	□	□	3
Voltage / characteristic / plug: 24V, rising characteristic, AMP plug	■	■	■	5
Voltage / characteristic / plug: 12V, rising characteristic, AMP plug	□	□	□	7

Availability matrix for controls (1-3 control axes)

		Basic option										
		DA-	DE_	LS0DA-	LS1DA-	LS0DE_	LS1DE_	DF-DA-	DE_DA-	VE_	VK_	LR-
Additional option	None	■	▼	▼	□	■	□	■	■	■	■	■
	DA-	-	■	-	-	■	□	-	-	■	■	■
	VE_	■	■	■	□	■	□	■	■	-	-	-
	VK_	■	■	■	□	■	□	■	■	-	-	-
	LR-	■	-	■	□	■	□	■	■	-	-	-
	VO_	■	■	■	□	■	□	■	■	-	-	■

1 Type code

Axial piston pump

LH30VO 028 to 085

028

045

085

9. Series

Design	20
--------	----

10. Seal material

Viton	V
-------	---

11. Direction of rotation (looking at the face of the drive shaft)

Counterclockwise	■	■	■	L
Clockwise	■	■	■	R

12. Mounting flange

SAE B = 4.0 inch (101.6 mm) (SAE J744) 2-hole fastening	▼	▼	-	B2
SAE C = 5.0 inch (127.0 mm) (similar to SAE J744) 2+4-hole fastening	-	-	▼	C6

13. Driving shaft end

ANSI, 7/8", 13 teeth, with undercut	■	■	-	A1
ANSI, 7/8", 13 teeth, without undercut	▼	■	-	A2
ANSI, 1", 15 teeth, with undercut	□	■	-	A3
ANSI, 1", 15 teeth, without undercut	□	▼	-	A4
ANSI, 1 1/4", 14 teeth, with undercut	-	-	■	A5
ANSI, 1 1/4", 14 teeth, without undercut	-	-	□	A6
ANSI, 1 1/2", 17 teeth, with undercut	-	-	□	A9
ANSI, 1 1/2", 17 teeth, without undercut	-	-	▼	A0

14. Working connection

Metric fastening thread at the side ISO 6162-2 / SAE J518-2	□	■	▼	A1
Metric fastening thread at the rear ISO 6162-2 / SAE J518-2	□	■	■	A3
Metric fastening thread at the side ISO 6162-1 / SAE J518-1	▼	▼	-	B1
Metric fastening thread at the rear ISO 6162-1 / SAE J518-1	■	■	-	B3

15. Add-on parts

Without add-on parts	0
----------------------	---

16. Gear pump

Without gear pump	00
-------------------	----

1 Type code

Axial piston pump

LH30VO 028 to 085

028	045	085
-----	-----	-----

17. Through-drive

Without through-drive			■	■	▼	0000
Centering diameter	Shaft gearing	Fastening				
Ø3.25 (82.55) (SAE J744-A)	ANSI B92.1a 5/8 in 9T 16/32DP	2-hole/open hole	■	■	■	A11D
Ø3.25 (82.55) (SAE J744-A)	ANSI B92.1a 3/4 in 11T 16/32DP	2-hole/open hole	■	■	■	A21D
Ø4.00 (101.6) (SAE J744-B)	ANSI B92.1a 7/8 in 13T 16/32DP	2-hole/open hole	▼	■	■	B11D
Ø4.00 (101.6) (SAE J744-B)	ANSI B92.1a 1 in 15T 16/32DP	2-hole/open hole	-	▼	■	B21D
Ø5.00 (127) (SAE J744-C)	ANSI B92.1a 1 1/4 in 14T 12/24DP	2-hole/open hole	-	-	□	C11D
Ø5.00 (127) (SAE J744-C)	ANSI B92.1a 1 1/2 in 17T 12/24DP	2-hole/open hole	-	-	▼	C21D
Special / Centering diameter	No shaft coupling	4-hole/closed hole	▼	▼	▼	K02G

18. Valves

Without valve	000
---------------	-----

19. Sensors

Without sensor	▼	▼	▼	0
Preparation for pressure measuring connection (Minimes)	-	□	□	V

20. Swivel angle limit stops

Standard (without Q_{min} + Q_{max} limit stop)	▼	▼	▼	0
With Q_{max} fixed limit stop (please specify in purchase order)	□	□	□	5

21. Special design and options

Primer	▼	▼	▼	G
Primer + paint (color as specified by customer)	□	□	□	F
Conservation without primer (tank pump)	□	□	□	K
Additional Leakage oil connection	■	■	■	Z

- ▼ = Preferred series
- = Available
- = Available on request
- = Not possible



Note

Contact addresses for requests are listed on the reverse of this document.

2 Technical data

Axial piston pump
LH30VO 028 to 085

2.1 Table of values

Nominal size			028	045	085	
Displacement volume	$V_{g \max}$	inch ³ (cm ³)	1.75 (28.7)	2.84 (46.5)	5.25 (86.1)	
	$V_{g \min}$	inch ³ (cm ³)	0	0	0	
Volume flow at $V_{g \max}$ and n_{\max}		$q_{v \max}$	US.liq. gal/min (l/min)	25.02 (94.7)	36.85 (139.5)	54.58 (206.6)
Min. speed at $V_{g \max}$ and $p_{\text{abs}} = 14.5$ psi (1 bar) at the suction port		n_{\min}	rpm	100*	100*	100*
Max. speed at $V_{g \max}$ and $p_{\text{abs}} = 14.5$ psi (1 bar) at the suction port		n_{\max}	rpm	3,300	3,000	2,400
Torque at $V_{g \max}$ and $\Delta p = 4,061$ psi (280 bar)		M_{\max}	lb·ft (Nm)	94.33 (127.9)	152.82 (207.2)	283.00 (383.7)
Drive power at $q_{v \max}$ and $\Delta p = 4,061$ psi (280 bar)		P_{\max}	kW (hp)	59.27 (44.2)	87.30 (65.1)	129.27 (96.4)
Engine moment of inertia		J_{TW}	lb·ft ² (kgm ²)	0.047 (0.002)	0.095 (0.004)	0.230 (0.0097)
Weight without through-drive (approx.)		m	lb (kg)	35.27 (16)	46.30 (21)	85.98 (39)
Weight with through-drive (approx.)		m	lb (kg)	39.68 (18)	52.91 (24)	94.80 (43)
Torsional stiffness	Driving shaft code "A1"	lb·ft/rad (Nm/rad)		14,604 (19,800)	17,406 (23,600)	-
	Driving shaft code "A2"			15,931 (21,600)	20,357 (27,600)	-
	Driving shaft code "A3"			□	23,602 (32,000)	-
	Driving shaft code "A4"			□	24,044 (32,600)	-
	Driving shaft code "A5"			-	-	51,482 (69,800)
	Driving shaft code "A6"			-	-	59,521 (80,700)
	Driving shaft code "A9"			-	-	□
	Driving shaft code "A0"			-	-	76,190 (103,300)

□ = Available on request

- = Not possible

*) Depending on the specific application, special approval for a lower minimum speed at lower operating pressure is possible. Please contact Liebherr, stating your expected load cycle.



Note

Theoretical, rounded values which do not take into account the efficiency, tolerances, contamination of the hydraulic fluid, and deflection of the driving shaft.

2 Technical data

Axial piston pump
LH30VO 028 to 085

2.2 Maximum radial and axial force load on the driving shaft



Note

The radial and axial forces are calculated separately and for stated load cycles (pressure and direction of force). If you are planning a belt drive, or expect continuous axial and/or radial forces, please contact Liebherr stating the anticipated load cycle.



Note

Theoretical, rounded values which do not take into account the efficiency, tolerances, contamination of the hydraulic fluid, and deflection of the driving shaft.

Generally applicable information for calculation

- $V_{g_{max}}$
- Operating pressure pHD: 2,901 psi (200 bar)

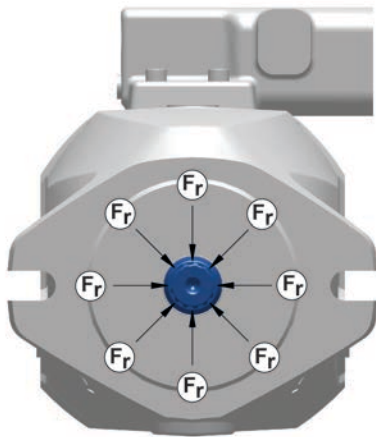

DB-LH30VO-113

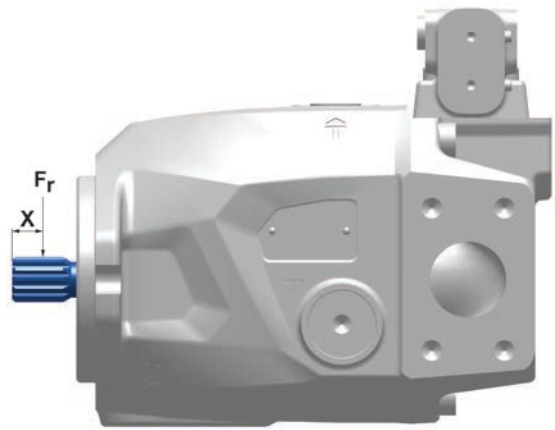

DB-LH30VO-114

Nominal size			028	045	085
X		inch (mm)	0.49 (12.5)	0.59 (15)	0.71 (18)
Position of radial force application		-	All		
Max. radial force F_r	Reduction of LLD* by 20%	lbf (N)	112.40 (500)	146.12 (650)	348.44 (1,550)
	Reduction of LLD* by 50%		314.72 (1,400)	292.24 (1,300)	629.44 (2,800)

LLD*) Bearing service life

2 Technical data

Axial piston pump
LH30VO 028 to 085

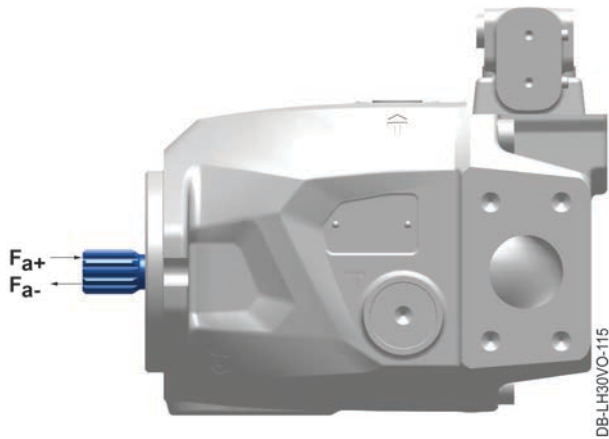

Nominal size			028	045	085
Max. axial force F_{a+}	Reduction of LLD* by 20%	lbf (N)	22.48 (100)	22.48 (100)	112.40 (500)
	Reduction of LLD* by 50%		67.44 (300)	112.40 (500)	269.76 (1,200)
Max. axial force F_{a-}	Reduction of LLD* by 20%	lbf (N)	427.12 (1,900)	348.44 (1,550)	606.96 (2,700)
	Reduction of LLD* by 50%		517.04 (2,300)	494.56 (2,200)	899.20 (4,000)

LLD*) Bearing service life

2.3 Maximum input and through-drive torques



Note

Theoretical, rounded values which do not take into account the efficiency, tolerances, contamination of the hydraulic fluid, and deflection of the driving shaft.

Generally applicable information for calculation

- $V_{g_{max}}$
- Operating pressure pHD: 4,061 psi (280 bar)

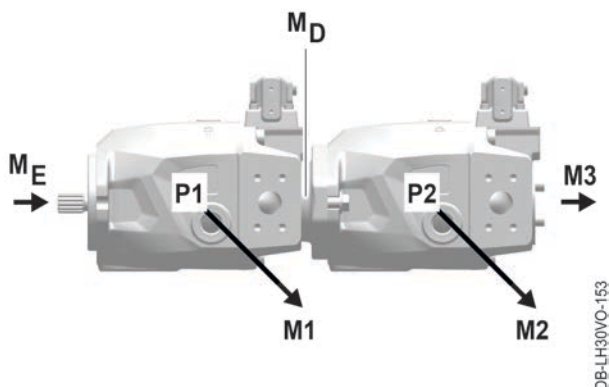

2 Technical data

Axial piston pump
LH30VO 028 to 085

M1	Torque, axial piston pump 1
M2	Torque, axial piston pump 2
M3	Torque, axial piston pump 3
P1	Axial piston pump 1

P2	Axial piston pump 2
M_E^1	Input torque
M_D^2	Through-drive torque
-	-

1) $M_E = M1 + M2 + M3$
 $M_E < M_{E \max}$

2) $M_D = M2 + M3$
 $M_D < M_{D \max}$

Nominal size			028	045	085		
Torque* at $V_{g \max}$ and $\Delta p = 4,061 \text{ psi (280 bar)}$			M_{\max}	lbf ft (Nm)	94 (128)	153 (207)	283 (384)
Max. torque from driving shaft input (installed without shear force)	A1	7/8", 13 teeth, with undercut	$M_{E \max}$	lbf ft (Nm)	173 (235)	173 (235)	-
	A2	7/8", 13 teeth, without undercut	$M_{E \max}$	lbf ft (Nm)	207 (280)	207 (280)	-
	A3	1", 15 teeth, with undercut	$M_{E \max}$	lbf ft (Nm)	273 (370)	273 (370)	-
	A4	1", 15 teeth, without undercut	$M_{E \max}$	lbf ft (Nm)	330 (447)	330 (447)	-
	A5	1 1/4", 14 teeth, with undercut	$M_{E \max}$	lbf ft (Nm)	-	-	498 (675)
	A6	1 1/4", 14 teeth, without undercut	$M_{E \max}$	lbf ft (Nm)	-	-	579 (785)
	A9	1 1/2", 17 teeth, with undercut	$M_{E \max}$	lbf ft (Nm)	-	-	944 (1280)
	A0	1 1/2", 17 teeth, without undercut	$M_{E \max}$	lbf ft (Nm)	-	-	1090 (1478)
Max. torque of through drive			$M_{D \max}$	Nm	117 (158)	221 (300)	392 (532)

- = Available on request
- = Not possible

2 Technical data

Axial piston pump
LH30VO 028 to 085

2.4 Direction of rotation

1.	2.	3.	4.	5.	6.	7.	8.	9.	10.	11.	12.	13.	14.	15.	16.	17.	18.	19.	20.	21.
L	H	3	0	V	O		/		20	V				0	00		000			

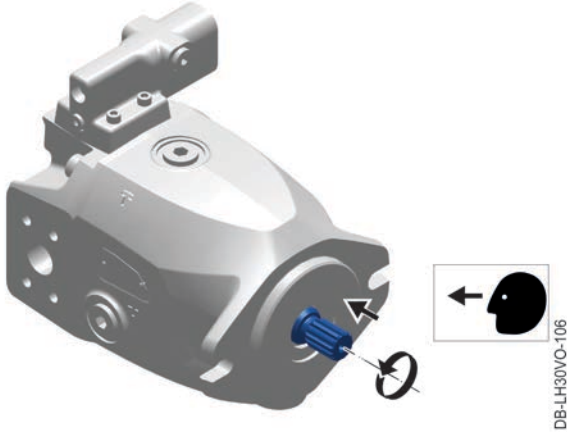

The direction of rotation is stated looking at the driving shaft as shown in the figure.

- R** right = clockwise
- L** left = counterclockwise

2.5 Permissible pressure range

2.5.1 Operating pressure

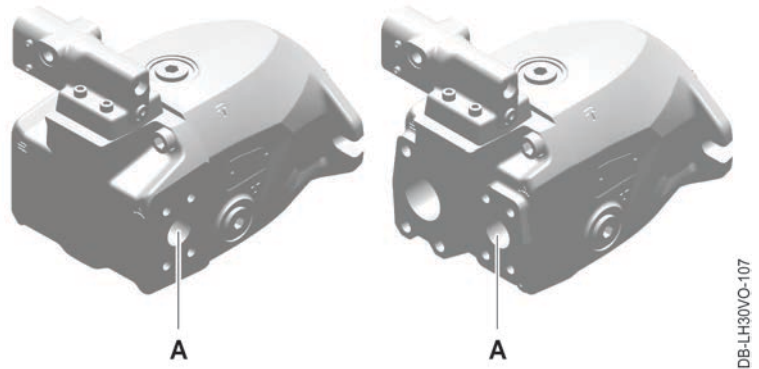
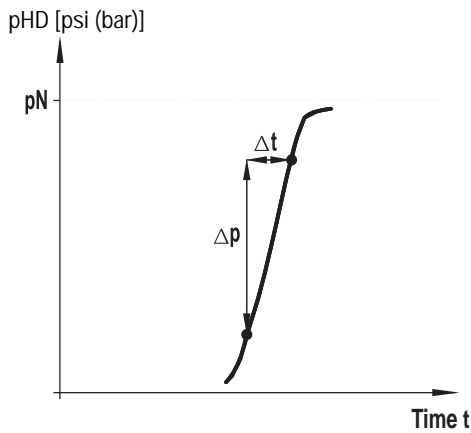

Operating pressure at connection A			028	045	085
Nominal size					
Minimum pressure ¹	pHD _{min}	psi (bar)	232 (16)		
Nominal pressure (fatigue-resistant)	pHD _N	psi (bar)	4,061 (280)		
Maximum pressure (individual active duration)	pHD _{max}	psi (bar)	4,641 (320)		
Individual active duration maximum pressure pHD _{max}	t	s	< 1		
Total active duration of maximum pressure pHD _{max}	t	Op.h*	300**		
Pressure change speed	RA	psi/s (bar/s)	246,564 (17,000)		

*) Op.h = Operating hours

1) In the working circuit there must be a minimum pressure at connection A to ensure sufficient lubrication in the engine during operation at all swivel angles.

2 Technical data

Axial piston pump
LH30VO 028 to 085

***) if not otherwise indicated



DANGER
Failure of the fastening bolts at working connection A!
Risk of fatal injury.
Use fastening bolts of strength class 10.9.

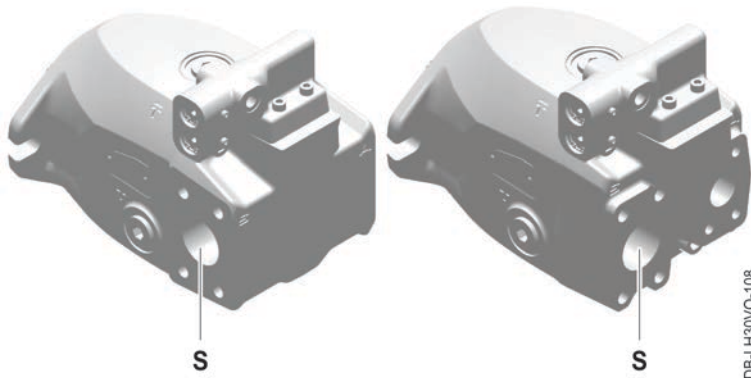

Suction pressure at connection S			
Nominal size	028 to 085		
Minimum pressure, absolute	pS _{min}	psi (bar)	11.60* (0.8)
Maximum pressure, absolute	pS _{max}	psi (bar)	29* (2)

*) deviating values on request

2 Technical data

Axial piston pump
LH30VO 028 to 085

2.5.2 Housing pressure, leakage oil pressure

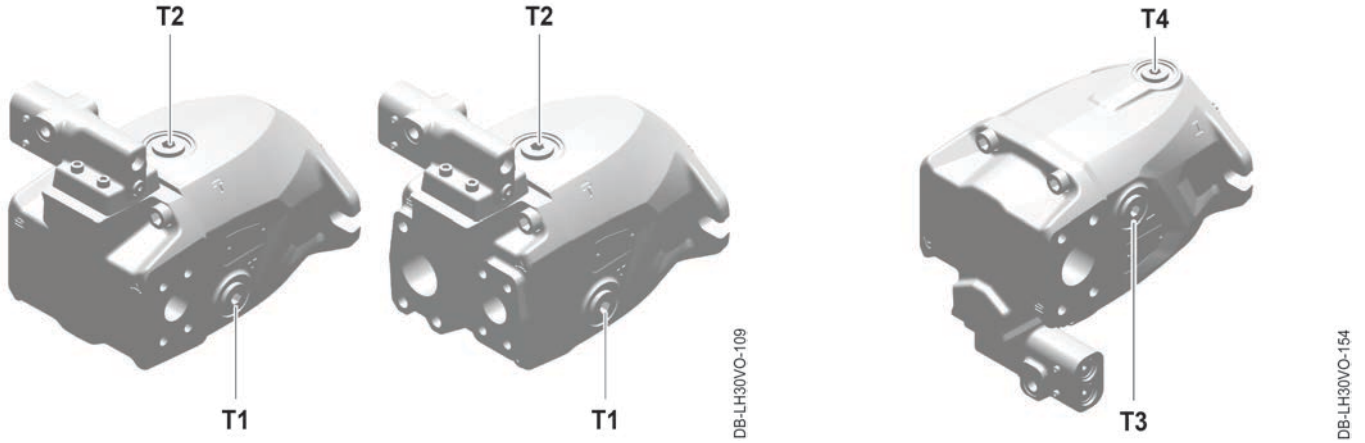

*) Leakage oil connection T4 can be ordered as a special design. [For further information, see: Type code](#)

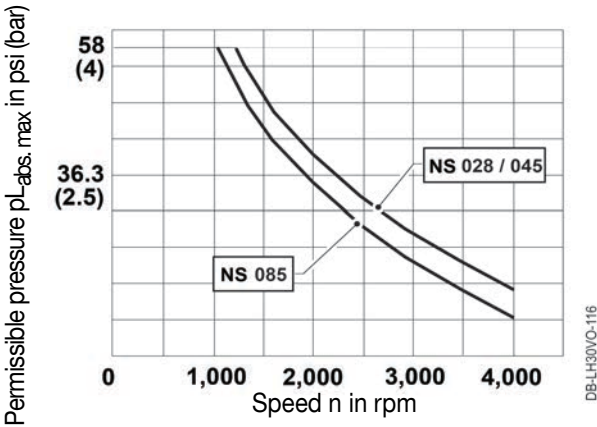

Leakage oil pressure at connection T1 / T2			
Nominal size	028 to 085		
Maximum pressure, absolute	pL _{max}	psi (bar)	29* (2)

*) The housing or leakage oil pressure pL must not exceed the suction pressure at connection S + 7.25 psi (0.5 bar) in any operating state.

$$pL \leq pS_{\max} + 7.25 \text{ psi (0.5 bar)}$$



Note

The pressure in the axial piston unit must always be higher than the outside pressure on the shaft sealing ring.

2 Technical data

Axial piston pump
LH30VO 028 to 085

2.6 Shaft sealing ring

2.6.1 General information

Rotary shaft lip seals are special sealing elements that allow a specific housing pressure. To ensure that the tribological system works optimally, the operating conditions must be met.

The sealing edge temperature varies due to the following factors in the housing:

- Circumferential speed
- Hydraulic fluid temperature
- Lubricant
- Pressure build-up

The sealing edge temperature can be 68 °F to 104 °F (20 °C to 40 °C) above the leakage oil temperature of a hydraulic axial piston unit.

2.6.2 Temperature range

The FKM rotary shaft lip seal is approved for leakage oil temperatures from -13 °F to +239 °F (-25 °C to +115 °C). For specific applications below -13 °F (-25 °C): Please contact us.

2.7 Hydraulic fluids

2.7.1 General information

The selection of the suitable hydraulic fluid is determined by the expected operating temperature as a function of the ambient temperature, which is equivalent to the tank temperature.

CAUTION

Mixing different mineral oil hydraulic fluids is prohibited!

Minimum required quality

Specification
LH-00-HYC3A
LH-00-HYE3A



Note

For further information, see: www.liebherr.com (brochure: Lubricants and operating fluids).
Alternatively: Contact lubricants@liebherr.com.

2 Technical data

Axial piston pump
LH30VO 028 to 085

2.7.2 Fill quantity

Nominal size		028	045	085
Fill quantity	US.liq.gal (liters)	0.15 (0.55)	0.16 (0.6)	0.42 (1.6)



Note

Before commissioning, the hydraulic unit must be filled with oil and vented. This must be checked during operation and after long periods of standstill and must be repeated if necessary!

2.7.3 Filtering

- To maintain the required cleanliness class "21/17/14 according to ISO 4406" under all circumstances, it is necessary to filter the hydraulic fluid.
- Filtering of the hydraulic fluid is achieved by the device-specific use of oil filters in the hydraulic system.
- The cleaning and maintenance intervals of the oil filters, and of the entire oil circuit, depend on use of the device; please see the device-specific operating instructions.

2.7.4 Limits of use

CAUTION

Temperatures ≤ -40 °F (-40 °C) in the system = The axial piston unit must not be operated. Preheat the axial piston unit to at least -40 °F (-40 °C).

Phase	Temperature [°F (°C)]**	Viscosity [inch ² /s (mm ² /s)]*
Cold-start phase	-40 to -13 °F (-40 to -25 °C)	2.48-1.55 (1,600-1,000)
Warm-up phase	Warmer than -13 °F (-25 °C)	1.55-0.775 (1,000-500)
Normal operation		< 0.775 (500)

*) depending on the hydraulic fluid used

***) relative to the tank temperature



Note

Optimal range of use: 0.025-0.056 inch²/s (16-36 mm²/s)

At the maximum leakage oil temperature, the viscosity must not drop below 0.012 inch²/s (8 mm²/s) (short-term, i.e., < 3 min., 0.011 inch²/s (7 mm²/s)).

2 Technical data

Axial piston pump
LH30VO 028 to 085

- Cold-start phase:

CAUTION

During the cold-start phase, the following operating conditions must be met:

- Operating pressure: $pHD_{min} < pHD_{coldstart} < 435 \text{ psi (30 bar)}$
- Speed $n_{coldstart} \leq 1,000 \text{ rpm}$

Start the drive motor and operate the axial piston unit at the stated operating conditions until a temperature of at least -13 °F (-25 °C) is reached.

- Warm-up phase:

CAUTION

During the warm-up phase, the following operating conditions must be met:

- Operating pressure range: $pHD_{min} < pHD_{warmup} < 50\% \text{ of } pHD_N$
- Speed $n_{warmup} \leq 50\% \text{ of } n_{max}$

Start the drive motor and operate the axial piston unit with the stated operating conditions until a viscosity of approx. $0.775 \text{ inch}^2/\text{s (500 mm}^2/\text{s)}$ is reached.

- Normal operation:



Note

No restrictions of the operating data.

3 Actuation and control type

Axial piston pump
LH30VO 028 to 085

3.1 Control types

1.	2.	3.	4.	5.	6.	7.	8.	9.	10.	11.	12.	13.	14.	15.	16.	17.	18.	19.	20.	21.
L	H	3	0	V	O	/	8	20	V					0	00		000			



Note

For each control type or function, only one nominal size is illustrated, typically based on the nominal size 045. Special applications and custom designs are not described in this section. Always use the information from the supplied installation drawing or contact Liebherr.

The following applies to all control types:



DANGER

The spring-loaded reset in the control valve is not a safety device!

Contamination in the hydraulic system, such as abrasion or residual dirt from equipment or system components, can cause blockages in undefined points of various control components.

Under certain circumstances, it may no longer be possible to implement the machine operator's settings. The implementation of a safety device, e.g., for an emergency stop, is the responsibility of the device or system manufacturer.



DANGER

The control valve is not an overload safety device!

The implementation of an overload safety device, e.g., a pressure limiting valve, is the responsibility of the device or system manufacturer.

Pressure limiting valves are included in our portfolio and can be ordered separately; please add your requirements in free text.

The following modular control types can be ordered for the LH30VO model series:

3.1.1 Mechanical-hydraulic controls

- DA- control, [see section 3.2.1](#)
- DF-DA- control, [see section 3.2.2](#)
- LSODA- control, [see section 3.2.3](#)

3.1.2 Electro-hydraulic controls

- DE1/3/5/7 control, rising characteristic, [see section 3.2.4](#)
- DE2/4/6/8 control, falling characteristic, [see section 3.2.5](#)
- LSODE1/3/5/7 control, rising characteristic, [see section 3.2.6](#)
- LSODE2/4/6/8 control, falling characteristic, [see section 3.2.7](#)
- VE1/3/5/7 control, rising characteristic, [see section 3.2.8](#)
- VO1/3/5/7 control, [see section 3.2.9](#)

Other control types on request.

3 Actuation and control type

Axial piston pump
LH30VO 028 to 085

3.2 Standard hydraulic diagrams

3.2.1 DA- - Pressure cut-off

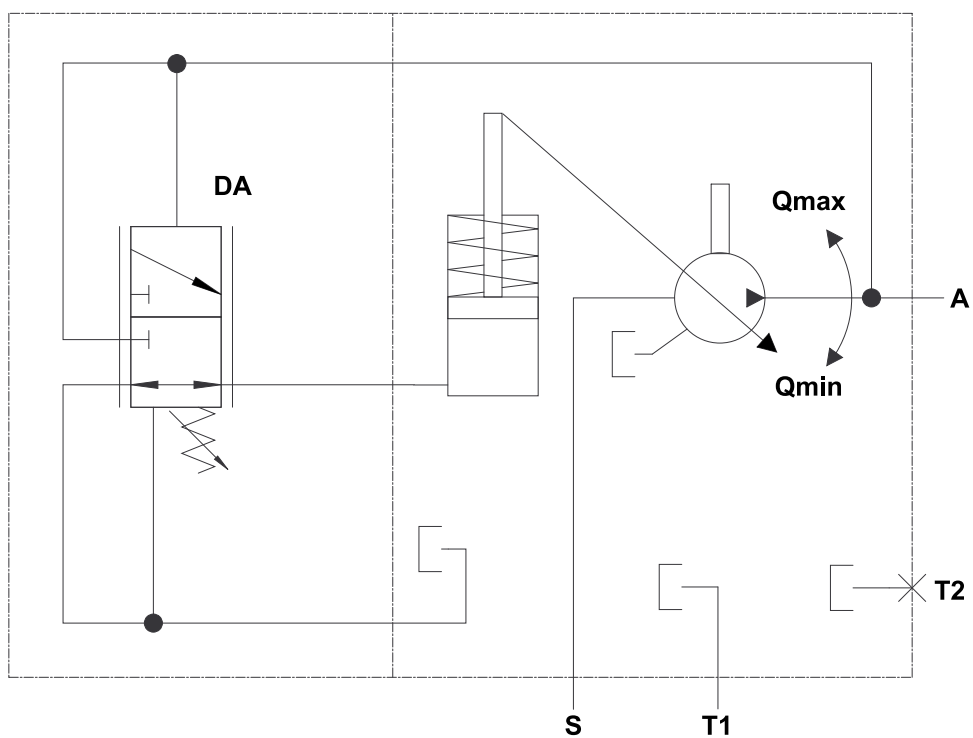

DA-
DB-LH30VO-056

A	Working connection ISO 6162-1/-2 (SAE J518)	T1, T2	Leakage oil connections ISO 11926
S	Suction port ISO 6162-1/-2 (SAE J518)	-	-

3 Actuation and control type

Axial piston pump
LH30VO 028 to 085

3.2.2 DF-DA- - Hydraulic pressure control, remotely controllable with pressure cut-off

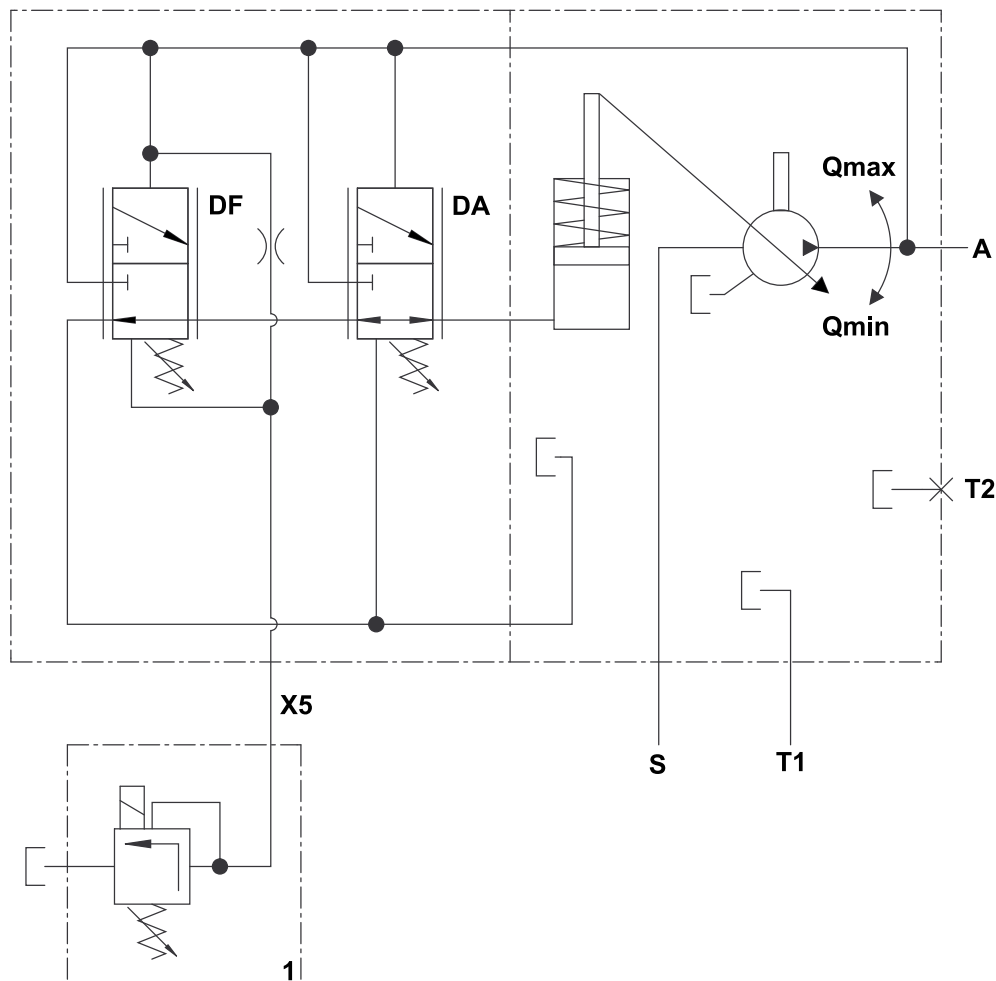

DF-DA-

DB-LH30VO-036

A	Working connection ISO 6162-1/-2 (SAE J518)	T1, T2	Leakage oil connections ISO 11926
S	Suction port ISO 6162-1/-2 (SAE J518)	X5	DF pressure ISO 9974-1-M12x1.5
1	Pressure limiting valve not included in scope of delivery	-	-

3 Actuation and control type

Axial piston pump
LH30VO 028 to 085

3.2.3 LS0DA- - Load sensing + pressure cut-off

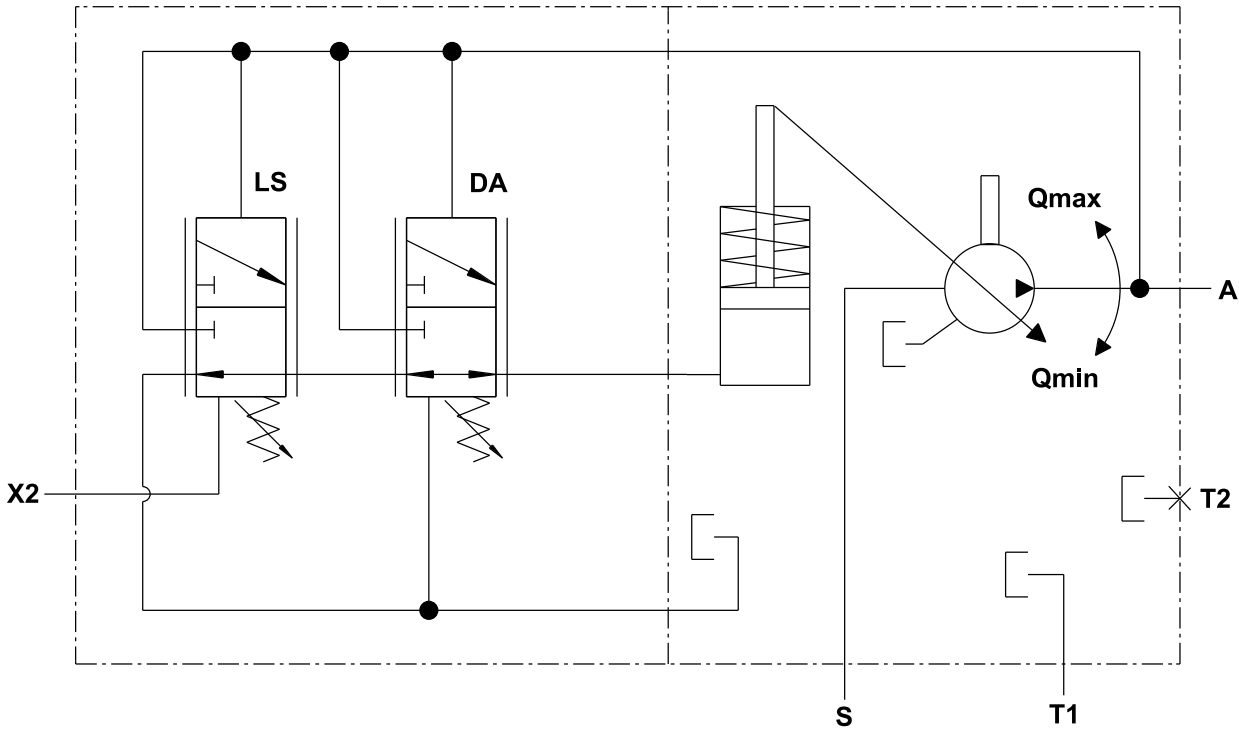

LS0DA-

DB-LH30VO-003

A	Working connection ISO 6162-1/-2 (SAE J518)	T1, T2	Leakage oil connections ISO 11926
S	Suction port ISO 6162-1/-2 (SAE J518)	X2	LS pressure ISO 9974-1



Note

The orifice required for the LS function to generate the pressure drop is not included in the axial piston unit's scope of delivery.

3 Actuation and control type

Axial piston pump
LH30VO 028 to 085

3.2.4 DE_ - Electrical pressure control, rising characteristic (DE1/3/5/7)

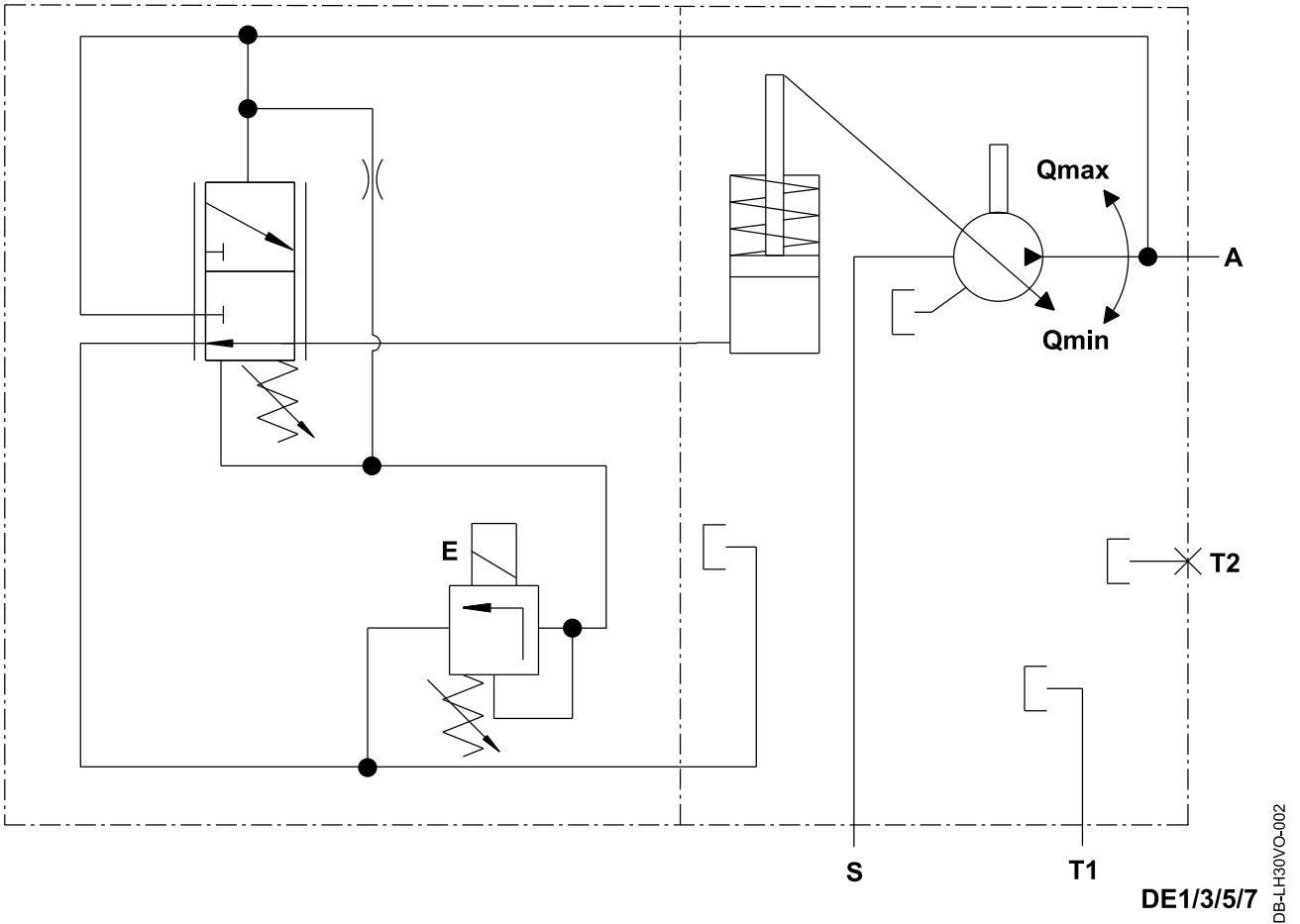

A	Working connection ISO 6162-1/-2 (SAE J518)	T1, T2	Leakage oil connections ISO 11926
S	Suction port ISO 6162-1/-2 (SAE J518)	E	_1 / _3: Deutsch plug DT04-2P 2-pin _5 / _7: AMP plug Junior Timer 2-pin

3 Actuation and control type

Axial piston pump
LH30VO 028 to 085

3.2.5 DE_ - Electrical pressure control, falling characteristic (DE2/4/6/8)

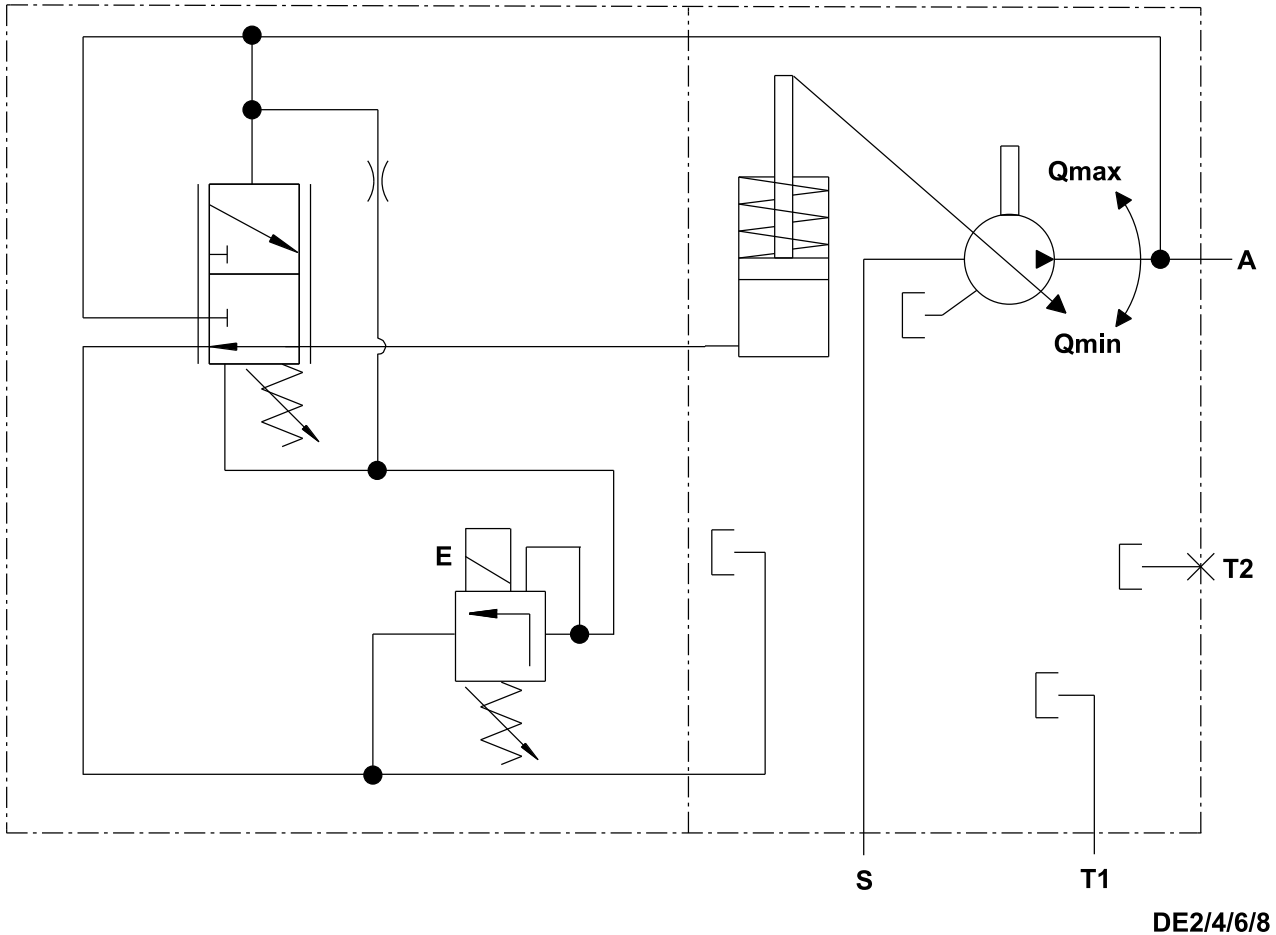

DB-LH30VO-001

A	Working connection ISO 6162-1/-2 (SAE J518)	T1, T2	Leakage oil connections ISO 11926
S	Suction port ISO 6162-1/-2 (SAE J518)	E	_2 / _4: Deutsch plug DT04-2P 2-pin _6 / _8: AMP plug Junior Timer 2-pin

3 Actuation and control type

Axial piston pump
LH30VO 028 to 085

3.2.6 LS0DE_ - Load sensing + electrical pressure control, rising characteristic (LS0DE1/3/5/7)

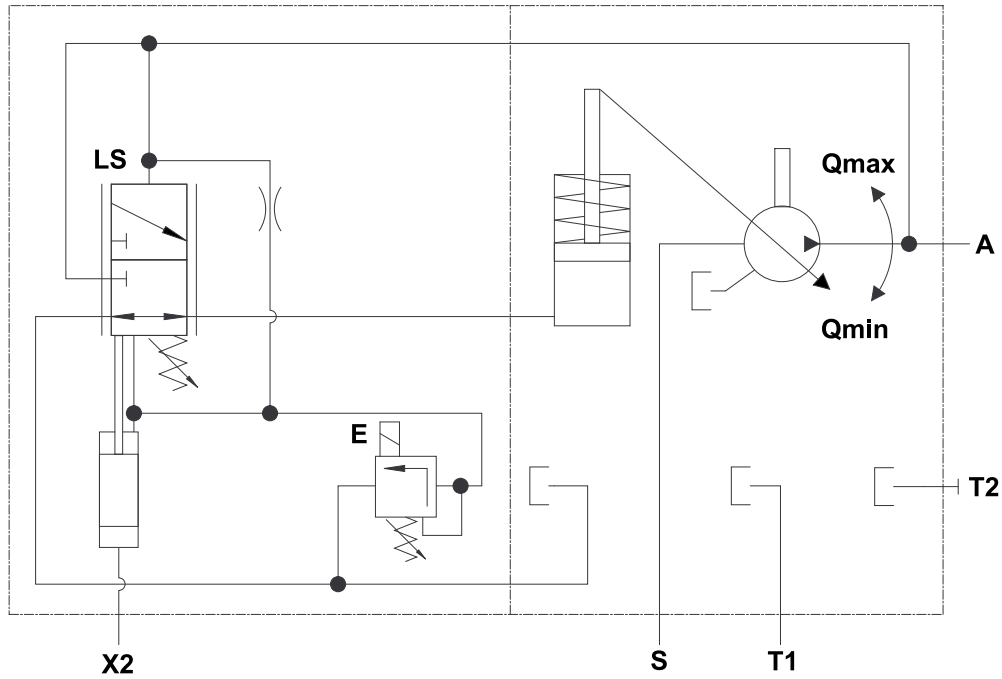

LS0DE1/3/5/7

DB-LH30VO-061

A	Working connection ISO 6162-1/-2 (SAE J518)	T1, T2	Leakage oil connections ISO 11926
S	Suction port ISO 6162-1/-2 (SAE J518)	X2	LS pressure ISO 9974-1
E	1 / _3: Deutsch plug DT04-2P 2-pin _5 / _7: AMP plug Junior Timer 2-pin	-	-

3 Actuation and control type

Axial piston pump
LH30VO 028 to 085

3.2.7 LS0DE_ - Load sensing + electrical pressure control, falling characteristic (LS0DE2/4/6/8)

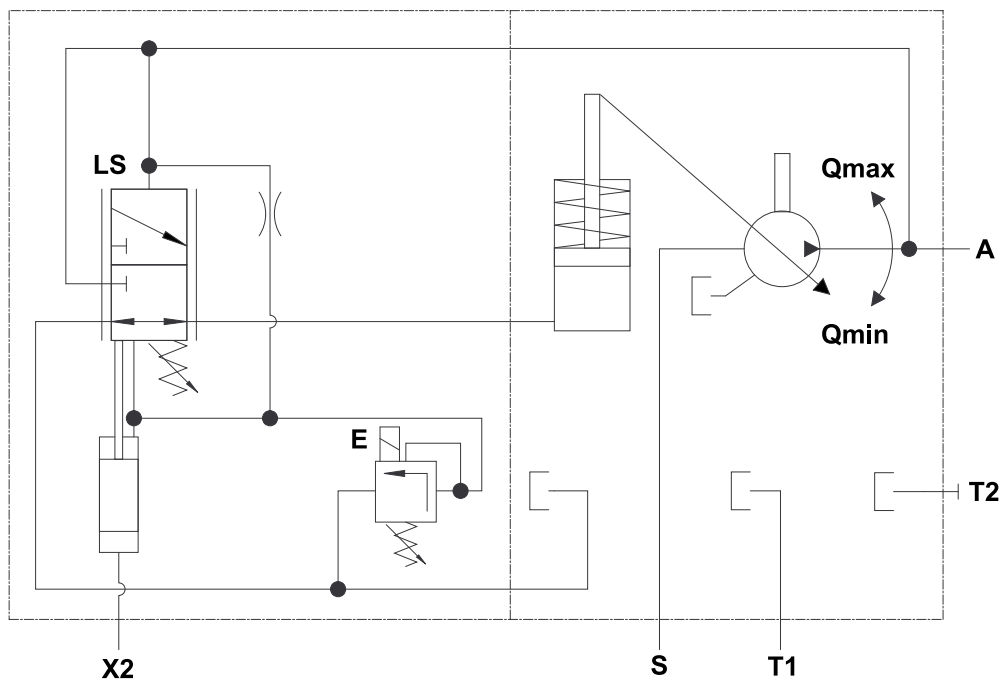

LS0DE2/4/6/8

DB-LH30VO-060

A	Working connection ISO 6162-1/-2 (SAE J518)	T1, T2	Leakage oil connections ISO 11926
S	Suction port ISO 6162-1/-2 (SAE J518)	X2	LS pressure ISO 9974-1
E	_2 / _4: Deutsch plug DT04-2P 2-pin _6 / _8: AMP plug Junior Timer 2-pin	-	-

3 Actuation and control type

Axial piston pump
LH30VO 028 to 085

3.2.8 VE_ - Electrical volume control, rising characteristic (VE1/3/5/7)

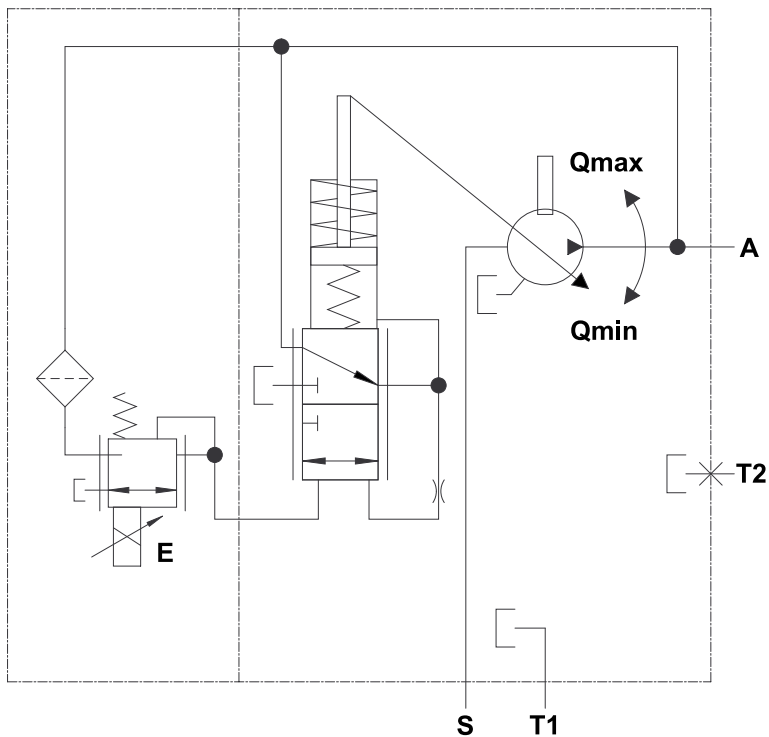

VE1/3/5/7

DB-LH30VO-058

A	Working connection ISO 6162-1/-2 (SAE J518)	T1, T2	Leakage oil connections ISO 11926
S	Suction port ISO 6162-1/-2 (SAE J518)	E	_1 / _3: Deutsch plug DT04-2P 2-pin _5 / _7: AMP plug Junior Timer 2-pin

3 Actuation and control type

Axial piston pump
LH30VO 028 to 085

3.2.9 VO_ - Retarder (VO1/3/5/7)

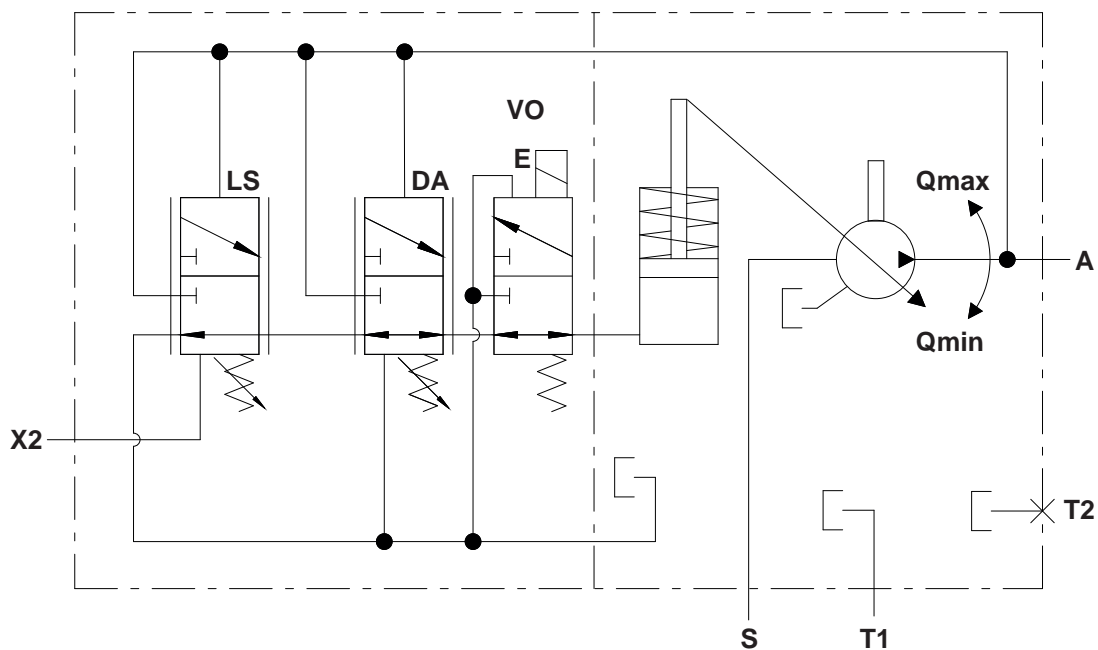

VO1/3/5/7

DB-LH30VO-141

A	Working connection ISO 6162-1/-2 (SAE J518)	X2	LS pressure ISO 9974-1
S	Suction port ISO 6162-1/-2 (SAE J518)	T1, T2	Leakage oil connections ISO 11926
E	_1 / _3: Deutsch plug DT04-2P 2-pin _5 / _7: AMP plug Junior Timer 2-pin	-	-

3 Actuation and control type

Axial piston pump
LH30VO 028 to 085

3.3 Control functions

- DA- function / pressure cut-off, [see section 3.3.1](#)
- DF- function / hydraulic pressure control, remotely controllable, [see section 3.3.2](#)
- LS0- function / load sensing without vent nozzle in the control, [see section 3.3.3](#)
- LR- function, power control, [see section 3.3.4](#)
- DE1/3/5/7- function / pressure control, rising characteristic, [see section 3.3.5](#)
- DE2/4/6/8- function / pressure control, falling characteristic, [see section 3.3.6](#)
- VE1/3/5/7- function, rising characteristic, [see section 3.3.7](#)
- VK1/3/5/7- function, rising characteristic, [see section 3.3.8](#)
- VO1/3/5/7- function, retarder, [see section 3.3.9](#)

3.3.1 DA- function

Characteristic curve

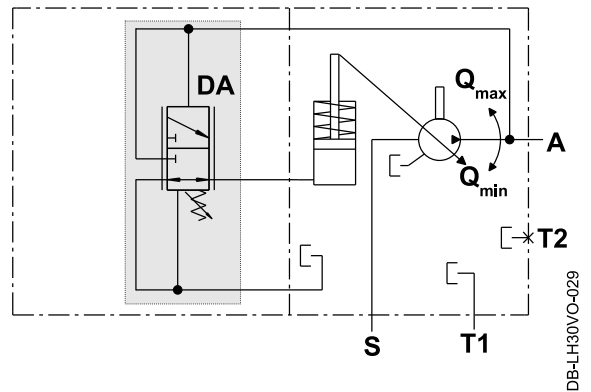
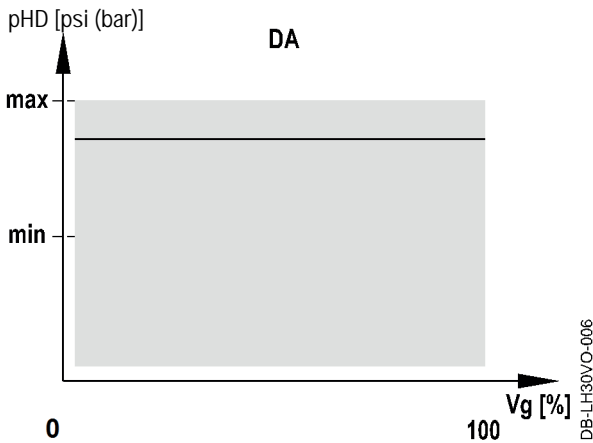

Additional technical data

DA adjustment range	2,176-4,061 psi* (150-280 bar)
---------------------	--------------------------------

*) depending on requirement

The DA pressure control limits the maximum high pressure of the axial piston unit in the control range. When a fixed, preset high pressure value pHD is reached, the axial piston unit swings in the direction of $V_{g \min}$ and protects the hydraulic system against damage and overload. It swings in the direction of $V_{g \min}$ until the volume flow that is generated matches the fixed, preset high pressure value pHD.

Once the system pressure drops below the fixed, preset high pressure value pHD, the axial piston unit swings up to $V_{g \max}$.

3 Actuation and control type

Axial piston pump
LH30VO 028 to 085

3.3.2 DF- function

Characteristic curve

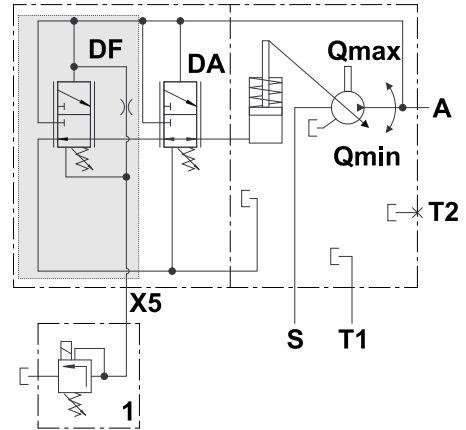
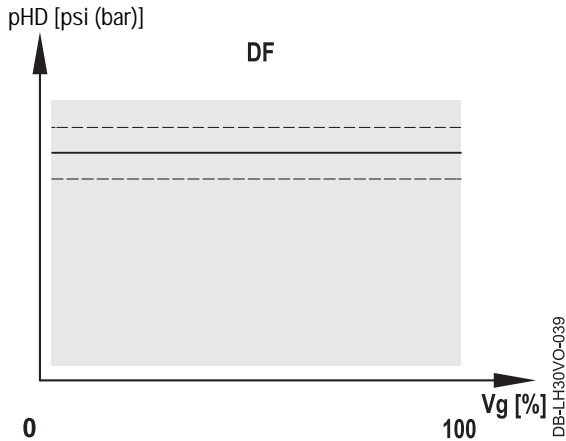

DB-LH30VO-040

Additional technical data

Adjustment range Δp	203-363 psi* (14-25 bar)
-----------------------------	--------------------------

*) depending on requirement

The DF function can only be ordered in combination with the DA function for safety reasons.

The remote control can limit the system pressure via an external pressure limiting valve* (No. 1). The DF- pressure control provides a fixed, preset pressure differential Δp .

Any system pressure below the fixed DA- cut-off pressure can be set as the sum of the set pressure value of the external pressure limiting valve and the Δp of the DF- pressure control. For further information: see section 3.3.1.

If the X5 connection to the tank is vented, the pump operates in standby mode. This is useful for ramping up the axial piston unit from idle state.

*) not included in the scope of delivery



Note

The DF function can only be ordered in combination with the pressure cut-off (DA-).

3 Actuation and control type

Axial piston pump
LH30VO 028 to 085

3.3.3 LS0- function

Characteristic curve

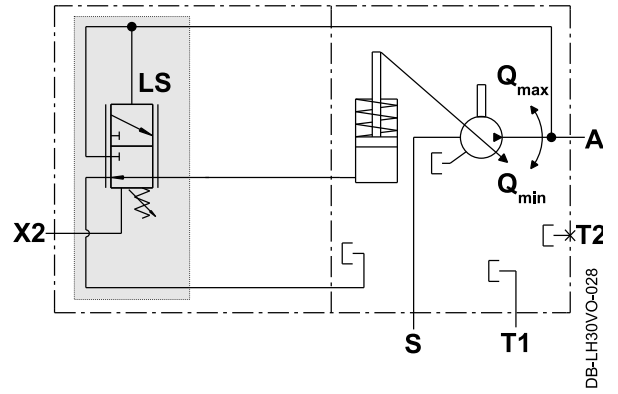
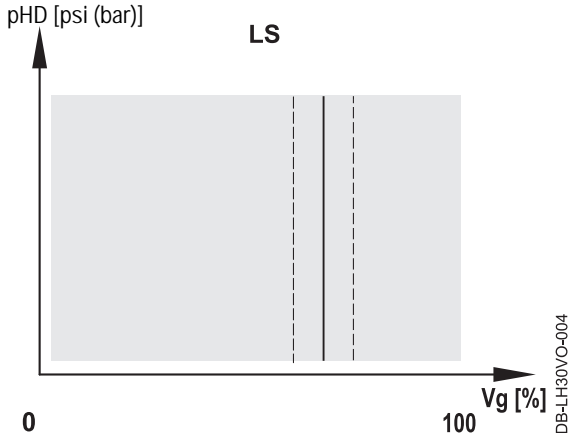

Additional technical data

LS pressure adjustment range	Δp	203-363 psi* (14-25 bar)
------------------------------	------------	--------------------------

*) depending on requirement

Load sensing systems, such as in an LS0DA control, can be used to further improve the dynamic properties of the control system for variable displacement axial piston pumps. By adjusting the volume flow to the current requirements of one or more consumers, the LS0 function is designed as a load pressure sensing system. It reduces performance losses compared to control functions that deliver at maximum flow rate despite volume flow requirements being lower.

At an external adjustable orifice plate, the pressure difference Δp between the highest LS pressure occurring in the system (controlled by shuttle valves in case of several consumers) and the high pressure pHD is compared and kept in equilibrium by the pressure compensator (LS axis) by adapting to the demand from the consumers. The LS pressure depends on spring force and is therefore adjustable.

If there is no demand from the consumers, the axial piston unit controls in the direction of $V_{g \text{ min}}$ until the value corresponds to the set LS pressure.

As the consumer demand increases (increasing Δp at the orifice), the axial piston unit controls in the direction of $V_{g \text{ max}}$ until the working pressure pHD corresponds to the sum of the consumer demand-dependent LS pressure + Δp .



Note

The LS function can only be ordered in combination with the pressure cut-off (DA-) or the electrical pressure control DE_.

3 Actuation and control type

Axial piston pump
LH30VO 028 to 085

3.3.4 LR- function

The swivel angle is controlled as a function of the load-dependent operating pressure pHD such that the maximum torque permitted by the drive motor is not exceeded at constant speed.

Characteristic curve

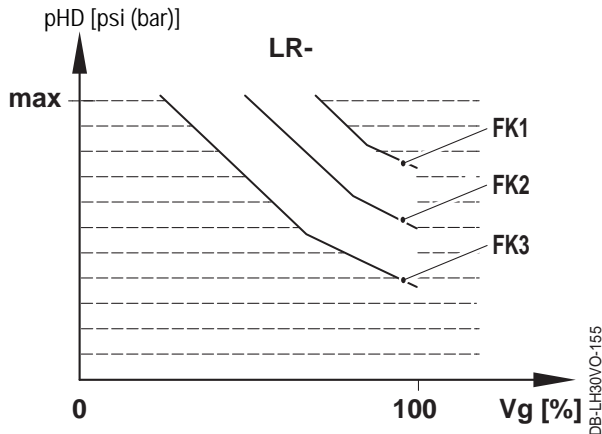

The LR function prevents the maximum available mechanical drive power being exceeded by the axial piston unit.

Below the spring characteristic (FK1 to FK3) the cradle spring pushes the axial piston unit to the largest swivel angle, $V_{g \max}$. As the operating pressure pHD increases, the axial piston unit swings back in the direction of $V_{g \min}$ when the start of control value is reached.



Note

Liebherr recommends combining the LR- function with a pressure control.

FK1, FK2 and FK3 are currently available spring characteristics which are specially designed for different applications and are preset during assembly. In order to select the right spring characteristic, the desired start of control in pHD [psi (bar)] at the maximum swivel angle must be specified in the order in free text.

3 Actuation and control type

Axial piston pump
LH30VO 028 to 085

3.3.5 DE- function, rising characteristic (DE1/3/5/7)

Characteristic curve

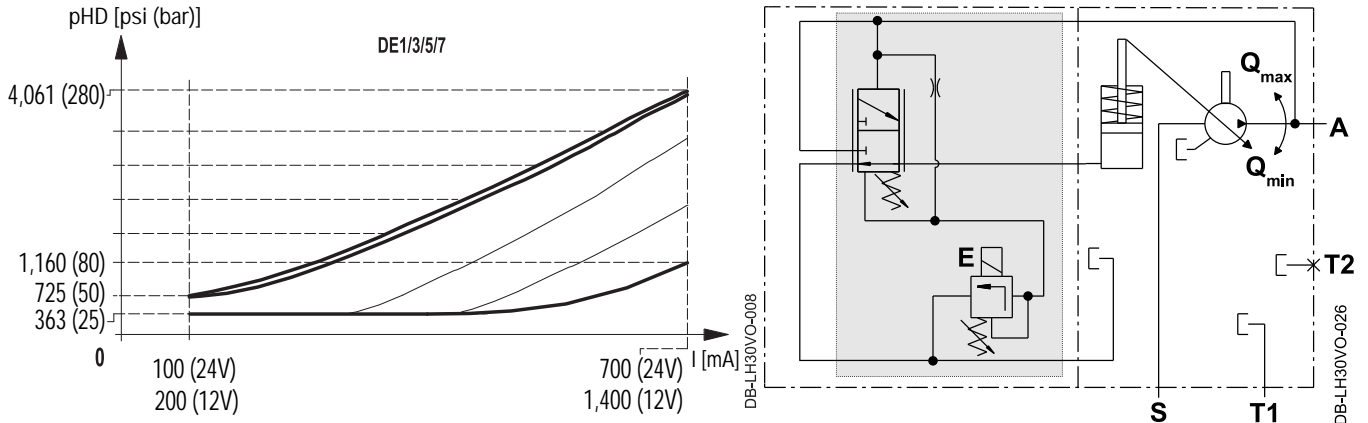

Additional technical data

Resulting start of control	max	725 psi (50 bar)
	min	363 psi (25 bar)
Adjustment range, end of control	max	4,061 psi (280 bar)
	min	1,160 psi (80 bar)
Standby pressure pStbyD* at $\Delta p = 290$ psi (20 bar)		363-725 psi (25-50 bar)



Note

Technical data of proportional magnet, see section 3.4.

The DE- function is an electronic pressure control the pressure level of which can be continuously adjusted by a defined, variable magnetic field at the proportional magnet.

The pump is kept at $V_{g \max}$ by a spring. The high pressure is routed to a proportional pressure limiting valve by a pressure compensator. When the opening pressure is reached, the pump's pressure control valve switches and the high pressure swings the pump in direction $V_{g \min}$, until the pressure level in the system is again below the proportional pressure limiting valve's set value.

If the magnetic field at the proportional magnet is reduced, the axial piston unit swings in the direction of $V_{g \min}$; if the magnetic field stops completely, the unit self-regulates to standby pressure (pStby).

3 Actuation and control type

Axial piston pump
LH30VO 028 to 085

3.3.6 DE- function, falling characteristic (DE2/4/6/8)

Characteristic curve

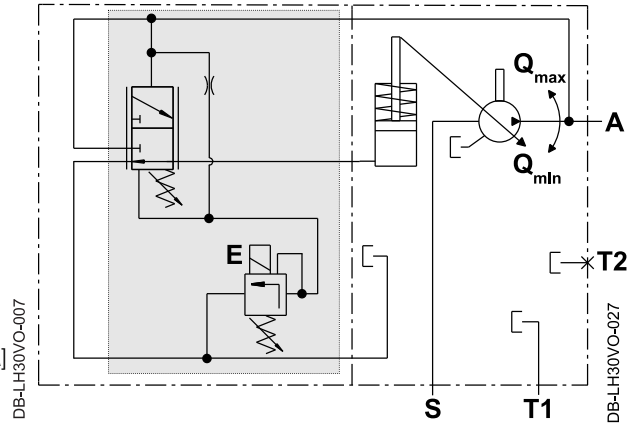
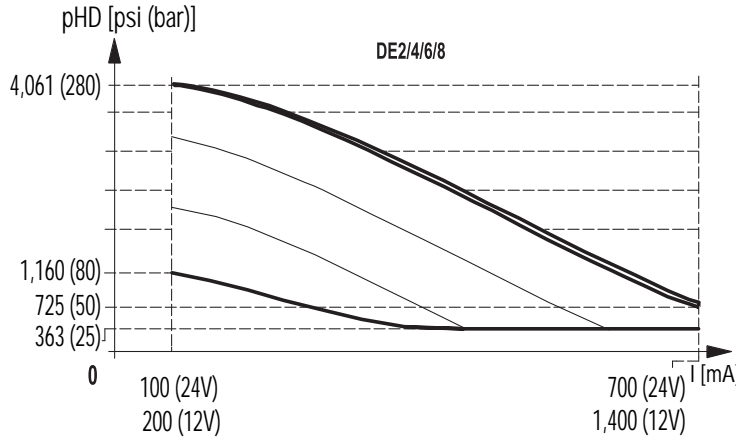

Dependence of standby pressure on high pressure (at I_{max})

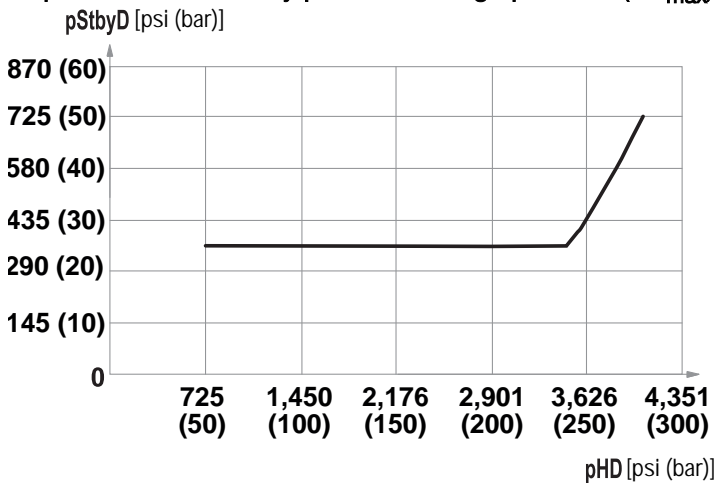

Additional technical data

Adjustment range, start of control	max	4,061 psi (280 bar)
	min	1,160 psi (80 bar)
Resulting end of control	max	725 psi (50 bar)
	min	363 psi (25 bar)
Standby pressure p_{StbyD}^* at $\Delta p = 290$ psi (20 bar)		363-725 psi (25-50 bar)

*) see diagram



Note

Technical data of proportional magnet, see section 3.4.

The DE- function is an electronic pressure control the pressure level of which can be continuously adjusted by a defined, variable magnetic field at the proportional magnet.

3 Actuation and control type

Axial piston pump
LH30VO 028 to 085

The pump is kept at $V_{g \max}$ by a spring. The high pressure is routed to a proportional pressure limiting valve by a pressure compensator (on a pressure control valve). When the opening pressure is reached, the pump's pressure control valve switches and the high pressure swings the pump in direction $V_{g \min}$, until the pressure level in the system is again below the proportional pressure limiting valve's set value.

In the function, for example, for fan drives, the axial piston unit swings to $V_{g \max}$ if there is no or only a faulty magnetic field at the proportional magnet.

If the magnetic field at the proportional magnet is increased to I_{\max} , the axial piston unit swings in the direction of $V_{g \min}$ and self-regulates to standby pressure (pStby).

3.3.7 VE- function, rising characteristic

Characteristic curve

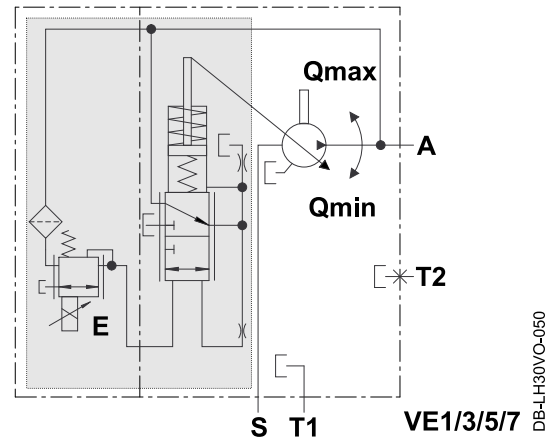
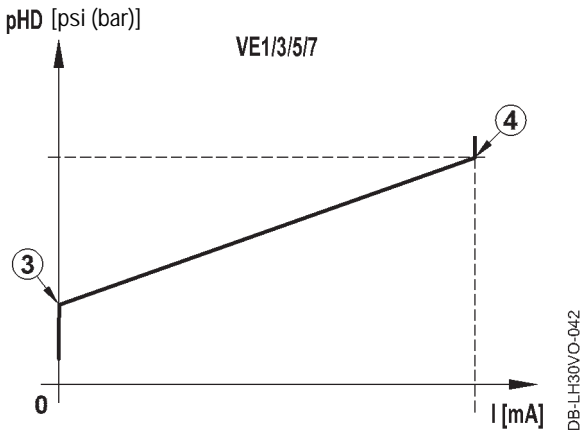

Additional technical data



Note

Technical data of pressure reduction valve, see section 3.4.3.

For the VE function, the axial piston unit's displacement volume V_g is continuously adjusted via a proportional magnet. As standard, the VE function is designed with a positive characteristic curve. (VE1/3/5/7)

In depressurized state, the cradle spring pushes the axial piston unit to the largest swivel angle $V_{g \max}$. This ensures pressure build-up. This is why the LH30VO does not need external auxiliary pressure.

At a pressure > 145 psi (10 bar) and a control current $I < 230$ mA (start of control 1), the axial piston unit swings to $V_{g \min}$ and can then be swung to an arbitrary angle with a rising control current $I (> 230$ mA, start of control 1). $V_{g \max}$ is reached at control current $I = 440$ mA (end of control 2).

The VE function can be used with a superordinate DA function; in other words, the control current-dependent VE function is only executed below the value set for pressure cut-off up to end of control 2.

3 Actuation and control type

Axial piston pump
LH30VO 028 to 085

3.3.8 VK- function, rising characteristic

Characteristic curve

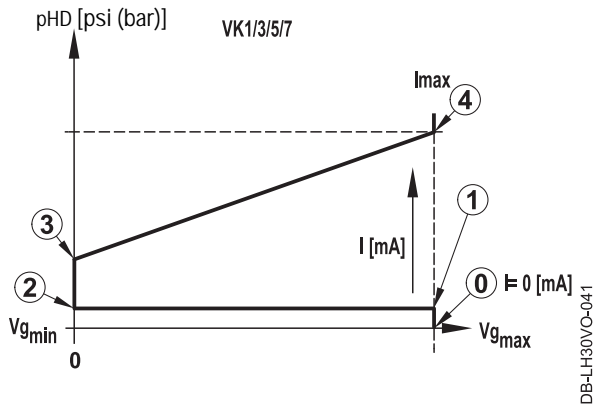

Additional technical data



Note

Technical data of pressure reduction valve, see section 3.4.3.

Based on the VE function (Nos. 2-4) with a positive characteristic curve (VE1/3/5/7), the VK function additionally features a jump function that allows the axial piston unit to swing to $V_{g_{max}}$ in the event of a missing or faulty actuation signal, for example, in the event of a cable break.

The proportional magnet must always be provided with a control current $I > 160$ mA (No. 2) to maintain the control function.

If the control current I drops below 160 mA due to an external influence (no or faulty actuation signal), the axial piston unit swings to $V_{g_{max}}$.

On restarting the machine, or after activating the jump function (dropping below control current $I < 160$ mA), the proportional magnet must be supplied with a control current $I_{max} = 440$ mA (No. 4) once only in order to be able to swing the axial piston unit to an arbitrary angle again.

3 Actuation and control type

Axial piston pump
LH30VO 028 to 085

3.3.9 VO- function

The functions of further control axes, for example, LS0DA- are overridden by the VO_ function.

Characteristic curve

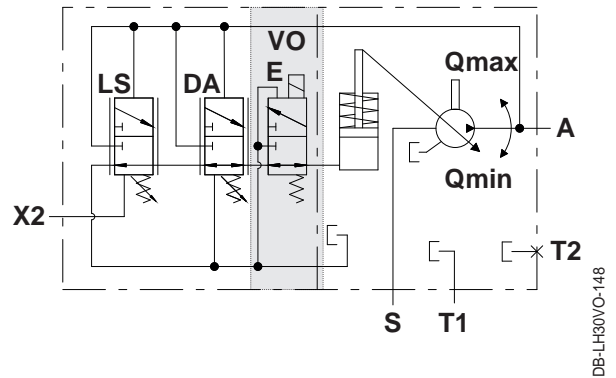
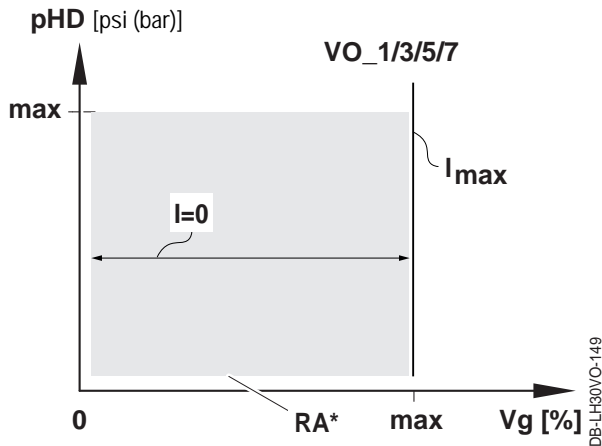

RA*) further control axes

The electrically actuated retarder function adjusts the axial piston unit to Vg max; this is done by energizing the switching magnets at connection E. Other control axes, e.g., LS0DA- are thereby disabled.

If the switching magnet at connection E is not energized (I= 0 mA), the other control axes are active.



Note

The VO_ function is only available as a combination control with other control axes; shown here using the LS0DA- as an example.

3 Actuation and control type

Axial piston pump
LH30VO 028 to 085

3.4 Electrical components

3.4.1 DE_1/3/5/7 (proportional magnet, rising characteristic)

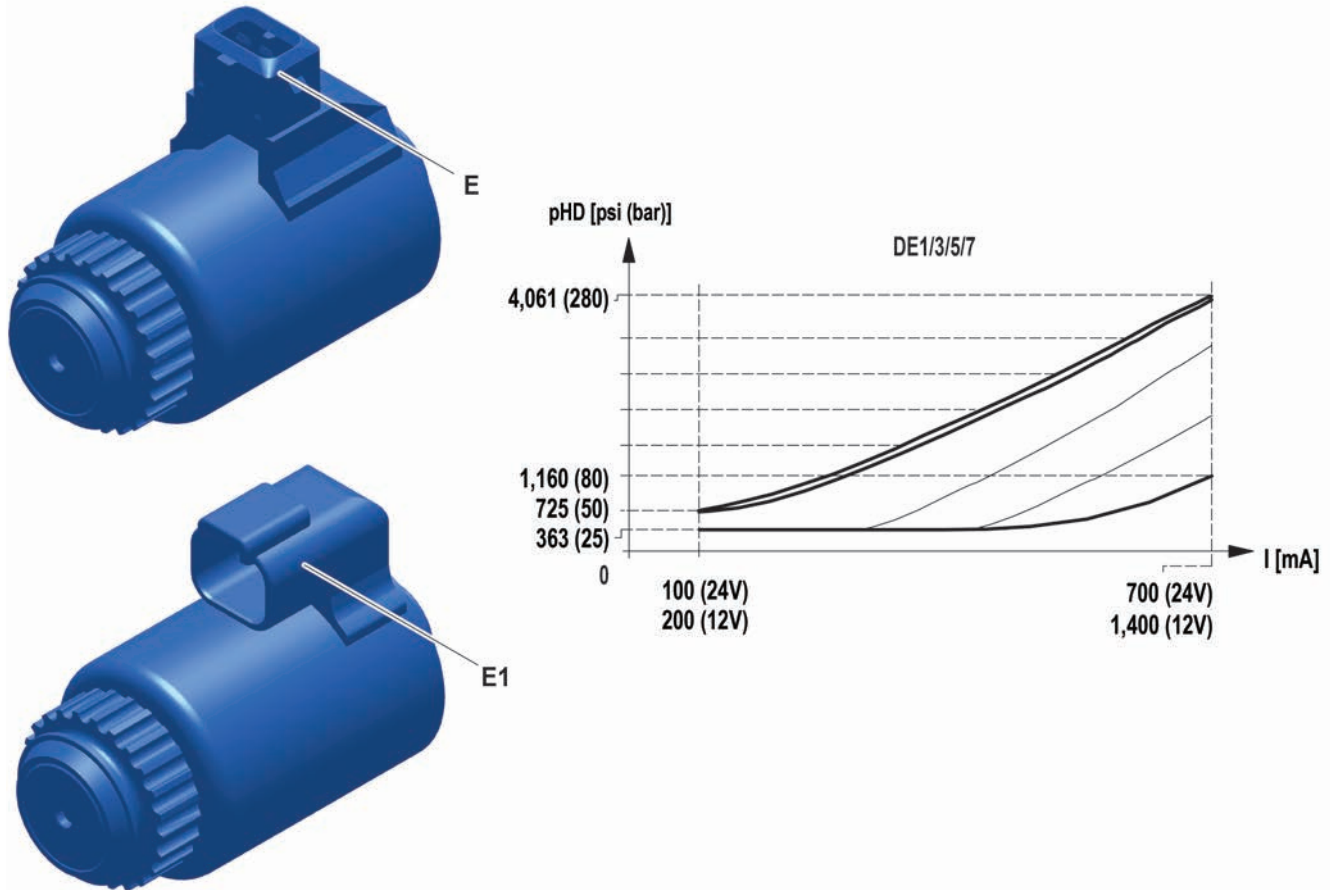

DB-LH30VO-111

Technical data of proportional magnet DE_	1/5	3/7
Connection E	AMP Junior Timer	
Connection E1	Deutsch DT04-2P	
Nominal voltage U	24 V	12 V
Current I_{max} .	700 mA	1,400 mA
Nominal resistance R	24.4 - 26.2 Ω	6.0 - 6.4 Ω
Power P	0.03 hp (18.7 W)	0.02 hp (18.3 W)
Dither frequency	100 - 200 Hz	
Minimal dither oscillation width within the control range	240 mA	120 mA
Duty cycle	100 %	
Degree of protection according to DIN VDE0470 when assembled and plugged in	max. IP 65	
Permissible ambient temperature	-4 °F to +176 °F (-20 °C to +80 °C)	

3 Actuation and control type

Axial piston pump
LH30VO 028 to 085

3.4.2 DE_2/4/6/8 (proportional magnet, falling characteristic)

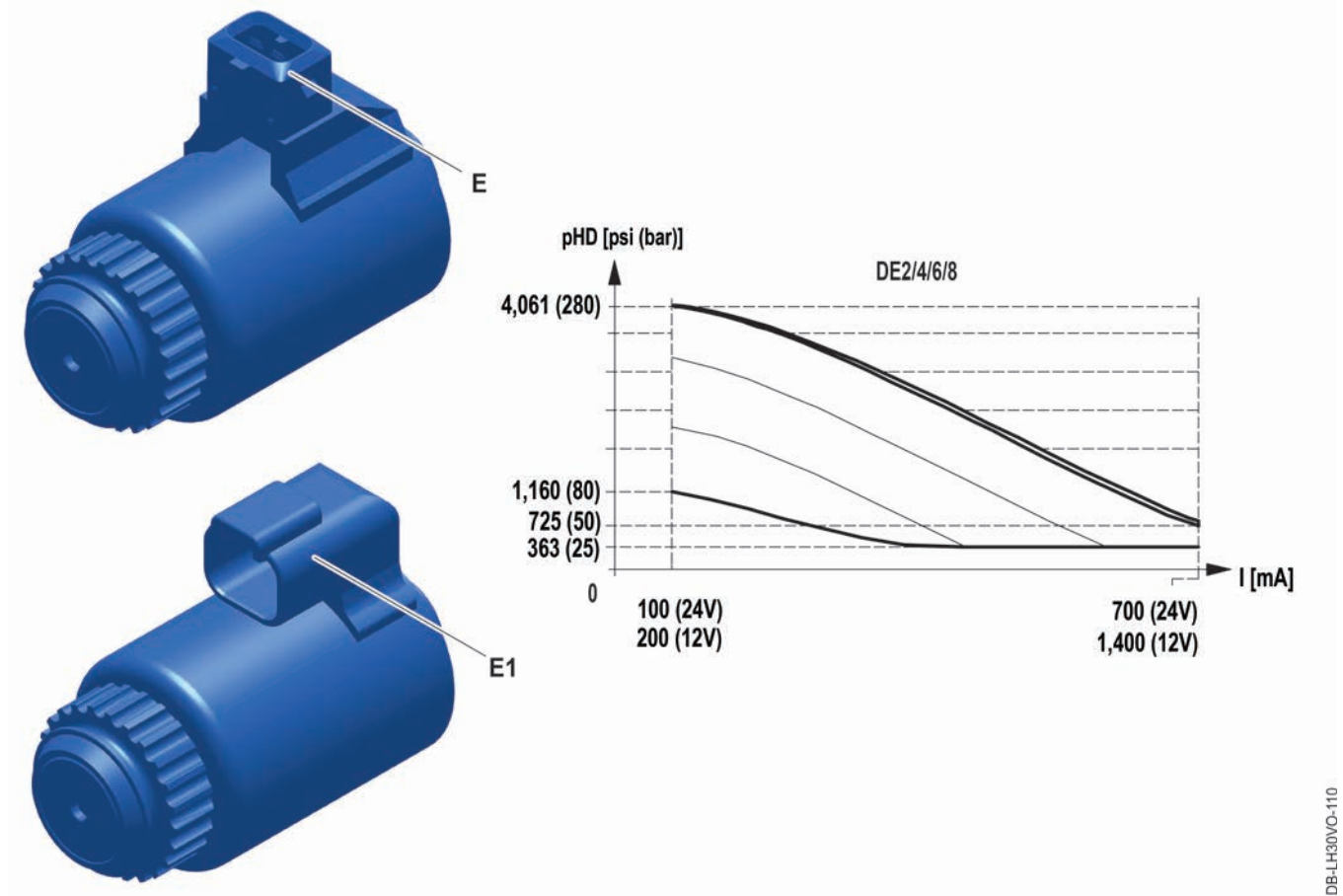

DB-LH30VO-110

Technical data of proportional magnet DE_	2/6	4/8
Connection E	AMP Junior Timer	
Connection E1	Deutsch DT04-2P	
Nominal voltage U	24 V	12 V
Current I _{max.}	700 mA	1,400 mA
Nominal resistance R	24.4 - 26.2 Ω	6.0 - 6.4 Ω
Power P	0.03 hp (18.7 W)	0.02 hp (18.3 W)
Dither frequency	100 - 200 Hz	
Minimal dither oscillation width within the control range	240 mA	120 mA
Duty cycle	100 %	
Degree of protection according to DIN VDE0470 when assembled and plugged in	max. IP 65	
Permissible ambient temperature	-4 °F to +176 °F (-20 °C to +80 °C)	

3 Actuation and control type

Axial piston pump
LH30VO 028 to 085

3.4.3 VE_ / VK_1/3/5/7 (pressure reduction valve)

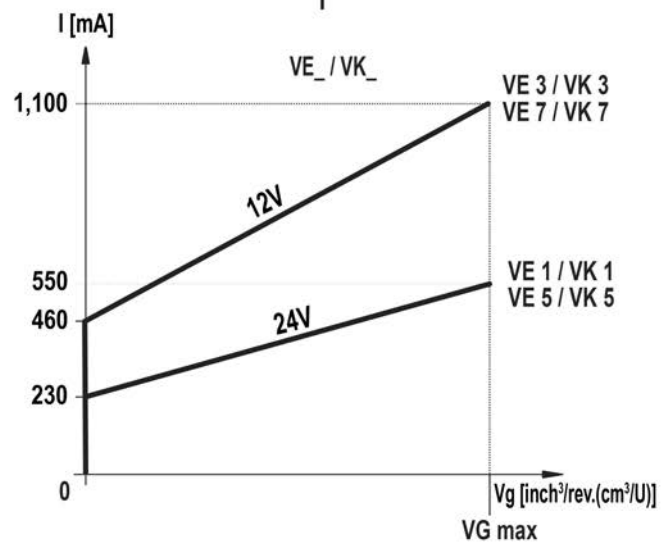
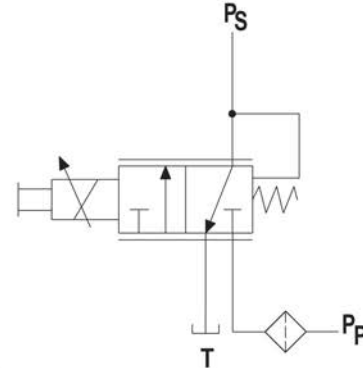
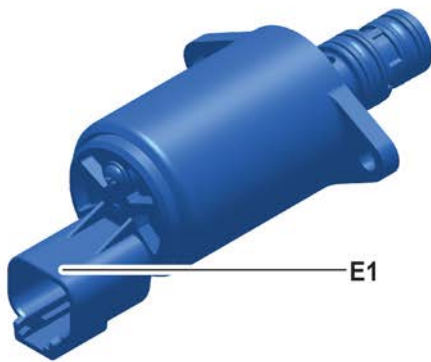
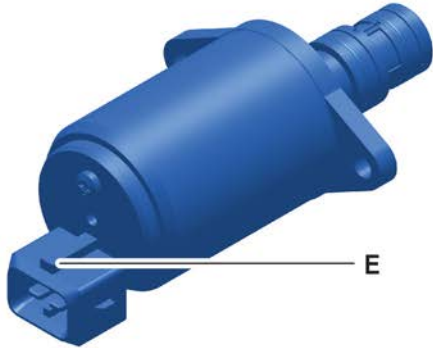

DBL-LH30VO-112

Technical data of pressure reduction valve VE_ / VK_	1/5	3/7
Connection E	AMP Junior Timer	
Connection E1	Deutsch DT04-2P	
Nominal voltage U	24 V	12 V
Current I _{max.}	750 mA	1,500 mA
Supply pressure p _{max.}	5,076 psi (350 bar)	
Nominal resistance R	22.0 Ω ± 6%	5.3 Ω ± 6%
Dither frequency	100 - 200 Hz	
Degree of protection according to DIN VDE0470/EN when assembled and plugged in	max. IP 67	
Permissible ambient temperature	-22 °F to +194 °F (-30 °C to +90 °C)	

3 Actuation and control type

Axial piston pump
LH30VO 028 to 085

3.4.4 VO_1/3/5/7 (switching magnet)

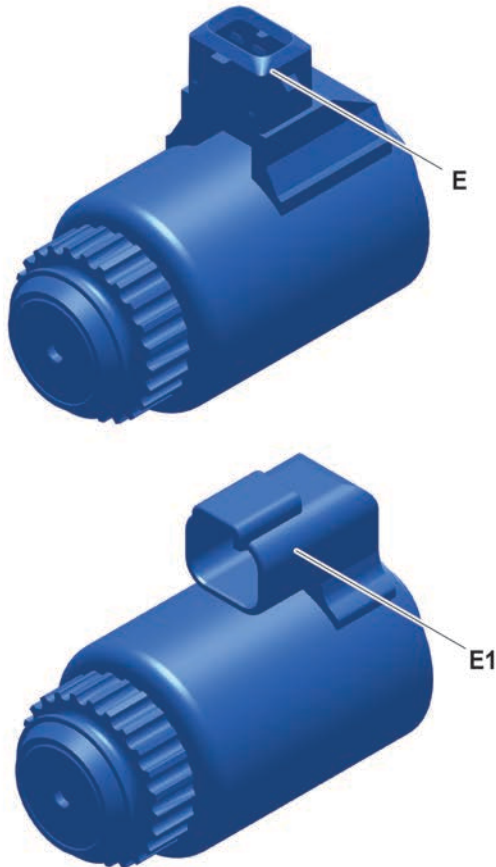

DB-LH30VO-140

Technical data of switching magnet VO_	1/5	3/7
Connection E	AMP Junior Timer	
Connection E1	Deutsch DT04-2P	
Nominal voltage U	24 V	12 V
Current I_{max}	700 mA	1,400 mA
Nominal resistance R	24.4 - 26.2 Ω	6.0 - 6.4 Ω
Power P	0.03 hp (18.7 W)	0.02 hp (18.3 W)
Dither frequency	100 - 200 Hz	
Minimal dither oscillation width within the control range	240 mA	120 mA
Duty cycle	100 %	
Degree of protection according to DIN VDE0470 when assembled and plugged in	max. IP 65	
Permissible ambient temperature	-4 °F to +176 °F (-20 °C to +80 °C)	

4 Installation conditions

Axial piston pump
LH30VO 028 to 085

4.1 General information on project planning

The installation variant provided in the device or system in combination with the installation position must be agreed on with Liebherr when designing the axial piston unit and must be approved by Liebherr.

Liebherr differentiates between three installation variants for axial piston units: A, B and C; and between six installation positions: 1-6.



Note

Liebherr recommends:
Installation variant: Under-tank installation A
Installation position: 2 driving shafts, horizontal, control at top



CAUTION

"Overheating" due to air pockets in the bearing area or rotary shaft lip seal in case of over-tank installation (installation variant B)!

Damage to the hydraulic product.

Ensure that the following conditions are met:

- The housing is completely filled with hydraulic fluid during commissioning and operation.
 - The housing is completely vented* after commissioning and during operation.
-

*) For installation positions 3 and 4, complete filling and venting is not possible without an additional leakage oil connection. In this case, the axial piston unit must be connected, filled and vented in installation position 2 prior to final positioning. It can then be rotated to installation position 3 or 4.

If installation position 3 and 4 is planned: Order leakage oil connection T4 as a special design.

["Type code" on page 3](#)



Note

For the over-tank installation B installation variant: a non-return valve must be provided in the leakage oil line. Maximum opening pressure of 7.25 psi (0.5 bar). Draining of the axial piston unit is prevented.

4.1.1 Leakage oil lines



Note

Route leakage oil line so that it is above the level of the axial piston unit.

4.1.2 Hydraulic fluid tank

The hydraulic fluid tank must be designed so that the hydraulic fluid cools sufficiently during circulation and that contamination from operation settles at the bottom of the tank.

Prevent formation of foam: Make sure that the lines in each installation variant/installation position open into the hydraulic fluid tank at least 7.87 inch (200 mm) below the minimum fluid level.

4 Installation conditions

Axial piston pump
LH30VO 028 to 085

4.2 Installation variants



Note

- Liebherr recommends: Under-tank installation A, which means that:
- There is hydraulic fluid at suction port S when not operated.
 - The housing cannot drain to the tank.

Under-tank installation "A": The axial piston unit is installed **below** the tank's minimum fluid level.
Over-tank installation "B": The axial piston unit is installed **above** the tank's minimum fluid level.

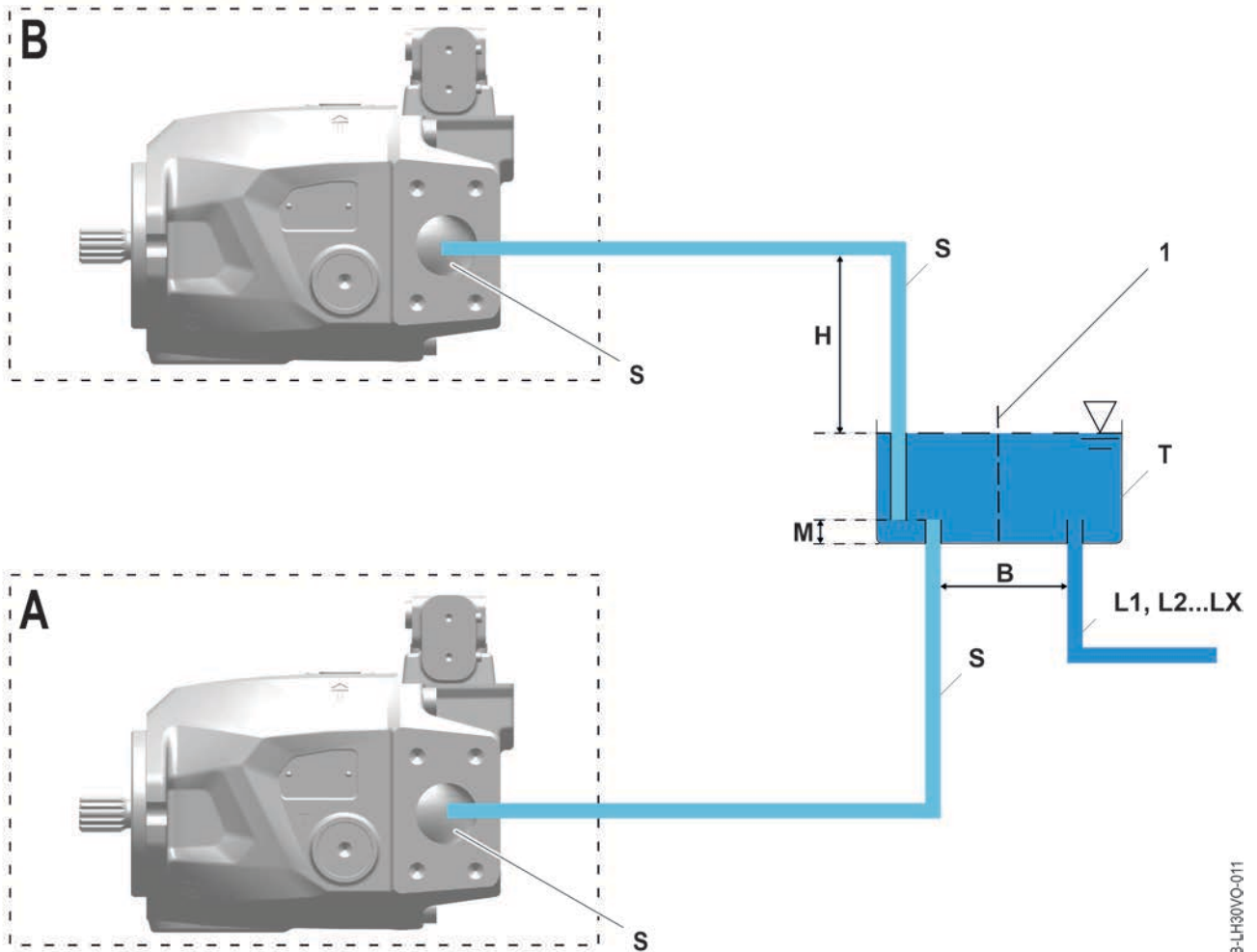

DB-LH30VO-011

1	Splash plate	To calm the hydraulic fluid in the tank
B	Clearance	Between suction port and leakage oil connection in the tank (the larger the better)
H	Maximum suction height (only for over-tank installation)	29.53 inch (750 mm)
L	Leakage oil connections	-
M	Minimum distance between line end and tank bottom	4.53 inch (115 mm)
S	Suction line connection	-
T	Tank	-

4 Installation conditions

Axial piston pump
LH30VO 028 to 085

Tank installation "C": The axial piston unit is installed **below** the minimum fluid level in the tank. This tank installation variant is not permitted for axial piston units with electric components (for example: electric proportional magnet).

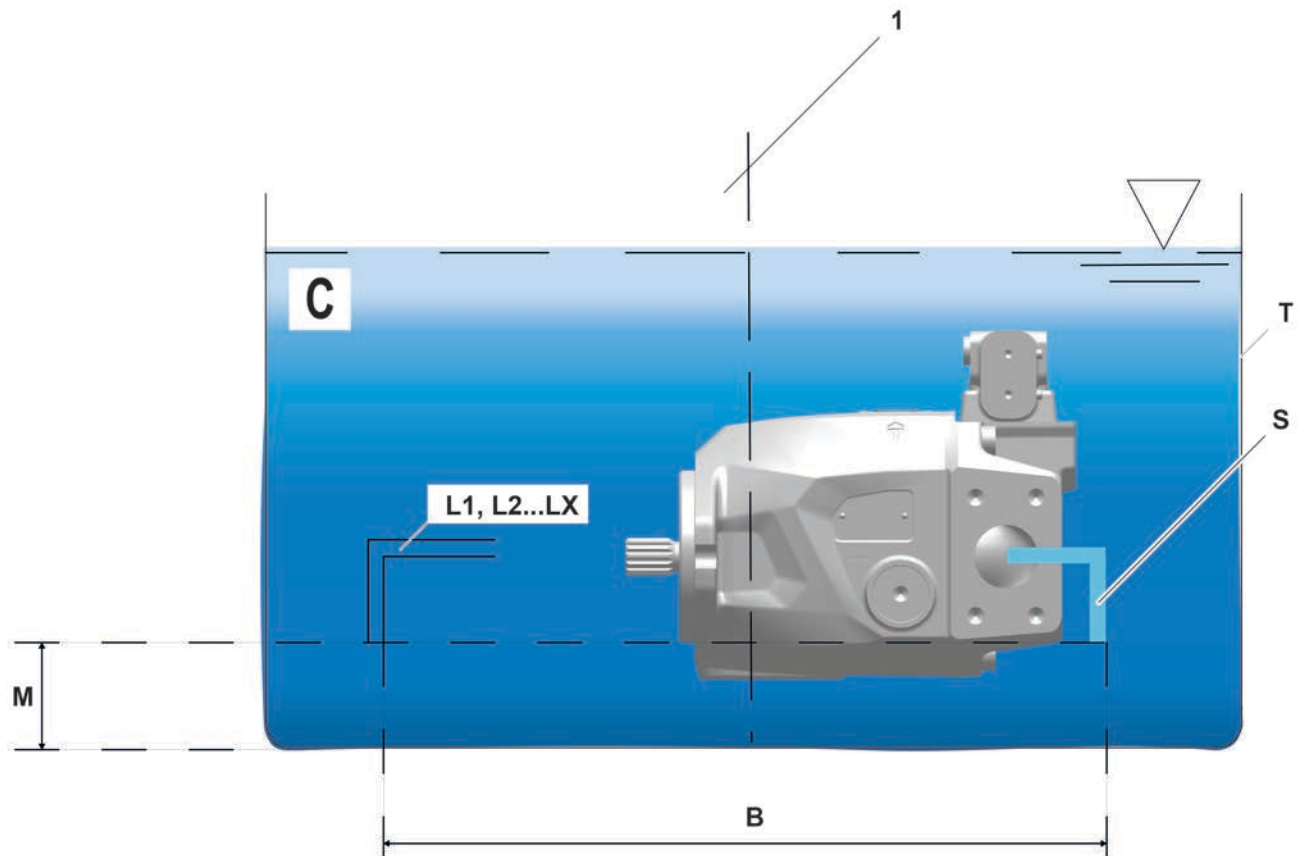

DB-LH30VO-012

1	Splash plate	To calm the hydraulic fluid in the tank
B	Clearance	Between suction port and leakage oil connection in the tank (the larger the better)
L	Leakage oil connections	-
M	Minimum distance between line end and tank bottom	4.53 inch (115 mm)
S	Suction line connection	-
T	Tank	-



Note

For the tank installation C installation variant, the hydraulic product must be ordered and used as a special design without primer. ["Type code" on page 3](#)

4 Installation conditions

Axial piston pump
LH30VO 028 to 085

4.3 Installation positions

There are six installation positions in each of the three installation variants.

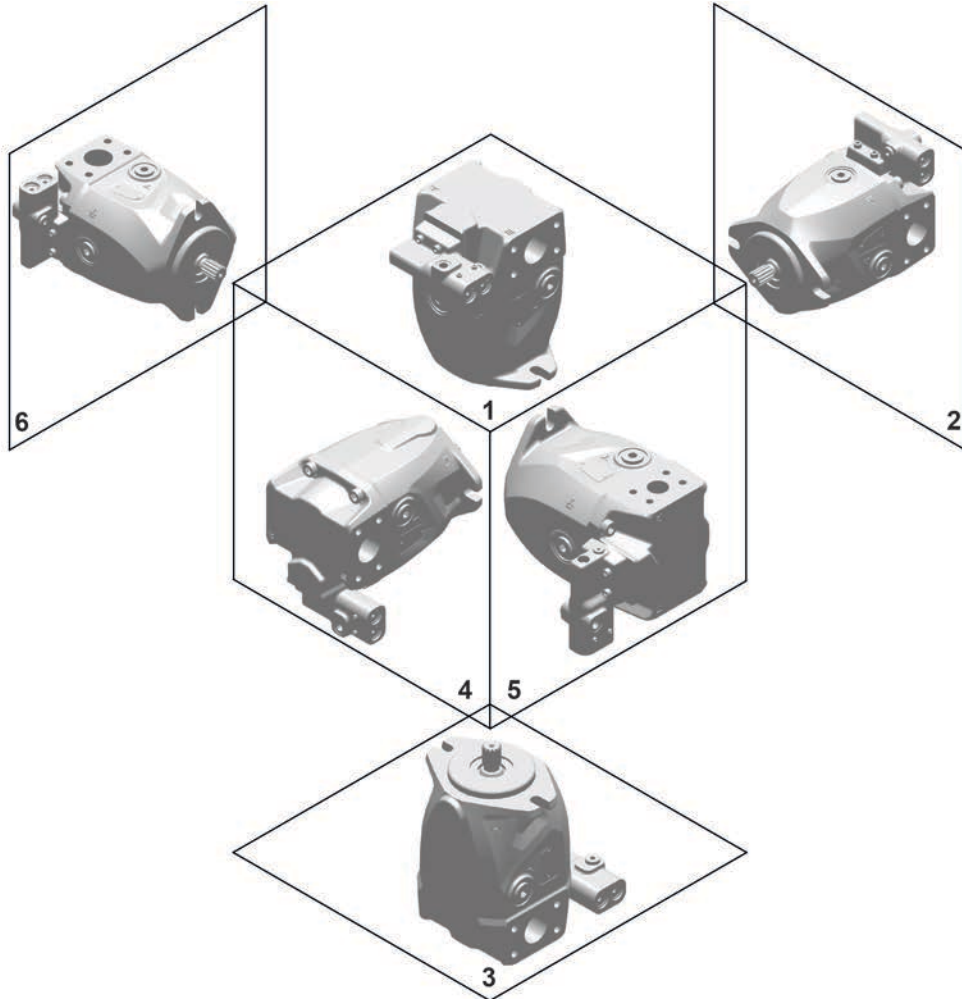

DB-LH30VO-105



Note

Installation positions 3 and 4 are critical for filling and venting. [For further information: see section 4.1.](#)

5 Dimensions

Axial piston pump
LH30VO 028 to 085

5.1 NS 028, main dimensions

5.1.1 Working connection, lateral, control type LS0DA- / LS1DA- / DF-DA-

1.	2.	3.	4.	5.	6.	7.	8.	9.	10.	11.	12.	13.	14.	15.	16.	17.	18.	19.	20.	21.	
L	H	3	0	V	O	028	/	LS0DA-	20	V	R	B2		B1	0	00	0000	000			

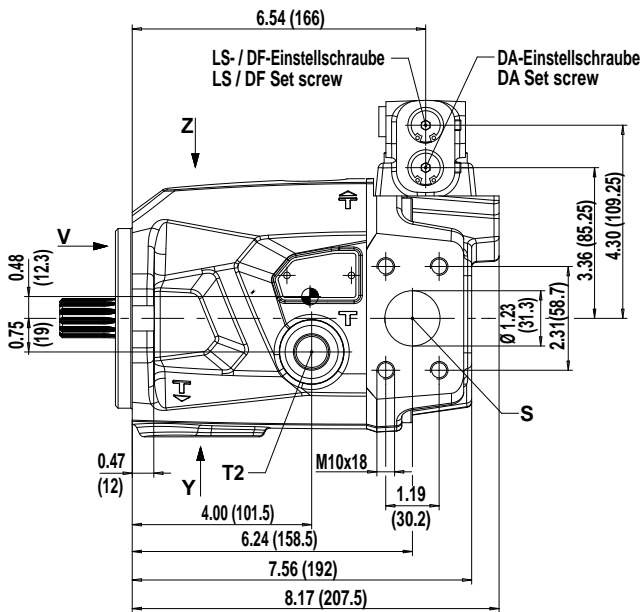

Stelle des Schwerpunktes
center of gravity location

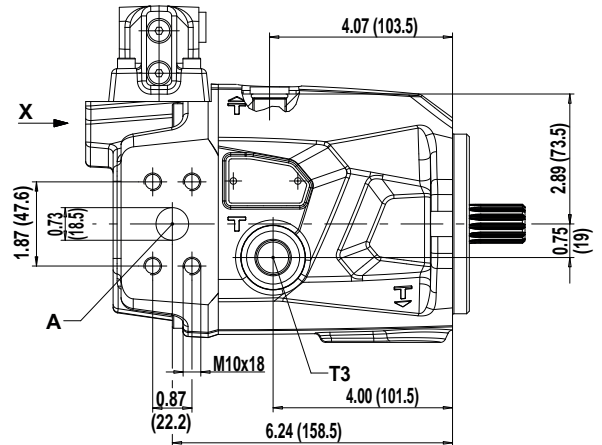

ANSICHT V
VIEW V

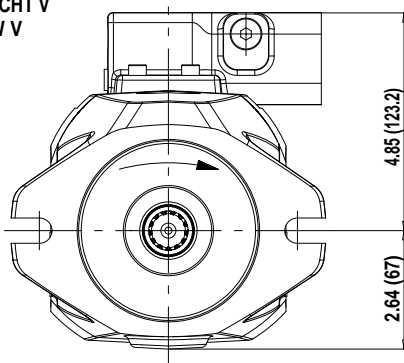

ANSICHT X
VIEW X

X2 (LS0DA-/LS1DA-)
X5 (DF-DA-)

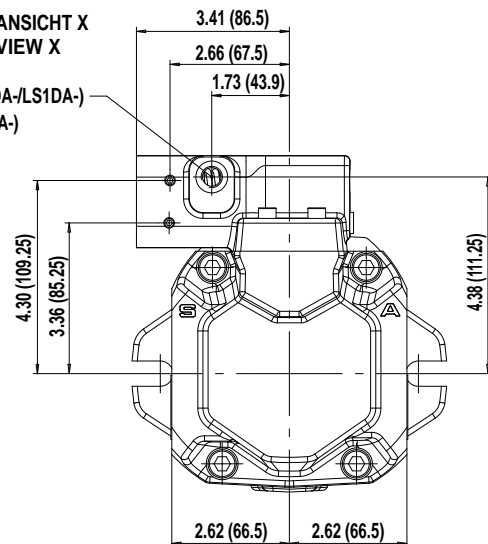

ANSICHT Y
VIEW Y

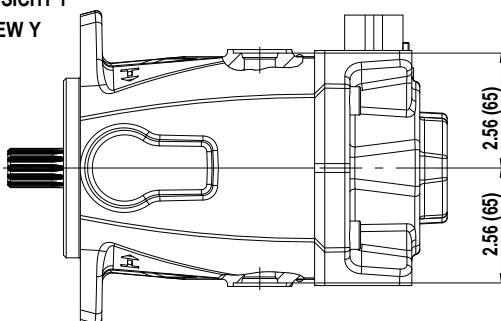

ANSICHT Z
VIEW Z

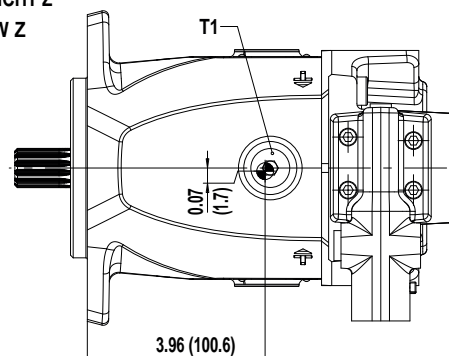

DB-LH30VO-118

5 Dimensions

Axial piston pump
LH30VO 028 to 085

A	Working connection ISO 6162-1 (SAE J518-1) - 3/4"
S	Suction port ISO 6162-1 (SAE J518-1) - 1 1/4"
T1, T2, T3	Leakage oil connections ISO 11926 - 3/4-16 UNF-2B

X2	LS0DA: LS pressure connection ISO 9974-1-M12x1.5 LS1DA: LS pressure connection ISO 9974-1-M12x1.5
X5	DF-DA-: DF control pressure connection for external pressure limiting valve, ISO 9974-1-M12x1.5
-	-



Note
Direction of rotation counterclockwise: Connecting plate and control arranged in mirror image.

5.1.2 NS 028, working connection, rear

1.	2.	3.	4.	5.	6.	7.	8.	9.	10.	11.	12.	13.	14.	15.	16.	17.	18.	19.	20.	21.	
L	H	3	0	V	O	028	/		20	V	R	B2		B3	0	00	0000	000			



Note
Dimensions not shown, see section 5.1.
Direction of rotation counterclockwise: Connecting plate and control arranged in mirror image.

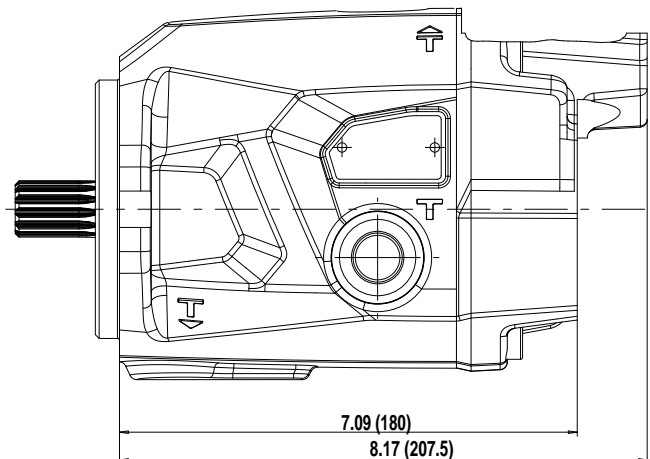
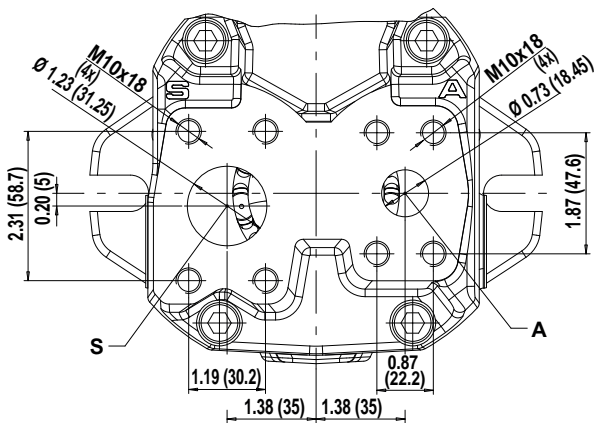

DB-LH30VO-120

5 Dimensions

Axial piston pump
LH30VO 028 to 085

5.1.3 NS 028, other control types

1.	2.	3.	4.	5.	6.	7.	8.	9.	10.	11.	12.	13.	14.	15.	16.	17.	18.	19.	20.	21.	
L	H	3	0	V	O	028	/	20	V	R				0	00	0000	000				



Note

Dimensions of control types LS0DA- / LS1DA- / DF-DA-, see section 5.1.

Direction of rotation counterclockwise: Connecting plate and control arranged in mirror image.

DA-

DB-LH30VO-127

-	-
-	-

LR-

DB-LH30VO-142

-	-
-	-

DE_

DB-LH30VO-124

E	1/2/3/4: Deutsch plug DT04-2P 2-pin 5/6/7/8: AMP plug Junior Timer 2-pin
-	-

LS0DE_ / LS1DE_

DB-LH30VO-126

E	1/2/3/4: Deutsch plug DT04-2P 2-pin 5/6/7/8: AMP plug Junior Timer 2-pin
X2	LS0DE_ : LS pressure connection ISO 9974-1-M12x1.5 LS1DE_ : LS pressure connection ISO 9974-1-M12x1.5

5 Dimensions

Axial piston pump
LH30VO 028 to 085

VE_ / VK_

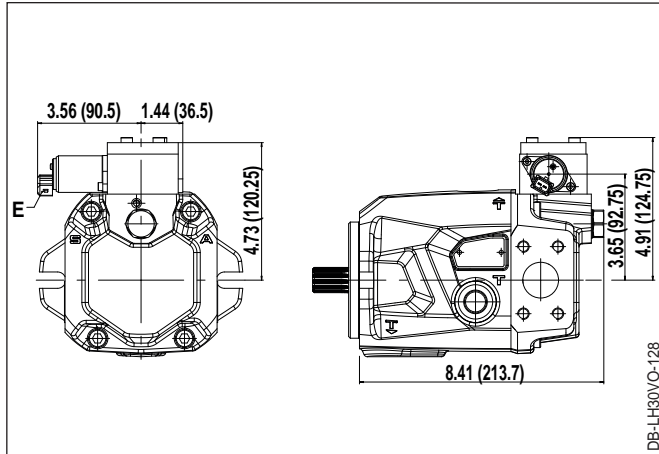

DB-LH30VO-128

E	1/3: Deutsch plug DT04-2P 2-pin 5/7: AMP plug Junior Timer 2-pin
-	-

LS0DA-VO_

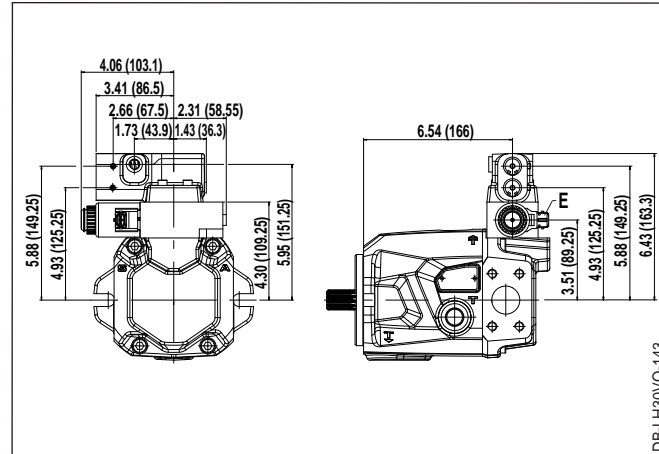

DB-LH30VO-143

E	1/3: Deutsch plug DT04-2P 2-pin 5/7: AMP plug Junior Timer 2-pin
-	-

5.2 NS 028, mounting flange

1.	2.	3.	4.	5.	6.	7.		8.	9.	10.	11.	12.	13.	14.	15.	16.	17.	18.	19.	20.	21.	
L	H	3	0	V	O	028	/		20	V		B2			0	00		000				

SAE B, (SAE J744)

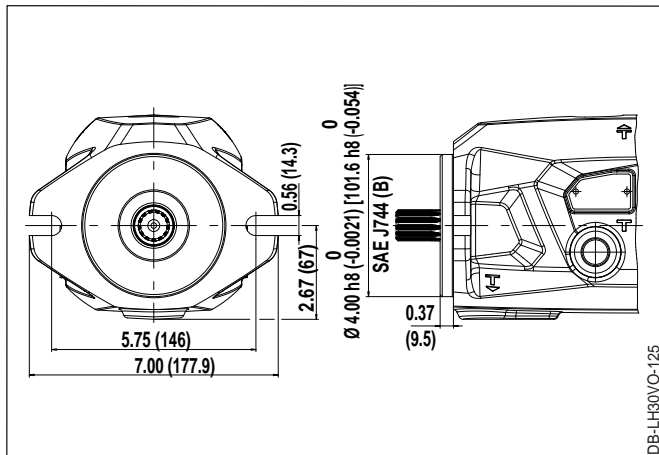

DB-LH30VO-125

B2

5 Dimensions

Axial piston pump
LH30VO 028 to 085

5.3 NS 028, shaft end

1.	2.	3.	4.	5.	6.	7.	8.	9.	10.	11.	12.	13.	14.	15.	16.	17.	18.	19.	20.	21.
L	H	3	0	V	O	028	/		20	V				0	00		000			

Splined shaft ANSI B92.1a-1976 7/8" 13T, with undercut

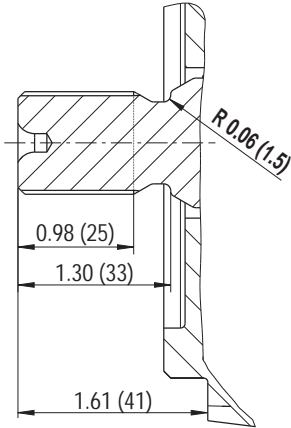

DB-LH30VO-072

A1

Splined shaft ANSI B92.1a-1976 7/8" 13T, without undercut

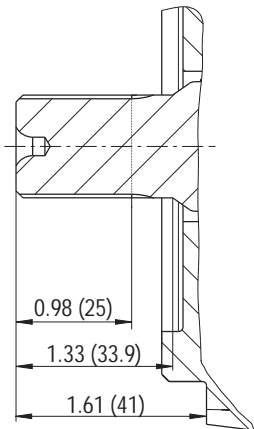

DB-LH30VO-071

A2

5 Dimensions

Axial piston pump
LH30VO 028 to 085

5.4 NS 045, main dimensions

5.4.1 Working connection, lateral, control type LS0DA- / LS1DA- / DF-DA-

1.	2.	3.	4.	5.	6.	7.	8.	9.	10.	11.	12.	13.	14.	15.	16.	17.	18.	19.	20.	21.	
L	H	3	0	V	O	045	/	LS0DA-	20	V	R	B2		B1	0	00	0000	000			

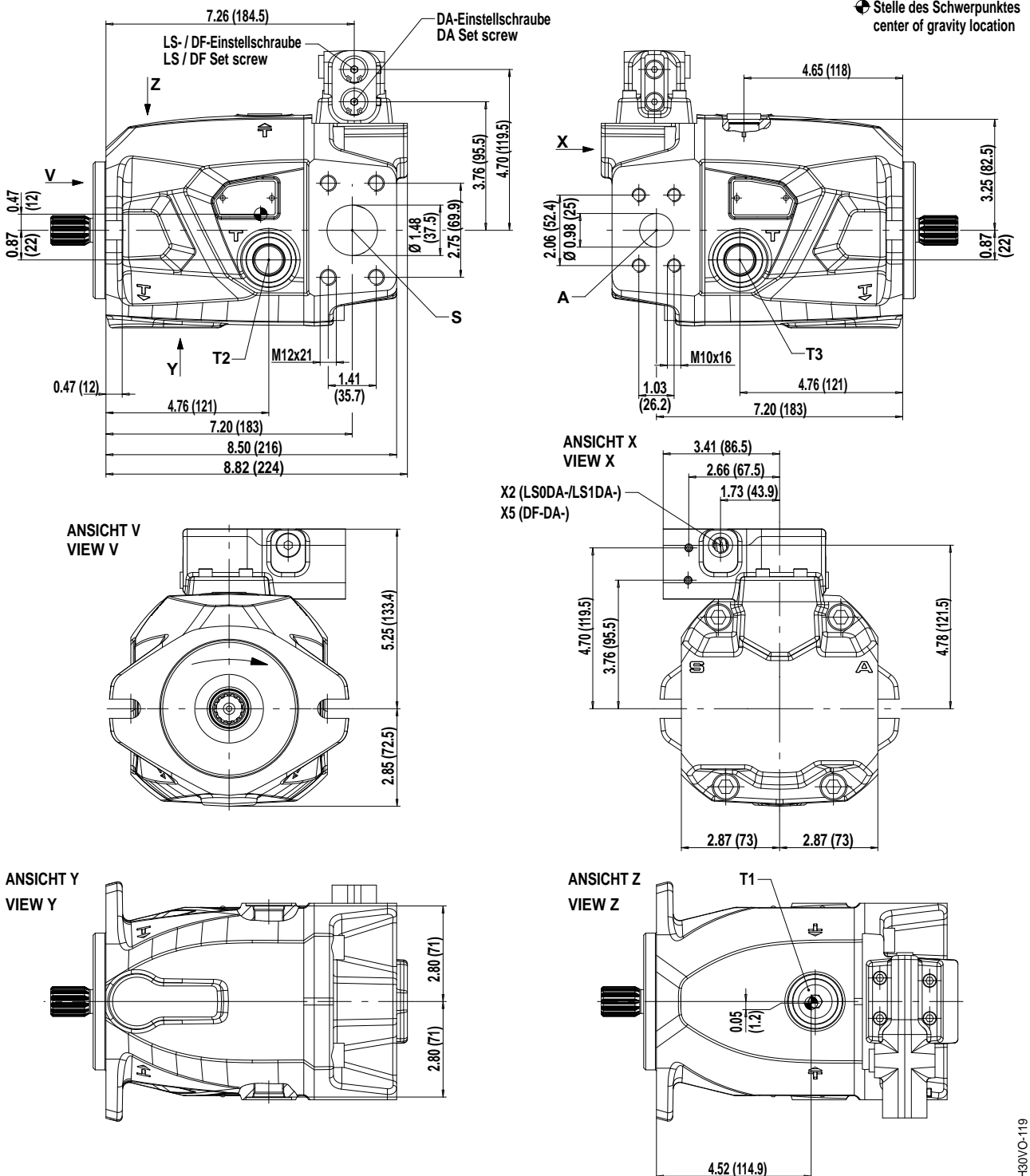

DB-LH30VO-119

5 Dimensions

Axial piston pump
LH30VO 028 to 085

A	Working connection ISO 6162-1/-2 (SAE J518-1/-2) - 1"	X2	LS0DA: LS pressure connection ISO 9974-1-M12x1.5 LS1DA: LS pressure connection ISO 9974-1-M12x1.5
S	Suction port ISO 6162-1/-2 (SAE J518-1/-2) - 1 1/2"	X5	DF-DA-: DF control pressure connection for external pressure limiting valve, ISO 9974-1-M12x1.5
T1, T2, T3	Leakage oil connections ISO 11926 - 7/8-14 UNF-2B	-	-



Note
Direction of rotation counterclockwise: Connecting plate and control arranged in mirror image.

5.4.2 NS 045, working connection, rear

1.	2.	3.	4.	5.	6.	7.	8.	9.	10.	11.	12.	13.	14.	15.	16.	17.	18.	19.	20.	21.	
L	H	3	0	V	O	045	/	20	V	R			B3	0	00	0000	000				



Note
Dimensions not shown, see section 5.1.
Direction of rotation counterclockwise: Connecting plate and control arranged in mirror image.

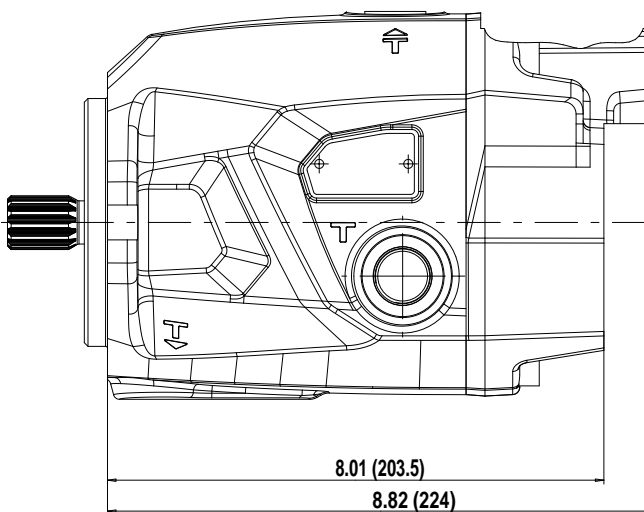
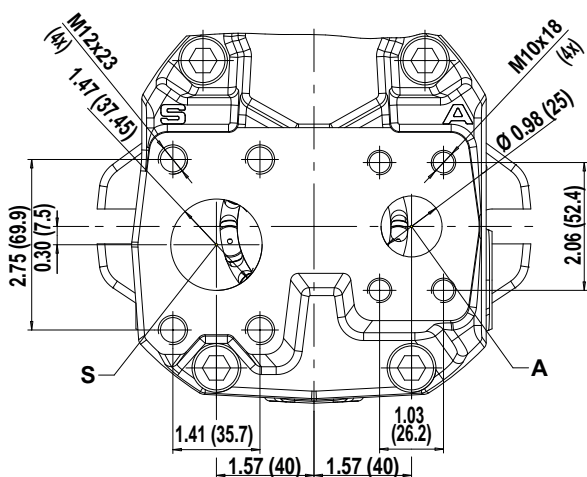

DB-LH30VO-122

5 Dimensions

Axial piston pump
LH30VO 028 to 085

5.4.3 NS 045, other control types

1.	2.	3.	4.	5.	6.	7.		8	9.	10.	11.	12.	13.	14	15	16	17	18	19	20	21	
L	H	3	0	V	O	045	/		20	V	R			B1	0	00	0000	000				



Note

Dimensions of control types LS0DA- / LS1DA- / DF-DA-, see section 5.1.

Direction of rotation counterclockwise: Connecting plate and control arranged in mirror image.

DA-

-	-
-	-

LR-

-	-
-	-

DE_

E	1/2/3/4: Deutsch plug DT04-2P 2-pin 5/6/7/8: AMP plug Junior Timer 2-pin
-	-

LS0DE_ / LS1DE_

E	1/2/3/4: Deutsch plug DT04-2P 2-pin 5/6/7/8: AMP plug Junior Timer 2-pin
X2	LS0DE : LS pressure connection ISO 9974-1-M12x1.5 LS1DE : LS pressure connection ISO 9974-1-M12x1.5

5 Dimensions

Axial piston pump
LH30VO 028 to 085

VE_ / VK_

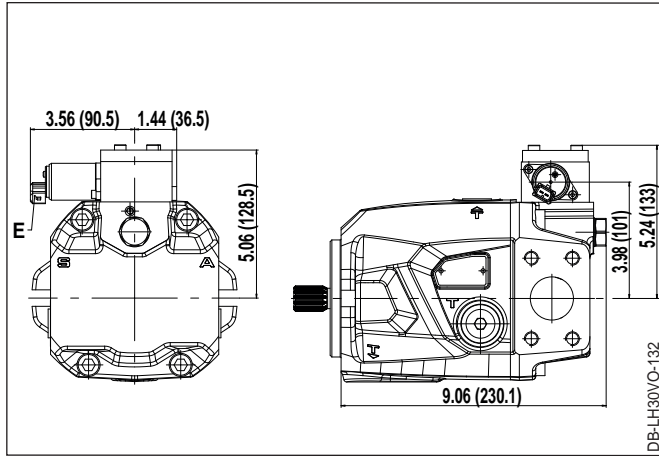

E	1/3: Deutsch plug DT04-2P 2-pin 5/7: AMP plug Junior Timer 2-pin
-	-

LS0DA-VO_

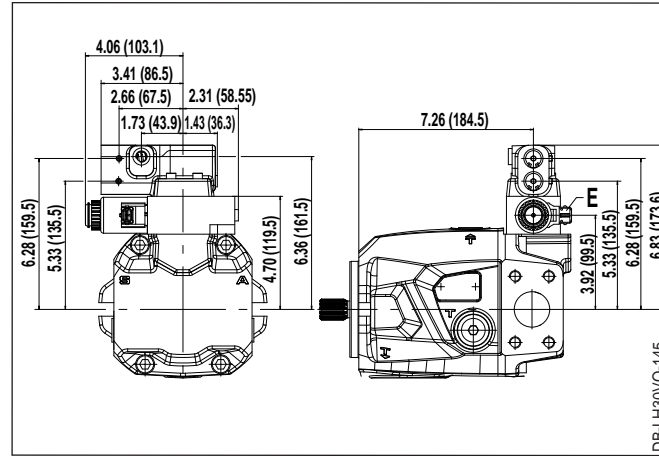

E	1/3: Deutsch plug DT04-2P 2-pin 5/7: AMP plug Junior Timer 2-pin
-	-

5.5 NS 045, mounting flange

1.	2.	3.	4.	5.	6.	7.	8.	9.	10.	11.	12.	13.	14.	15.	16.	17.	18.	19.	20.	21.
L	H	3	0	V	O	045	/	20	V		B2			0	00		000			

SAE B, (SAE J744)

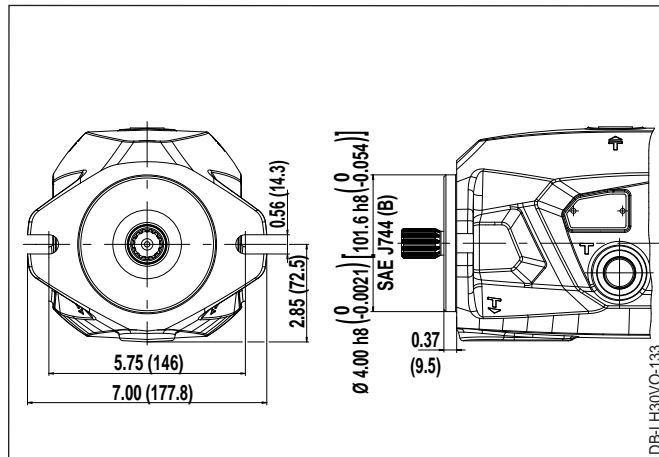

B2

5 Dimensions

Axial piston pump
LH30VO 028 to 085

5.6 NS 045, shaft end

1.	2.	3.	4.	5.	6.	7.	8.	9.	10.	11.	12.	13.	14.	15.	16.	17.	18.	19.	20.	21.
L	H	3	0	V	O	045	/		20	V				0	00		000			

Splined shaft ANSI B92.1a-1976 7/8" 13T, with undercut

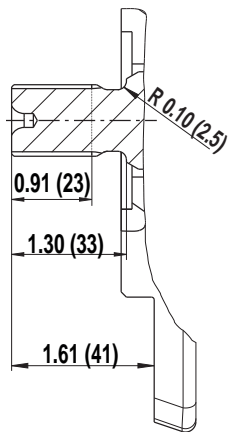

DB-LH30VO-073

A1

Splined shaft ANSI B92.1a-1976 7/8" 13T, without undercut

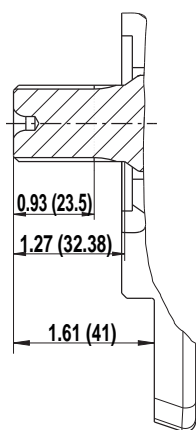

DB-LH30VO-074

A2

Splined shaft ANSI B92.1a-1976 1" 15T, with undercut

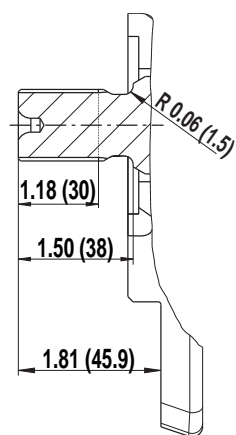

DB-LH30VO-075

A3

5 Dimensions

Axial piston pump
LH30VO 028 to 085

Splined shaft ANSI B92.1a-1976 1" 15T, without undercut

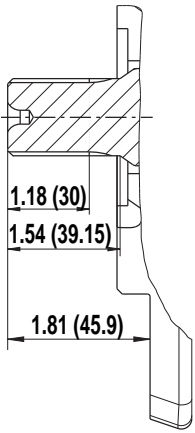

DB-LH30VO-076

A4

5 Dimensions

Axial piston pump
LH30VO 028 to 085

5.7 NS 085 main dimensions

5.7.1 Working connection, lateral, control type LS0DA- / LS1DA- / DF-DA-

1.	2.	3.	4.	5.	6.	7.	8.	9.	10.	11.	12.	13.	14.	15.	16.	17.	18.	19.	20.	21.	
L	H	3	0	V	O	085	/	LS0DA-	20	V	R	C6		A1	0	00	0000	000			

☛ Stelle des Schwerpunktes
center of gravity location

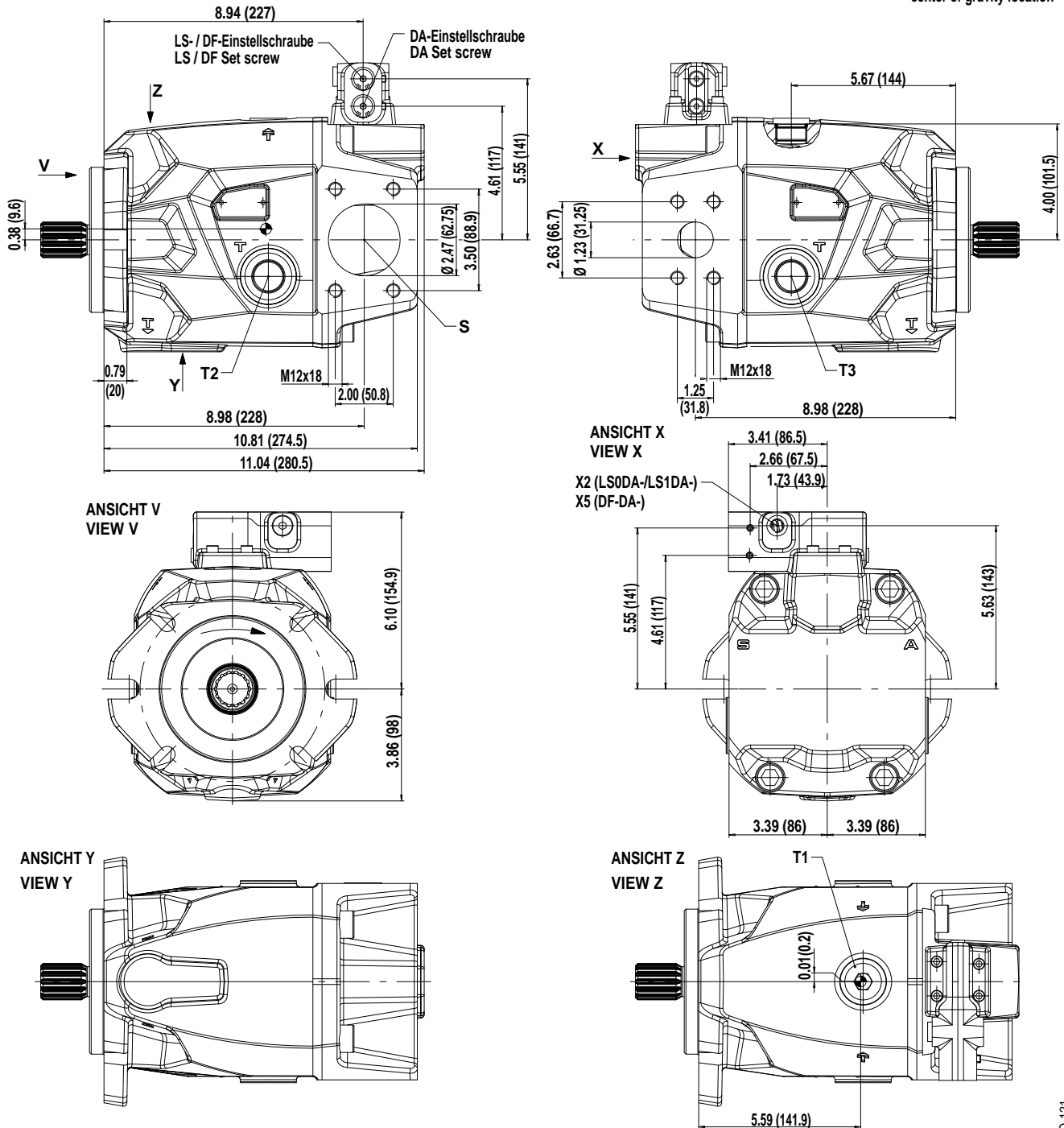

DB-LH30VO-121

5 Dimensions

Axial piston pump
LH30VO 028 to 085

A	Working connection ISO 6162-2 (SAE J518-2) - 1 1/4"	X2	LS0DA: LS pressure connection ISO 9974-1-M12x1.5 LS1DA: LS pressure connection ISO 9974-1-M12x1.5
S	Suction port ISO 6162-2 (SAE J518-2) - 2 1/2"	X5	DF-DA-: DF control pressure connection for external pressure limiting valve, ISO 9974-1-M12x1.5
T1, T2, T3	Leakage oil connections ISO 11926 - 1 1/16-12 UNF-2B	-	-



Note
Direction of rotation counterclockwise: Connecting plate and control arranged in mirror image.

5.7.2 NS 085, working connection, rear

1.	2.	3.	4.	5.	6.	7.	8.	9.	10.	11.	12.	13.	14.	15.	16.	17.	18.	19.	20.	21.
L	H	3	0	V	O	085	/	20	V	R	C6		A3	0	00	0000	000			



Note
Dimensions not shown, see section 5.1.
Direction of rotation counterclockwise: Connecting plate and control arranged in mirror image.

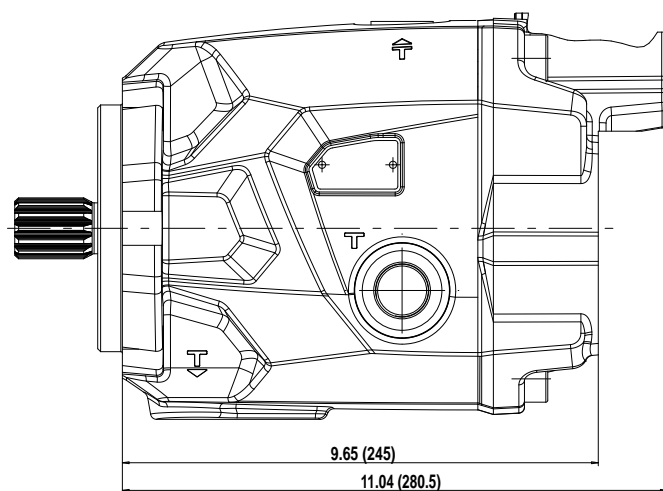
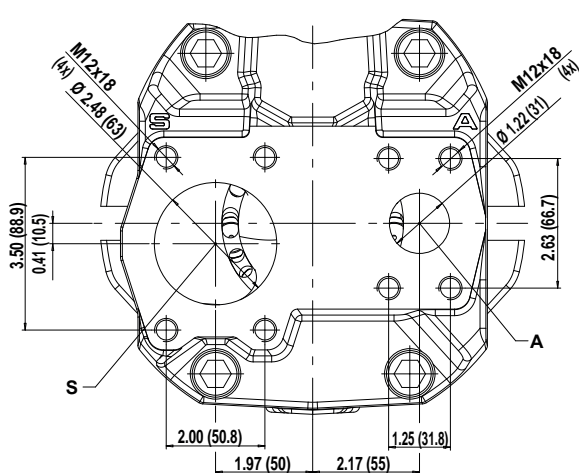

DB-LH30VO-123

5 Dimensions

Axial piston pump
LH30VO 028 to 085

5.7.3 NS 085, other control types

1.	2.	3.	4.	5.	6.	7.		8	9.	10.	11.	12.	13.	14	15	16	17	18	19	20	21
L	H	3	0	V	O	085	/		20	V	R			A1	0	00	0000	000			



Note

Dimensions of control types LS0DA- / LS1DA- / DF-DA-, see section 5.1.

Direction of rotation counterclockwise: Connecting plate and control arranged in mirror image.

DA-

DB-LH30VO-136

-	-
-	-

LR-

DB-LH30VO-146

-	-
-	-

DE_

DB-LH30VO-134

E	1/2/3/4: Deutsch plug DT04-2P 2-pin 5/6/7/8: AMP plug Junior Timer 2-pin
-	-

LS0DE_ / LS1DE_

DB-LH30VO-135

E	1/2/3/4: Deutsch plug DT04-2P 2-pin 5/6/7/8: AMP plug Junior Timer 2-pin
X2	LS0DE_ : LS pressure connection ISO 9974-1-M12x1.5 LS1DE_ : LS pressure connection ISO 9974-1-M12x1.5

5 Dimensions

Axial piston pump
LH30VO 028 to 085



Note

Direction of rotation clockwise: Connecting plate and control arranged in mirror image.

VE_ / VK_

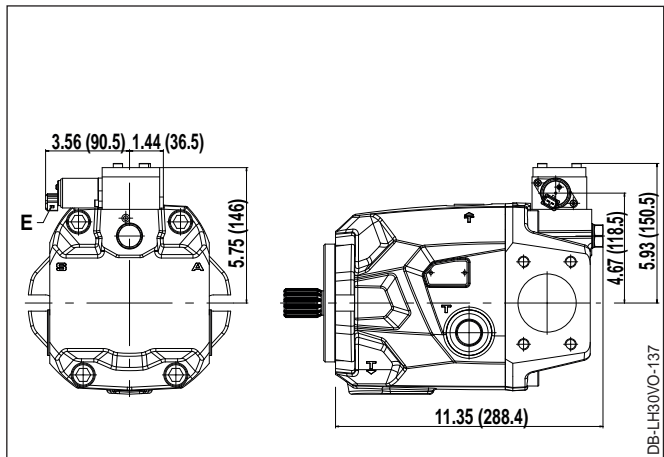

E	1/3: Deutsch plug DT04-2P 2-pin 5/7: AMP plug Junior Timer 2-pin
-	-

LS0DA-VO_

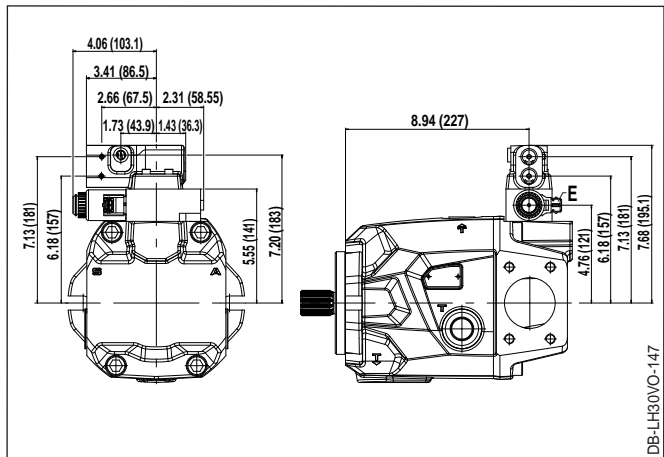

E	1/3: Deutsch plug DT04-2P 2-pin 5/7: AMP plug Junior Timer 2-pin
-	-

5.8 NS 085, mounting flange

1.	2.	3.	4.	5.	6.	7.	8.	9.	10.	11.	12.	13.	14.	15.	16.	17.	18.	19.	20.	21.
L	H	3	0	V	O	085	/	20	V		C6			0	00		000			

Similar to SAE C, (SAE J744), 2+4-hole fastening

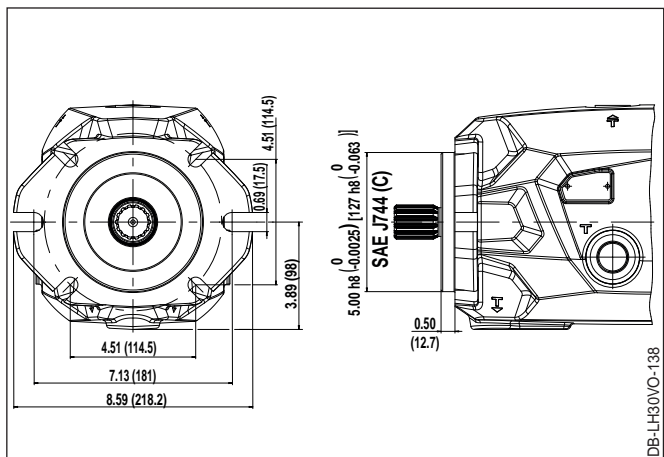

C6

5 Dimensions

Axial piston pump
LH30VO 028 to 085

5.9 NS 085, shaft end

1.	2.	3.	4.	5.	6.	7.	8.	9.	10.	11.	12.	13.	14.	15.	16.	17.	18.	19.	20.	21.
L	H	3	0	V	O	085	/		20	V				0	00		000			

Splined shaft ANSI B92.1a-1976 1 1/4" 14T, with undercut

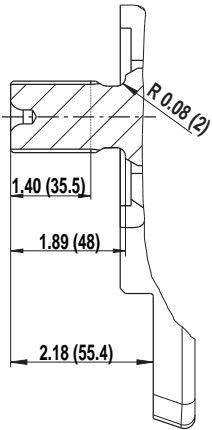

DB-LH30VO-078

A5

Splined shaft ANSI B92.1a-1976 1 1/4" 14T, without undercut

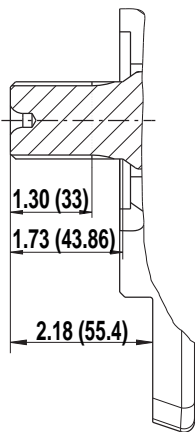

DB-LH30VO-077

A6

Splined shaft ANSI B92.1a-1976 1 1/2" 17T, without undercut

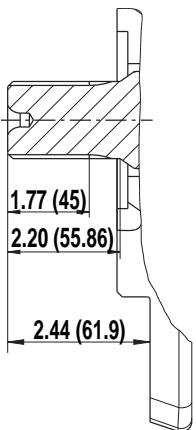

DB-LH30VO-079

A0

5 Dimensions

Axial piston pump
LH30VO 028 to 085

5.10 Through-drive

1.	2.	3.	4.	5.	6.	7.	8.	9.	10.	11.	12.	13.	14.	15.	16.	17.	18.	19.	20.	21.
L	H	3	0	V	O	/		20	V					0	00		000			

5.10.1 Axial piston unit without through-drive



Note

For dimensions for axial piston unit without through-drive, see main dimensions.

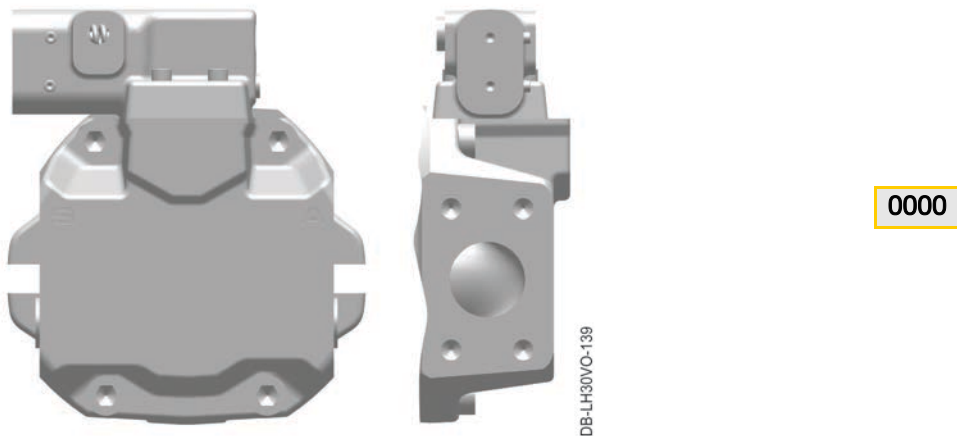

5.10.2 Axial piston unit with preparation for adapter mounting kit



Note

Preparation for adapter mounting kit, sealed with cover.
To use the through-drive, the selected adapter mounting kit including coupling ferrule (see installation drawing) must be ordered separately; the cover must be removed and the adapter mounting kit fitted.

NS	L	L*
028	8.05 (204.5)	8.41 (213.7)
045	9.00 (228.5)	9.06 (230.1)
085	11.30 (287)	11.35 (288.4)

L) Up to mounting flange
L*) Total length of axial piston unit with control type VE_/VK_ and LR- (see note).

5 Dimensions

Axial piston pump LH30VO 028 to 085



Note

NS 028: Total length of axial piston unit with control type VE_/VK_ and LR-, see section 5.1.3.
 NS 045: Total length of axial piston unit with control type VE_/VK_ and LR-, see section 5.4.3.
 NS 085: Total length of axial piston unit with control type VE_/VK_ and LR-, see section 5.7.3.

5.10.3 Axial piston unit with through-drive SAE A



Note

O-ring for sealing of axial piston unit 2 is included in the scope of delivery.
 NS 028 / 045: The following applies to control type VE_/VK_ and LR-; total length up to mounting flange L + 0.51 inch (13 mm).

Shaft gearing: 5/8 in 9T 16/32DP

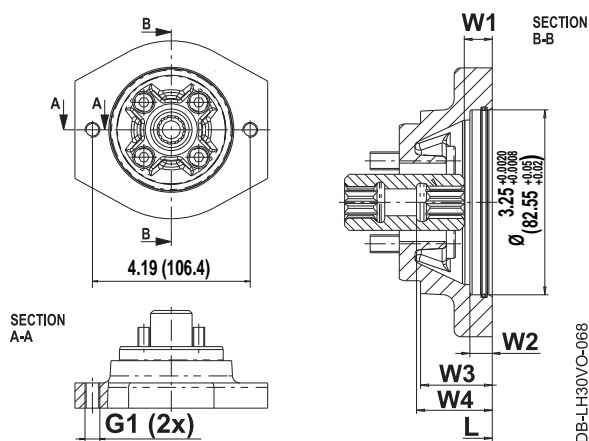

A11D 2-hole

NS	W1	W2	W3	W4	L	G1 (2-hole)
028	0.39 (9.9)	0.394 (10)	1.26 (32)	1.33 (33.8)	8.66 (220)	M10x1.5; 17 deep
045	0.57 (14.5)	0.394 (10)	1.26 (32)	1.41 (35.8)	9.61 (244)	M10x1.5; 17 deep
085	0.53 (13.4)	0.394 (10)	0.77 (19.5)	1.34 (34)	11.42 (290)	M10x1.5; 19.5 deep

L*) Up to mounting flange

5.10.4 Axial piston unit with through-drive SAE A-B



Note

O-ring for sealing of axial piston unit 2 is included in the scope of delivery.
 NS 028 / 045: The following applies to control type VE_/VK_ and LR-; total length up to mounting flange L + 0.51 inch (13 mm).

Shaft gearing: 3/4 in 11T 16/32DP

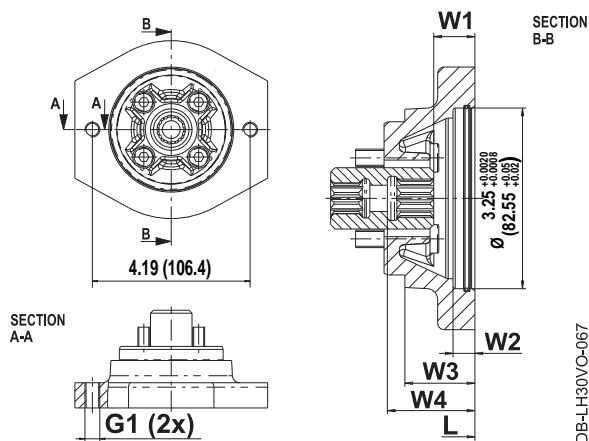

A21D 2-hole

NS	W1	W2	W3	W4	L	G1 (2-hole)
028	0.74 (18.8)	0.394 (10)	1.26 (32)	1.57 (40)	8.66 (220)	M10x1.5; 17 deep
045	0.82 (20.9)	0.394 (10)	1.26 (32)	1.66 (42.1)	9.61 (244)	M10x1.5; 17 deep
085	0.93 (23.6)	0.394 (10)	0.77 (19.5)	1.57 (40)	11.42 (290)	M10x1.5; 19.5 deep

L*) Up to mounting flange

5 Dimensions

Axial piston pump
LH30VO 028 to 085

5.10.5 Axial piston unit with through-drive SAE B



Note

O-ring for sealing of axial piston unit 2 is included in the scope of delivery.
NS 028 / 045: The following applies to control type VE_/VK_ and LR-; total length up to mounting flange L + 0.51 inch (13 mm).

Shaft gearing: 7/8 in 13T 16/32DP

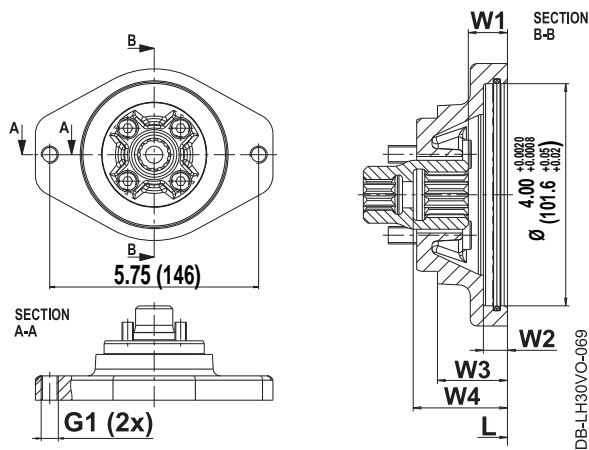

B11D 2-hole

NS	W1	W2	W3	W4	L	G1 (2-hole)
028	0.70 (17.8)	0.43 (11)	1.26 (32)	1.70 (43.1)	8.66 (220)	M12x1.5; 17 deep
045	0.85 (21.7)	0.43 (11)	1.26 (32)	1.78 (45.1)	9.61 (244)	M12x1.5; 17 deep
085	0.79 (20)	0.43 (11)	1.04 (26.5)	1.69 (43)	11.69 (297)	M12x1.5; 18 deep

L*) Up to mounting flange

5.10.6 Axial piston unit with through-drive SAE B-B



Note

O-ring for sealing of axial piston unit 2 is included in the scope of delivery.
NS 028 / 045: The following applies to control type VE_/VK_ and LR-; total length up to mounting flange L + 0.51 inch (13 mm).

Shaft gearing: 1 in 15T 16/32DP

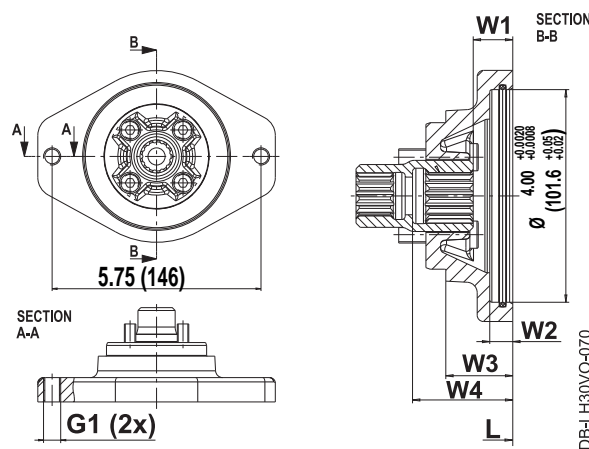

B21D 2-hole

NS	W1	W2	W3	W4	L	G1 (2-hole)
028	-	-	-	-	-	-
045	0.82 (20.9)	0.43 (11)	1.26 (32)	1.96 (49.9)	9.61 (244)	M12x1.75; 17 deep
085	0.87 (22.2)	0.43 (11)	1.04 (26.5)	1.89 (48)	11.69 (297)	M12x1.75; 18 deep

L*) Up to mounting flange
- not possible

5 Dimensions

Axial piston pump
LH30VO 028 to 085

5.10.7 Axial piston unit with through-drive SAE C



Note

O-ring for sealing of axial piston unit 2 is included in the scope of delivery.

Shaft gearing: 1 1/4 in 14T 12/24DP

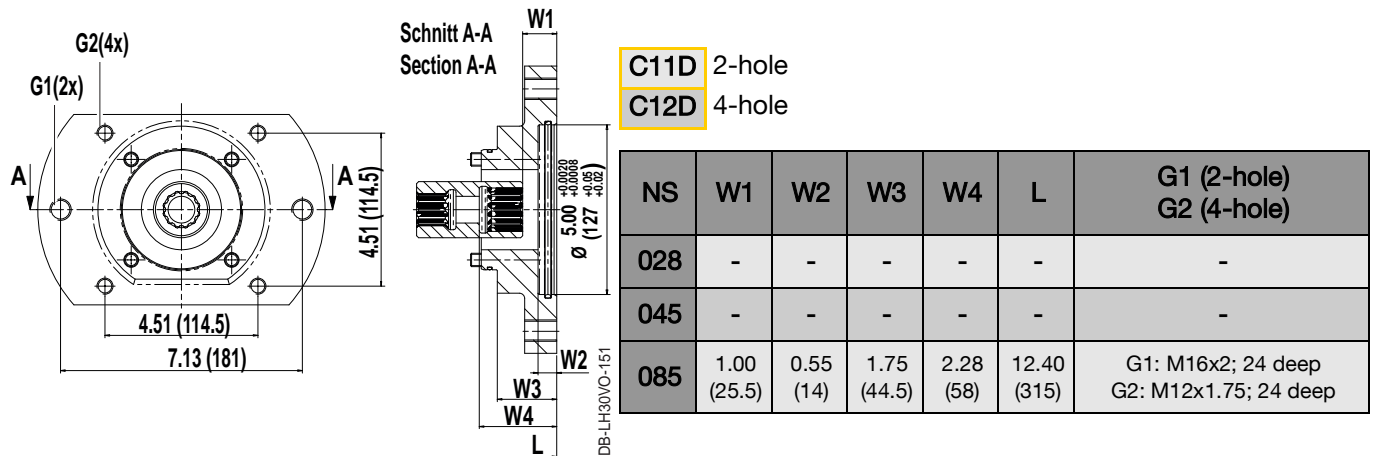

5.10.8 Axial piston unit with through-drive SAE C-C



Note

O-ring for sealing of axial piston unit 2 is included in the scope of delivery.

Shaft gearing: 1 1/2 in 17T 12/24DP

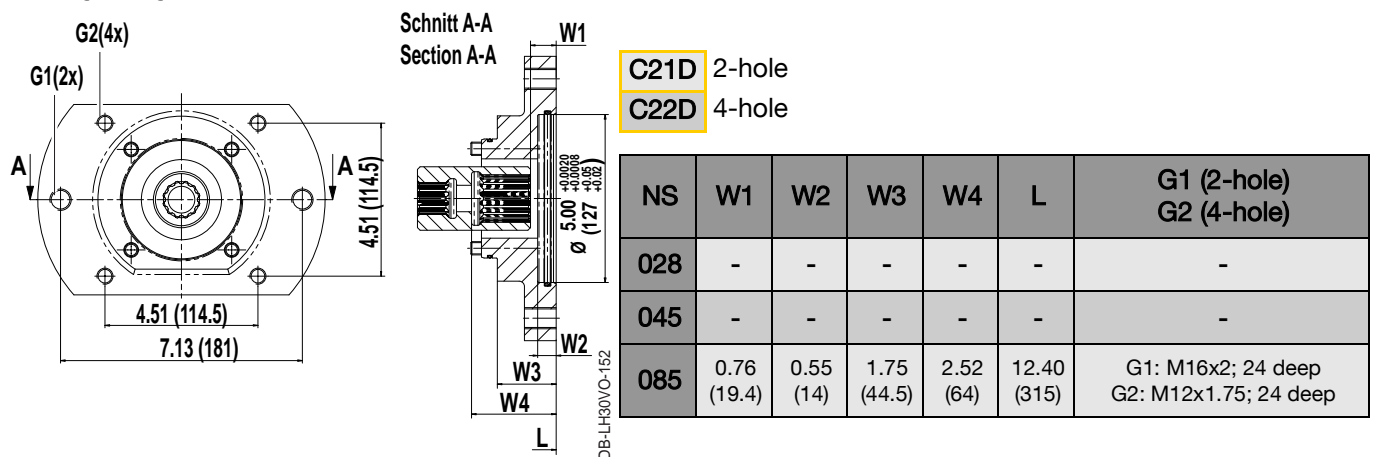

5 Dimensions

Axial piston pump
LH30VO 028 to 085

5.11 Multiple axial piston unit

General information

On request, multiple axial piston units consisting of 2 or more individual units can be implemented.

The type code must be completed separately for each individual unit. These type codes must be separated with a dash when ordering.

On the separate type plate for the multiple unit, the nominal sizes are separated by a "+". The last nominal size is followed only by the code for the direction of rotation. (Spaces before and after the letter are mandatory)

1.	2.	3.	4.	5.	6.	7.	11.
L	H	3	8	V	O	045+045...	

Type code 4 on the type plate changes from 0 to 8 for the design and the multiple unit is designated as LH38VO.

Details of the individual units can be found on the type plate of each individual unit.

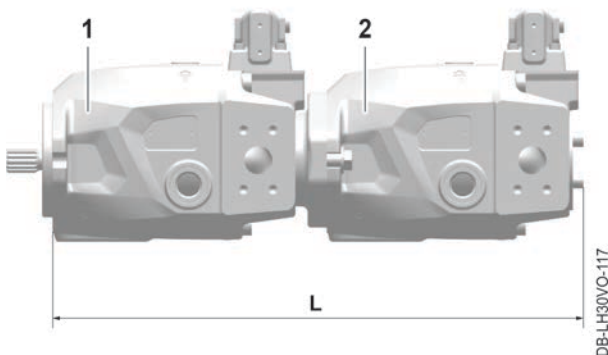

1	Basic axial piston unit
2	Add-on axial piston unit

L	Total length of multi-circuit axial piston unit in inch (mm)
-	-

5 Dimensions

Axial piston pump
LH30VO 028 to 085

5.11.1 Dimensions of the multiple unit

Basic axial piston unit 1		Add-on axial piston unit 2 with type code for through-drive					
		NS 028		NS 045		NS 085	
Nominal size	Through-drive type code	K02G	K02G with VE_/VK_/LR-	K02G	K02G with VE_/VK_/LR-	K02G	K02G with VE_/VK_/LR-
NS 028	A11D	■	■	-	-	-	-
	A21D	■	■	-	-	-	-
	B11D	L = 16.71 (424.5)	L = 17.07 (433.7)	-	-	-	-
	B21D						
NS 045	A11D	■	■	■	■	-	-
	A21D	■	■	■	■	-	-
	B11D	L = 17.66 (448.5)	L = 18.00 (457.1)	L = 18.60 (472.5)	L = 18.67 (474.1)	-	-
	B21D						
NS 085	A11D	■	■	■	■	■	■
	A21D	L = 19.47 (494.5)	L = 19.83 (503.7)	L = 20.41 (518.5)	L = 20.48 (520.1)	L = 22.72 (577)	L = 22.77 (578.4)
	B11D	■	■	■	■	■	■
	B21D	L = 19.74 (501.5)	L = 20.11 (510.7)	L = 20.69 (525.5)	L = 20.75 (527.1)	L = 22.99 (584)	L = 23.05 (585.4)
	C11D	■	■	■	■	■	■
	C21D	L = 20.45 (519.5)	L = 20.81 (528.7)	L = 21.40 (543.5)	L = 21.46 (545.1)	L = 23.70 (602)	L = 23.76 (603.4)

- = Available
- = Available on request
- = Not possible
- L* = Total length in inch (mm)



Changes, conditions, copyright

For the purposes of technical development, we reserve the right to make changes without prior notice.

©: Information and images in this data sheet may not be reproduced or distributed and may not be used for purposes of competition. All rights under the Copyright Act are expressly reserved by Liebherr, including for intellectual property applications.

The information in this data sheet does not release the user from their obligation to make their own assessments and tests.

The data sheet mainly shows an example configuration (LH30VO 045), unless otherwise indicated. The product delivered to you may therefore differ from the product illustrated.

Deviations are also possible in terms of data and values in this data sheet; these are only used to pre-select the product configuration and are not binding. The values are always values for the example configuration (LH30VO 045), unless otherwise indicated. Always use the values from the installation drawing supplied to you.

The information above does not extend the warranty and liability conditions in the General Terms and Conditions of Liebherr Machines Bulle SA and Liebherr-Components AG.

Sales

Liebherr-Components AG

PO Box 222, CH-5415 Nussbaumen /AG

☎ +41 56 296 43 00, Fax +41 56 296 43 01

www.liebherr.com, e-mail: info.cos@liebherr.com

Development / Production

Liebherr Machines Bulle SA

Rue Hans-Liebherr 7, CH-1630 Bulle / FR

☎ +41 26 913 3479, Fax.: +41 26 913 3485

www.liebherr.com, e-mail: info.lmb@liebherr.com