

# Axial piston variable pump A4VSG series 1x and 3x

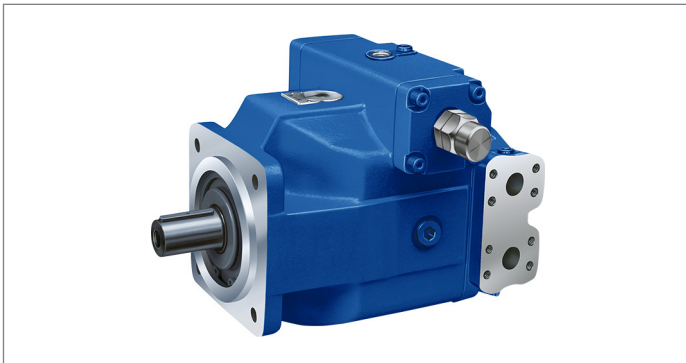

- ▶ Robust high-pressure pump for industrial applications
- ▶ Sizes 40... 1000
- ▶ Nominal pressure 350 bar
- ▶ Maximum pressure 400 bar
- ▶ Closed circuit

## Features

- ▶ Robust pump with very long service life
- ▶ Low operating noise
- ▶ Through-drive for mounting of further pumps up to same size
- ▶ Flow direction changes when the swashplate is moved through the neutral position
- ▶ Axial and radial load capacity of drive shaft
- ▶ Modular design
- ▶ Optical swivel angle indicator
- ▶ Short control times
- ▶ Operation on HF-fluids under reduced operational data possible
- ▶ Swashplate design

## Contents

Type code	2
Hydraulic fluids	5
Working pressure range	7
Technical data	8
Overview of control device	10
Dimensions, size 40 to 1000	14
Dimensions for through drives	32
Combination pumps A4VSG + A4VSG	45
Combination pumps A4VSG + A4VSO	45
Attachment of boost and control circuit pumps	
Order code: H02, H04 and H06	47
H024 – A4VSG with an attachment pump for the boost circuit, valve block with filter	48
For example: A4VSG 180....H024N	49
N009N – A4VSG with valve block without filter	50
A4VSG 1000....N009N	50
Installation instructions	51
Project planning notes	54
Safety instructions	55
Related documentation	56

## Type code

01	02	03	04	05	06	07	08	09	10	11	12	13	14
	<b>A4VS</b>	<b>G</b>			/		-			<b>10</b>			

Hydraulic fluid		40	71	125	180	250	355	500	750	1000	
01	Mineral oil and HFD hydraulic fluids (no code)	●	●	●	●	●	●	●	●	●	
	HFA, HFB, and HFC hydraulic fluids Only with sealing material NBR nitrile rubber and shaft seal PTFE. Please order with code P in position 08.	●	●	●	●	●	●	●	-	-	<b>E</b>

Axial piston unit		A4VS
02	Swashplate design, variable, nominal pressure 350 bar, maximum pressure 400 bar	<b>A4VS</b>

Operating mode		G
03	Pump, closed circuit	<b>G</b>

Size (NG)		40	71	125	180	250	355	500	750	1000
04	Geometric displacement, see table of values on page 8	<b>40</b>	<b>71</b>	<b>125</b>	<b>180</b>	<b>250</b>	<b>355</b>	<b>500</b>	<b>750</b>	<b>1000</b>

Control device		Data sheet	40	71	125	180	250	355	500	750	1000	
05	Manual control	92072	●	●	●	●	●	●	●	-	-	<b>MA</b>
	Electric motor control		●	●	●	●	●	●	●	-	-	<b>EM</b>
	Hydraulic control, depending on quantity	92076	●	●	●	●	●	●	●	●	●	<b>HM..</b>
	Digital, electro-hydraulic control, with control valve		●	●	●	●	●	●	●	●	●	<b>HS5.</b>
	Hydraulic control, with proportional valve		●	●	●	●	●	●	●	●	●	<b>EO..</b>
	Hydraulic control, pilot-pressure related	92080	●	●	●	●	●	●	●	●	●	<b>HD..</b>
	Electro-hydraulic control with proportional solenoid	92084	●	●	●	●	●	●	●	●	○	<b>EP..</b>
	Secondary controlled rotational speed control	92058	●	●	●	●	●	●	●	●	●	<b>DS2</b>
Secondary controlled rotational speed control	92063	●	●	●	●	●	●	●	●	●	<b>DS3</b>	

Series		40	71	125	180	250	355	500	750	1000	
06	Series 1, index 0 (index 1)	●	●	-	-	-	-	-	-	-	<b>10(11)<sup>2)</sup></b>
	Series 3, index 0	-	-	●	●	▲	●	▲	●	●	<b>30</b>
	Series 3, index 3; efficiency-optimized rotary group	-	-	-	-	●	-	●	-	-	<b>33</b>

Direction of rotation		40	71	125	180	250	355	500	750	1000		
07	Viewed on drive shaft	Clockwise	●	●	●	●	●	●	●	●	●	<b>R</b>
		Counter-clockwise	●	●	●	●	●	●	●	●	●	<b>L</b>
		Variable	●	●	●	●	●	●	●	●	●	<b>W<sup>1)</sup></b>

Sealing material		40	71	125	180	250	355	500	750	1000	
08	FKM (fluorocarbon rubber) / HFD operation	●	●	●	●	●	●	●	●	●	<b>V</b>

Drive shaft		40	71	125	180	250	355	500	750	1000	
09	Parallel keyed shaft DIN 6885	●	●	●	●	●	●	●	●	●	<b>P</b>
	Splined shaft DIN 5480	●	●	●	●	●	●	●	●	●	<b>Z</b>

Mounting flange		40	71	125	180	250	355	500	750	1000		
10	In accordance with ISO 3019-2 metric	4-hole	●	●	●	●	●	●	-	-	-	<b>B</b>
		8-hole	-	-	-	-	-	-	●	●	●	<b>H</b>

Working port		40	71	125	180	250	355	500	750	1000	
11	SAE flange ports <b>A</b> and <b>B</b> , located on same side, metric fastening thread	●	●	●	●	●	●	●	●	●	<b>10</b>











● = Available    ○ = On request    - = Not available    ▲ = Not for new projects

1) Only in combination with DS2 and DS3

2) Version with HD and EP-controls in series 11

01	02	03	04	05	06	07	08	09	10	11	12	13	14
	<b>A4VS</b>	<b>G</b>			/			-			<b>10</b>		

**Through drives** (for mounting options, see page 44)

12	Flange ISO 3019-2 (metric)	Hub for splined shaft											
	Diameter	Mounting <sup>5)</sup>	Diameter	<b>40</b>	<b>71</b>	<b>125</b>	<b>180</b>	<b>250</b>	<b>355</b>	<b>500</b>	<b>750</b>	<b>1000</b>	
	Without through drive			●	●	●	●	●	●	●	●	●	<b>N00</b>
	125, 4-hole		32 x 22 x 14 x 9 g <sup>3)</sup>	●	●	●	●	●	○	●	○	○	<b>K31</b>
	140, 4-hole		40x2x18x9g <sup>3)</sup>	-	●	●	●	●	●	●	○	●	<b>K33</b>
	160, 4-hole		50x2x24x9g <sup>3)</sup>	-	-	●	●	●	●	●	○	●	<b>K34</b>
	224, 4-hole		60x2x28x9g <sup>3)</sup>	-	-	-	-	●	●	●	●	●	<b>K35</b>
	224, 4-hole		70x3x22x9g <sup>3)</sup>	-	-	-	-	-	●	●	○	●	<b>K77</b>
	315, 8-hole		80x3x25x9g <sup>3)</sup>	-	-	-	-	-	-	●	●	●	<b>K43</b>
	400, 8-hole		90x3x28x9g <sup>3)</sup>	-	-	-	-	-	-	-	●	●	<b>K76</b>
	400, 8-hole		100x3x32x9g <sup>3)</sup>	-	-	-	-	-	-	-	-	●	<b>K88</b>
	80, 2-hole		3/4 in 11T 16/32DP <sup>4)</sup>	○	●	●	○	○	○	○	○	○	<b>KB2</b>
	100, 2-hole		7/8 in 13T 16/32DP <sup>4)</sup>	●	●	●	●	●	●	○	○	○	<b>KB3</b>
	100, 2-hole		1 in 15T 16/32DP <sup>4)</sup>	○	●	●	●	●	●	○	○	●	<b>KB4</b>
	125, 2-hole		1 1/4 in 14T 12/24DP <sup>4)</sup>	-	●	●	●	●	●	●	○	○	<b>KB5</b>
	160, 4-hole		1 1/4 in 14T 12/24DP <sup>4)</sup>	○	○	○	○	○	○	○	○	○	<b>KB8</b>
	125, 2-hole		1 1/2 in 17T 12/24DP <sup>4)</sup>	-	-	●	●	●	●	●	●	○	<b>KB6</b>
	180, 4-hole		1 1/2 in 17T 12/24DP <sup>4)</sup>	-	-	○	○	○	○	○	○	○	<b>KB9</b>
	180, 4-hole		1 3/4 in 13T 8/16DP <sup>4)</sup>	-	-	●	●	●	●	●	●	○	<b>KB7</b>
	Flange ISO 3019-1 (SAE)		Hub for splined shaft										
	Diameter	Mounting <sup>5)</sup>	Diameter										
	Through drive			<b>40</b>	<b>71</b>	<b>125</b>	<b>180</b>	<b>250</b>	<b>355</b>	<b>500</b>	<b>750</b>	<b>1000</b>	
	82-2 (A)		5/8 in 9T 16/32DP <sup>4)</sup>	●	●	●	●	●	●	●	●	○	<b>K01</b>
	82-2 (A)		3/4 in 11T 16/32DP <sup>4)</sup>	○	●	○	●	○	●	○	○	○	<b>K52</b>
	101-2 (B)		7/8 in 13T 16/32DP <sup>4)</sup>	●	●	●	●	●	●	●	●	○	<b>K68</b>
	101-2 (B)		1 in 15T 16/32DP <sup>4)</sup>	●	●	●	●	●	●	●	○	○	<b>K04</b>
	127-2 (C)		1 1/4 in 14T 12/24DP <sup>4)</sup>	-	●	●	●	●	●	●	●	●	<b>K07</b>
	127-2 (C)		1 1/2 in 17T 12/24DP <sup>4)</sup>	-	-	●	●	●	●	●	●	●	<b>K24</b>
	152-4 (D)		1 3/4 in 13T 8/16DP <sup>4)</sup>	-	-	●	●	●	●	●	●	○	<b>K17</b>
	Prepared for through drive, with pressure-proof plugged cover			●	●	●	●	●	●	●	●	●	<b>K99</b>
	<b>Boost pump<sup>6)</sup></b>												
	A piped up attachment pump for the boost circuit			●	●	●	●	▲	▲	▲	▲	●	<b>H02</b>
	A shared piped up attachment pump for the boost and control circuit (only for EO1 and EO1K)			●	●	●	-	-	-	-	▲	-	<b>H04</b>
	A separate piped up attachment pump for the boost circuit and the control circuit (only for HD1T and HD1U) including pressure relief valve for the control circuit			●	●	●	●	▲	▲	▲	▲	●	<b>H06</b>

● = Available    ○ = On request    - = Not available    ▲ = Not for new projects

3) According to DIN 5480

4) In accordance with ANSI B92.1a

5) Mounting holes pattern viewed on through drive with control at top.

6) For boost pump attachment NG250 to 750, please use A4CSG (see data sheet 92105). An overview of the available boost pumps for the NG40 to 180 and 1000 can be found on page 47.

4 **A4VSG series 1x and 3x** | Axial piston variable pump  
Type code

01	02	03	04	05	06	07	08	09	10	11	12	13	14
	<b>A4VS</b>	<b>G</b>			/			-				<b>10</b>	

<b>Valves</b>		40	71	125	180	250	355	500	750	1000	
13	Without valve block	●	●	●	●	●	●	●	●	●	0
	<b>SDVB</b> valve block mounted Data sheet 95533	▲	▲	▲	▲	▲ <sup>9)</sup>	▲ <sup>9)</sup>	▲ <sup>9)</sup>	▲ <sup>9)</sup>	●	9
	Valve block mounted <b>SDVB 16</b> (With directly controlled flushing slide and pilot operated high-pressure relief valve) Data sheet 95534	●	●	●	●	-	-	-	-	-	4

<b>Filtration</b>		40	71	125	180	250	355	500	750	1000	
14	Without filter	●	●	●	●	●	●	●	●	●	N
	Filter mounted in boost circuit	●	●	●	●	●	●	●	●	●	F <sup>7)</sup>
	Intermediate plate filter (for DS-control, see data sheet 92058 and 92063)	●	●	●	●	●	●	● <sup>8)</sup>	●	●	Z
	With threaded port for filter in the boost circuit (only for valve block SDVB 16 acc. to data sheet 95534)	●	●	●	●	-	-	-	-	-	D

● = Available    ○ = On request    - = Not available

▲ = Not for new projects

**Notice**

- ▶ Note the project planning notes on page 55.
- ▶ In addition to the type code, please specify the relevant technical data when placing your order.
- ▶ For information on the mounting situation of combination pumps, see page 45.

<sup>7)</sup> Filter in the boost circuit with visual-electrical contamination indicator in standard version for:

- NG40, 71: LFBN/HC60G20D1.0/V-L24
- NG125, 180: LFBN/HC110G20D1.0/V-L24
- NG250, 355: LFBN/HC240G20D1.0/V-L24
- NG500: LFBN/HC330G20D1.0/V-L24
- NG750, 1000: LFBN/HC660G20D1.0/V-L24

Please contact us for more information on the filter.

<sup>8)</sup> For size 500, only available for DS control; see data sheet 92058

<sup>9)</sup> For valve block attachment for NG250 to 750, please use A4CSG (see data sheet 92105).

## Hydraulic fluids

The A4VSG variable pump is designed for operation with HLP mineral oil according to DIN 51524.

Application instructions and requirements for hydraulic fluid selection, behavior during operation as well as disposal and environmental protection should be taken from the following data sheets before the start of project planning:

- ▶ 90220: Hydraulic fluids based on mineral oils and related hydrocarbons
- ▶ 90221: Environmentally acceptable hydraulic fluids
- ▶ 90222: Fire-resistant, water-free hydraulic fluids (HFDR/HFDU)

### Selection of hydraulic fluid

Bosch Rexroth evaluates hydraulic fluids on the basis of the Fluid Rating according to the technical data sheet 90235.

Hydraulic fluids with positive evaluation in the Fluid Rating are listed in the following data sheet:

- ▶ 90245 Bosch Rexroth fluid rating list for Rexroth hydraulic components (pumps and motors)

The hydraulic fluid should be selected so that the operating viscosity in the operating temperature range is within the optimum range ( $v_{opt}$ ; see selection diagram).

### Viscosity and temperature of hydraulic fluids

	Viscosity	Shaft seal	Temperature <sup>2)</sup>	Comment
Cold start	$v_{max} \leq 1600 \text{ mm}^2/\text{s}$	FKM	$\vartheta_{St} \geq -25^\circ\text{C}$	$t \leq 3 \text{ min}$ , without load ( $p \leq 50 \text{ bar}$ ), $n \leq 1000 \text{ rpm}$ Permissible temperature difference between axial piston unit and hydraulic fluid in the system maximum 25 K
Warm-up phase	$v = 1600 \dots 400 \text{ mm}^2/\text{s}$			$t \leq 15 \text{ min}$ , $p \leq 0.7 \times p_{nom}$ and $n \leq 0.5 \times n_{nom}$
Permissible operating range	$v = 400 \dots 10 \text{ mm}^2/\text{s}^{1)}$	FKM	$\vartheta \leq +110^\circ\text{C}$	Measured at port <b>T</b>
	$v_{opt} = 36 \dots 16 \text{ mm}^2/\text{s}$			Optimal operating viscosity and efficiency range
Short-term operation	$v_{min} = 10 \dots 7 \text{ mm}^2/\text{s}$	FKM	$\vartheta \leq +110^\circ\text{C}$	$t \leq 3 \text{ min}$ , $p \leq 0.3 \times p_{nom}$ , measured at port <b>T</b>

#### ▼ Selection diagram

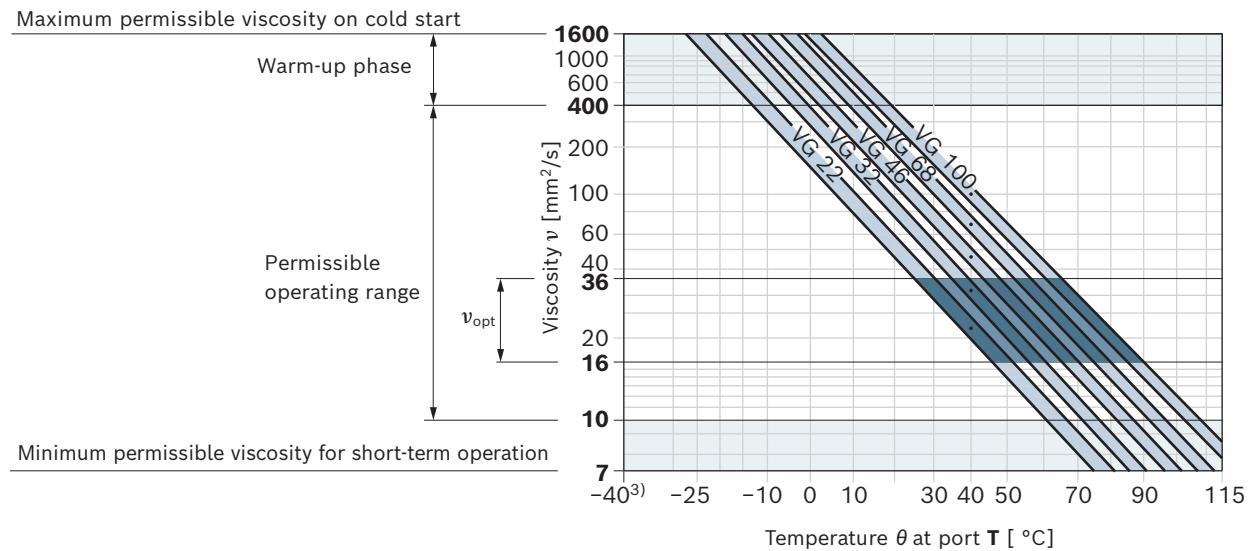

#### Notice

The maximum circuit temperature of  $+115^\circ\text{C}$  must not be exceeded at the working ports **A** and **B** complying with the permissible viscosity.

1) This corresponds, for example on the VG 46, to a temperature range of  $+4^\circ\text{C}$  to  $+85^\circ\text{C}$  (see selection diagram)

2) If the temperature at extreme operating parameters cannot be adhered to, please contact us.

3) For applications in the low-temperature range, please contact us.

### Filtration of the hydraulic fluid

Finer filtration improves the cleanliness level of the hydraulic fluid, which increases the service life of the axial piston unit.

A cleanliness level of at least 20/18/15 under ISO 4406 should be maintained.

At a hydraulic fluid viscosity of less than 10 mm<sup>2</sup>/s (e.g. due to high temperatures during short-term operation), a cleanliness level of at least 19/17/14 according to ISO 4406 is required.

For example, a viscosity of 10 mm<sup>2</sup>/s corresponds at

- HLP 32 a temperature of 73 °C
- HLP 46 a temperature of 85 °C

### Bearing flushing

Bearing flushing is required for a safe, continuous operation under the following operating conditions:

- ▶ Applications with water-containing special fluids due to limited lubricity and narrow operating temperature range
- ▶ Operation with borderline conditions for temperature and viscosity
- ▶ With vertical installation (drive shaft facing upwards) for lubricating the front bearing and the shaft seal.

Bearing flushing is realized at port **U** in the area of the front flange of the variable pump. The flushing fluid flows through the front bearing and discharges with the pump drain at the drain port.

The following flushing flows are recommended depending on size:

NG	40	71	125	180	250	355	500	750	1000
$q_{Sp}$ l/min	3	4	5	7	10	15	20	30	40

For the flushing flows stated, there is a pressure differential of about 2 or 3 bar between port **U** (including fitting) and the housing area (series 1x and series 3x, respectively).

#### Notice regarding series 3x

When using external bearing flushing, the throttle screw in port **U** must be turned to the stop.

### Shaft seal

Permissible pressure load

The service life of the shaft seal is influenced by the rotational speed of the axial piston unit and the leakage pressure in the housing (case pressure). Momentary ( $t < 0.1$  s) pressure peaks of up to 6 bar absolute are acceptable. The service life of the shaft seal decreases with increasing frequency of pressure peaks and increasing mean differential pressure. A slide ring seal is available for higher housing pressures.

The pressure in the housing must be equal to or greater than the ambient pressure.

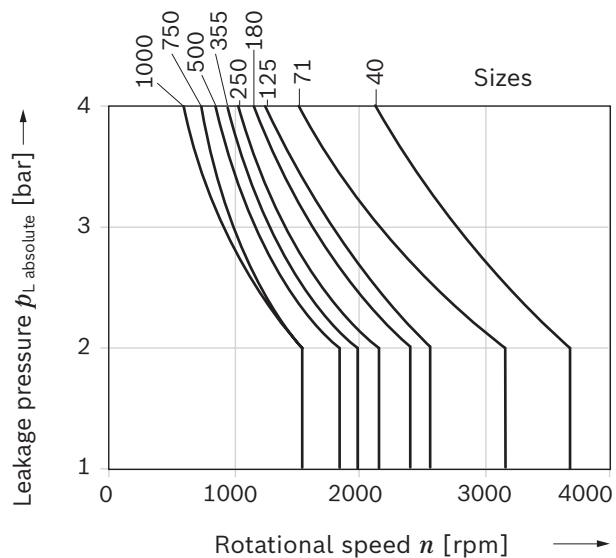

#### Notice

For details on the viscosity and temperatures of the hydraulic fluids, please see page 5.

### Flow direction

Direction of rotation		Swiveling range
Clockwise	Counter-clockwise	
<b>B to A</b>	<b>A to B</b>	Clockwise
<b>A to B</b>	<b>B to A</b>	Counter-clockwise

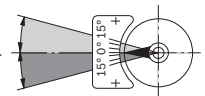

## Working pressure range

Pressure at working port A or B		Definition
Nominal pressure $p_{nom}$	350 bar	The nominal pressure corresponds to the maximum design pressure.
Maximum pressure $p_{max}$	400 bar	The maximum pressure corresponds to the maximum working pressure within a single operating period. The sum of single operating periods must not exceed the total operating period.
Single operating period	1 s	
Total operating period	300 h	
Minimum pressure (high-pressure side)	15 bar	Minimum pressure at the high-pressure side ( <b>A</b> or <b>B</b> ) which is required to prevent damage to the axial piston unit.
Minimum pressure (low-pressure side)		Minimum pressure on the low-pressure side ( <b>A</b> or <b>B</b> ) required to prevent damage to the axial piston unit. The minimum pressure depends on the rotational speed and the boost pressure (see diagram).
Rate of pressure change $R_{A\ max}$	16000 bar/s	Maximum permissible speed of pressure build-up and reduction during a pressure change across the entire pressure range.
<b>Recommended boost pressure <math>p_{SP}</math> (input)</b> (for boost pumps, see page 47)		
	16 bar	Size 40 to 500 series 1x and 30
	10 bar	Sizes 250 and 500 series 33
	25 bar	Size 750 to 1000 series 30
	25 bar	For a shared attachment pump for boost and control fluid circuit (EO1...H04)
Maximum boost pressure - attachment pump $p_{S\ max}$ at control <sup>1)</sup> :		
MA, EM, HM, EO, DS	50 bar	For information on the control pressure, see the respective data sheets on page 2
HD, EP, HS5x	not less than 15 bar, maximum 25 bar	
<b>Case pressure at connection <math>K_2, K_3, R(L)</math></b>		
Max. static pressure $p_{L\ max}$	4 bar absolute <sup>2)</sup>	The permissible case pressure depends on the rotational speed (see diagram). A drain line to the reservoir is required.
Pressure peaks $p_{L\ peak}$	6 bar absolute	$t < 0.1$ s

### ▼ Rate of pressure change $R_{A\ max}$

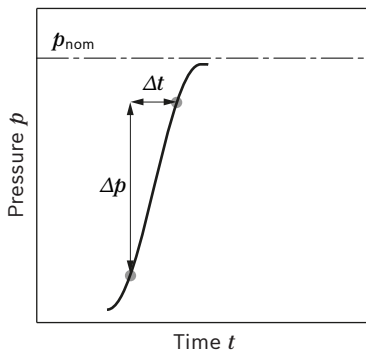

### ▼ Minimum pressure, low-pressure side (feed pressure)

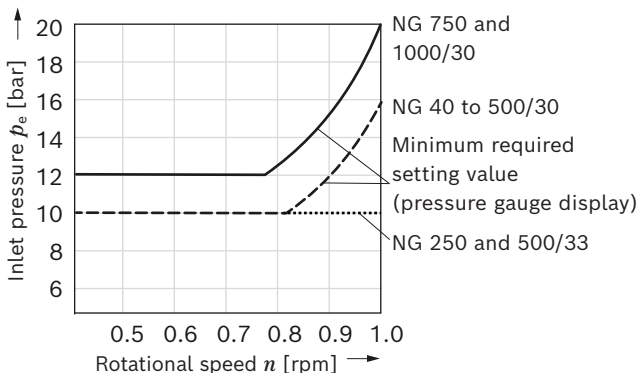

### ▼ Pressure definition

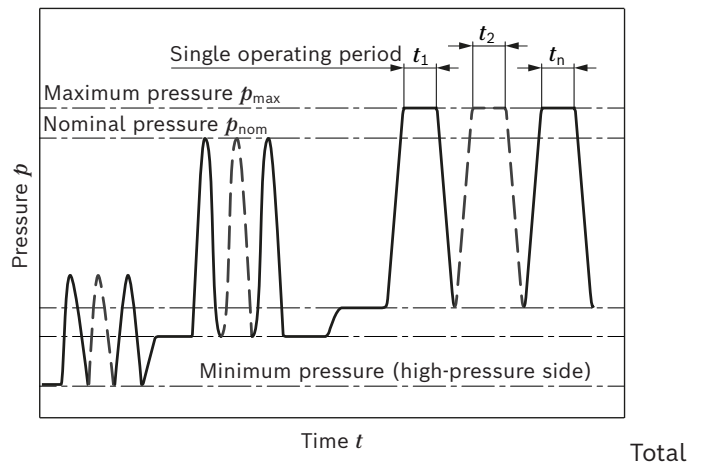

$$\text{Operating period} = t_1 + t_2 + \dots + t_n$$

#### Notice

Working pressure range applies when using hydraulic fluids based on mineral oils. Please contact us for values for other hydraulic fluids.

- 1) For permissible inlet pressure of the respective attachment pump, see the corresponding data sheet
- 2) Slide ring seal for housing pressures up to 8 bar absolute available, please contact us

## Technical data

Size	NG		40	71	125	180	250	355	500	750	1000
Geometric displacement, per revolution	$V_{g \max}$	cm <sup>3</sup>	40	71	125	180	250	355	500	750	1000
Maximum rotational speed <sup>1)</sup>	at $V_{g \max}$	$n_{\max}$	rpm	3700	3200	2600	2400	2200	2000	1800	1600
Flow	at $n_{\max}$ and $V_{g \max}$	$q_v$	l/min	148	227	325	432	550	710	900	1200
	at 1500 rpm and $V_{g \max}$			60	107	186	270	375	533	750	1125
Power	at $n_{\max}$ , $V_{g \max}$ and $\Delta p = 350$ bar	$P$	kW	86	132	190	252	321	414	525	700
	at 1500 rpm, $V_{g \max}$ and $\Delta p = 350$ bar			35	62	109	158	219	311	438	656
Torque	at $V_{g \max}$ and $\Delta p = 350$ bar	$M$	Nm	223	395	696	1002	1391	1976	2783	4174
	at $V_{g \max}$ and $\Delta p = 100$ bar			64	113	199	286	398	564	795	1193
Rotary stiffness of drive shaft	P	$c$	kNm/rad	80	146	260	328	527	800	1145	1860
	Z	$c$	kNm/rad	77	146	263	332	543	770	1136	1812
Moment of inertia of the rotary group	$J_{TW}$	kgm <sup>2</sup>	0.0049	0.0121	0.03	0.055	0.0959	0.19	0.3325	0.66	1.20
Maximum angular acceleration <sup>2)</sup>	$\alpha$	rad/s <sup>2</sup>	17000	11000	8000	6800	4800	3600	2800	2000	1450
Case volume	$V$	l	2	2.5	5	4	10	8	14	19	27
Weight approx.	$m$	kg	42	60	107	112	220	235	335	500	644

Determination of the characteristics		
Flow	$q_v = \frac{V_g \times n \times \eta_v}{1000}$	[l/min]
Torque	$M = \frac{V_g \times \Delta p}{20 \times \pi \times \eta_{hm}}$	[Nm]
Power	$P = \frac{2 \pi \times M \times n}{60000} = \frac{q_v \times \Delta p}{600 \times \eta_t}$	[kW]
Key		
$V_g$	=	Displacement per revolution [cm <sup>3</sup> ]
$\Delta p$	=	Differential pressure [bar]
$n$	=	Rotational speed [rpm]
$\eta_v$	=	Volumetric efficiency
$\eta_{hm}$	=	Hydraulic-mechanical efficiency
$\eta_t$	=	Total efficiency ( $\eta_t = \eta_v \times \eta_{hm}$ )

### Notice

- ▶ Theoretical values, without efficiency and tolerances; values rounded
- ▶ Operation above the maximum values or below the minimum values may result in a loss of function, a reduced service life or in the destruction of the axial piston unit. We recommend checking loads through tests or calculation/simulation and comparing them with the permissible values.

- 1) The values are applicable:
  - for the optimum viscosity range from  $\nu_{opt} = 36$  to  $16 \text{ mm}^2/\text{s}$
  - with hydraulic fluid based on mineral oils
- 2) The data are valid for values between the minimum required and maximum permissible rotational speed. Valid for external excitation (e.g. diesel engine 2 to 8 times rotary frequency; cardan shaft twice the rotary frequency). The limit value is only valid for a single pump. The load capacity of the connection parts must be considered.

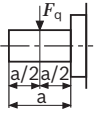
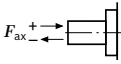

**Permissible radial and axial loading on the drive shafts**

Size	NG	40	71	125	180	250	355	500	750	1000		
Maximum radial force at distance $a/2$		$F_{q \max}$	N	1000	1200	1600	2000	2000	2200	2500	3000	3500
Maximum axial force		$+ F_{ax \max}$	N									
		$- F_{ax \max}$	N	600	800	1000	1400	1800	2000	2000	2200	2200

**Notice**

- ▶ The values given are maximum values and do not apply to continuous operation.
- All loads of the drive shaft reduce the bearing service life!

**Permissible input and through-drive torques**

Size	NG	40	71	125	180	250	355	500	750	1000			
Torque at $V_{g \max}$ and $\Delta p = 350 \text{ bar}^{1)}$	$M_{\max}$	Nm	223	395	696	1002	1391	1976	2783	4174	5565		
Max. input torque on drive shaft <sup>2)</sup>													
	Splined shaft	Z	$M_{E \max}$	Nm	446	790	1392	2004	2782	3952	5566	8348	11130
	Shaft key	P	$M_{E \max}$	Nm	380	700	1392	1400	2300	3557	5200	7513	9444
Maximum through-drive torque	$M_{D \max}$	Nm	223	395	696	1002	1391	1976	2783	4174	5565		

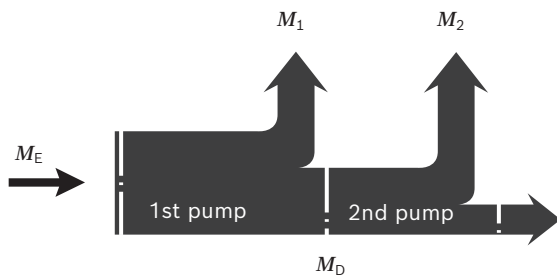
**▼ Distribution of torques**

Torque at 1st pump	$M_1$
Torque at 2nd pump	$M_2$
Torque at 3rd pump	$M_3$
Input torque	$M_E = M_1 + M_2 + M_3$
	$M_E < M_{E \max}$
Through-drive torque	$M_D = M_2 + M_3$
	$M_D < M_{D \max}$

**Notice**

- ▶ In case of through drive pumps as well as in case of bi-directional torque loads, the use of a splined shaft is recommended.

**Notice**

- ▶ In case of through drive pumps as well as in case of bi-directional torque loads, the use of a splined shaft is recommended.
- ▶ The through-drive torques apply to the through-drive shaft without hub:  
Prepared for through drive, with pressure-resistant plugged cover – order code K/U99.
- ▶ The permissible output torques of the supplied hub depend on the drive torques of the attachment pumps from the table:  
Overview of mounting options on page 44

1) Efficiency not considered

2) For drive shafts free of radial force

## Overview of control device

### Hydraulic control HM 1/2, volume dependent (see data sheet 92076)

The pump displacement can be steplessly varied in relation to the control oil volume in ports **X<sub>1</sub>** and **X<sub>2</sub>**.

Application:

- ▶ 2-point circuit
- ▶ Base device for servo or proportional controls

#### ▼ Circuit diagram HM1 NG125

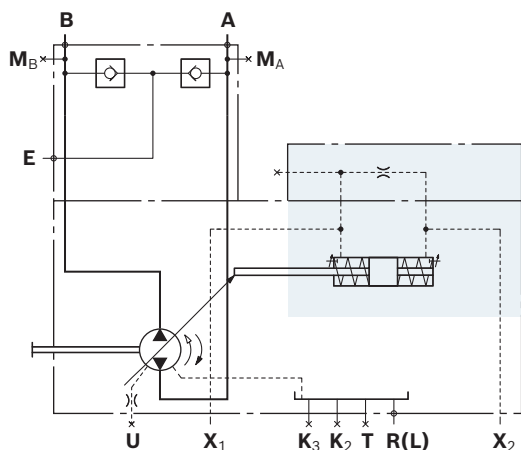

### Control system HS., HS5., HS5E., with proportional valve (see RE 92076)

The stepless displacement control is accomplished by means of a proportional valve and electrical feedback of the swivel angle.

The HS5(E)P control system is equipped with a mounted pressure transducer, which means that it can be used for electric pressure and power control.

Optional:

- ▶ Servo valve (HS);
- ▶ Proportional valve (HS5);
- ▶ With integrated control pressure supply (HS5L, HS5EL);
- ▶ Control system with integrated digital electronics OBE (HS5E)
- ▶ Short circuit valve (HSK, HS5(E)K, HS5(E)KP);
- ▶ For oil-immersed use (HS5M)

#### ▼ Characteristic curve HS5

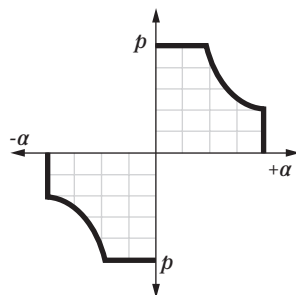

#### ▼ Circuit diagram HS5P NG500

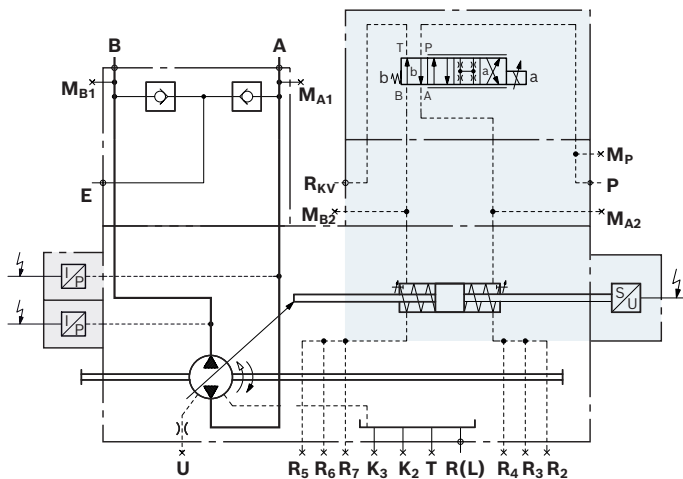

**Control system EO1/2**  
 (see RE 92076)

The stepless control of the displacement flow is accomplished by means of a proportional valve and electrical feedback of the swivel angle. Thus, the control can be used as an electric displacement control.

Optional:

- ▶ Control pressure range (EO1, EO2)
- ▶ Short circuit valve (EO1K, EO2K)

▼ **Characteristic curve EO**

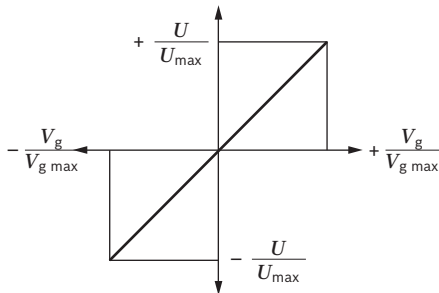

▼ **Circuit diagram HM1 NG125**

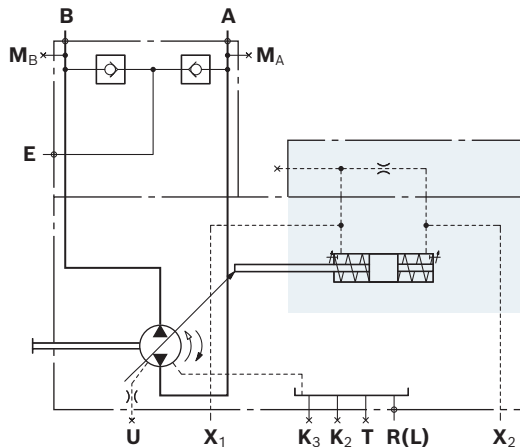

**Hydraulic control HD, pilot-pressure related**  
 (see data sheet 92080)

Stepless adjustment of the pump displacement according to the pilot pressure. The control is proportional to the specified pilot pressure (difference between pilot pressure and case pressure).

Optional:

- ▶ Control characteristics (HD1, HD2, HD3)
- ▶ Pressure control (HD.B),
- ▶ Remote pressure control (HD.GB)
- ▶ Power control (HD1P)
- ▶ Electrical control of pilot pressure (HD1T)

▼ **Characteristic curve HD**

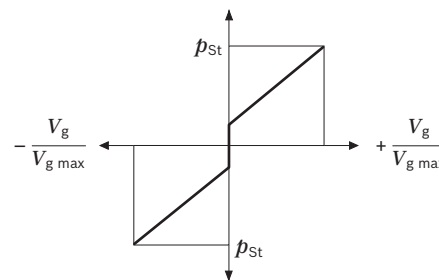

▼ **Circuit diagram HD**

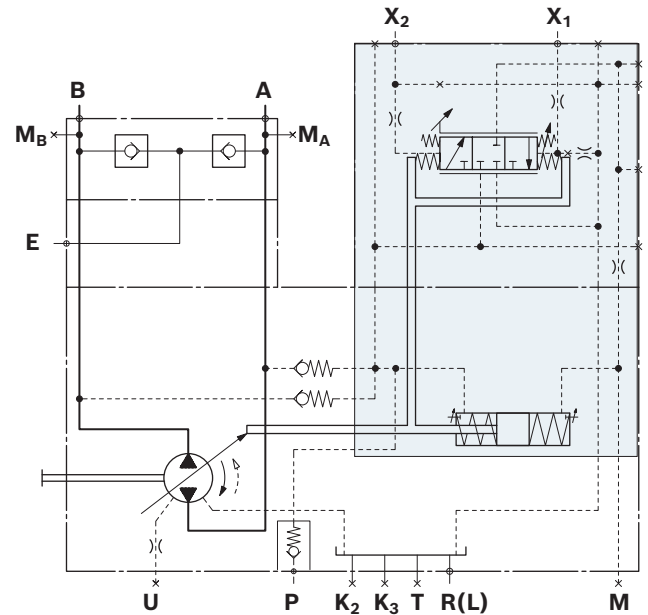

**Electro-hydraulic control EP with proportional solenoid  
 (see data sheet 92084)**

The EP control adjusts the pump displacement proportionally to the current at the solenoid. Current-regulated control units with pulse width modulation are recommended for controlling the solenoids.

Optional:

- ▶ Pressure control (EPA, EPB, EPD)
- ▶ Remote pressure control (EPGA, EPGB, EPG)

▼ **Characteristic curve EP**

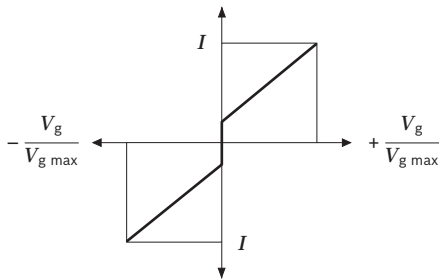

▼ **Circuit diagram EP**

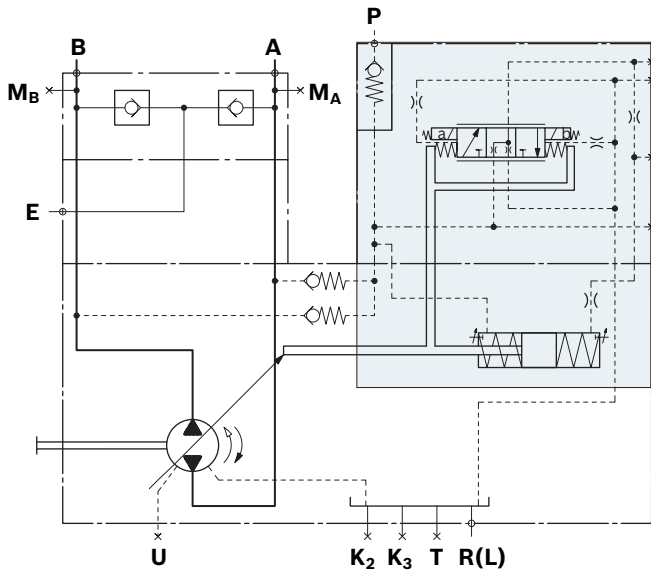

**Secondary controlled rotational speed control DS.**  
**(see data sheet 92058 (DS2) data sheet 92059 (DS3))**

The rotational speed control DS2 and DS3 controls the secondary unit in such a manner, that this motor delivers sufficient torque to maintain the required rotational speed. When connected to a constant pressure system, this torque is proportional to motor displacement and thus also proportional to the swivel angle.

▼ **Characteristic curve DS2/DS3**

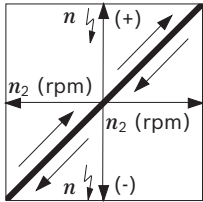

▼ **Example circuit diagram DS2**

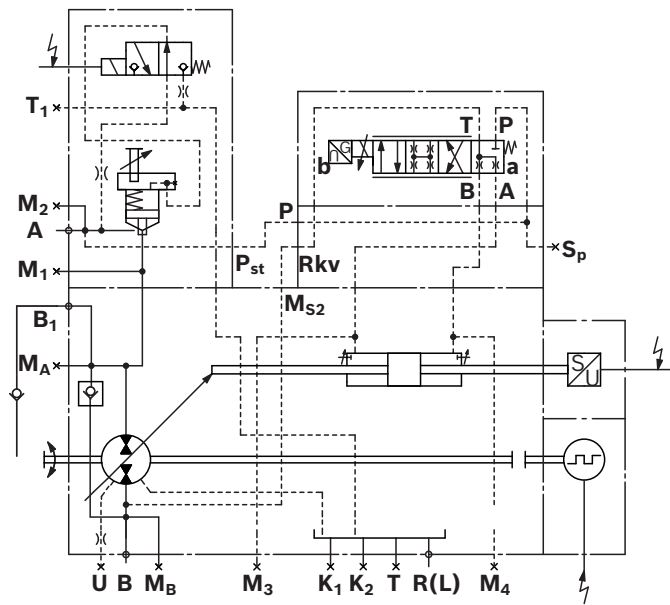

### Dimensions, size 40

Example: **HM – Hydraulic control, control volume dependent**, for additional dimensions, see data sheets for the controls

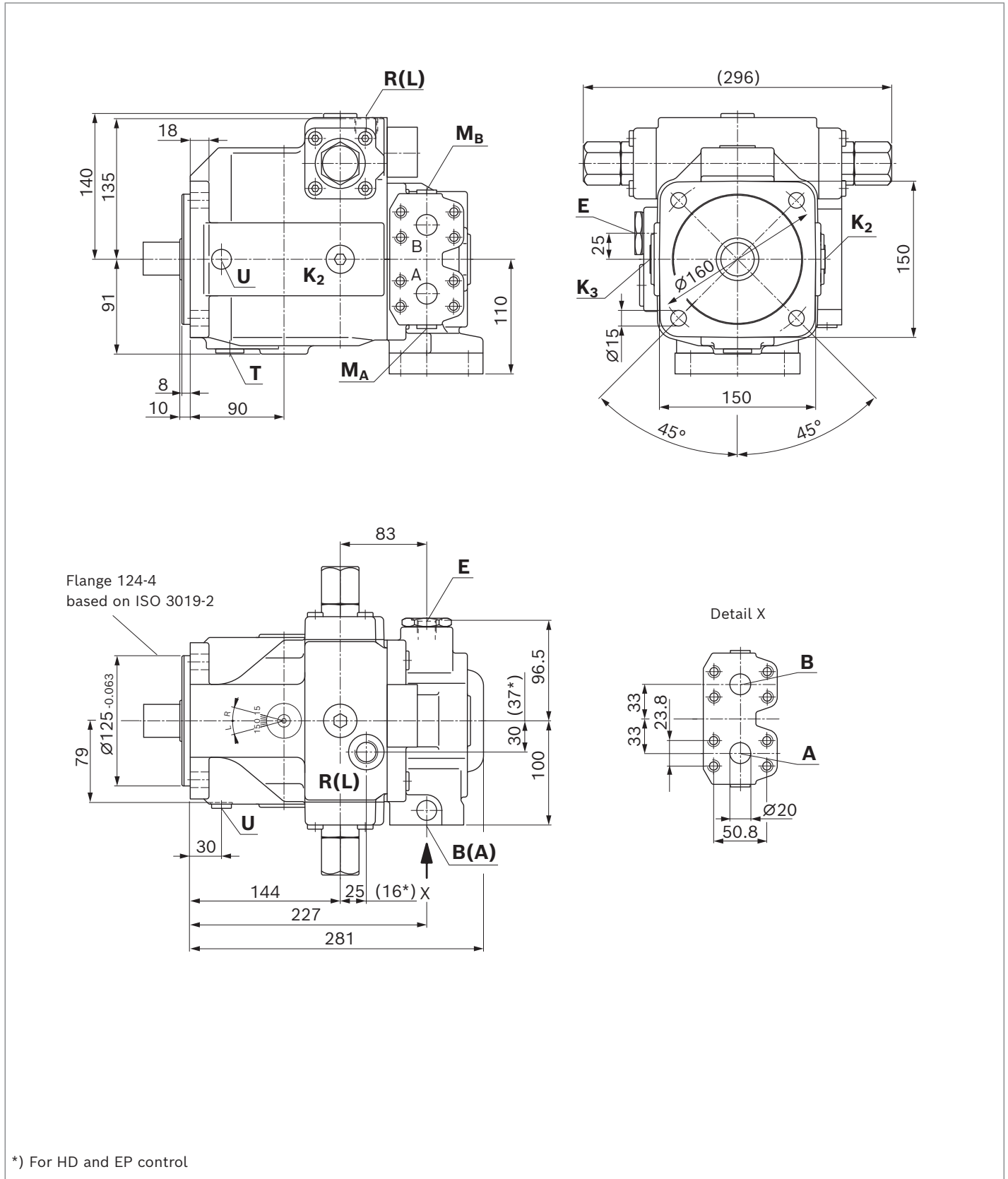

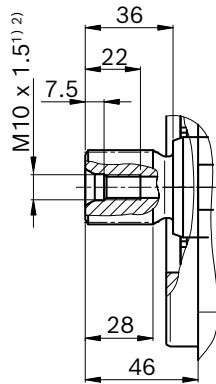
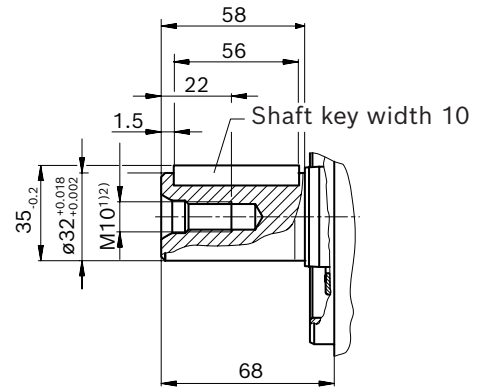
▼ **Splined shaft DIN 5480****Z** – W32x2x14x9g▼ **Parallel keyed shaft DIN 6885****P** – AS10x8x56

Ports		Standard	Size	$p_{\max}$ [bar] <sup>3)</sup>	State <sup>7)</sup>
<b>A, B</b>	Working port (high-pressure series) Fastening thread	SAE J518 <sup>4)</sup> DIN 13	3/4 in M10 × 1.5; 17 deep	400	O
<b>M<sub>A</sub>, M<sub>B</sub></b>	Measuring working pressure <b>A/B</b>	DIN 3852	M14 × 1.5; 12 deep	400	X
<b>T</b>	Fluid drain	DIN 3852 <sup>5)</sup>	M22 × 1.5; 14 deep	5	X <sup>6)</sup>
<b>E</b>	Boost pressure supply	DIN 3852	M18 × 1.5; 12 deep	50	O
<b>K<sub>2</sub>, K<sub>3</sub></b>	Filling – air bleeding, return flow (drain port)	DIN 3852 <sup>5)</sup>	M22 × 1.5; 14 deep	5	X <sup>6)</sup>
<b>R(L)</b>	Filling – air bleeding, return flow (drain port)	DIN 3852 <sup>5)</sup>	M22 × 1.5; 14 deep	5	O <sup>6)</sup>
<b>U</b>	Bearing flushing	DIN 3852 <sup>5)</sup>	M14 × 1.5; 12 deep	7	X

1) Center bore according to DIN 332

2) Thread according to DIN 13

3) Depending on the application, momentary pressure peaks can occur. Keep this in mind when selecting measuring devices and fittings.

4) Metric fastening thread is a deviation from standard.

5) The countersink may be deeper than specified in the standard.

6) Depending on the installation position **T**, **K<sub>1</sub>**, **K<sub>2</sub>** or **R(L)** must be connected (see also installation instructions on pages 51 to 53)

7) O = Must be connected (plugged on delivery)

X = Plugged (in normal operation)

## Dimensions, size 71

Example: **HM – Hydraulic control, control volume dependent**, for additional dimensions, see data sheets for the controls

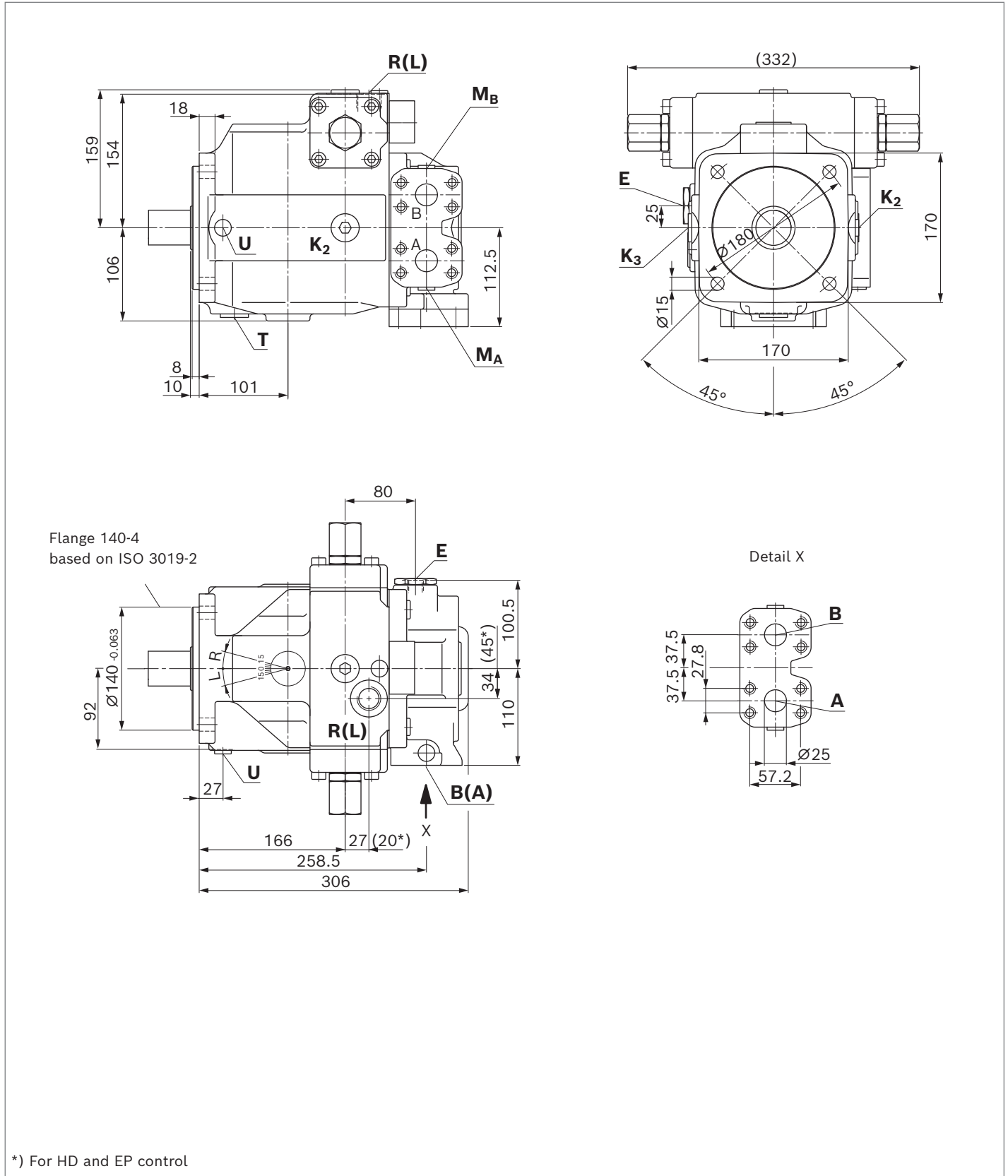

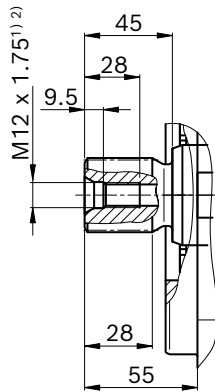
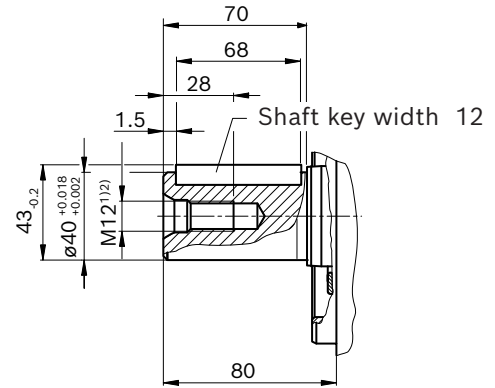

▼ **Splined shaft DIN 5480****Z** – W40x2x18x9g▼ **Parallel keyed shaft DIN 6885****P** – AS12x8x68

Ports	Standard	Size	$p_{max}$ [bar] <sup>(3)</sup>	State <sup>(7)</sup>	
<b>A, B</b>	Working port (high-pressure series) Fastening thread	SAE J518 <sup>(4)</sup> DIN 13	1 in M12 × 1.75; 17 deep	400	O
<b>M<sub>A</sub>, M<sub>B</sub></b>	Measuring working pressure <b>A/B</b>	DIN 3852	M14 × 1.5; 12 deep	400	X
<b>T</b>	Fluid drain	DIN 3852 <sup>(5)</sup>	M27 × 2; 16 deep	5	X <sup>(6)</sup>
<b>E</b>	Boost pressure supply	DIN 3852	M18 × 1.5; 12 deep	50	O
<b>K<sub>2</sub>, K<sub>3</sub></b>	Filling – air bleeding, return flow (drain port)	DIN 3852 <sup>(5)</sup>	M27 × 2; 16 deep	5	X <sup>(6)</sup>
<b>R(L)</b>	Filling – air bleeding, return flow (drain port)	DIN 3852 <sup>(5)</sup>	M27 × 2; 16 deep	5	O <sup>(6)</sup>
<b>U</b>	Bearing flushing	DIN 3852 <sup>(5)</sup>	M14 × 1.5; 12 deep	7	X

1) Center bore according to DIN 332

2) Thread according to DIN 13

3) Depending on the application, momentary pressure peaks can occur.  
Keep this in mind when selecting measuring devices and fittings.

4) Metric fastening thread is a deviation from standard.

5) The countersink may be deeper than specified in the standard.

6) Depending on the installation position **T**, **K<sub>1</sub>**, **K<sub>2</sub>** or **R(L)** must be connected (see also installation instructions on pages 51 to 53).

7) O = Must be connected (plugged on delivery)

X = Plugged (in normal operation)

### Dimensions, size 125

Example: **HM – Hydraulic control, control volume dependent**, for additional dimensions, see data sheets for the controls

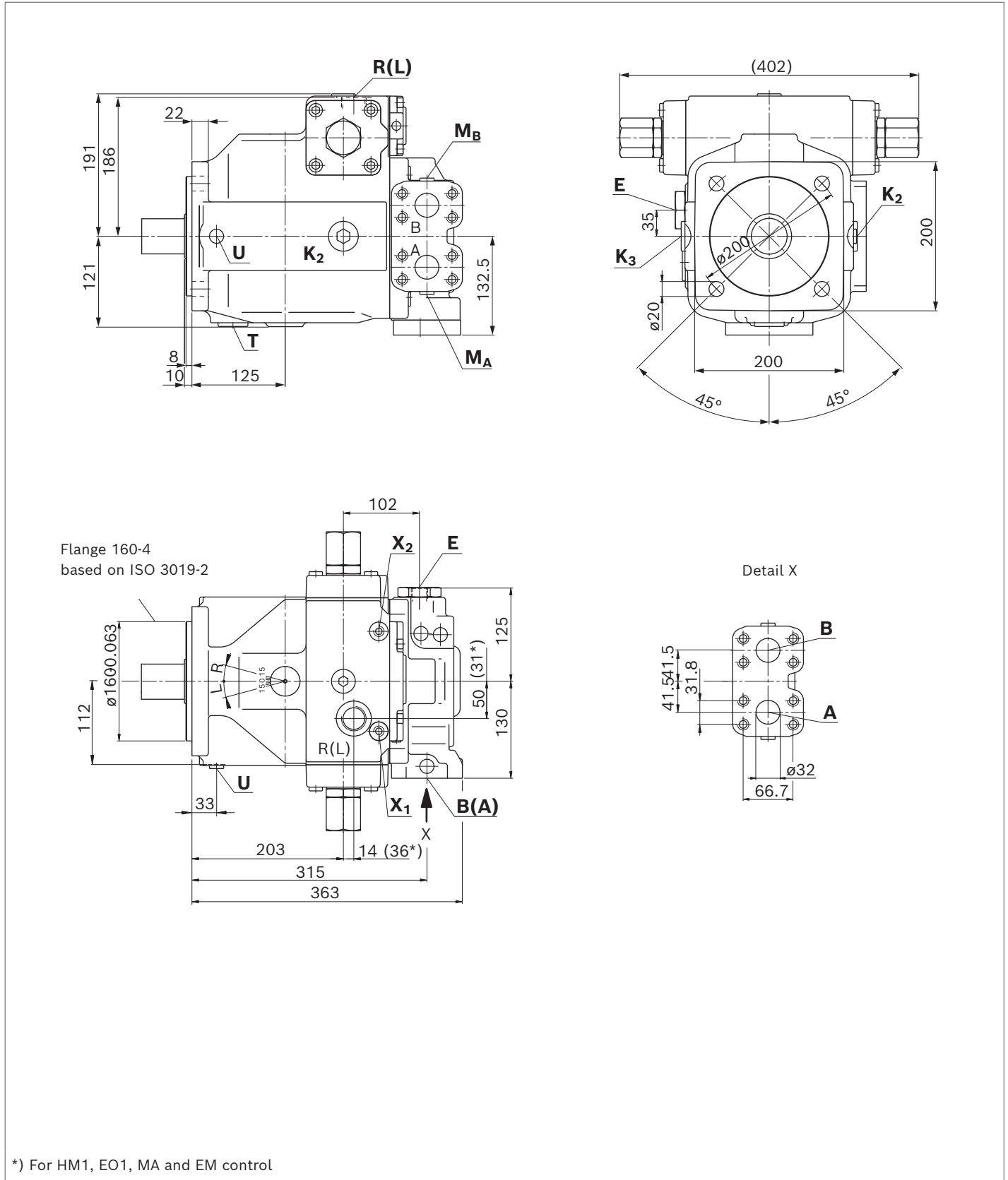

▼ **Splined shaft DIN 5480**

Z – W50x2x24x9g

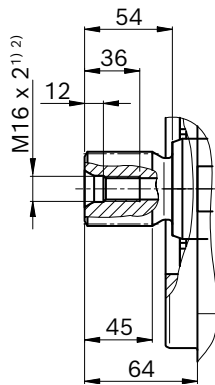
▼ **Parallel keyed shaft DIN 6885**

P – AS14x9x80

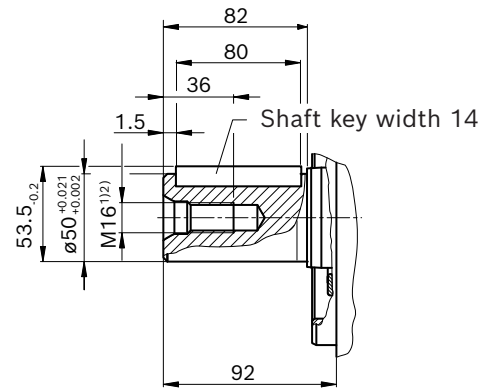

Ports		Standard	Size	$p_{max}$ [bar] <sup>3)</sup>	State <sup>7)</sup>
<b>A, B</b>	Working port (high-pressure series) Fastening thread	SAE J518 <sup>4)</sup> DIN 13	1 1/4 in M14 × 2; 19 deep	400	O
<b>M<sub>A</sub>, M<sub>B</sub></b>	Measuring working pressure <b>A/B</b>	DIN 3852	M14 × 1.5; 12 deep	400	X
<b>T</b>	Fluid drain	DIN 3852 <sup>5)</sup>	M33 × 2; 18 deep	5	X <sup>6)</sup>
<b>E</b>	Boost pressure supply	DIN 3852	M22 × 1.5; 14 deep	50	O
<b>X<sub>1</sub>, X<sub>2</sub></b>	Control pressure (for HM1)	DIN 3852	M14 × 1.5; 12 deep	100	O
<b>X<sub>1</sub>, X<sub>2</sub></b>	Control pressure (for HM2)	DIN 3852	M18 × 1.5; 12 deep	350	O
<b>K<sub>2</sub>, K<sub>3</sub></b>	Filling – air bleeding, return flow (drain port)	DIN 3852 <sup>5)</sup>	M33 × 2; 18 deep	5	X <sup>6)</sup>
<b>R(L)</b>	Filling – air bleeding, return flow (drain port)	DIN 3852 <sup>5)</sup>	M33 × 2; 18 deep	5	O <sup>6)</sup>
<b>U</b>	Bearing flushing	DIN 3852 <sup>5)</sup>	M14 × 1.5; 12 deep	7	X

1) Center bore according to DIN 332

2) Thread according to DIN 13

3) Depending on the application, momentary pressure peaks can occur.  
Keep this in mind when selecting measuring devices and fittings.

4) Metric fastening thread is a deviation from standard.

5) The countersink may be deeper than specified in the standard.

6) Depending on the installation position **T**, **K<sub>1</sub>**, **K<sub>2</sub>** or **R(L)** must be connected (see also installation instructions on pages 51 to 53).

7) O = Must be connected (plugged on delivery)

X = Plugged (in normal operation)

**Dimensions, size 180**

Example: **HM – Hydraulic control, control volume dependent**, for additional dimensions, see data sheets for the controls

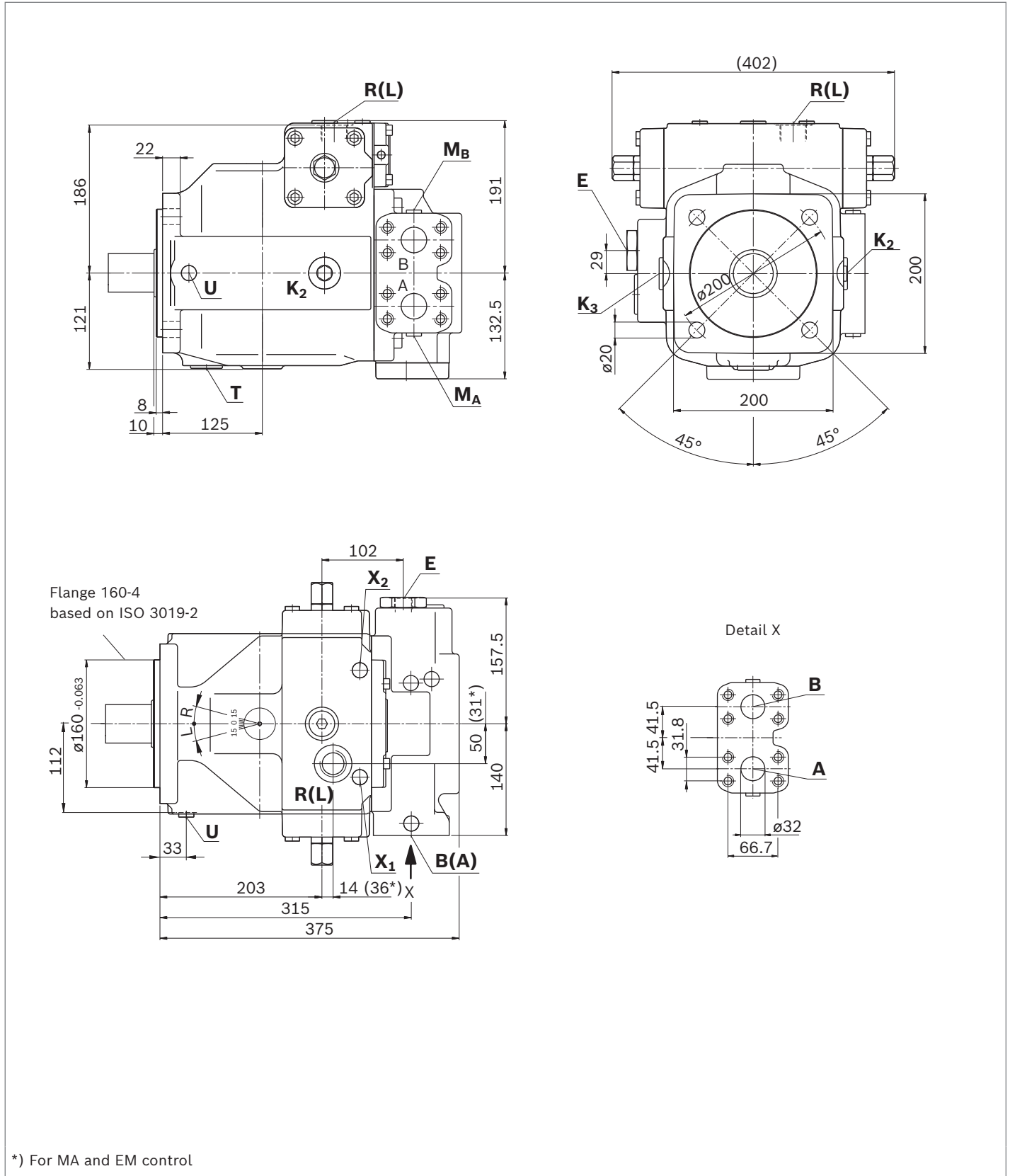

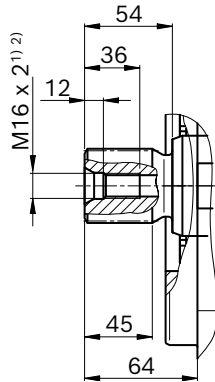
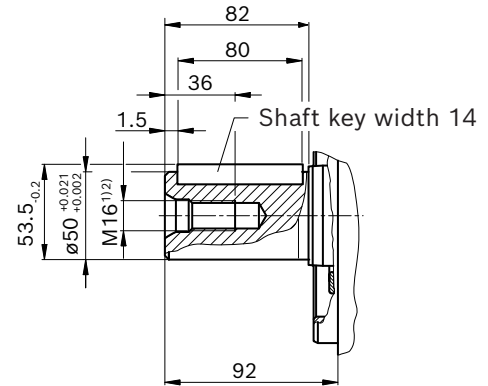
▼ **Splined shaft DIN 5480****Z** – W50x2x24x9g▼ **Parallel keyed shaft DIN 6885****P** – AS14x9x80

Ports		Standard	Size	$p_{\max}$ [bar] <sup>3)</sup>	State <sup>7)</sup>
<b>A, B</b>	Working port (high-pressure series) Fastening thread	SAE J518 <sup>4)</sup> DIN 13	1 1/4 in M14 × 2; 19 deep	400	O
<b>M<sub>A</sub>, M<sub>B</sub></b>	Measuring working pressure <b>A/B</b>	DIN 3852	M14 × 1.5; 12 deep	400	X
<b>T</b>	Fluid drain	DIN 3852 <sup>5)</sup>	M33 × 2; 18 deep	5	X <sup>6)</sup>
<b>E</b>	Boost pressure supply	DIN 3852	M22 × 1.5; 14 deep	50	O
<b>X<sub>1</sub>, X<sub>2</sub></b>	Control pressure (for HM1)	DIN 3852	M14 × 1.5; 12 deep	100	O
<b>X<sub>1</sub>, X<sub>2</sub></b>	Control pressure (for HM2)	DIN 3852	M18 × 1.5; 12 deep	350	O
<b>K<sub>2</sub>, K<sub>3</sub></b>	Filling – air bleeding, return flow (drain port)	DIN 3852 <sup>5)</sup>	M33 × 2; 18 deep	5	X <sup>6)</sup>
<b>R(L)</b>	Filling – air bleeding, return flow (drain port)	DIN 3852 <sup>5)</sup>	M33 × 2; 18 deep	5	O <sup>6)</sup>
<b>U</b>	Bearing flushing	DIN 3852 <sup>5)</sup>	M14 × 1.5; 12 deep	7	X

1) Center bore according to DIN 332

2) Thread according to DIN 13

3) Depending on the application, momentary pressure peaks can occur. Keep this in mind when selecting measuring devices and fittings.

4) Metric fastening thread is a deviation from standard.

5) The countersink may be deeper than specified in the standard.

6) Depending on the installation position **T**, **K<sub>1</sub>**, **K<sub>2</sub>** or **R(L)** must be connected (see also installation instructions on pages 51 to 53).

7) O = Must be connected (plugged on delivery)

X = Plugged (in normal operation)

**Dimensions, size 250**

Example: **HM – Hydraulic control, control volume dependent**, for additional dimensions, see data sheets for the controls

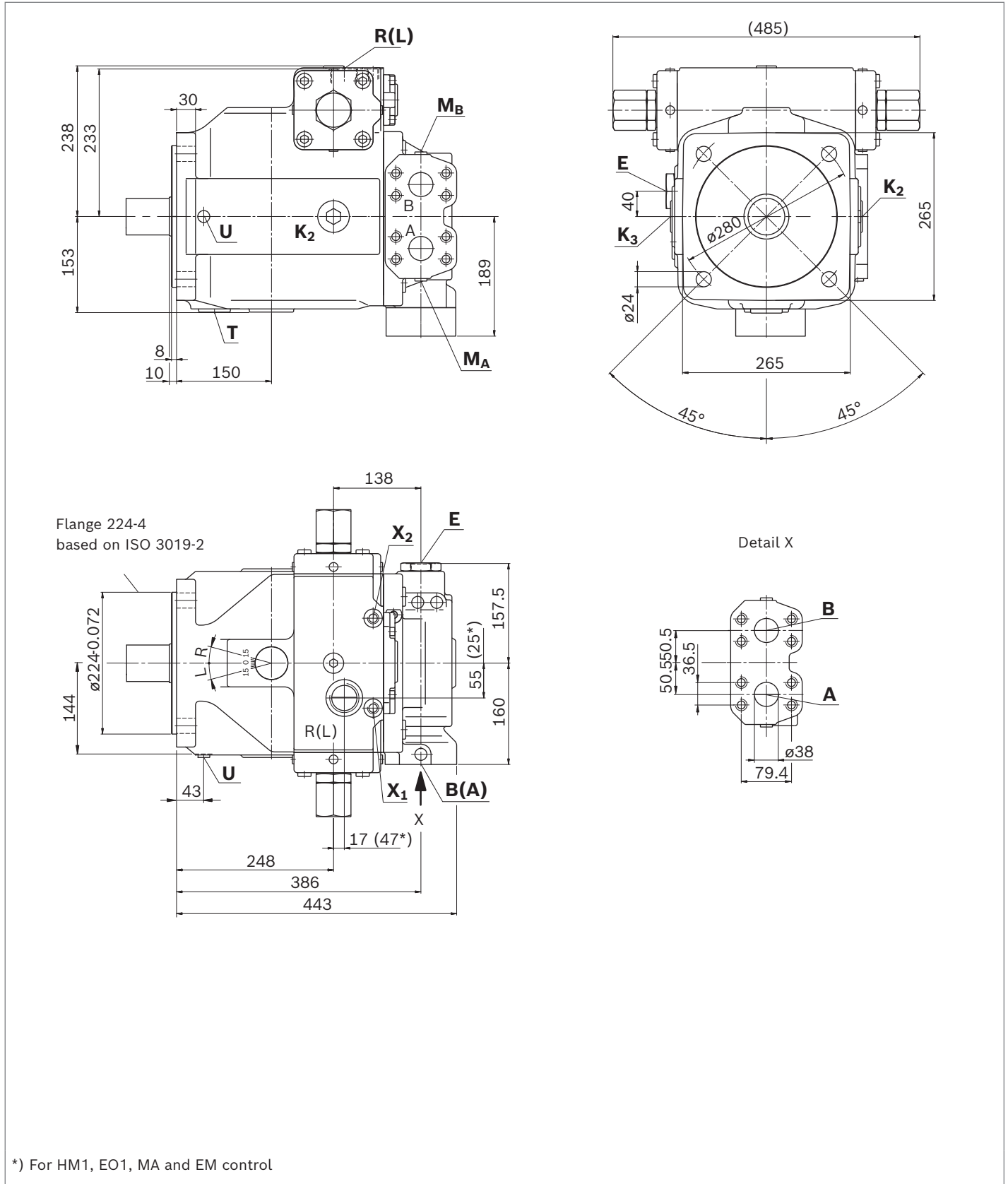

▼ **Splined shaft DIN 5480**

Z – W60x2x28x9g

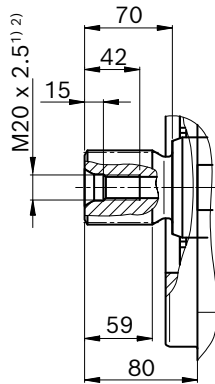
▼ **Parallel keyed shaft DIN 6885**

P – AS18x11x100

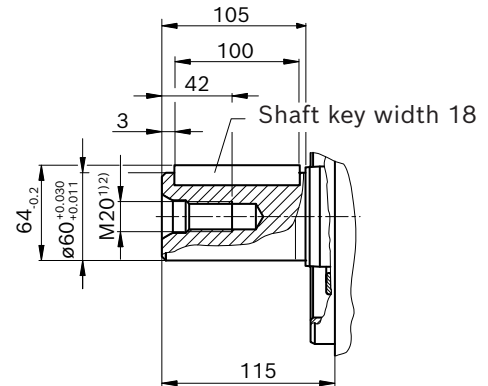

Ports		Standard	Size	$p_{\max}$ [bar] <sup>3)</sup>	State <sup>7)</sup>
<b>A, B</b>	Working port (high-pressure series) Fastening thread	SAE J518 <sup>4)</sup> DIN 13	1 1/2 in M16 × 2; 24 deep	400	O
<b>M<sub>A</sub>, M<sub>B</sub></b>	Measuring working pressure <b>A/B</b>	DIN 3852	M14 × 1.5; 12 deep	400	X
<b>T</b>	Fluid drain	DIN 3852 <sup>5)</sup>	M42 × 2; 20 deep	5	X <sup>6)</sup>
<b>E</b>	Boost pressure supply	DIN 3852	M33 × 2; 18 deep	50	O
<b>X<sub>1</sub>, X<sub>2</sub></b>	Control pressure (for HM1)	DIN 3852	M14 × 1.5; 12 deep	100	O
<b>X<sub>1</sub>, X<sub>2</sub></b>	Control pressure (for HM2)	DIN 3852	M18 × 1.5; 12 deep	350	O
<b>K<sub>2</sub>, K<sub>3</sub></b>	Filling – air bleeding, return flow (drain port)	DIN 3852 <sup>5)</sup>	M42 × 2; 20 deep	5	X <sup>6)</sup>
<b>R(L)</b>	Filling – air bleeding, return flow (drain port)	DIN 3852 <sup>5)</sup>	M42 × 2; 20 deep	5	O <sup>6)</sup>
<b>U</b>	Bearing flushing	DIN 3852 <sup>5)</sup>	M14 × 1.5; 12 deep	7	X

1) Center bore according to DIN 332

2) Thread according to DIN 13

3) Depending on the application, momentary pressure peaks can occur.  
Keep this in mind when selecting measuring devices and fittings.

4) Metric fastening thread is a deviation from standard.

5) The countersink may be deeper than specified in the standard.

6) Depending on the installation position **T**, **K<sub>1</sub>**, **K<sub>2</sub>** or **R(L)** must be connected (see also installation instructions on pages 51 to 53).

7) O = Must be connected (plugged on delivery)

X = Plugged (in normal operation)

**Dimensions, size 355**

Example: **HM – Hydraulic control, control volume dependent**, for additional dimensions, see data sheets for the controls

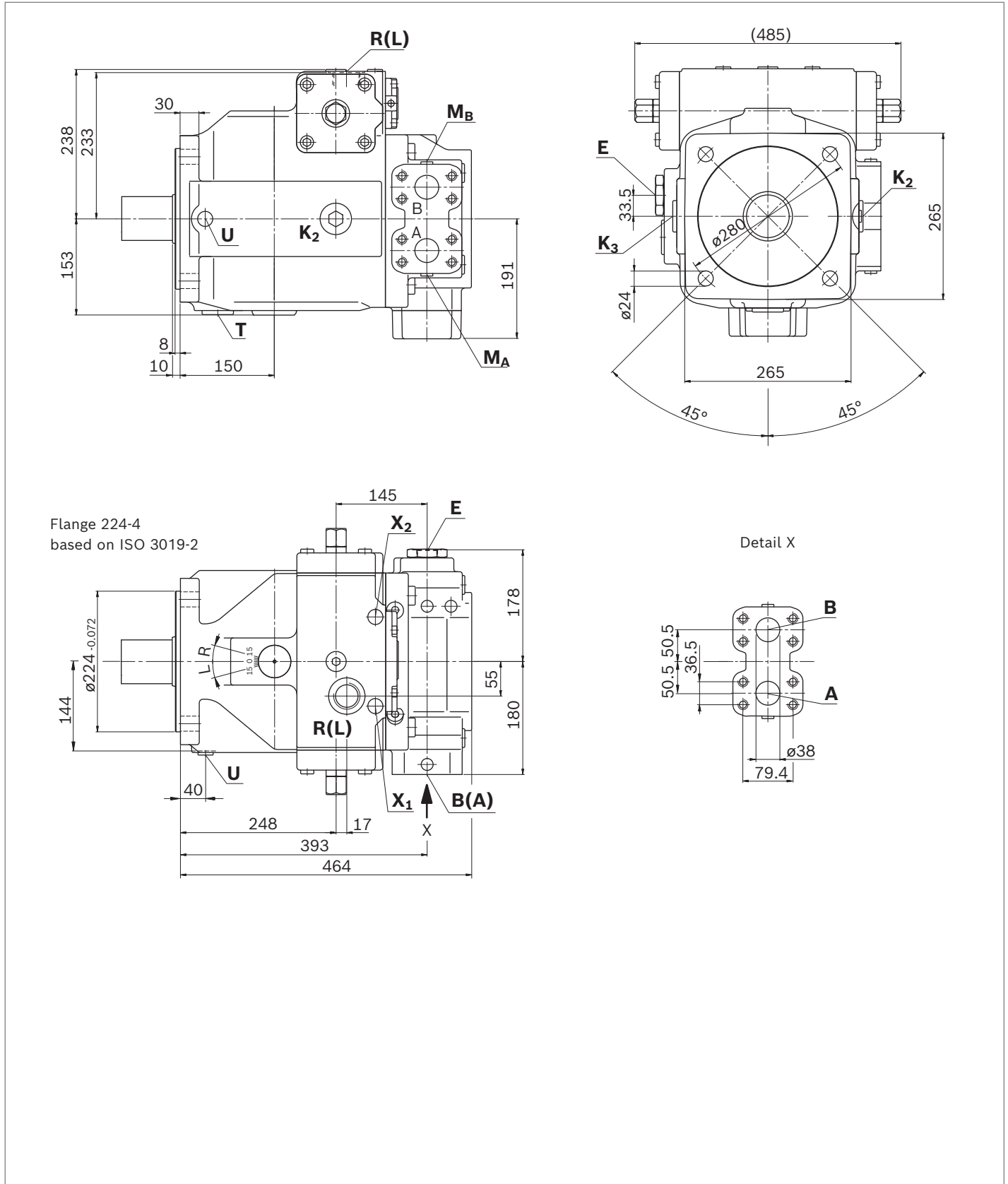

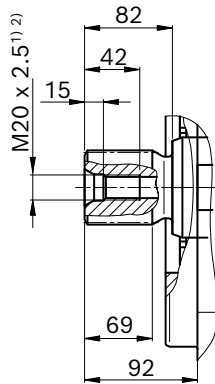
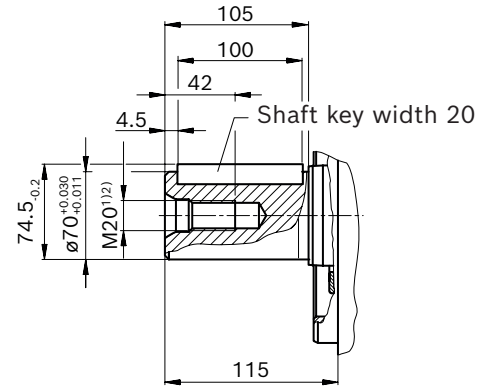

▼ **Splined shaft DIN 5480****Z** – W70x3x22x9g▼ **Parallel keyed shaft DIN 6885****P** – AS20x12x100

Ports	Standard	Size	$p_{max}$ [bar] <sup>3)</sup>	State <sup>7)</sup>	
<b>A, B</b>	Working port (high-pressure series) Fastening thread	SAE J518 <sup>4)</sup> DIN 13	1 1/2 in M16 × 2; 24 deep	400	O
<b>M<sub>A</sub>, M<sub>B</sub></b>	Measuring working pressure <b>A/B</b>	DIN 3852	M14 × 1.5; 12 deep	400	X
<b>T</b>	Fluid drain	DIN 3852 <sup>5)</sup>	M42 × 2; 20 deep	5	X <sup>6)</sup>
<b>E</b>	Boost pressure supply	DIN 3852	M33 × 2; 18 deep	50	O
<b>X<sub>1</sub>, X<sub>2</sub></b>	Control pressure (for HM2)	DIN 3852	M18 × 1.5; 12 deep	350	O
<b>K<sub>2</sub>, K<sub>3</sub></b>	Filling – air bleeding, return flow (drain port)	DIN 3852 <sup>5)</sup>	M42 × 2; 20 deep	5	X <sup>6)</sup>
<b>R(L)</b>	Filling – air bleeding, return flow (drain port)	DIN 3852 <sup>5)</sup>	M42 × 2; 20 deep	5	O <sup>6)</sup>
<b>U</b>	Bearing flushing	DIN 3852 <sup>5)</sup>	M14 × 1.5; 12 deep	7	X

1) Center bore according to DIN 332

2) Thread according to DIN 13

3) Depending on the application, momentary pressure peaks can occur.  
Keep this in mind when selecting measuring devices and fittings.

4) Metric fastening thread is a deviation from standard.

5) The countersink may be deeper than specified in the standard.

6) Depending on the installation position **T**, **K<sub>1</sub>**, **K<sub>2</sub>** or **R(L)** must be connected (see also installation instructions on pages 51 to 53).

7) O = Must be connected (plugged on delivery)

X = Plugged (in normal operation)

**Dimensions, size 500**

Example: **HM – Hydraulic control, control volume dependent**, for additional dimensions, see data sheets for the controls

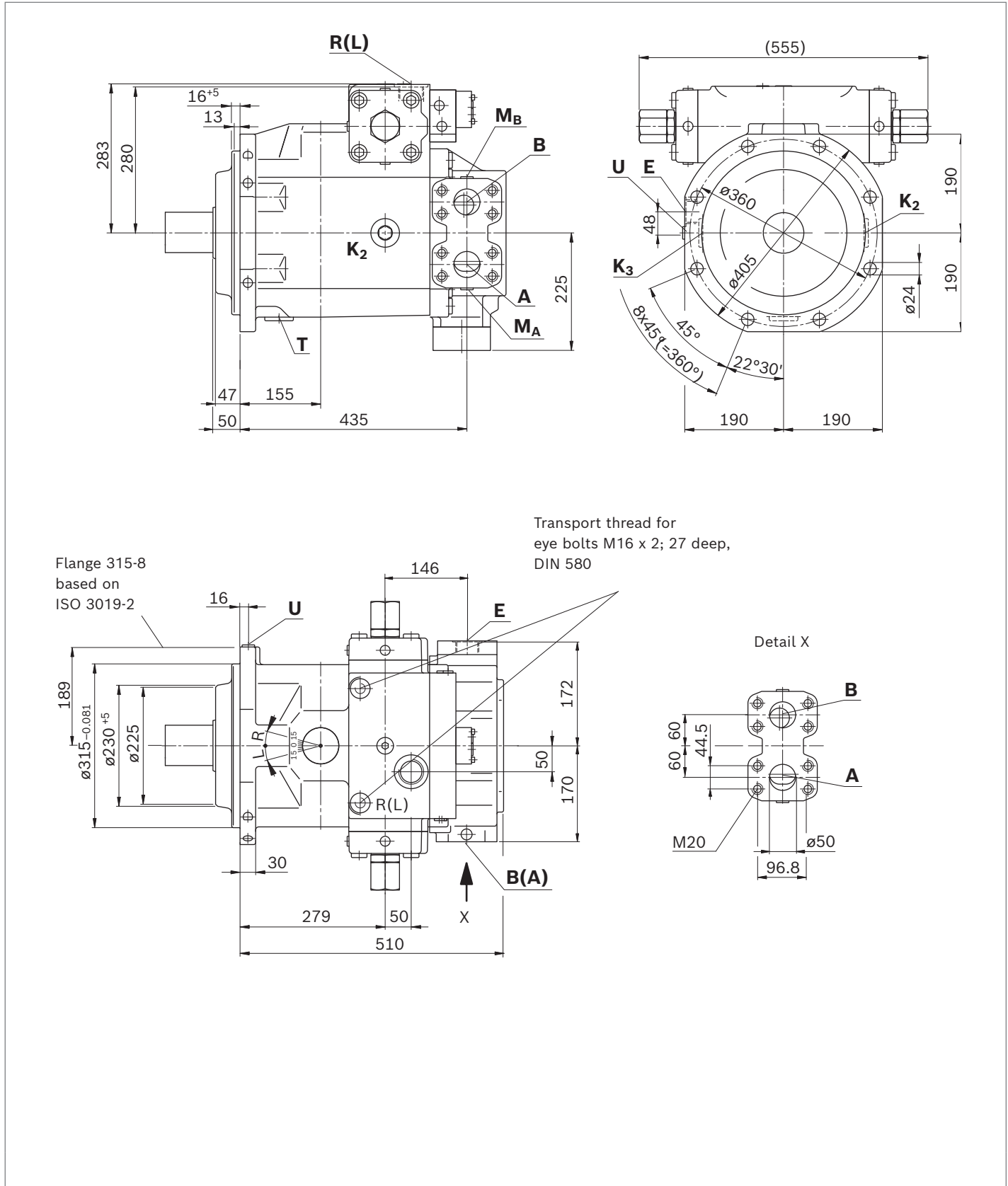

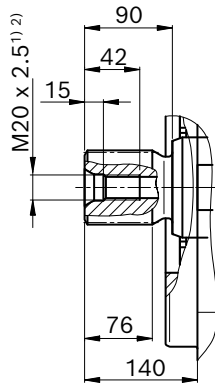
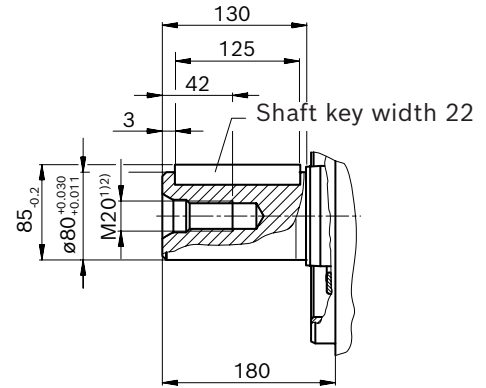
▼ **Splined shaft DIN 5480****Z** – W80x3x25x9g▼ **Parallel keyed shaft DIN 6885****P** – AS22x14x125

Ports	Standard	Size	$p_{max}$ [bar] <sup>(3)</sup>	State <sup>(7)</sup>	
<b>A, B</b>	Working port (high-pressure series) Fastening thread	SAE J518 <sup>(4)</sup> DIN 13	2 in M20 × 2.5; 24 deep	400	O
<b>M<sub>A</sub>, M<sub>B</sub></b>	Measuring working pressure <b>A/B</b>	DIN 3852	M18 × 1.5; 12 deep	400	X
<b>T</b>	Fluid drain	DIN 3852 <sup>(5)</sup>	M48 × 2; 22 deep	5	X <sup>(6)</sup>
<b>E</b>	Boost pressure supply	DIN 3852	M33 × 2; 18 deep	50	O
<b>X<sub>1</sub>, X<sub>2</sub></b>	Control pressure (for HM2)	DIN 3852	M27 × 2; 16 deep	350	O
<b>K<sub>2</sub>, K<sub>3</sub></b>	Filling – air bleeding, return flow (drain port)	DIN 3852 <sup>(5)</sup>	M48 × 2; 22 deep	5	X <sup>(6)</sup>
<b>R(L)</b>	Filling – air bleeding, return flow (drain port)	DIN 3852 <sup>(5)</sup>	M48 × 2; 22 deep	5	O <sup>(6)</sup>
<b>U</b>	Bearing flushing	DIN 3852 <sup>(5)</sup>	M18 × 1.5; 12 deep	7	X

1) Center bore according to DIN 332

2) Thread according to DIN 13

3) Depending on the application, momentary pressure peaks can occur. Keep this in mind when selecting measuring devices and fittings.

4) Metric fastening thread is a deviation from standard.

5) The countersink may be deeper than specified in the standard.

6) Depending on the installation position **T**, **K<sub>1</sub>**, **K<sub>2</sub>** or **R(L)** must be connected (see also installation instructions on pages 51 to 53).

7) O = Must be connected (plugged on delivery)

X = Plugged (in normal operation)

**Dimensions, size 750**

Example: **HM – Hydraulic control, control volume dependent**, for additional dimensions, see data sheets for the controls

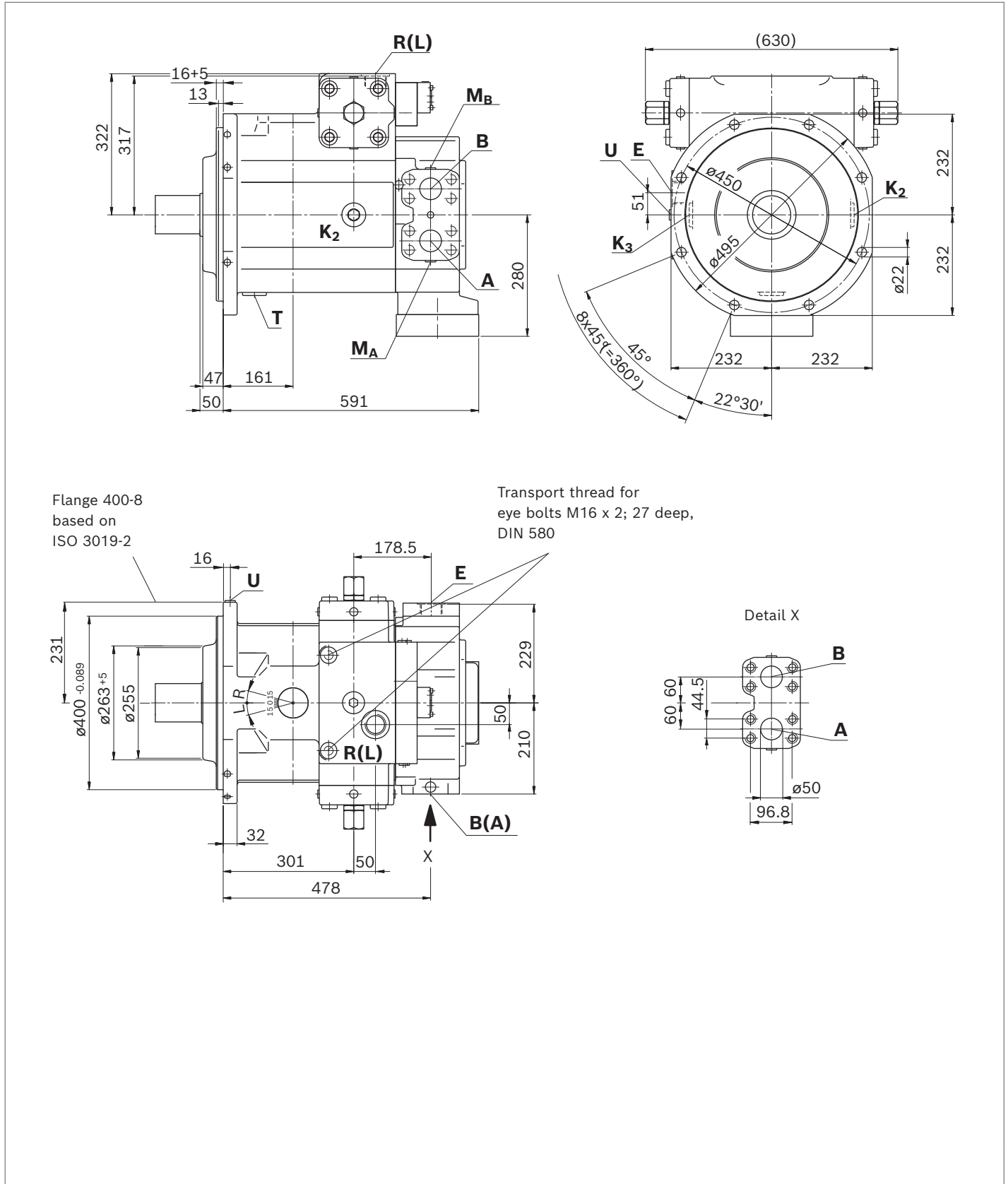

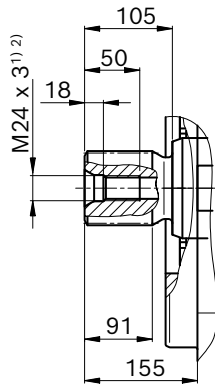
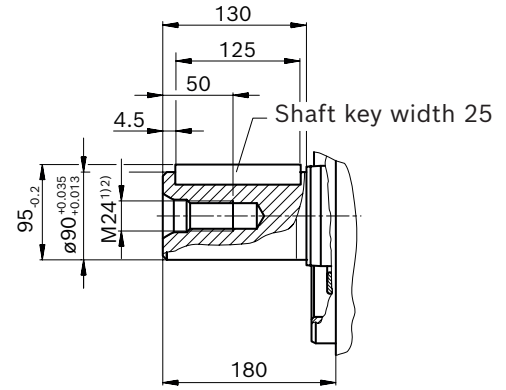
▼ **Splined shaft DIN 5480****Z** – W90x3x28x9g▼ **Parallel keyed shaft DIN 6885****P** – AS25x14x125

Ports		Standard	Size	$p_{\max}$ [bar] <sup>(3)</sup>	State <sup>(7)</sup>
<b>A, B</b>	Working port (high-pressure series) Fastening thread	SAE J518 <sup>(4)</sup> DIN 13	2 in M20 × 2.5; 24 deep	400	O
<b>M<sub>A</sub>, M<sub>B</sub></b>	Measuring working pressure <b>A/B</b>	DIN 3852	M18 × 1.5; 12 deep	400	X
<b>T</b>	Fluid drain	DIN 3852 <sup>(5)</sup>	M48 × 2; 22 deep	5	X <sup>(6)</sup>
<b>E</b>	Boost pressure supply	DIN 3852	M33 × 2; 18 deep	50	O
<b>X<sub>1</sub>, X<sub>2</sub></b>	Control pressure (for HM2)	DIN 3852	M27 × 2; 16 deep	350	O
<b>K<sub>2</sub>, K<sub>3</sub></b>	Filling – air bleeding, return flow (drain port)	DIN 3852 <sup>(5)</sup>	M48 × 2; 22 deep	5	X <sup>(6)</sup>
<b>R(L)</b>	Filling – air bleeding, return flow (drain port)	DIN 3852 <sup>(5)</sup>	M48 × 2; 22 deep	5	O <sup>(6)</sup>
<b>U</b>	Bearing flushing	DIN 3852 <sup>(5)</sup>	M18 × 1.5; 12 deep	7	X

- 1) Center bore according to DIN 332
- 2) Thread according to DIN 13
- 3) Depending on the application, momentary pressure peaks can occur. Keep this in mind when selecting measuring devices and fittings.
- 4) Metric fastening thread is a deviation from standard.

- 5) The countersink may be deeper than specified in the standard.
- 6) Depending on the installation position **T**, **K<sub>1</sub>**, **K<sub>2</sub>** or **R(L)** must be connected (see also installation instructions on pages 51 to 53).
- 7) O = Must be connected (plugged on delivery)  
X = Plugged (in normal operation)

### Dimensions size 1000

Example: **HM - Hydraulic control, control volume dependent**, for additional dimensions, see data sheets for the controls

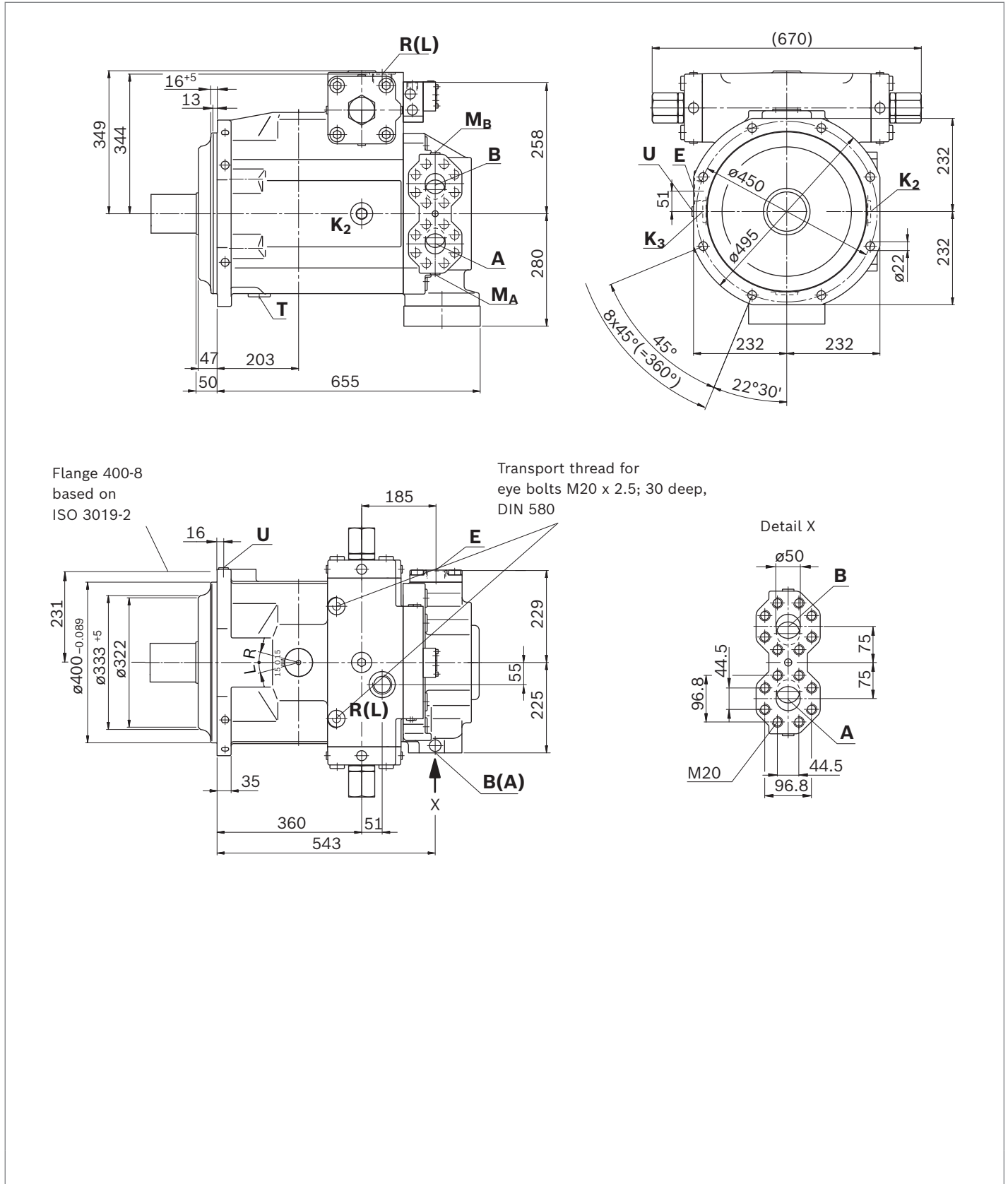

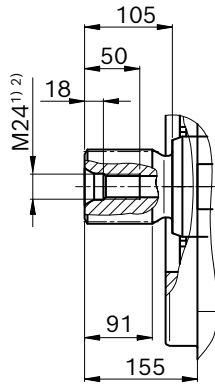
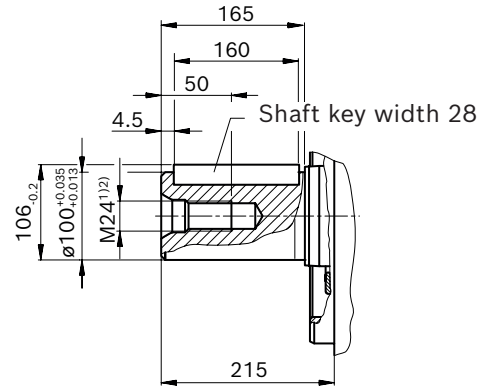
▼ **Splined shaft DIN 5480****Z** – W100x3x32x9g▼ **Parallel keyed shaft DIN 6885****P** – AS28x16x160

Ports		Standard	Size	$p_{\max}$ [bar] <sup>3)</sup>	State <sup>7)</sup>
<b>A, B</b>	Working port (high-pressure series) Fastening thread	SAE J518 <sup>4)</sup> DIN 13	2 in M20 × 2.5; 30 deep	400	O
<b>M<sub>A</sub>, M<sub>B</sub></b>	Measuring working pressure <b>A/B</b>	DIN 3852	M18 × 1.5; 12 deep	400	X
<b>T</b>	Fluid drain	DIN 3852 <sup>5)</sup>	M48 × 2; 22 deep	5	X <sup>6)</sup>
<b>E</b>	Boost pressure supply	DIN 3852	M48 × 2; 20 deep	50	O
<b>K<sub>2</sub>, K<sub>3</sub></b>	Filling – air bleeding, return flow (drain port)	DIN 3852 <sup>5)</sup>	M48 × 2; 22 deep	5	X <sup>6)</sup>
<b>R(L)</b>	Filling – air bleeding, return flow (drain port)	DIN 3852 <sup>5)</sup>	M48 × 2; 22 deep	5	O <sup>6)</sup>
<b>U</b>	Bearing flushing	DIN 3852 <sup>5)</sup>	M18 × 1.5; 12 deep	7	X

- 1) Center bore according to DIN 332
- 2) Thread according to DIN 13
- 3) Depending on the application, momentary pressure peaks can occur. Keep this in mind when selecting measuring devices and fittings.
- 4) Metric fastening thread is a deviation from standard.

- 5) The countersink may be deeper than specified in the standard.
- 6) Depending on the installation position **T**, **K<sub>1</sub>**, **K<sub>2</sub>** or **R(L)** must be connected (see also installation instructions on pages 51 to 53).
- 7) O = Must be connected (plugged on delivery)  
X = Plugged (in normal operation)

## Dimensions for through drives

Flange ISO 3019-2 (metric)		Hub for splined shaft <sup>1)</sup>	Availability across sizes									Code	
Diameter	Mounting <sup>2)</sup>		Diameter	40	71	125	180	250	355	500	750		1000
125-4		N32 × 2 × 14 × 8H	●	●	●	●	●	●	○	●	○	○	K31
140-4		N40 × 2 × 18 × 8H	-	●	●	●	●	●	●	●	○	●	K33

● = Available    ○ = On request    - = Not available

### ▼ 125-4

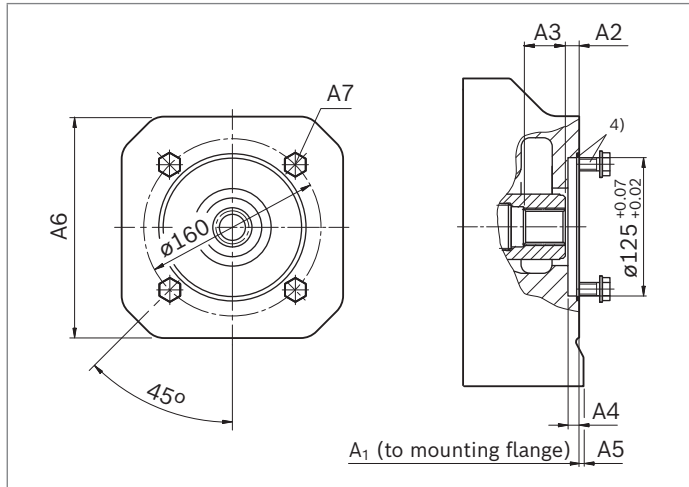

K31							
NG	A1	A2	A3	A4	A5	A6	A7 <sup>3)5)</sup>
40	288	12.5	41.4	9.5	-	-	M12; 25 deep
71	316	12.5	33.6	10	-	-	M12; 25 deep
125	373	12.5	42	9.5	-	-	M12; 25 deep
180	397	12.5	42	9.5	-	-	M12; 25 deep
250	431	12.5	37.9	10	10	200	M12; 18 deep
500	505	12.5	38.5	10	-	-	M12; 18 deep

### ▼ 140-4

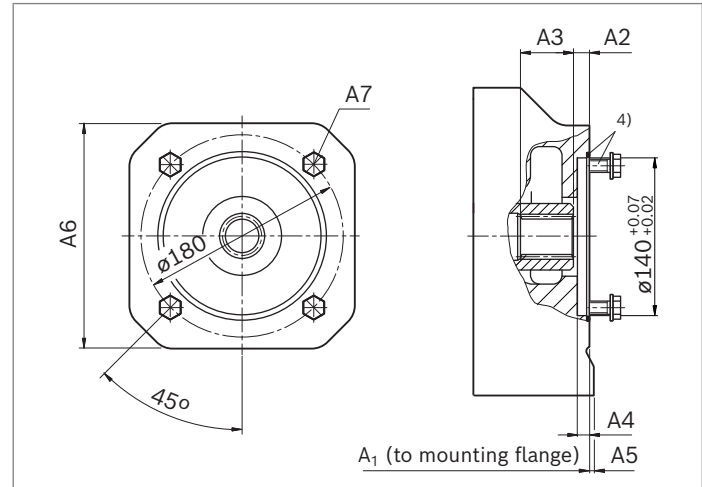

K33							
NG	A1	A2	A3	A4	A5	A6	A7 <sup>3)5)</sup>
71	316	11.5	44	9	-	-	M12; 25 deep
125	373	12.5	50	9.5	-	-	M12; 25 deep
180	397	12.5	43.8	9.5	-	-	M12; 25 deep
250	431	12.5	49	10	10	200	M12; 18 deep
355	460	12.5	49	10	-	-	M12; 18 deep
500	505	12.5	44	10	-	-	M12; 18 deep
1000	628	12.5	64.5	10	27	280	M12; 18 deep

1) According to DIN 5480

2) Mounting holes pattern viewed on through drive with control at top

3) Thread according to DIN 13; observe the maximum tightening torques in the instruction manual.

4) O-ring and mounting bolts included in delivery.

5) Design recommended according to VDI 2230, bolt grade 8.8 according to ISO 898-1



### Dimensions for through drives

Flange ISO 3019-2 (metric)		Hub for splined shaft <sup>1)</sup>	Availability across sizes								Code	
Diameter	Mounting <sup>2)</sup>		Diameter	40	71	125	180	250	355	500		750
160-4		N50 × 2 × 24 × 8H	-	-	●	●	●	●	●	○	●	K34
224-4		N60 × 2 × 28 × 8H	-	-	-	-	●	●	●	●	●	K35

● = Available    ○ = On request    - = Not available

▼ **160-4**

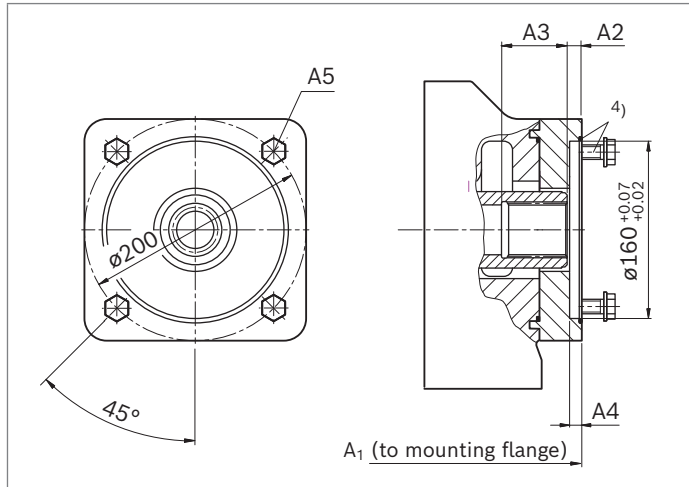

K34					
NG	A1	A2	A3	A4	A5 <sup>3)5)</sup>
125	379	12.5	58	10	M16; 30 deep
180	403	12.5	58	10	M16; 30 deep
250	469	12.5	60	10	M16; 32 deep
355	498	12.5	60	10	M16; 32 deep
500	505	13.5	55	10	M16; 24 deep
1000	628	12.5	55	10	M16; 24 deep

▼ **224-4**

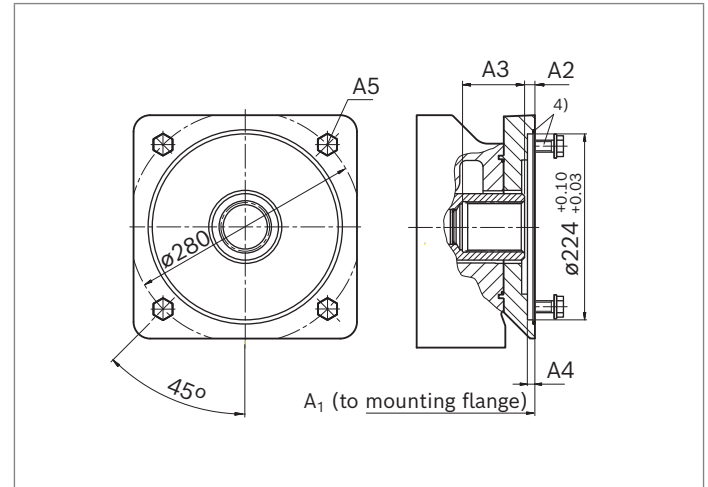

K35					
NG	A1	A2	A3	A4	A5 <sup>3)5)</sup>
250	469	12.5	75	9	M20; 36 deep
355	498	12.5	75	9	M20; 36 deep
500	541	12.5	74	9	M20; 36 deep
750	591	12.5	74	9	M20; 36 deep
1000	664	12.5	69.5	9	M20; 36 deep

1) According to DIN 5480  
 2) Mounting holes pattern viewed on through drive with control at top  
 3) Thread according to DIN 13; observe the maximum tightening torques in the instruction manual.

4) O-ring and mounting bolts included in delivery.  
 5) Design recommended according to VDI 2230, bolt grade 8.8 according to ISO 898-1

## Dimensions for through drives

Flange ISO 3019-2 (metric)		Hub for splined shaft <sup>1)</sup>	Availability across sizes									Code
Diameter	Mounting <sup>2)</sup>		40	71	125	180	250	355	500	750	1000	
224-4		N70 × 3 × 22 × 8H	-	-	-	-	-	•	•	○	•	K77
315-8		N80 × 3 × 25 × 8H	-	-	-	-	-	-	•	•	•	K43

• = Available    ○ = On request    - = Not available

### ▼ 224-4

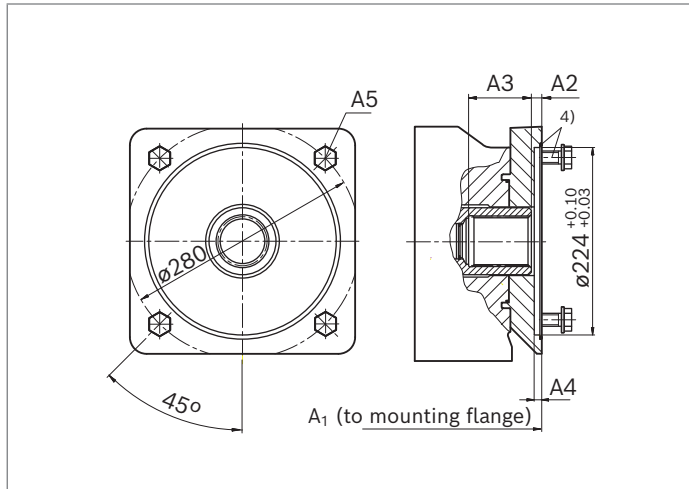

K77					
NG	A1	A2	A3	A4	A5 <sup>3)5)</sup>
355	498	12.5	82	9	M20; 36 deep
500	541	12.5	82	9	M20; 36 deep
1000	664	12.5	82	9	M20; 36 deep

### ▼ 315-8

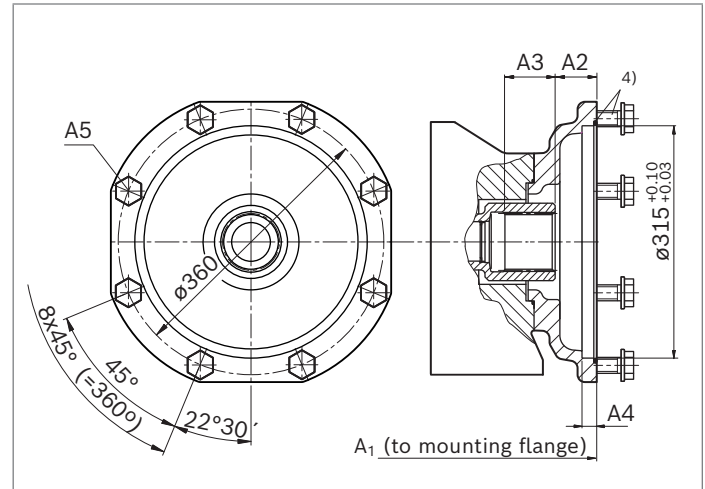

K43					
NG	A1	A2	A3	A4	A5 <sup>3)5)</sup>
500	590	53.5	71.9	19	M20; 26 deep
750	640	53.5	71.9	19	M20; 26 deep
1000	713	53.5	71	19	M20; 26 deep

1) According to DIN 5480

2) Mounting holes pattern viewed on through drive with control at top

3) Thread according to DIN 13; observe the maximum tightening torques in the instruction manual.

4) O-ring and mounting bolts included in delivery.

5) Design recommended according to VDI 2230, bolt grade 8.8 according to ISO 898-1

### Dimensions for through drives

Flange ISO 3019-2 (metric)		Hub for splined shaft <sup>1)</sup>	Availability across sizes									Code
Diameter	Mounting <sup>2)</sup>	Diameter	40	71	125	180	250	355	500	750	1000	
400-8		N90 × 3 × 28 × 8H	-	-	-	-	-	-	-	•	•	K76
400-8		N100 × 3 × 32 × 8H	-	-	-	-	-	-	-	-	•	K88

• = Available    ◦ = On request    - = Not available

▼ **400-8**

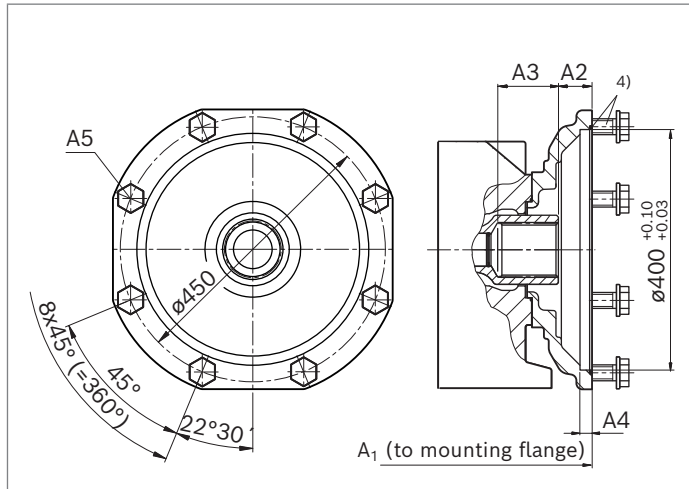

<b>K76</b>						
NG	A1	A2	A3	A4	A5 <sup>3)5)</sup>	
750	655	53	104	19	M20; 26 deep	
1000	728	53	97	19	M20; 26 deep	

▼ **400-8**

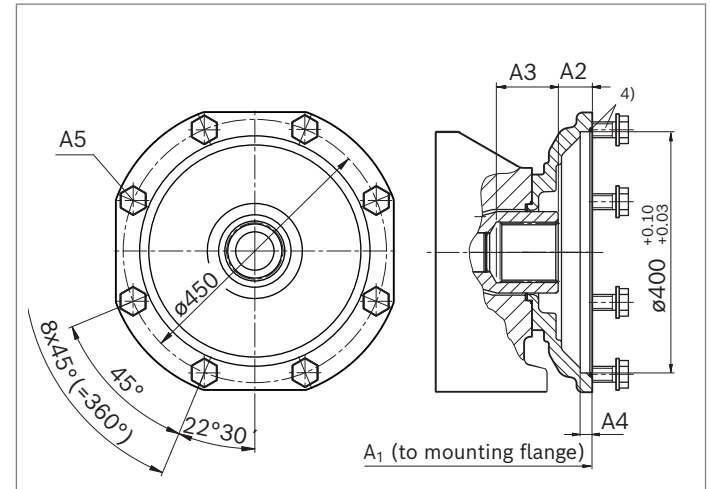

<b>K88</b>						
NG	A1	A2	A3	A4	A5 <sup>3)5)</sup>	
1000	728	53	99	19	M20; 26 deep	

1) According to DIN 5480  
 2) Mounting holes pattern viewed on through drive with control at top  
 3) Thread according to DIN 13; observe the maximum tightening torques in the instruction manual.

4) O-ring and mounting bolts included in delivery.  
 5) Design recommended according to VDI 2230, bolt grade 8.8 according to ISO 898-1

## Dimensions for through drives

Flange ISO 3019-2 (metric)		Hub for splined shaft <sup>1)</sup>		Availability across sizes									Code
Diameter	Mounting <sup>2)</sup>	Diameter		40	71	125	180	250	355	500	750	1000	
80-2		3/4in	11T 16/32DP	○	●	●	○	○	○	○	○	○	KB2

● = Available    ○ = On request    - = Not available

### ▼ 80-2

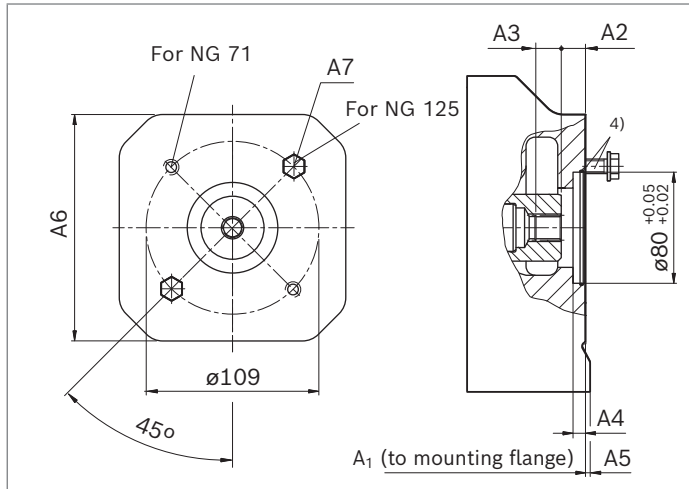

KB2							
NG	A1	A2	A3	A4	A5	A6	A7 <sup>3)5)</sup>
71	291	21.5	19	10	15	140	M10; 15 deep
125	379	24.2	20.5	10	-	-	M10; 12 deep

1) In accordance with ANSI B92.1a, 30° pressure angle, flat root, side fit, tolerance class 5  
 2) Mounting holes pattern viewed on through drive with control at top  
 3) Thread according to DIN 13; observe the maximum tightening torques in the instruction manual.

4) O-ring and mounting bolts included in delivery.  
 5) Design recommended according to VDI 2230, bolt grade 8.8 according to ISO 898-1

### Dimensions for through drives

Flange ISO 3019-2 (metric)		Hub for splined shaft <sup>1)</sup>		Availability across sizes									Code
Diameter	Mounting <sup>2)</sup>	Diameter		40	71	125	180	250	355	500	750	1000	
100-2		7/8in	13T 16/32DP	●	●	●	●	●	●	○	○	○	KB3
100-2		1 in	15T 16/32DP	○	●	●	●	●	●	○	○	○	KB4

● = Available    ○ = On request    - = Not available

▼ **100-2**

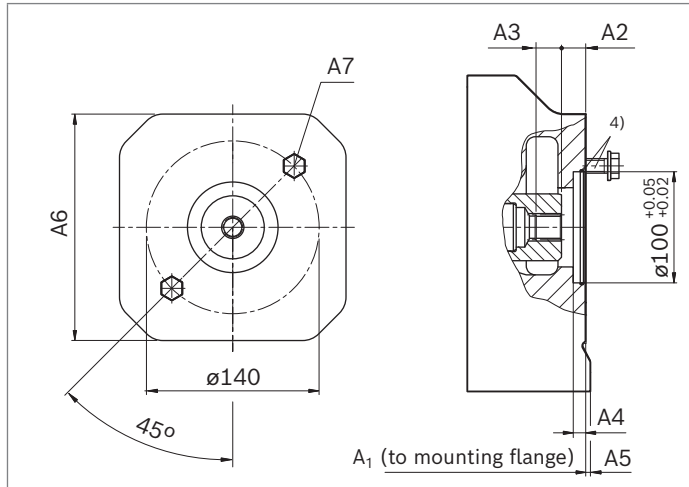

KB3							
NG	A1	A2	A3	A4	A5	A6	A7 <sup>3)5)</sup>
40	290	20.4	23	10	-	-	M12; 18 deep
71	316	20.4	23	9	-	-	M12; 18 deep
125	378	20.3	24.5	10	-	-	M12; 24 deep
180	371	20.5	23	10	-	-	M12; 15 deep
250	431	20.5	23	10	10	200	M12; 18 deep
355	460	20.5	23	10	-	-	M12; 18 deep

▼ **100-2**

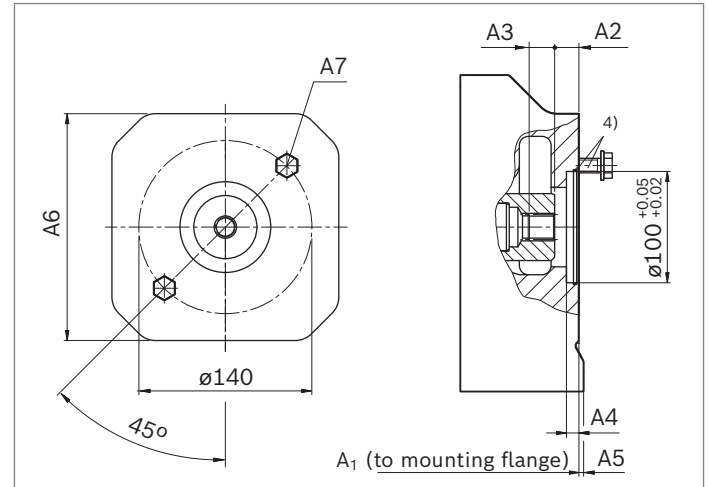

KB4							
NG	A1	A2	A3	A4	A5	A6	A7 <sup>3)5)</sup>
71	316	20.8	27.5	8	-	-	M12; 24 deep
125	378	22.2	29	10	-	-	M12; 24 deep
180	371	21.8	27.9	10	-	-	M12; 15 deep
250	431	20.9	27.5	10	10	200	M12; 18 deep
355	460	20.9	27.5	10	-	-	M12; 18 deep

1) In accordance with ANSI B92.1a, 30° pressure angle, flat root, side fit, tolerance class 5  
 2) Mounting holes pattern viewed on through drive with control at top  
 3) Thread according to DIN 13; observe the maximum tightening torques in the instruction manual.

4) O-ring and mounting bolts included in delivery.  
 5) Design recommended according to VDI 2230, bolt grade 8.8 according to ISO 898-1

## Dimensions for through drives

Flange ISO 3019-2 (metric)		Hub for splined shaft <sup>1)</sup>		Availability across sizes								Code	
Diameter	Mounting <sup>2)</sup>	Diameter		40	71	125	180	250	355	500	750	1000	
125-2		1 1/4in	14T 12/24DP	-	●	●	●	●	●	●	○	○	KB5
125-2		1 1/2in	17T 12/24DP	-	-	●	●	●	●	●	●	○	KB6

● = Available    ○ = On request    - = Not available

### ▼ 125-2

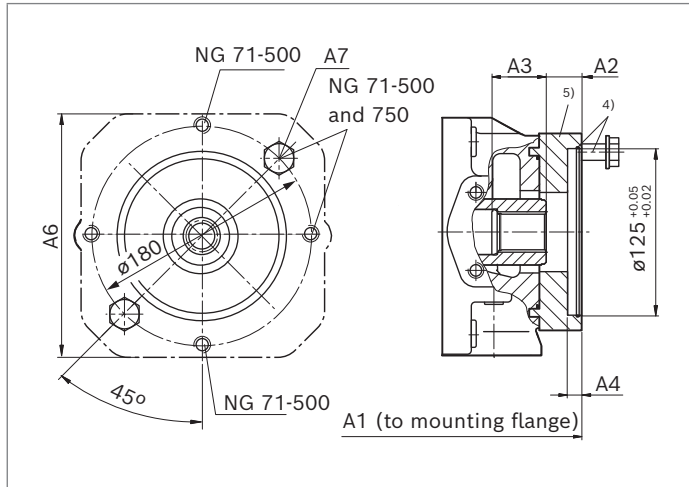

KB5							
NG	A1	A2	A3	A4	A5	A6	A7 <sup>3)7)</sup>
71	321	23.1	38.1	10	-	-	M16; 29 deep
125	378	23.7	38.1	9.5	-	-	M16; 24 deep
180	402	23.7	38.1	9.5	-	-	M16; 24 deep
250	431	22	36.1	10	10	200	M16; 20 deep
355	460	22	36.1	10	-	-	M16; 24 deep
500	505	19.3	40.4	10	-	-	M16; 24 deep

### ▼ 125-2

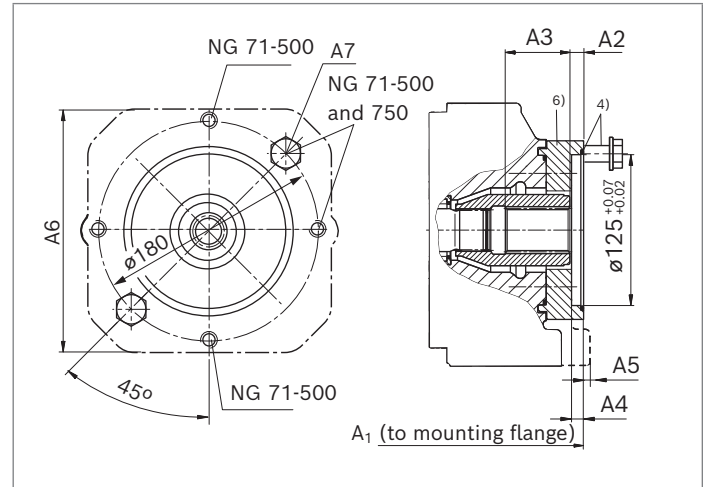

KB6							
NG	A1	A2	A3	A4	A5	A6	A7 <sup>3)7)</sup>
125	378	11.4	54	9.5	-	-	M16; 24 deep
180	402	11.4	54	9.5	-	-	M16; 24 deep
250	451	10.4	55	10	-	-	M16; 20 deep
355	480	10.4	55	10	-	-	M16; 20 deep
500	505	10.3	56	10	-	-	M16; 24 deep
750	555	10.3	56	10	23	250	M16; 24 deep

1) In accordance with ANSI B92.1a, 30° pressure angle, flat root, side fit, tolerance class 5

2) Mounting holes pattern viewed on through drive with control at top

3) Thread according to DIN 13; observe the maximum tightening torques in the instruction manual.

4) O-ring and mounting bolts included in delivery.

5) For 71 to 180 with intermediate plate

6) For 125 to 355 with intermediate plate

7) Design recommended according to VDI 2230, bolt grade 8.8 according to ISO 898-1

**Dimensions for through drives**

Flange ISO 3019-2 (metric)		Hub for splined shaft <sup>1)</sup>		Availability across sizes								Code	
Diameter	Mounting <sup>2)</sup>	Diameter		40	71	125	180	250	355	500	750	1000	
180-4		1 3/4in	13T 8/16DP	-	-	•	•	•	•	•	•	○	KB7

• = Available    ○ = On request    - = Not available

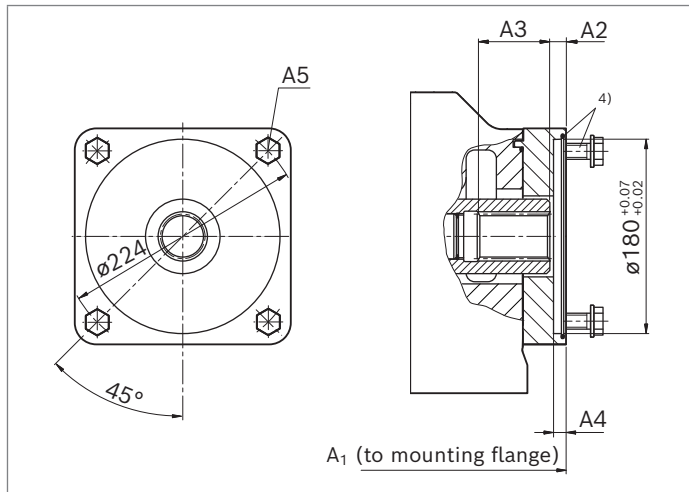
▼ **180-4**

KB7					
NG	A1	A2	A3	A4	A5 <sup>3)5)</sup>
125	395	10.5	45	10	M16; 30 deep
180	419	10.5	45	10	M16; 30 deep
250	469	10.8	67	10	M16; 32 deep
355	498	10.8	67	10	M16; 32 deep
500	530	10.4	63	10	M16; 25 deep
750	580	10.4	63	10	M16; 25 deep

- 1) In accordance with ANSI B92.1a, 30° pressure angle, flat root, side fit, tolerance class 5
- 2) Mounting holes pattern viewed on through drive with control at top
- 3) Thread according to DIN 13; observe the maximum tightening torques in the instruction manual.

- 4) O-ring and mounting bolts included in delivery.
- 5) Design recommended according to VDI 2230, bolt grade 8.8 according to ISO 898-1

## Dimensions for through drives

Flange ISO 3019-1 (SAE J744)		Hub for splined shaft <sup>1)</sup>		Availability across sizes								Code	
Diameter	Mounting <sup>2)</sup>	Diameter		40	71	125	180	250	355	500	750	1000	
82-2 (A)		5/8in 9T 16/32DP		●	●	●	●	●	●	●	●	○	K01
82-2 (A-B)		3/4in 11T 16/32DP		○	●	○	●	○	●	○	○	○	K52

● = Available    ○ = On request

### ▼ 82-2

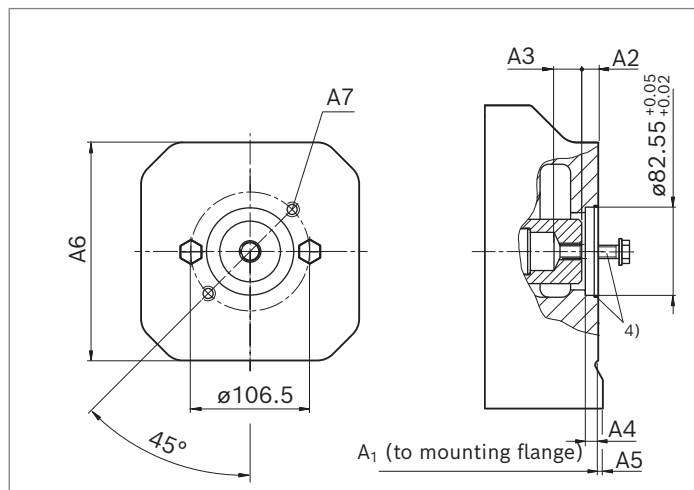

#### K01 (16-4 (A))

NG	A1	A2	A3	A4	A5	A6	A7 <sup>3)5)</sup>
40	263	10.4	25.8	10	18	130	M10; 15 deep
71	291	10.3	25.4	10	15	140	M10; 15 deep
125	347	10.3	28	10	13	150	M10; 15 deep
180	371	10.3	28	10	-	-	M10; 15 deep
250	431	10.5	30	10	10	200	M10; 15 deep
355	460	10.5	30	10	-	-	M10; 15 deep
500	505	10.3	33	10	-	-	M10; 15 deep
750	555	10.3	33	10	-	-	M10; 15 deep

### ▼ 82-2

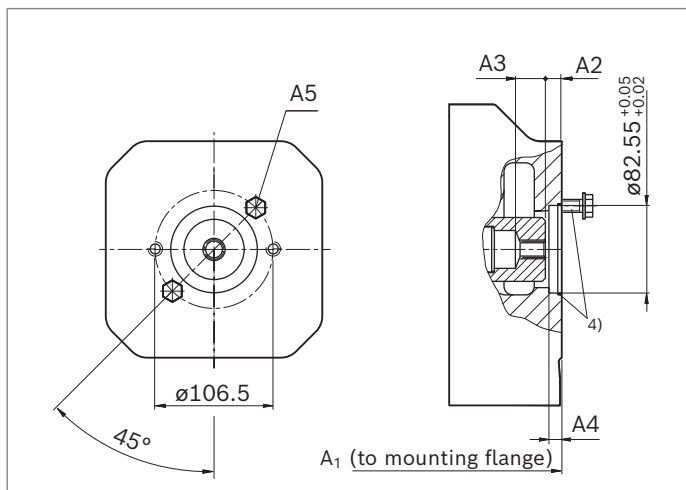

#### K52 (19-4 (A-B))

NG	A1	A2	A3	A4	A5 <sup>3)5)</sup>
71	312	21.5	19	10	M10; 20 deep
180	371	21.4	19.1	10	M10; 15 deep
355	460	21.4	19.1	10	M10; 15 deep

1) In accordance with ANSI B92.1a, 30° pressure angle, flat root, side fit, tolerance class 5

2) Mounting holes pattern viewed on through drive with control at top

3) Thread according to DIN 13; observe the maximum tightening torques in the instruction manual.

4) O-ring and mounting bolts included in delivery.

5) Design recommended according to VDI 2230, bolt grade 8.8 according to ISO 898-1



### Dimensions for through drives

Flange ISO 3019-1 (SAE J744)	Hub for splined shaft <sup>1)</sup>	Availability across sizes										Code		
		Diameter	Mounting <sup>2)</sup>	Diameter	40	71	125	180	250	355	500		750	1000
101-2 (B)	7/8in 13T 16/32DP	•	•	•	•	•	•	•	•	•	•	•	○	K68
101-2 (B-B)	1 in 15T 16/32DP	•	•	•	•	•	•	•	•	•	•	○	○	K04

• = Available    ○ = On request

▼ **101-2**

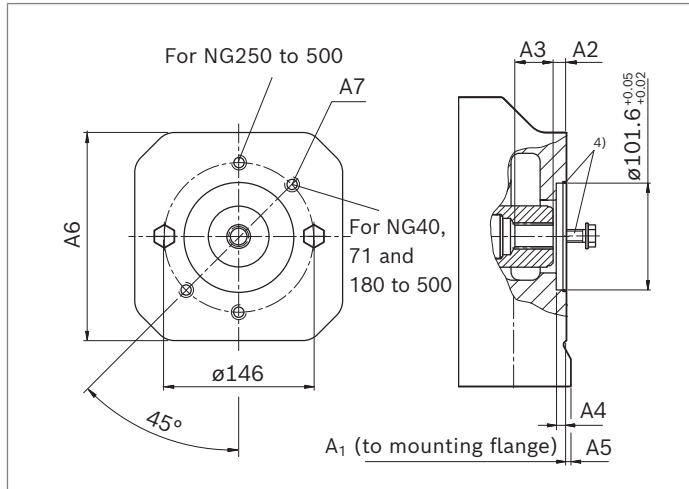

K68 (22-4 (B))							
NG	A1	A2	A3	A4	A5	A6	A7 <sup>3)5)</sup>
40	290	20.4	23.1	10	-	-	M12; 18 deep
71	322	20.5	23.1	10	-	-	M12; 30 deep
125	347	20.5	23.1	10	16	150	M12; 15 deep
180	371	20.5	23.1	10	-	-	M12; 16 deep
250	431	20.5	23.1	10	10	200	M12; 18 deep
355	460	20.5	23.1	10	-	-	M12; 18 deep
500	505	19.5	25	10	-	-	M12; 18 deep
750	555	19.5	25	10	-	-	M12; 18 deep

▼ **101-2**

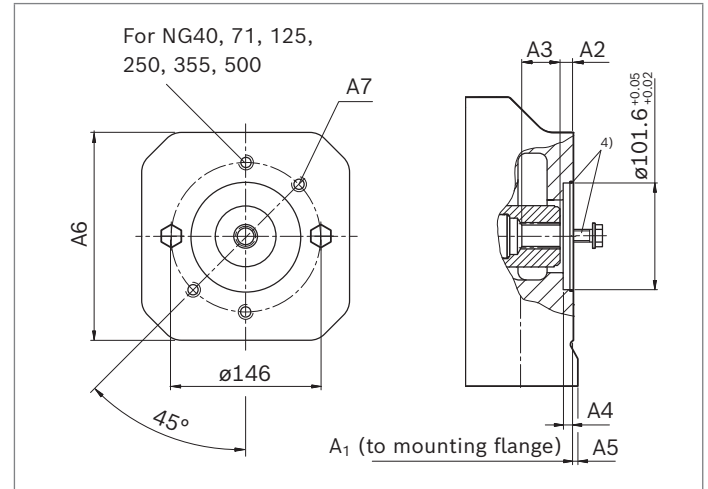

K04 (25-4 (B-B))							
NG	A1	A2	A3	A4	A5	A6	A7 <sup>3)5)</sup>
40	290	20.8	27.5	10	-	-	M12; 20 deep
71	322	20	29.4	10	-	-	M12; 30 deep
125	379	23.7	29	10	-	-	M12; 30 deep
180	371	21.8	27.9	10	-	-	M12; 16 deep
250	431	20.9	27.5	10	10	200	M12; 18 deep
355	460	20.9	27.5	10	-	-	M12; 18 deep
500	505	20.4	28.9	10	-	-	M12; 18 deep

1) In accordance with ANSI B92.1a, 30° pressure angle, flat root, side fit, tolerance class 5  
 2) Mounting holes pattern viewed on through drive with control at top  
 3) Thread according to DIN 13; observe the maximum tightening torques in the instruction manual.

4) O-ring and mounting bolts included in delivery.  
 5) Design recommended according to VDI 2230, bolt grade 8.8 according to ISO 898-1

## Dimensions for through drives

Flange ISO 3019-1 (SAE J744)		Hub for splined shaft <sup>1)</sup>		Availability across sizes								Code	
Diameter	Mounting <sup>2)</sup>	Diameter		40	71	125	180	250	355	500	750	1000	
127-2 (C)		1 1/4in	14T 12/24DP	-	●	●	●	●	●	●	●	●	K07
127-2 (C-C)		1 1/2in	17T 12/24DP	-	-	●	●	●	●	●	●	●	K24

● = Available    ○ = On request    - = Not available

### ▼ 127-2

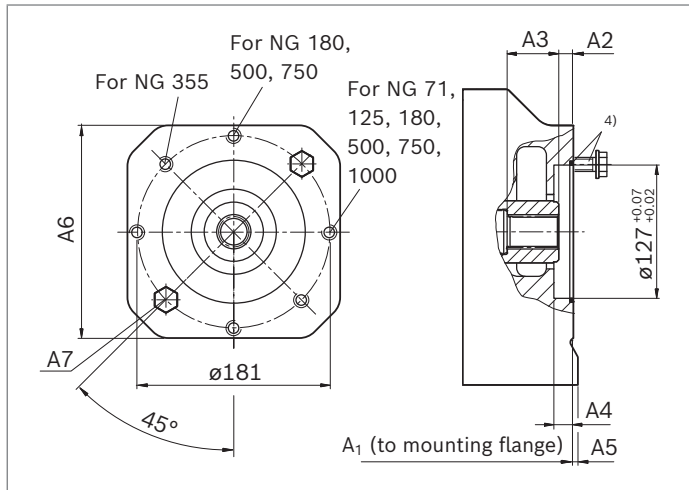

K07 (32-4 (C))							
NG	A1	A2	A3	A4	A5	A6	A7 <sup>3)5)</sup>
71	321	23	38	13	-	-	M16; 30 deep
125	377	22.7	37.5	13	-	-	M16; 28 deep
180	401	22.7	37.5	13	-	-	M16; 28 deep
250	431	22	36	13	10	200	M16; 20 deep
355	460	22	36	13	-	-	M16; 24 deep
500	505	19.3	40.4	13	-	-	M16; 24 deep
750	555	19.3	40.4	13	23	250	M16; 24 deep
1000	628	10.4	54.6	13	25	280	M16; 32 deep

### ▼ 127-2

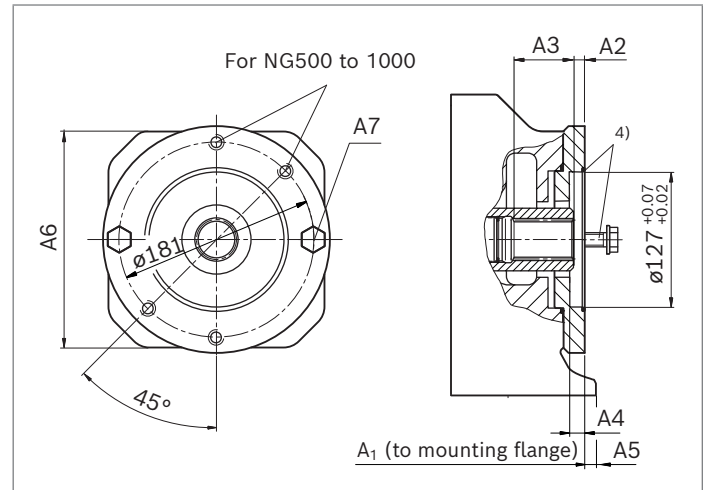

K24 (38-4 (C-C))							
NG	A1	A2	A3	A4	A5	A6	A7 <sup>3)5)</sup>
125	377	10.4	54	13	-	-	M16; 28 deep
180	401	10.4	54	13	-	-	M16; 28 deep
250	451	10.4	57.6	13	-	-	M16; 20 deep
355	480	10.4	57.6	13	-	-	M16; 20 deep
500	505	10.3	56.7	13	-	-	M16; 24 deep
750	555	10.3	56.7	13	23	250	M16; 24 deep
1000	628	10.4	56.6	13	25	280	M16; 32 deep

1) In accordance with ANSI B92.1a, 30° pressure angle, flat root, side fit, tolerance class 5

2) Mounting holes pattern viewed on through drive with control at top

3) Thread according to DIN 13; observe the maximum tightening torques in the instruction manual.

4) O-ring and mounting bolts included in delivery.

5) Design recommended according to VDI 2230, bolt grade 8.8 according to ISO 898-1

### Dimensions for through drives

Flange ISO 3019-1 (SAE J744)		Hub for splined shaft <sup>1)</sup>		Availability across sizes								Code	
Diameter	Mounting <sup>2)</sup>	Diameter		40	71	125	180	250	355	500	750	1000	
152-4 (B)		1 3/4in 13T 8/16DP		-	-	•	•	•	•	•	•	○	K17

• = Available    ○ = On request    - = Not available

▼ **152-4**

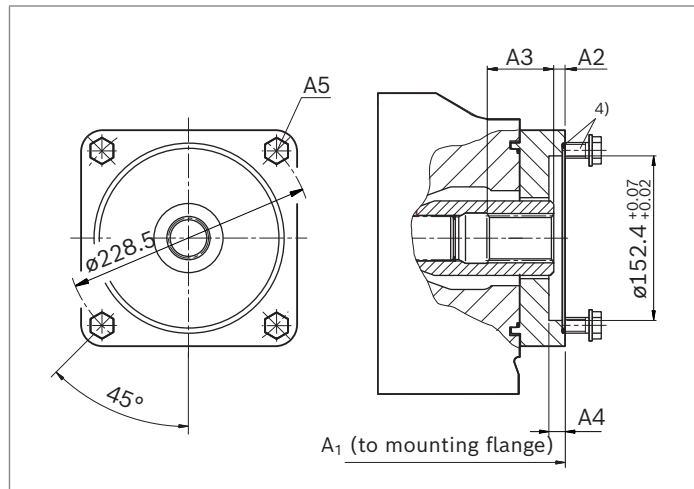

K17 (44-4 (D))					
NG	A1	A2	A3	A4	A5 <sup>3)5)</sup>
125	382	10.4	62	13	M16; 30 deep
180	406	10.4	62	13	M16; 30 deep
250	469	10.4	62	13	M16; 32 deep
355	498	10.4	62	13	M16; 32 deep
500	530	10.4	63.6	13	M16; 25 deep
750	580	10.4	63.6	13	M16; 25 deep

1) In accordance with ANSI B92.1a, 30° pressure angle, flat root, side fit, tolerance class 5  
 2) Mounting holes pattern viewed on through drive with control at top  
 3) Thread according to DIN 13; observe the maximum tightening torques in the instruction manual.

4) O-ring and mounting bolts included in delivery.  
 5) Design recommended according to VDI 2230, bolt grade 8.8 according to ISO 898-1

## Overview of mounting options

Through drive <sup>1)</sup>			Mounting options – 2nd pump				
Flange ISO 3019-2 (metric)	Hub for splined shaft	Code	A4VSO A4VSG NG (shaft)	A4CSG NG (shaft)	A10V(S)O/3x NG (shaft)	A10V(S)O/5x NG (shaft)	External gear pump
80-2	3/4in	KB2	–	–	18 (S, R)/31	10 (S)	–
100-2	7/8in	KB3	–	–	28 (S, R)/31	–	–
	1in	KB4	–	–	45 (S, R)/31	–	–
125-2	1 1/4in	KB5	–	–	71, 88 (S, R)/31	–	–
	1 1/2in	KB6	–	–	100 (S)/31	–	–
125-4	W32x2x14x9g	K31	40 (Z)	–	–	–	–
140-4	W40x2x18x9g	K33	71 (Z)	–	–	–	–
160-4	W50x2x24x9g	K34	125 (Z) 180 (Z)	–	–	–	–
	1 1/4in	KB8	–	–	71, 88 (S, R)/32	–	–
180-4	1 3/4in	KB7	–	–	140, 180 (S)/32	–	–
	1 1/2in	KB9	–	–	100 (S)	–	–
224-4	W60x2x28x9g	K35	250 (Z)	250 (Z)	–	–	–
	W70x3x22x0g	K77	355 (Z)	355 (Z)	–	–	–
315-8	W80x3x25x9g	K43	500 (Z)	500 (Z)	–	–	–
400-8	W90x3x28x9g	K76	750 (Z)	750 (Z)	–	–	–
	W100x3x32x9g	K88	1000 (Z)	–	–	–	–
Flange ISO 3019-1 (SAE J744)	Hub for splined shaft	Code	A4VSO A4VSG NG (shaft)	A4CSG NG (shaft)	A10V(S)O/3x NG (shaft)	A10V(S)O/5x NG (shaft)	External gear pump
82-2 (A)	5/8in	K01	–	–	–	–	Series F <sup>2)</sup>
	3/4in	K52	–	–	18 (S, R)/31	10, 18 (U)	–
101-2 (B)	7/8in	K68	–	–	28 (S, R)/31	28 (S)	Series N <sup>2)</sup>
	1in	K04	–	–	45 (S)/31	45 (S)	PGH 4
127-2 (C)	1 1/4in	K07	–	–	71, 88 (S)/31	–	–
	1 1/2in	K24	–	–	100 (S)/31	85 (S)	PGH 5
152-4 (D)	1 3/4in	K17	–	–	140, 180 (S)/32	–	–

1) Additional through drives are available on request

2) Bosch Rexroth recommends special versions of the external gear pumps. Please contact us.

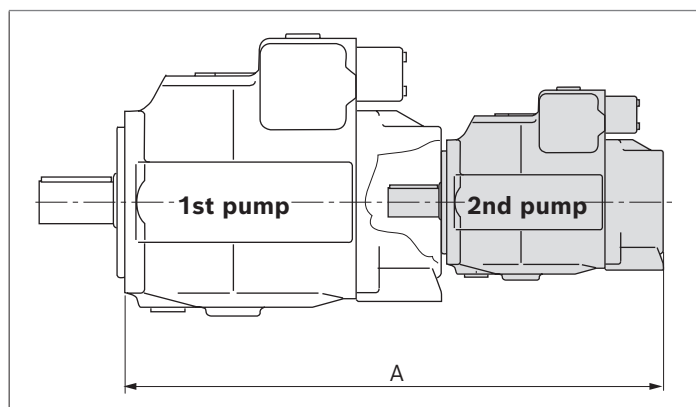
**Combination pumps A4VSG + A4VSG****Total length A**

A4VSG (1st pump)	A4VSG (2nd pump)								
	NG40	NG71	NG125	NG180	NG250	NG355	NG500	NG750	NG1000
NG40	570	–	–	–	–	–	–	–	–
NG71	598	622	–	–	–	–	–	–	–
NG125	655	679	743	–	–	–	–	–	–
NG180	679	703	766	778	–	–	–	–	–
NG250	713	737	832	844	912	–	–	–	–
NG355	Request	766	861	873	941	962	–	–	–
NG500	787	811	868	880	984	1005	1100	–	–
NG750	Request	Request	Request	Request	1034	Request	1150	1246	–
NG1000	Request	934	991	1003	1107	1128	1223	1319	1383

**Combination pumps A4VSG + A4VSO****Total length A**

A4VSG (1st pump)	A4VSO (2nd pump)								
	NG40	NG71	NG125	NG180	NG250	NG355	NG500	NG750	NG1000
NG40	554	–	–	–	–	–	–	–	–
NG71	582	611	–	–	–	–	–	–	–
NG125	639	668	735	–	–	–	–	–	–
NG180	663	692	758	778	–	–	–	–	–
NG250	697	726	824	844	904	–	–	–	–
NG355	Request	755	853	873	933	962	–	–	–
NG500	771	800	860	880	976	1005	1110	–	–
NG750	Request	Request	Request	Request	1026	Request	1160	1215	–
NG1000	Request	923	983	1003	1099	1128	1233	1288	1361

By using combination pumps, it is possible to have independent circuits without the need for splitter gearboxes.

When ordering combination pumps the type designations for the first and the second pump must be joined by a "+" and are combined into one part number. Each single pump should be ordered according to type code.

**Notice**

- ▶ The combination pump type code is shown in shortened form in the order confirmation.

**Example:**

**A4VSG 125 EO1/30R+A4VSG 71 HM1/10R**

- ▶ Each through drive is plugged with a **non-pressure-resistant** cover. This means the units must be sealed with a pressure-resistant cover before commissioning. Through drives can also be ordered with a pressure-resistant cover. Please specify in plain text.

**Order example:**

**A4VSG 125 EO1/30R-PPB10K339F**

**A4VSG 71 HM1/10R-PZB10N00N**

A tandem pump, with two pumps of equal size, is permissible without additional supports, assuming that the dynamic mass acceleration does not exceed maximum 10 g (= 98.1 m/s<sup>2</sup>).

For combination pumps consisting of more than two pumps, the mounting flange must be calculated for the permissible mass torque.

**Notice**

- ▶ Collisions with other attachment pumps may occur when controlling the combination pumps. Please check this using the appropriate data sheets for the individual pumps and controls, or contact us.

Details on the piping of the combination pumps can be found on page 49 to 50.

**Permissible moments of inertia**

Size			40	71	125	180	250	355	500	750	1000
Static	$T_m$	Nm	1800	2000	4200	4200	9300	9300	15600	19500	19500
Dynamic at 10 g (98.1 m/s <sup>2</sup> )	$T_m$	Nm	180	200	420	420	930	930	1560	1950	1950
Weight	$m$	kg	47	60	100	114	214	237	350	500	630
Distance from center of gravity	$l_1$	mm	120	140	170	180	210	220	230	260	290

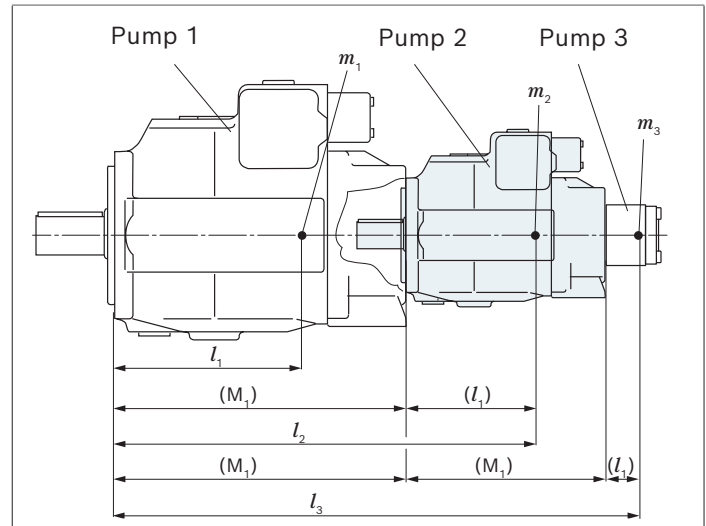

$m_1, m_2, m_3$  Weight of pump [kg]

$l_1, l_2, l_3$  Distance from center of gravity [mm]

$$T_m = (m_1 \cdot l_1 + m_2 \cdot l_2 + m_3 \cdot l_3) \cdot \frac{1}{102} \text{ [Nm]}$$

**Calculation for multiple pumps**

$l_1$  = Front pump distance from center of gravity (values from "Permissible moments of inertia" table)

$l_2$  = Dimension "M1" from through drive drawings (page 34 to 46) +  $l_1$  of the 2nd pump

$l_3$  = Dimension "M1" from through drive drawings (page 34 to 46) of pump 1 + "M1" of pump 2 +  $l_1$  of pump 3.

## Attachment of boost and control circuit pumps

Order code: H02, H04 and H06

As standard, we offer the following external gear pumps as boost and control circuit pumps for attachment:

Piped up attachment pump for		NG	40	71	125	180	250	355	500	750	1000	
<b>Code</b>	Through drive		K01		K68							K24
<b>H02</b>	The boost circuit											
	Design / type		F		N		-	-	-			PGH5
	Size		11	16	25	32	-	-			-	200
<b>H04</b>	Shared boost and control circuit (only EO1 and EO1K)											
	Design / type		F		N		-	-	-	-	-	-
	Size		-	16	25	-	-	-	-	-	-	-
<b>H06</b>	Shared boost and control circuit including pressure relief valve: DB 10 K2-4x/50YV to 50 bar (only HD1T and HD1U)											
	<b>Boost circuit</b>											
	Design / type		F		N		-	-	-	-	-	PGH5
	Size		11	16	25	32	-	-	-	-	-	200
	<b>Control circuit</b>											
	Design / type		F				-	-	-	-	-	PGF2
	Size		08				-	-	-	-	-	11

### Notice

- ▶ The shaft and flange of the external gear pumps AZP with the design F, N and G are adjusted for attachment on axial piston units and therefore special versions.  
More information on the dimensions and connection options as well as the operating conditions can be found in the data sheets:  
AZPF: 10089  
AZPN: 10091  
AZPG: 10093  
PGF2: 10213  
PGH4 and PGH5: 10223
- ▶ The leakage of the external gear pumps at different rotational speeds must be noted.

**H024 – A4VSG** with an attachment pump for the boost circuit, valve block with filter

- Circuit diagram H02
- For example: A4VSG...EPG with H024N
- NG 40 bis 180

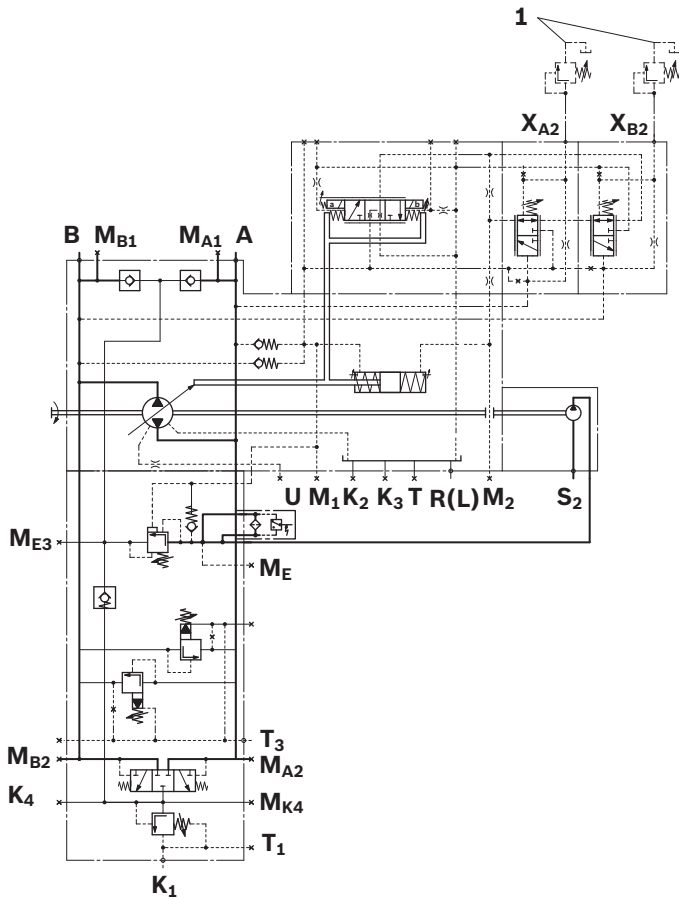

Ports for		State <sup>1)</sup>
<b>A, B</b>	Working line (pressure port)	O
<b>S</b>	Suction line - attachment pump	Piped up
<b>R(L)</b>	Fill and air bleeding (drain port)	O
<b>K<sub>1</sub></b>	Fill and air bleeding (drain port)	X
<b>K<sub>2</sub>, K<sub>3</sub></b>	Fill and air bleeding (drain port)	X
<b>K<sub>4</sub></b>	Accumulator port	X
<b>T</b>	Fluid drain	X
<b>T<sub>1</sub></b>	Pressure relief valve unloading port	X
<b>T<sub>3</sub></b>	Pressure relief valve unloading port	O
<b>E<sub>1</sub></b>	Filter, supply	X
<b>E<sub>2</sub></b>	Filter, return	X
<b>X<sub>A2</sub>, X<sub>B2</sub></b>	Pilot pressure port for pressure controller	O
<b>M<sub>E3</sub></b>	Measuring boost pressure	X
<b>M<sub>E</sub></b>	Measuring boost pressure supply	X
<b>M<sub>K4</sub></b>	Measuring boost pressure	X
<b>M<sub>A1</sub>, M<sub>B1</sub></b>	Measuring working pressure	X
<b>M<sub>A2</sub>, M<sub>B2</sub></b>	Measuring working pressure	X
<b>M<sub>1</sub>, M<sub>2</sub></b>	Measuring control pressure	X
<b>U</b>	Bearing flushing	X

1 Not included in scope of delivery

1) O = Must be connected (plugged on delivery)  
X = Plugged (in normal operation)



**For example: A4VSG 180....H024N**

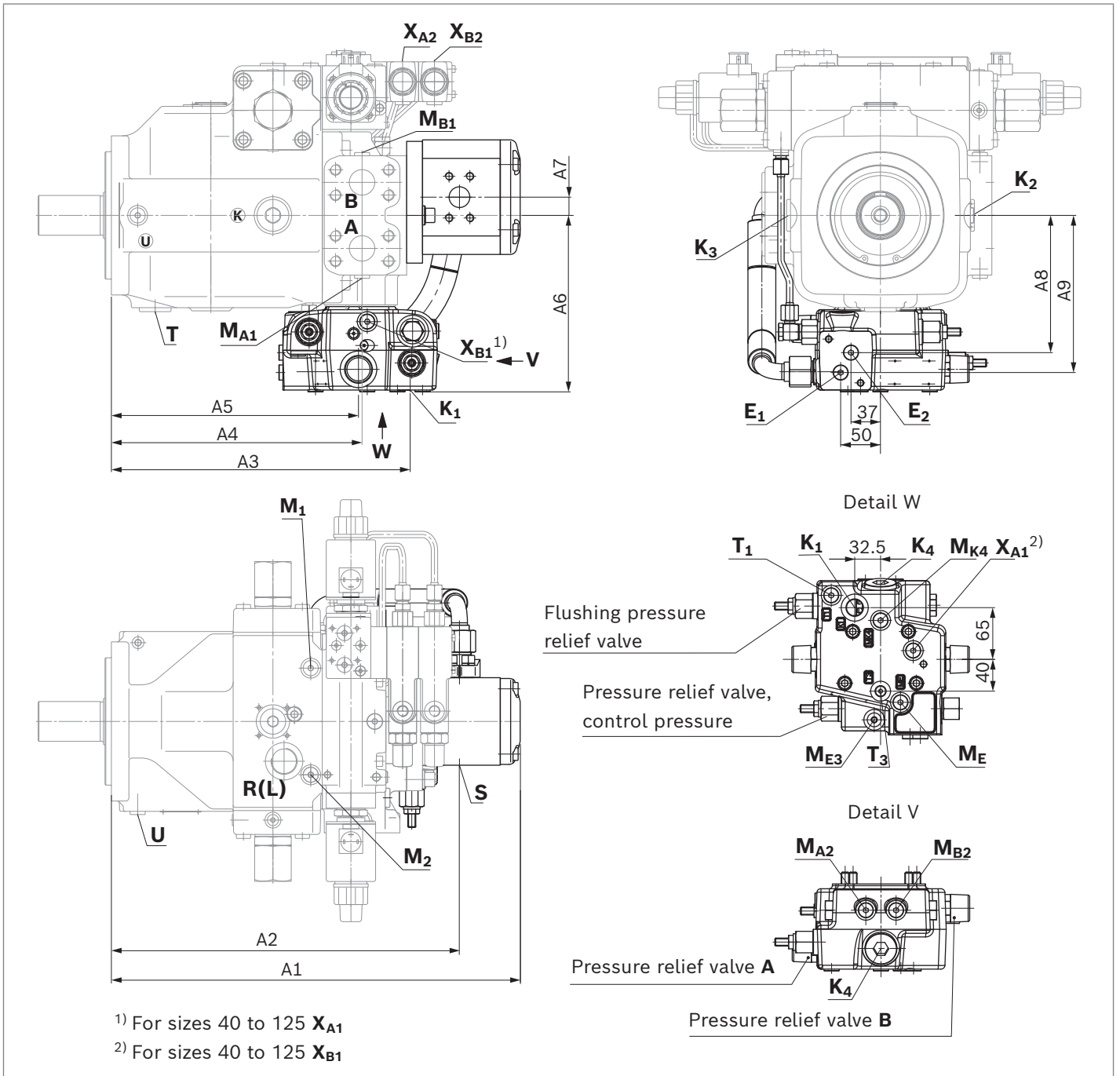

NG	A1	A2	A3	A4	A5	A6	A7	A8	A9
40	357	310	297	227	Request	194.3	18.8	150	175
71	395	338	322	258.5	257	196.8	18.7	Request	Request
125	463	402	376	315	311	217	22.9	172.5	197.5
180	495	430	375.5	315	310.5	221.8	22.9	172.5	197.5

**N009N – A4VSG** with valve block without filter

► Circuit diagram A4VSG...HDU with N009N, NG1000

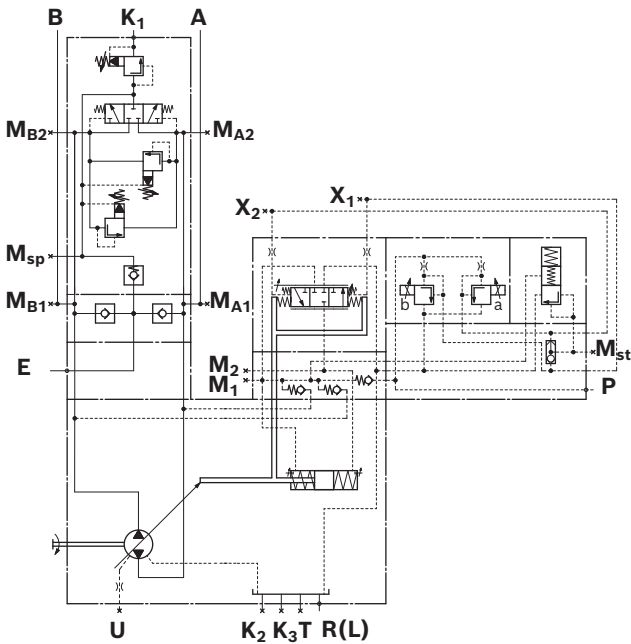

Ports for		State <sup>1)</sup>
<b>A, B</b>	Working line (pressure port)	O
<b>R(L)</b>	Fill and air bleeding (drain port)	O
<b>K<sub>1</sub></b>	Fill and air bleeding (drain port)	O
<b>K<sub>2</sub>, K<sub>3</sub></b>	Fill and air bleeding (drain port)	X
<b>T</b>	Fluid drain	X
<b>P</b>	Control pressure	O
<b>E</b>	Boost pressure supply	O
<b>M<sub>A1</sub>, M<sub>B1</sub></b>	Measuring working pressure	X
<b>M<sub>A2</sub>, M<sub>B2</sub></b>	Measuring working pressure	X
<b>M<sub>SP</sub></b>	Measuring flushing pressure	X
<b>M<sub>1</sub>, M<sub>2</sub></b>	Measurement of stroking chamber pressure	X
<b>X<sub>1</sub>, X<sub>2</sub></b>	Pilot pressure measuring	X
<b>M<sub>st</sub></b>	Pilot pressure measuring	X
<b>U</b>	Bearing flushing	X

**A4VSG 1000...N009N**

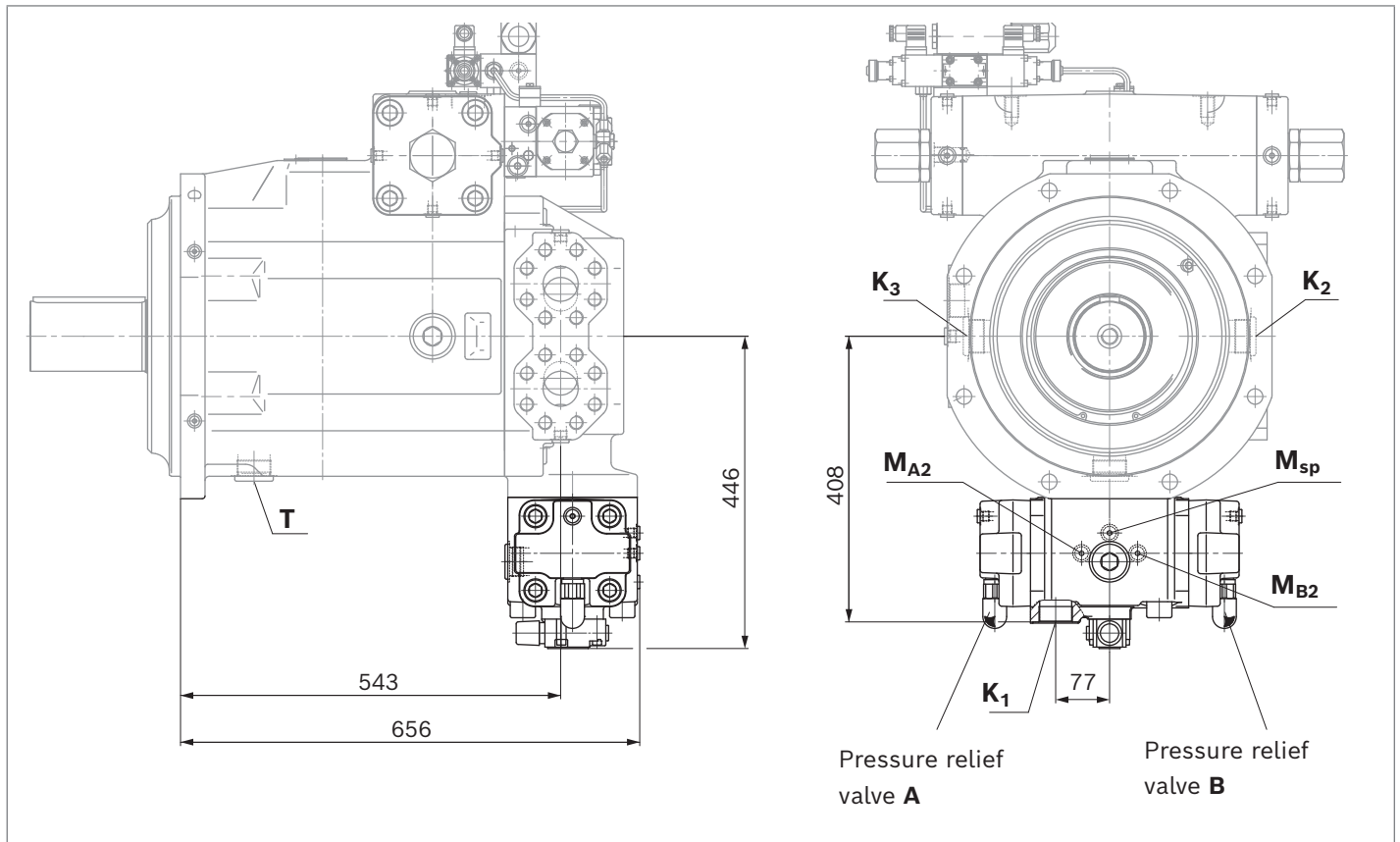

## Installation instructions

### General

The axial piston unit must be filled with hydraulic fluid and air bled during commissioning and operation. This must also be observed following a longer standstill as the axial piston unit may empty via the hydraulic lines. Particularly in the installation position "drive shaft upwards," filling and air bleeding must be carried out completely as there is, for example, a danger of dry running. The leakage in the housing area should be directed to the reservoir via the highest drain port (**T**, **R(L)**, **K<sub>2</sub>**, **K<sub>3</sub>**). For combination pumps, the leakage must be drained off at each single pump. If a shared drain line is used for several units, make sure that the respective case pressure in each unit is not exceeded. The shared drain line must be dimensioned to ensure that the maximum permissible case pressure of all connected units is not exceeded in any operating condition, particularly at cold start. If this is not possible, separate drain line must be laid. To prevent the transmission of structure-borne noise, use elastic elements to decouple all connecting lines from all vibration-capable components (e.g. reservoir, frame parts). Under all operating conditions, the suction lines and the drain lines must flow into the reservoir below the minimum fluid level.

### Notice

In certain installation positions, an influence on the adjustment or control can be expected. Gravity, dead weight and case pressure can cause minor characteristic shifts and changes in actuating time.

### Installation position

See the following examples **1** to **12** on the following pages. Further installation positions are available upon request. Recommended installation positions: **1** and **2**

Key	
<b>R(L)</b>	Filling / Air bleeding
<b>S</b>	Suction port attachment pump <sup>1)</sup>
<b>T, K<sub>2</sub>, K<sub>3</sub></b>	Drain port
<b>F</b>	Filling / Air bleeding
SB	Baffle (baffle plate)
$h_{t \min}$	Minimum required immersion depth (200 mm)
$h_{\min}$	Minimum required distance to reservoir bottom (100 mm)
$h_{ES \min}$	Minimum height required to prevent axial piston unit from draining (25 mm)
$h_{S \max}$	Maximum permissible suction height (800 mm)

### Notice

Port **F** is part of the external piping and must be provided on the customer side to make filling and air bleeding easier.

<sup>1)</sup> Information on the attachment pump can be found in the respective data sheets (see page 47)

**Below-reservoir installation (standard)**

Below-reservoir installation means that the axial piston unit is installed outside of the reservoir below the minimum fluid level.

▼ **Installation position 1**

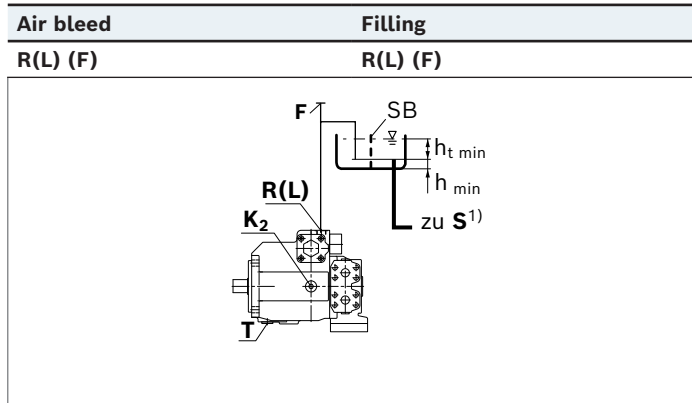

▼ **Installation position 2**

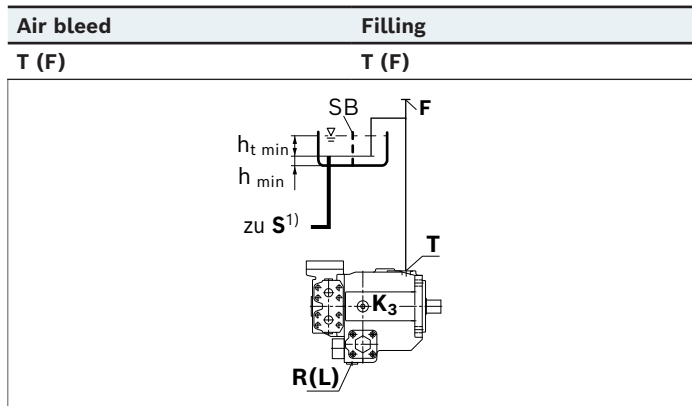

▼ **Installation position 3**

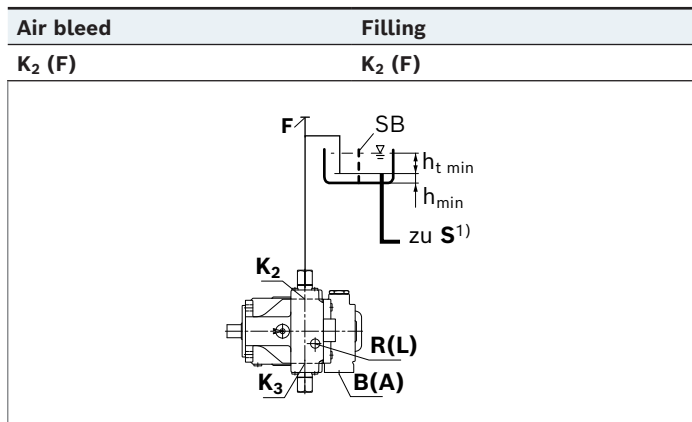

▼ **Installation position 4**

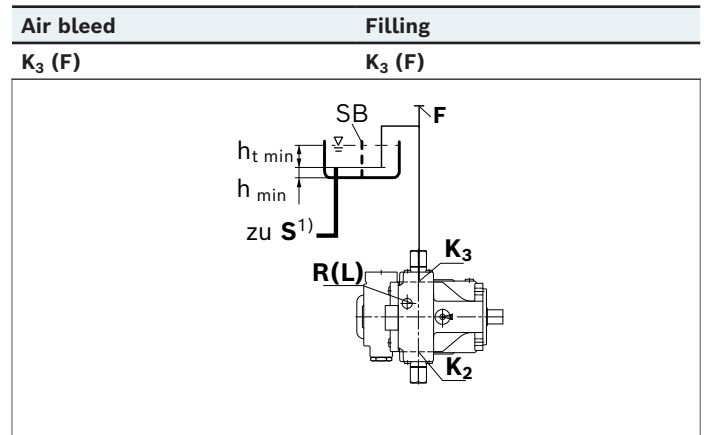

▼ **Installation position 5**

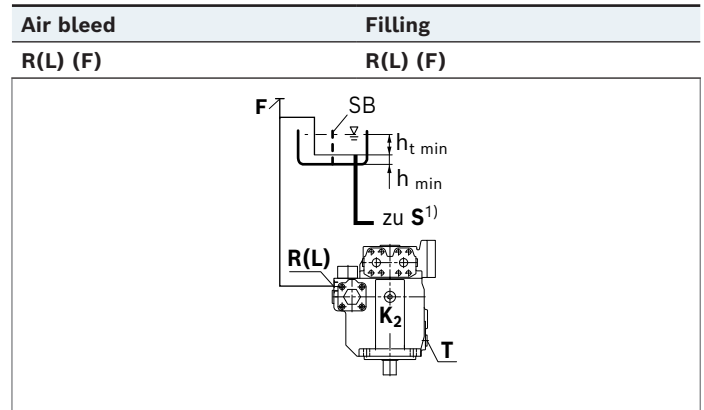

▼ **Installation position 6**

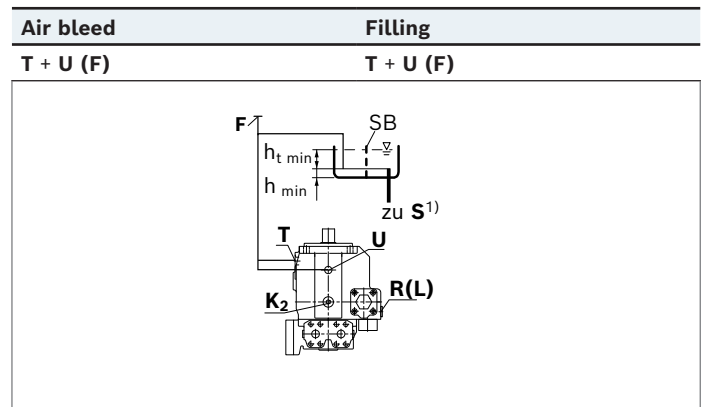

**Notice**

Bearing flushing at port **U** required.  
For information, see page 6

For key, see page 51

1) Information on the attachment pump can be found in the respective data sheets (see page 47)

**Above-reservoir installation**

Above-reservoir installation means that the axial piston unit is installed above the minimum fluid level of the reservoir. To prevent the axial piston unit from draining, a height difference  $h_{ES\ min}$  of minimum 25 mm at port **R(L)**, **T** is required in Position 12. Observe the maximum permissible suction height  $h_{S\ max} = 800\ mm$ .

▼ **Installation position 7**

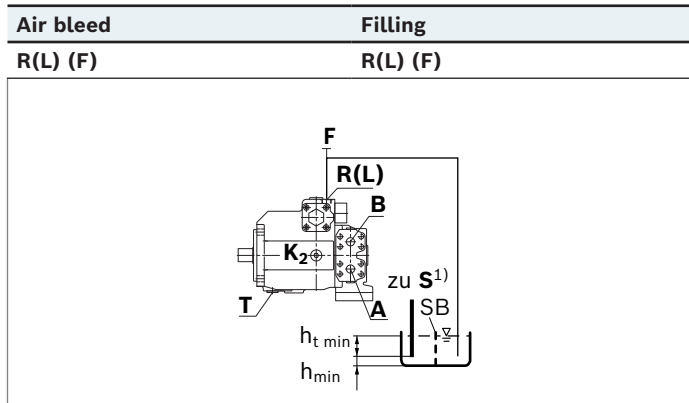

▼ **Installation position 8**

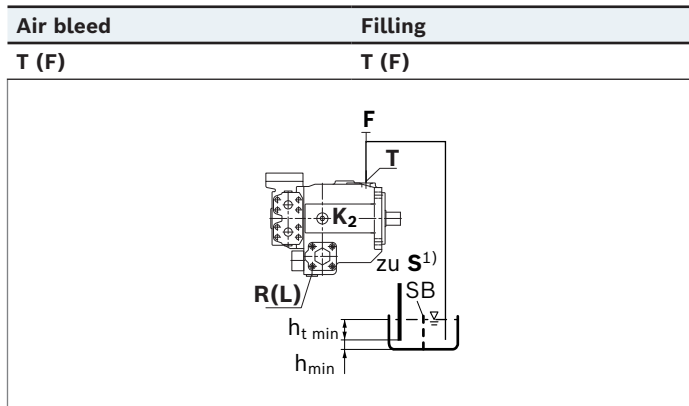

▼ **Installation position 9**

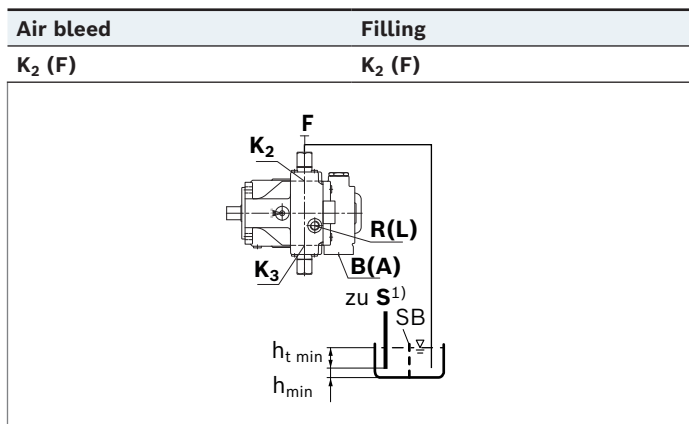

▼ **Installation position 10**

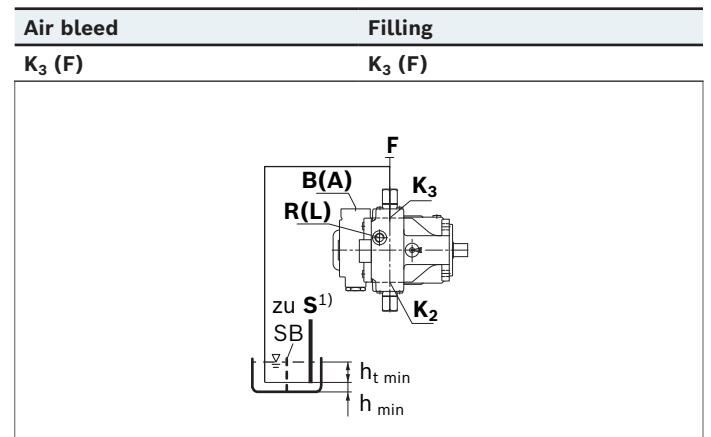

▼ **Installation position 11**

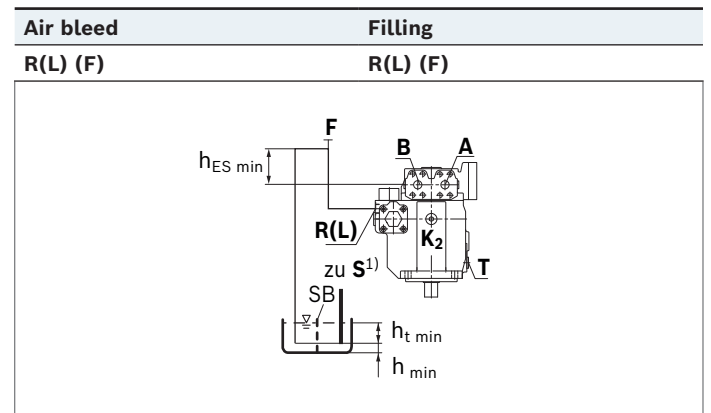

▼ **Installation position 12**

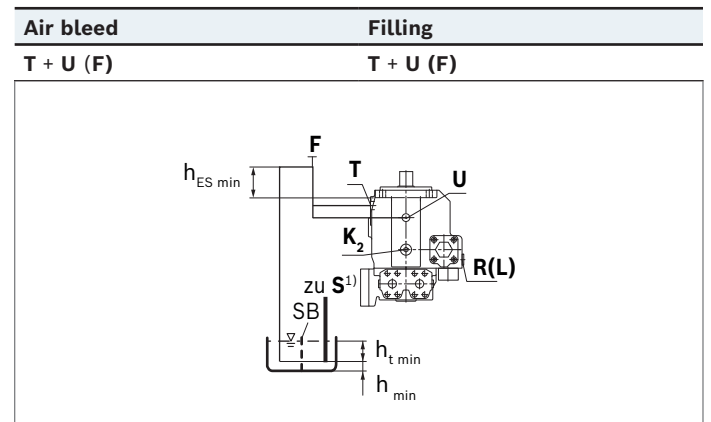

**Notice**

Bearing flushing at port **U** required.  
For information, see page 6

For key, see page 51

1) Information on the attachment pump can be found in the respective data sheets (see page 47)

## Project planning notes

- ▶ The axial piston variable pump A4VSG is intended for use in a closed circuit.
- ▶ The project planning, installation and commissioning of the axial piston unit requires the involvement of skilled personnel.
- ▶ Before using the axial piston unit, please read the corresponding instruction manual completely and thoroughly. If necessary, this can be requested from Bosch Rexroth.
- ▶ Before finalizing your design, please request a binding installation drawing.
- ▶ The specified data and notes contained herein must be observed.
- ▶ Depending on the operating conditions of the axial piston unit (working pressure, fluid temperature), the characteristic curve may shift.
- ▶ The characteristic curve may also shift due to the dither frequency or control electronics.
- ▶ Preservation: Our axial piston units are supplied as standard with preservation protection for a maximum of 12 months. If longer preservation protection is required (maximum 24 months), please specify this in plain text when placing your order. The preservation periods apply under optimal storage conditions, details of which can be found in the data sheet 90312 or the instruction manual.
- ▶ Not all versions of the product are approved for use in a safety function according to ISO 13849. Please consult the proper contact at Bosch Rexroth if you require reliability parameters (e.g.,  $MTTF_d$ ) for functional safety.
- ▶ Depending on the type of control used, electromagnetic effects can be produced when using solenoids. Applying a direct voltage signal (DC) to solenoids does not create electromagnetic interference (EMI) nor is the solenoid affected by EMI. Electromagnetic interference (EMI) potential exists when operating and controlling a solenoid with a modulated direct voltage signal (e.g. PWM signal) Appropriate testing and measures should be taken by the machine manufacturer to ensure other components or operators (e.g. with pacemaker) are not affected by this potential.
- ▶ Pressure cut-off (hydraulic or electronic) is not a sufficient safeguard against pressure overload. Therefore, a pressure relief valve must be added to the hydraulic system (integrated in the pump or external in the system). Observe the technical limits of the pressure relief valves here.
- ▶ For controllers requiring external pilot pressure, sufficient control fluid must be provided to the associated ports to ensure the required pilot pressures for the respective controller function. These controllers are subject to leakage due to their design. An increase in control fluid demand has to be anticipated over the total operating time. The design of the control fluid supply must thus be sufficiently large. If the control fluid is too low, the respective controller function may be impaired and undesired system behavior may result.
- ▶ For drives that are operated for a long period of time with constant rotational speed, the natural frequency of the hydraulic system can be stimulated by the excitation frequency of the pump (rotational speed frequency x 9). This can be prevented with suitably designed hydraulic lines.
- ▶ Please note the details regarding the tightening torques of port threads and other threaded joints in the instruction manual.
- ▶ The ports and fastening threads are designed for the  $p_{max}$  permissible pressures of the respective ports, see the connection tables. The machine or system manufacturer must ensure that the connecting elements and lines correspond to the specified application conditions (pressure, flow, hydraulic fluid, temperature) with the necessary safety factors.
- ▶ The service ports and function ports are only intended to accommodate hydraulic lines.

## Safety instructions

- ▶ During and shortly after operation, there is a risk of getting burnt on the axial piston unit and especially on the solenoids. Take the appropriate safety measures (e.g. by wearing protective clothing).
- ▶ Moving parts in control equipment (e.g. valve spools) can, under certain circumstances, get stuck in position as a result of contamination (e.g. contaminated hydraulic fluid, abrasion, or residual dirt from components). As a result, the hydraulic fluid flow and the build-up of torque in the axial piston unit can no longer respond correctly to the operator's specifications. Even the use of various filter elements (external or internal flow filtration) will not rule out a fault but merely reduce the risk. The machine/system manufacturer must test whether remedial measures are needed on the machine for the application concerned in order to bring the driven consumer into a safe position (e.g. safe stop) and ensure any measures are properly implemented.
- ▶ In certain conditions, moving parts in high-pressure relief valves might get stuck in an undefined position due to contamination (e.g. contaminated hydraulic fluid). This can result in restriction or loss of load-holding functions in lifting winches. The machine/system manufacturer must check whether additional measures are required on the machine for the relevant application in order to keep the load in a safe position and ensure they are properly implemented.

## Related documentation

### Product-specific documentation

Document type	Title	Document number
Data sheet	Axial piston units with DS2 secondary control A4VSG series 10 and 30	92058
	Axial piston units with secondary control DS3 A4VSG series 10 and 30	92063
	Control devices MA and EMA... for axial piston variable pump A4VSO and A4VSG	92072
	Control devices HM, HS5 and EO series 1x and 30	92076
	Control devices HD	92080
	Control devices EP	92084
	Axial piston variable pump A4CSG	92105
	Flush and pressure relief valve block SDVB	95533
	Flush and pressure relief valve block SDVB 16	95534
	Storage and preservation of axial piston units	90312
Instruction manuals	Axial piston variable pump A4VSG Series 1, 2 and 3	92100-01-B

### Documentation for hydraulic fluids

Document type	Title	Document number
Data sheet	Hydraulic fluids based on mineral oils and related hydrocarbons	90220
	Environmentally acceptable hydraulic fluids	90221
	Fire-resistant, water-free hydraulic fluids (HFDR/HFDU)	90222
	Fire-resistant, water-containing hydraulic fluids (HFAX, HFB, HCF)	90223
	Rating of hydraulic fluids used in Rexroth hydraulic components (pumps and motors)	90235
	Bosch Rexroth Fluid Rating List for Rexroth hydraulic components (pumps and motors)	90245

#### Bosch Rexroth AG

An den Kelterwiesen 14  
 72160 Horb a.N.  
 Germany  
 Phone +49 7451 92-0  
[sales.industry.horb@boschrexroth.de](mailto:sales.industry.horb@boschrexroth.de)  
[sales.mobile.horb@boschrexroth.de](mailto:sales.mobile.horb@boschrexroth.de)  
[www.boschrexroth.com](http://www.boschrexroth.com)

© Bosch Rexroth AG 1985. All rights reserved, also regarding any disposal, exploitation, reproduction, editing, distribution, as well as in the event of applications for industrial property rights. The data specified within only serves to describe the product. As our products are constantly being further developed, no statements concerning a certain condition or suitability for a certain application can be derived from our information. The information given does not release the user from the obligation of own judgment and verification. It must be remembered that our products are subject to a natural process of wear and aging.