

# Axial piston variable pump A4VG series 35

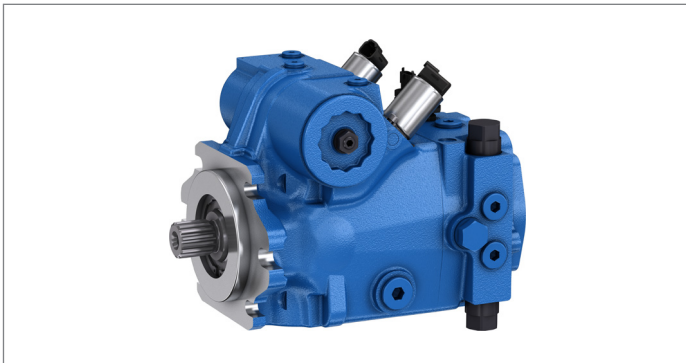

- ▶ High-pressure pump for applications in a closed circuit up to 530 bar
- ▶ Sizes 56 to 90
- ▶ Nominal pressure 400 bar
- ▶ Maximum pressure 530 bar

## Features

- ▶ High power density owing to a very high pressure level
- ▶ Integrated auxiliary pump for boost and pilot oil supply
- ▶ Flow direction changes when the swashplate is moved through the neutral position
- ▶ High-pressure relief valves with integrated boost function
- ▶ Boost-pressure relief valve
- ▶ Through drive for mounting additional pumps
- ▶ High total efficiency
- ▶ Swashplate design
- ▶ Compact design and high power density
- ▶ Especially suitable for use in electrified travel drives thanks to integrated sensors
- ▶ Supports the cross-linking of motor and machine control with the travel drive.

## Contents

Type code	2
Hydraulic fluid	4
Working pressure range	5
Technical data	7
ET – electronic control, direct-operated	10
Dimensions, size 56	13
Dimensions, size 71	16
Dimensions, size 90	19
Dimensions, through-drive	22
Overview of mounting options	26
Combination pumps A4VG + A4VG	27
High-pressure relief valves	28
Filtration in the boost pump suction line	30
Filtration in the boost pump pressure line	30
External boost pressure supply	31
Boost-pressure relief valve	31
Connector for the pressure reducing valve	32
Pressure sensor	32
Installation dimensions for coupling assembly	33
Installation instructions	34
Project planning notes	37
Safety instructions	38

## Type code

01	02	03	04	05	06	07	08	09	10	11	12	13	14	15	16	17	18	19	20	21	
<b>A4V</b>	<b>G</b>			<b>0</b>	<b>P</b>	<b>/</b>	<b>35</b>			<b>N</b>								<b>0</b>	<b>0</b>	<b>-</b>	

### Axial piston unit

01	Swashplate design, variable, nominal pressure 400 bar, maximum pressure 530 bar	<b>A4V</b>
----	---	------------

### Operating mode

02	Pump, closed circuit	<b>G</b>
----	----------------------	----------

### Size (NG)

03	Geometric displacement, see "Technical data" on page 7	<b>056</b>	<b>071</b>	<b>090</b>
		•	•	•

### Control device

		on-board voltage		<b>056</b>	<b>071</b>	<b>090</b>	
04	Electronic control	Direct-operated with two pressure reducing valves; prepared for BODAS Software	$U = 12\text{ V}$	•	•	•	<b>ETA</b>
			$U = 24\text{ V}$	•	•	•	<b>ETB</b>
	Direct-operated with two pressure reducing valves (DRE)	$U = 12\text{ V}$	•	•	•	<b>ET1</b>	
		$U = 24\text{ V}$	•	•	•	<b>ET2</b>	

### Additional function

05	Without additional function	<b>056</b>	<b>071</b>	<b>090</b>	<b>0</b>
		•	•	•	

### Connector for pressure reducing valve<sup>1)</sup>

06	DEUTSCH molded connector, 2-pin, DT04-2P – without suppressor diode	<b>056</b>	<b>071</b>	<b>090</b>	<b>P</b>
		•	•	•	

### Series

07	Series 3, index 5	<b>35</b>
----	-------------------	-----------

### Version of port and fastening threads

08	Metric ports according to ISO 6149 with O-ring seal, metric fastening thread according to DIN 13	<b>056</b>	<b>071</b>	<b>090</b>	<b>M</b>
	Ports according to ISO 11926 with O-ring seal (ANSI), metric fastening thread according to DIN 13 on the working port and on the through drive <sup>2)</sup>	•	•	•	<b>D</b>

### Direction of rotation

09	Viewed on drive shaft	Clockwise	<b>056</b>	<b>071</b>	<b>090</b>	<b>R</b>
		Counter-clockwise	•	•	•	<b>L</b>

### Sealing material

10	NBR (nitrile rubber), shaft seal in FKM (fluorocarbon rubber)	<b>056</b>	<b>071</b>	<b>090</b>	<b>N</b>
		•	•	•	

### Mounting flange

11	SAE J744	127-2	<b>056</b>	<b>071</b>	<b>090</b>	<b>C2</b>
		127-2/4	-	•	•	<b>C6</b>

### Drive shaft

12	Splined shaft ANSI B92.1a-1976	1 1/4 in 14T 12/24DP	<b>056</b>	<b>071</b>	<b>090</b>	<b>S7</b>
		1 3/8 in 21T 16/32DP	•	•	-	<b>V8</b>
		1 3/4 in 13T 8/16DP	-	-	•	<b>T1</b>
	Splined shaft DIN 5480	W35×2×16×9g	•	•	•	<b>Z8</b>

### Working port

13	Working port <b>A</b> and <b>B</b> , same side left	Suction port <b>S</b> bottom	<b>056</b>	<b>071</b>	<b>090</b>	<b>20</b>
	Working port <b>A</b> and <b>B</b> , same side right	Suction port <b>S</b> bottom	•	•	•	<b>21</b>

• = Available    ◦ = On request    - = Not available     = Preferred program

1) Connectors for other electric components may deviate.

2) Also applies to the version without through drive,

3) Observe the maximum permissible input torque

01	02	03	04	05	06	07	08	09	10	11	12	13	14	15	16	17	18	19	20	21	
<b>A4V</b>	<b>G</b>			<b>0</b>	<b>P</b>	<b>/</b>	<b>35</b>			<b>N</b>								<b>0</b>	<b>0</b>	<b>-</b>	

<b>Boost pump</b>																		<b>056</b>	<b>071</b>	<b>090</b>	
14	Without integrated boost pump																	•	•	•	<b>U</b>
	Integrated boost pump																	•	•	•	<b>G</b>

<b>Through-drive<sup>4)</sup></b>																		<b>056</b>	<b>071</b>	<b>090</b>	
15	Without through drive																	•	•	•	<b>0000</b>
	Flange SAE J744																				
	Diameter			Mounting <sup>5)</sup> Code			Hub for splined shaft <sup>6)</sup> Diameter			Code											
	82-2 (A)		⌀	A1		5/8 in 9T 16/32DP		S2		•	•	•	<b>A1S2</b>								
			∞	A2		5/8 in 9T 16/32DP		S2		•	•	•	<b>A2S2</b>								
	101-2 (B)		⌀	B1		7/8 in 13T 16/32DP		S4		•	•	•	<b>B1S4</b>								
			∞	B2		1 in 15T 16/32DP		S5		•	•	•	<b>B1S5</b>								
			∞			7/8 in 13T 16/32DP		S4		•	•	•	<b>B2S4</b>								
			∞			1 in 15T 16/32DP		S5		•	•	•	<b>B2S5</b>								
	127-2/4 (C)		⌀	C6		1 1/4 in 14T 12/24DP		S7		•	•	•	<b>C6S7</b>								
		⌀	C9		1 1/4 in 14T 12/24DP		S7		•	•	•	<b>C9S7</b>									

<b>High-pressure relief valve</b>																		<b>056</b>	<b>071</b>	<b>090</b>		
16	High-pressure relief valve, direct operated, fixed setting																					
																		Without bypass		•	•	•
																	With bypass		•	•	•	<b>C</b>

<b>Filtration boost circuit/external boost pressure supply</b>																		<b>056</b>	<b>071</b>	<b>090</b>	
17	Filtration in the boost pump suction line																	•	•	•	<b>S</b>
	Filtration in the boost pump pressure line, ports for external boost circuit filtration ( <b>F<sub>e</sub></b> and <b>F<sub>a</sub></b> )																	•	•	•	<b>D</b>
	External boost pressure supply (on version without integrated boost pump)																	•	•	•	<b>E</b>

<b>Pressure sensor</b>																		<b>056</b>	<b>071</b>	<b>090</b>	
18	Without pressure sensor																	•	•	•	<b>0</b>
	Pressure sensors at the measuring ports <b>M<sub>A</sub></b> and <b>M<sub>B</sub></b> (high pressure) <sup>7)</sup>																	•	•	•	<b>4</b>

<b>Other sensors 1</b>																		<b>056</b>	<b>071</b>	<b>090</b>	
19	Without sensor																	•	•	•	<b>0</b>

<b>Other sensors 2</b>																		<b>056</b>	<b>071</b>	<b>090</b>	
20	Without sensor																	•	•	•	<b>0</b>

<b>Standard/special version</b>																					
21	Standard version																	•	•	•	<b>0</b>
	Standard version with installation variants, e.g. <b>T</b> ports open or closed, contrary to standard																	•	•	•	<b>Y</b>
	Special version																	•	•	•	<b>S</b>

• = Available    ◦ = On request    - = Not available     = Preferred program

**Notice**

- ▶ Note the project planning notes on page 37!
- ▶ In addition to the type code, please specify the relevant technical data when placing your order.
- ▶ Please note that not all type code combinations are available although the individual functions are marked as being available.

4) Specifications for the version with integrated boost pump, please contact us for the version without boost pump  
5) Mounting hole pattern viewed on through drive, control at top  
6) Hub for splined shaft according to ANSI B92.1a-1976 (drive shaft allocation according to SAE J744)  
7) Specify type code of pressure sensor acc. to data sheet PR4 (95156) separately and observe the requirements for the electronics

## Hydraulic fluid

The axial piston unit is designed for operation with HLP mineral oil according to DIN 51524.

Application instructions and requirements for hydraulic fluid selection, behavior during operation as well as disposal and environmental protection should be taken from the following data sheets before the start of project planning:

- ▶ 90220: Hydraulic fluids based on mineral oils and related hydrocarbons
- ▶ 90221: Environmentally acceptable hydraulic fluids
- ▶ 90222: Fire-resistant, water-free hydraulic fluids (HFDR/HFDU)
- ▶ 90225: Limited technical data for operation with water-free and water-containing fire-resistant hydraulic fluids (HFDR, HFDU, HFAE, HFAS, HFB, HFC)

### Selection of hydraulic fluid

Bosch Rexroth evaluates hydraulic fluids on the basis of the Fluid Rating according to the technical data sheet 90235.

Hydraulic fluids with positive evaluation in the Fluid Rating are provided in the following technical data sheet:

- ▶ 90245: Bosch Rexroth Fluid Rating List for Rexroth hydraulic components (pumps and motors)

Selection of hydraulic fluid shall make sure that the operating viscosity in the operating temperature range is within the optimum range ( $v_{opt}$ ; see selection diagram).

### Viscosity and temperature of hydraulic fluids

	Viscosity	Shaft seal	Temperature <sup>3)</sup>	Comment
Cold start	$v_{max} \leq 1600 \text{ mm}^2/\text{s}$	NBR <sup>2)</sup>	$\vartheta_{St} \geq -40 \text{ }^\circ\text{C}$	$t \leq 3 \text{ min}$ , without load ( $p \leq 50 \text{ bar}$ ), $n \leq 1000 \text{ rpm}$ Permissible temperature difference between axial piston unit and hydraulic fluid in the system maximum 25 K
		FKM	$\vartheta_{St} \geq -25 \text{ }^\circ\text{C}$	
Warm-up phase	$v = 1600 \dots 400 \text{ mm}^2/\text{s}$			$t \leq 15 \text{ min}$ , $p \leq 0.7 \times p_{nom}$ and $n \leq 0.5 \times n_{nom}$
Continuous operation	$v = 400 \dots 10 \text{ mm}^2/\text{s}^{1)}$	NBR <sup>2)</sup>	$\vartheta \leq +85 \text{ }^\circ\text{C}$	Measured at port <b>T</b>
		FKM	$\vartheta \leq +110 \text{ }^\circ\text{C}$	
	$v_{opt} = 36 \dots 16 \text{ mm}^2/\text{s}$			Optimal operating viscosity and efficiency range
Short-term operation	$v_{min} = 10 \dots 7 \text{ mm}^2/\text{s}$	NBR <sup>2)</sup>	$\vartheta \leq +85 \text{ }^\circ\text{C}$	$t \leq 3 \text{ min}$ , $p \leq 0.3 \times p_{nom}$ , measured at port <b>T</b>
		FKM	$\vartheta \leq +110 \text{ }^\circ\text{C}$	

**Notice:** The maximum circuit temperature of +115 °C must not be exceeded at the working ports **A** and **B** complying with the permissible viscosity.

### ▼ Selection diagram

Maximum permissible viscosity on cold start

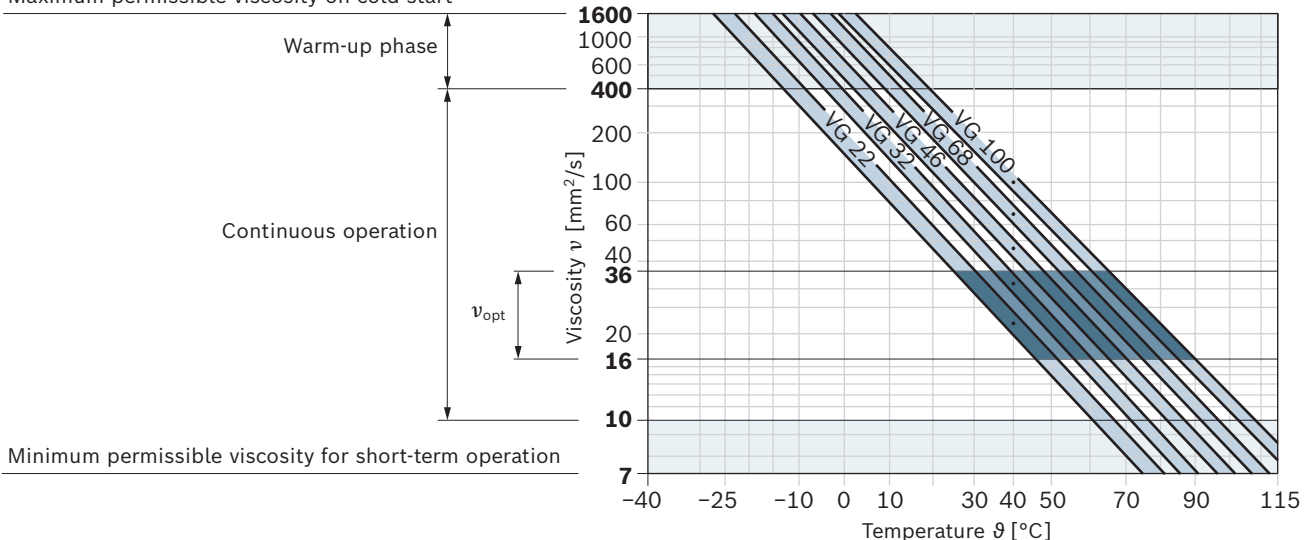

1) This corresponds, for example on the VG 46, to a temperature range of +4 °C to +85 °C (see selection diagram)

2) Special version, please contact us

3) If the temperature at extreme operating parameters cannot be adhered to, please contact us.

### Filtration of the hydraulic fluid

Finer filtration improves the cleanliness level of the hydraulic fluid, which increases the service life of the axial piston unit.

A cleanliness level of at least 20/18/15 is to be maintained according to ISO 4406.

At a hydraulic fluid viscosity of less than 10 mm<sup>2</sup>/s (e.g. due to high temperatures during short-term operation), a cleanliness level of at least 19/17/14 according to ISO 4406 is required.

Examples of temperatures of hydraulic fluids at a viscosity of 10 mm<sup>2</sup>/s:

- ▶ 73 °C at HLP 32
- ▶ 85 °C at HLP 46

### Working pressure range

Pressure at working port A or B		Definition
Nominal pressure $p_{nom}$	400 bar	The nominal pressure corresponds to the maximum design pressure.
Maximum pressure $p_{max}$	450 bar	The maximum pressure corresponds to the maximum working pressure within a single operating period. The sum of single operating periods must not exceed the total operating period. Within the total operating period of 300 h, a maximum pressure of 450 bar to 530 bar is permissible for a limited period of 50 h. With 530 bar, the axial piston unit may thereby only be swiveled out by a maximum of 75%, see characteristic curve "maximum pressure $p_{max}$ up to 530 and total operating period" on page 6.
Maximum single operating period	10 s	
Total operating period	300 h	
Swivel angle	100%	
Maximum pressure $p_{max}$	530 bar	Observe the information regarding "Project planning with a maximum pressure from 450 bar to 530 bar" on page 6.
Maximum single operating period	10 s	
Total operating period	50 h	
Swivel angle	maximum 75%	
Minimum pressure (low-pressure side)	10 bar above case pressure	Minimum pressure on the low-pressure side ( <b>A</b> or <b>B</b> ) required to prevent damage to the axial piston unit.
Rate of pressure change $R_{A_{max}}$	9000 bar/s	Maximum permissible speed of pressure build-up and reduction during a pressure change across the entire pressure range.
<b>Boost pump</b>		
Nominal pressure $p_{Sp_{nom}}$	25 bar	
Maximum pressure $p_{Sp_{max}}$	30 bar	
Pressure at suction port <b>S</b> (inlet)		
Continuous $p_{S_{min}}$	≥0.8 bar absolute	$v \leq 30 \text{ mm}^2/\text{s}$
Short-term, at a cold start	≥0.5 bar absolute	$t < 3 \text{ min}$
Maximum pressure $p_{S_{max}}$	≤5 bar absolute	
<b>Control pressure</b>		
Required control pressure $p_{St}$ at $n = 2000 \text{ rpm}$	25 bar above case pressure	Required control pressure $p_{St}$ , to ensure the function of the control. The required control pressure is dependent on the rotational speed and working pressure.
<b>Case pressure at port T</b>		
Continuous differential pressure $\Delta p_{T_{cont}}$	2 bar	Maximum, averaged differential pressure at the shaft seal (case pressure to ambient pressure)
Maximum differential pressure $\Delta p_{T_{max}}$	See the diagram	Permissible differential pressure at the shaft seal (case pressure to ambient pressure)
Pressure peaks $p_{T_{peak}}$	10 bar	$t < 0.1 \text{ s}$ , maximum 1000 pressure peaks permissible

▼ **Maximum pressure  $p_{max}$  up to 450 bar and total operating period**

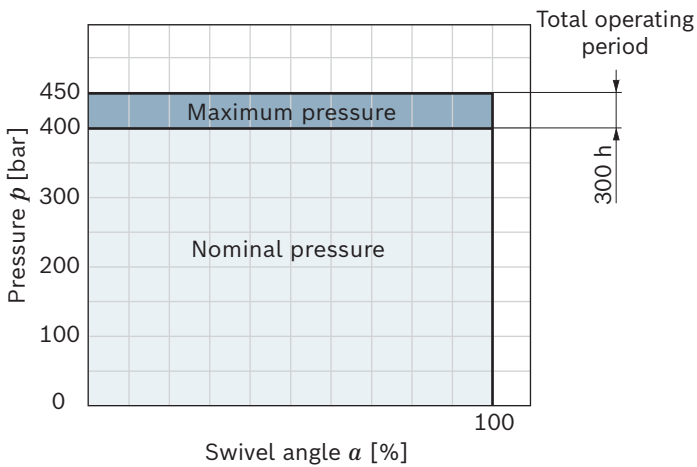

▼ **Maximum differential pressure at the shaft seal**

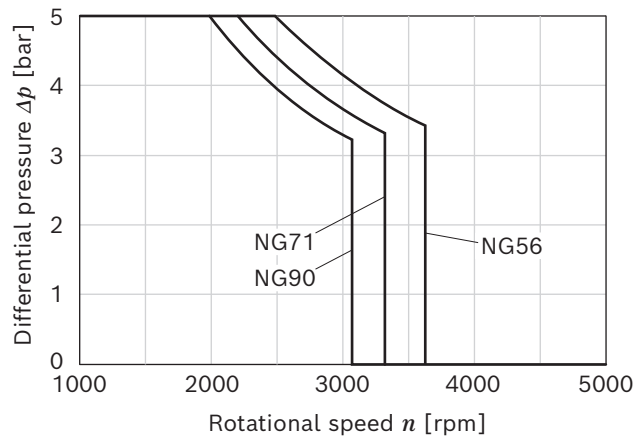

▼ **Maximum pressure  $p_{max}$  up to 530 bar and total operating period**

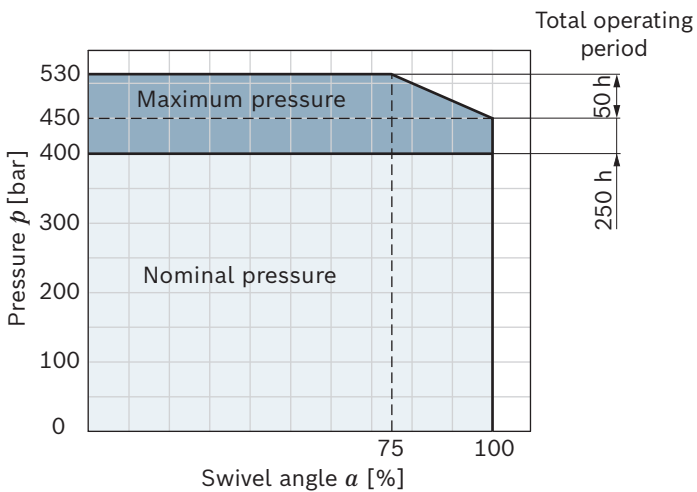

▼ **Pressure definition**

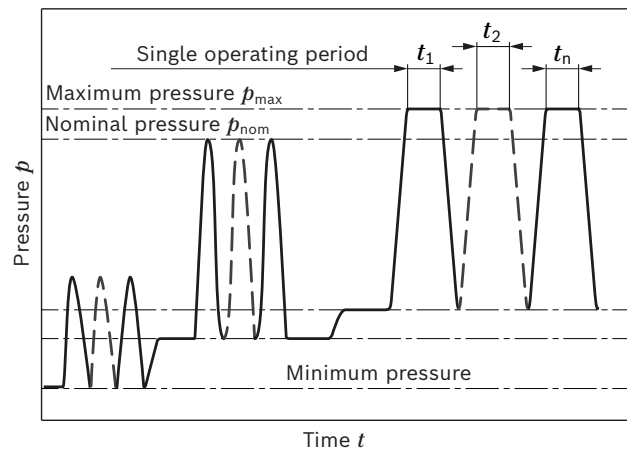

Total operating period =  $t_1 + t_2 + \dots + t_n$

▼ **Rate of pressure change  $R_{Amax}$**

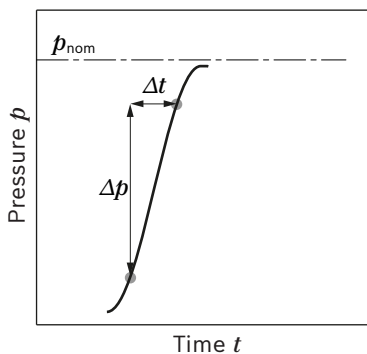

**Notice**

- ▶ Working pressure range applies when using hydraulic fluids based on mineral oils. Please contact us for values for other hydraulic fluids.
- ▶ In addition to the hydraulic fluid and the temperature, the service life of the shaft seal is influenced by the rotational speed of the axial piston unit and the case pressure.
- ▶ The service life of the shaft seal decreases with increasing frequency of pressure peaks and increasing mean differential pressure.
- ▶ The case pressure must be greater than the external pressure (ambient pressure) at the shaft seal.
- ▶ Project planning with a maximum pressure from 450 bar to 530 bar must be realized via your competent contact partner at Bosch Rexroth.

## Technical data

Size		NG		56	71	90	
Geometric displacement, per revolution	Variable pump	$V_{g \max}$	cm <sup>3</sup>	56	71	90	
	Boost pump (at $p = 20$ bar)	$V_{g Sp}$	cm <sup>3</sup>	13.8	18.9	18.9	
Rotational speed <sup>1)</sup>	maximum at $V_{g \max}$	$n_{nom S}$	rpm	3600	3300 <sup>2)</sup>	3050	
	at $\Delta p \geq 40$ bar ( $t < 15$ s)	$n_{max 40}$	rpm	4050	On request	3500	
	minimum	$n_{min}$	rpm	500	500	500	
Flow	at $n_{nom}$ and $V_{g \max}$	$q_v$	l/min	202	234	275	
Power <sup>3)</sup>	at $n_{nom}$ , $V_{g \max}$ and $\Delta p = 400$ bar	$P$	kW	134	156	183	
Torque <sup>3)</sup>	at $V_{g \max}$ and	$\Delta p = 400$ bar	$M$	Nm	357	452	573
		$\Delta p = 100$ bar	$M$	Nm	89	113	143
Rotary stiffness of drive shaft	S7	$c$	kNm/rad	80.8	98.8	107.6	
	V8	$c$	kNm/rad	95	120.9	–	
	T1	$c$	kNm/rad	–	–	158.1	
	Z8	$c$	kNm/rad	95.8	122.8	137	
Moment of inertia of the rotary group		$J_{TW}$	kgm <sup>2</sup>	0.0066	0.0097	0.0149	
Maximum angular acceleration <sup>4)</sup>		$\alpha$	rad/s <sup>2</sup>	24000	21000	18000	
Case volume		$V$	l	1.6	2.1	2.0	
Weight (without through drive) approx. <sup>5)</sup>		$m$	kg	37	48	49	

### Notice

- ▶ Theoretical values, without efficiency and tolerances; values rounded
- ▶ Operation above the maximum values or below the minimum values may result in a loss of function, a reduced service life or in the destruction of the axial piston unit. Bosch Rexroth recommends testing the loads by means of experiment or calculation / simulation and comparison with the permissible values.

### Determination of the characteristics

Flow	$q_v = \frac{V_g \times n \times \eta_v}{1000}$	[l/min]
Torque	$M = \frac{V_g \times \Delta p}{20 \times \pi \times \eta_{hm}}$	[Nm]
Power	$P = \frac{2 \pi \times M \times n}{60000} = \frac{q_v \times \Delta p}{600 \times \eta_t}$	[kW]

### Key

$V_g$	Displacement per revolution [cm <sup>3</sup> ]
$\Delta p$	Differential pressure [bar]
$n$	Rotational speed [rpm]
$\eta_v$	Volumetric efficiency
$\eta_{hm}$	Hydraulic-mechanical efficiency
$\eta_t$	Total efficiency ( $\eta_t = \eta_v \times \eta_{hm}$ )

- 1) The values are applicable:
  - for the optimum viscosity range from  $v_{opt} = 36$  to  $16$  mm<sup>2</sup>/s
  - for hydraulic fluid based on mineral oils (for HF hydraulic fluids, observe the technical data in 90225)
- 2) Valid for a suction pressure of 0.9 bar absolute. With a suction pressure of 0.8 bar absolute, the maximum permissible rotational speed is 3200 rpm, for the version without integrated boost pump, the speed limitation below 3300 rpm does not apply.
- 3) Without boost pump
- 4) The data are valid for values between the minimum required and maximum permissible rotational speed.
 

Valid for external excitation (e.g. diesel engine 2 to 8 times the rotary frequency; cardan shaft 2 times the rotary frequency).  
The limit value is only valid for a single pump.  
The load capacity of the connection parts must be considered.
- 5) Weight may vary by equipment.

**Permissible radial and axial loading of the drive shaft**

▼ **Splined shaft ANSI B92.1a**

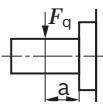
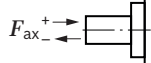
Size	NG		56	56	71	71	90	90	
Drive shaft		in	1 1/4	1 3/8	1 1/4	1 3/8	1 1/4	1 3/4	
Maximum radial force at distance a (from shaft collar)		$F_{q \max}$	N	4772	4338	6050	5500	7670	5478
		a	mm	24	24	24	24	24	33.5
Maximum axial force		$+ F_{ax \max}$	N	2910	2910	4242	4242	4330	4330
		$- F_{ax \max}$	N	1490	1490	2758	2758	2670	2670

▼ **Splined shaft DIN 5480**

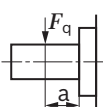
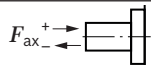
Size	NG		56	71	90	
Drive shaft			W35	W35	W35	
Maximum radial force at distance a (from shaft collar)		$F_{q \max}$	N	4329	5489	6957
		a	mm	20	20	20
Maximum axial force		$+ F_{ax \max}$	N	2910	4242	4330
		$- F_{ax \max}$	N	1490	2758	2670

**Notice**

- ▶ The axial and radial loading generally influence the bearing service life.
- ▶ Special requirements apply in the case of belt drive and cardan shaft. Please contact us.

**Permissible input and through-drive torques**

Size	NG		56	71	90
Torque at $V_{g \max}$ and $\Delta p = 400 \text{ bar}^{1)}$	$M$	Nm	357	452	573
Maximum input torque on drive shaft <sup>2)</sup>					
ANSI B92.1a-1976	<b>S7</b> 1 1/4 in	$M_{E \max}$	Nm	602	602 <sup>3)</sup>
	<b>V8</b> 1 3/8 in	$M_{E \max}$	Nm	970	-
	<b>T1</b> 1 3/4 in	$M_{E \max}$	Nm	-	1640
DIN 5480	<b>Z8</b> W35	$M_{E \max}$	Nm	912	912
Maximum through-drive torque	$M_{D \max}$	Nm	521	660	822

▼ **Distribution of torques**

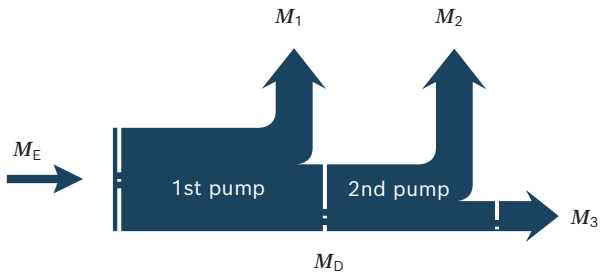

Torque at 1st pump	$M_1$
Torque at 2nd pump	$M_2$
Torque at 3rd Pump	$M_3$
Input torque	$M_E = M_1 + M_2 + M_3$
	$M_E < M_{E \max}$
Through-drive torque	$M_D = M_2 + M_3$
	$M_D < M_{D \max}$

1) Efficiency not considered  
 2) For drive shafts free of radial force  
 3) Observe the maximum permissible input torque

## ET – electronic control, direct-operated

### ETA/ETB – two pressure reducing valves; prepared for BODAS Application Software or software modules

The ETA/ETB control is optimized for electronic drives and is intended to be used together with the BODAS Application Software or software modules.

Here, all relevant configuration options have already been predefined and ensure an optimal interaction of pump and software thanks to the standardization. The pump function is largely determined by the software used.

The output flow of the pump is infinitely variable in the range between 0 and 100 %. Depending on the preselected current  $I$  at solenoids **a** and **b** of the pressure reducing valves, the stroking cylinder of the pump is proportionally supplied with control pressure. The two control pressures  $X_1$  and  $X_2$  can be controlled independently. The pump displacement that arises at a certain control current is dependent on the rotational speed and working pressure of the pump. A different flow direction is associated with each pressure reducing valve.

Maximum permissible control pressure: 30 bar.

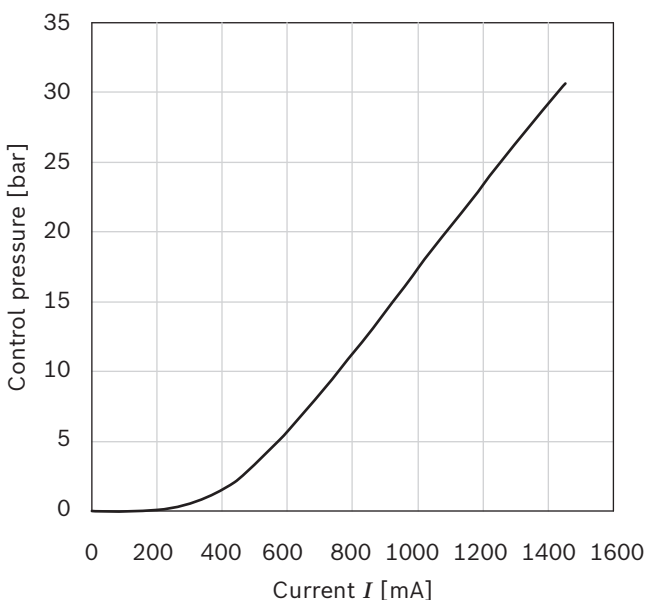

1) For further information on the pressure reducing valve, see data sheet 64659.

**Notice:** The leakage flow and the control flow differ from the parameter in data sheet 64659.

Technical data, pressure reducing valve <sup>1)</sup>	ETA	ETB
On-board voltage in the vehicle	12 V	24 V
Permissible voltage $U$	9.6 ... 28.8 V	
Current limit	1.45 A	
Nominal resistance (at 20 °C)	4.05 $\Omega$	
Dither		
Frequency	100 Hz	
Minimum oscillation range <sup>2)</sup>	250 mA	
Duty cycle	100%	
Type of protection: see connector version page 32		

### Notice

All control-relevant data are already stored in the software.

### ▼ Circuit diagram

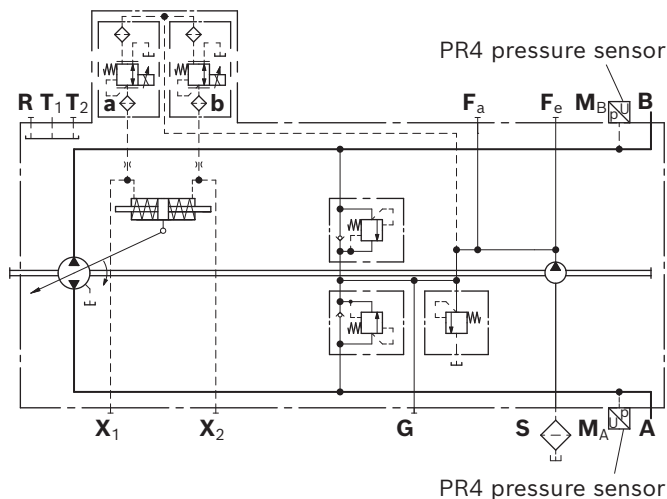

2) Minimum required oscillation range of the control current  $\Delta I_{p-p}$  (peak to peak) within the respective control range (start of control to end of control)

Correlation of direction of rotation, control and flow direction				
Direction of rotation	Clockwise		Counter-clockwise	
Actuation of pressure reducing valve	<b>a</b>	<b>b</b>	<b>a</b>	<b>b</b>
Control pressure	<b>X<sub>1</sub></b>	<b>X<sub>2</sub></b>	<b>X<sub>1</sub></b>	<b>X<sub>2</sub></b>
Flow direction	<b>A to B</b>	<b>B to A</b>	<b>B to A</b>	<b>A to B</b>
Working pressure	<b>M<sub>B</sub></b>	<b>M<sub>A</sub></b>	<b>M<sub>A</sub></b>	<b>M<sub>B</sub></b>

▼ **Position of ports (example)**

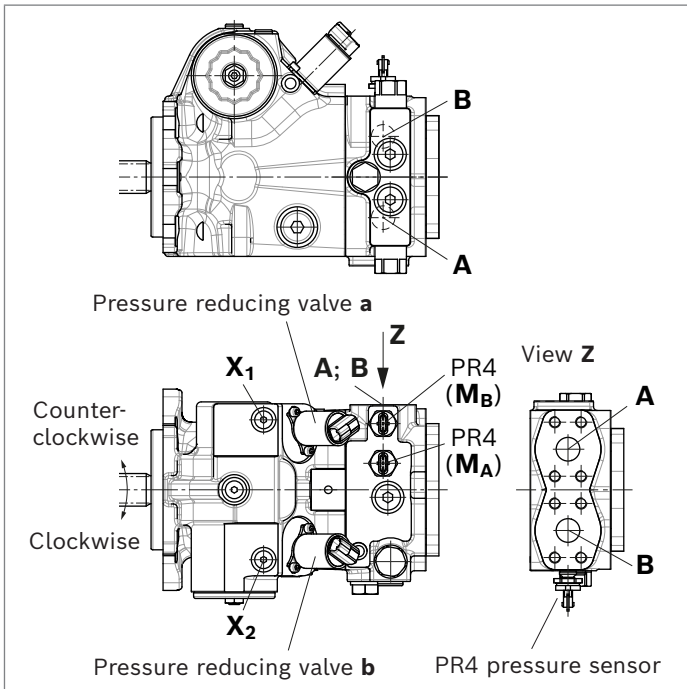

**ET1/ET2 – two pressure reducing valves**

The output flow of the pump is infinitely variable in the range between 0 and 100 %. Depending on the pre-selected current  $I$  at solenoids **a** and **b** of the pressure reducing valves, the stroking cylinder of the pump is proportionally supplied with control pressure. The two control pressures  $X_1$  and  $X_2$  can be controlled independently. The pump displacement that arises at a certain control current is dependent on the rotational speed and working pressure of the pump. A different flow direction is associated with each pressure reducing valve.

Maximum permissible control pressure: 30 bar.

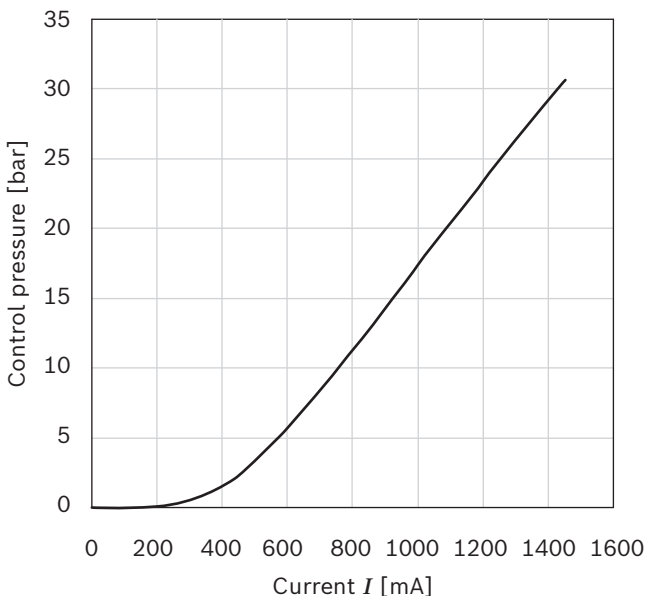

Technical data, pressure reducing valve <sup>1)</sup>	ET1	ET2
On-board voltage in the vehicle	12 V	24 V
Permissible voltage $U$	9.6 to 28.8 V	
Current limit	1.45 A	
Nominal resistance (at 20 °C)	4.05 $\Omega$	
Dither		
Frequency	100 Hz	
Minimum oscillation range <sup>2)</sup>	250 mA	
Duty cycle	100%	
Type of protection: see connector version page 32		

1) For further information on the pressure reducing valve, see data sheet 64659.

**Notice:** The leakage flow and the control flow differ from the parameter in data sheet 64659.

**▼ Circuit diagram**

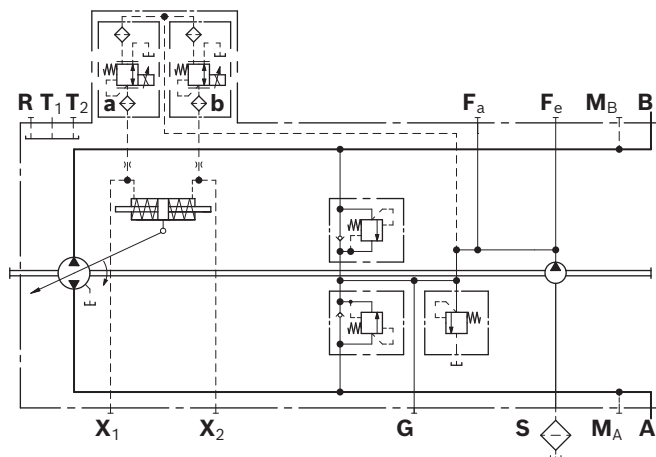

Correlation of direction of rotation, control and flow direction				
Direction of rotation	Clockwise		Counter-clockwise	
Actuation of pressure reducing valve	<b>a</b>	<b>b</b>	<b>a</b>	<b>b</b>
Control pressure	$X_1$	$X_2$	$X_1$	$X_2$
Flow direction	<b>A to B</b>	<b>B to A</b>	<b>B to A</b>	<b>A to B</b>
Working pressure	$M_B$	$M_A$	$M_A$	$M_B$

**▼ Position of ports (example)**

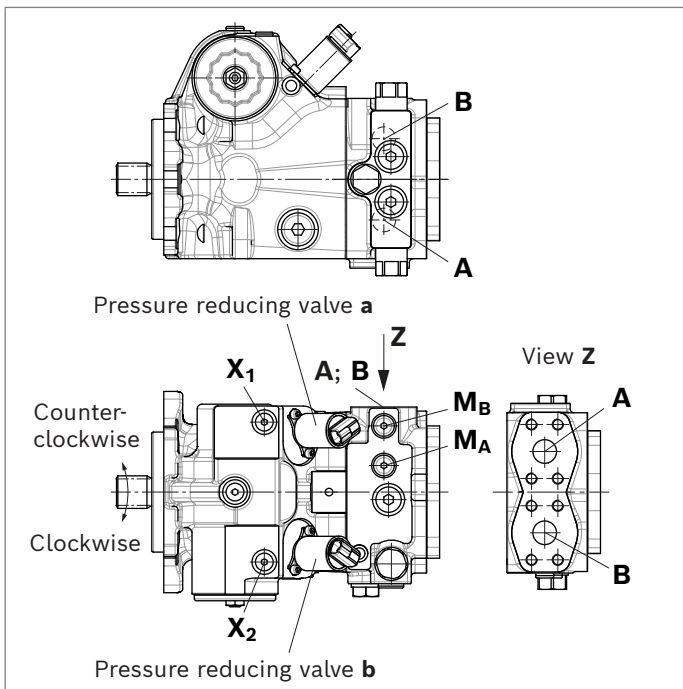

2) Minimum required oscillation range of the control current  $\Delta I_{p-p}$  (peak to peak) within the respective control range (start of control to end of control)

**Dimensions, size 56**

**ETA/ETB – Electronic control, direct operated, prepared for BODAS Software**

Standard: Working port **A** and **B**, same side left, suction port **S** bottom (20)

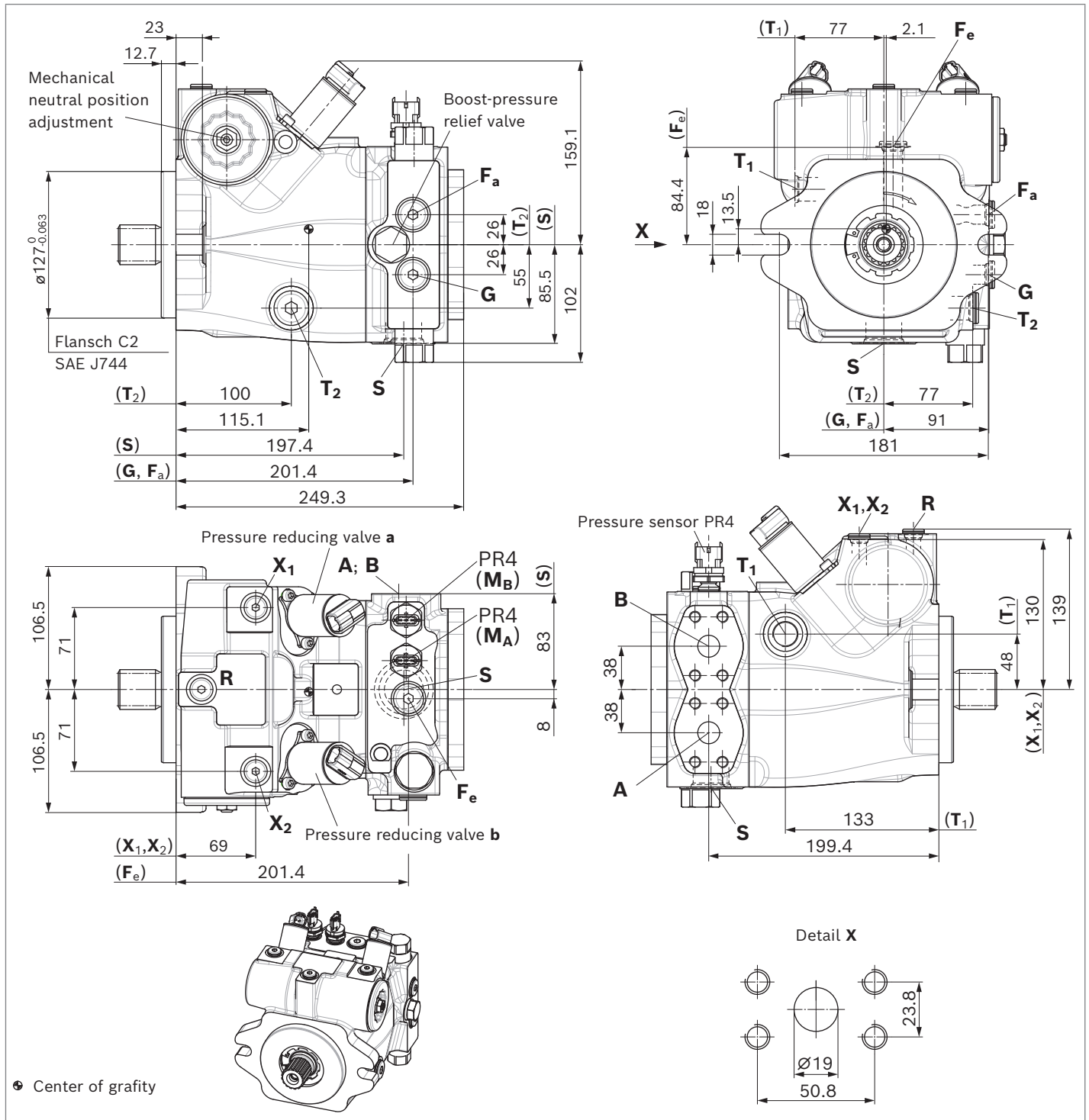

**Notice**  
 Option: Working port **A** and **B**, same side right, suction port **S** bottom (21), installation drawing on request

▼ **Splined shaft ANSI B92.1a**

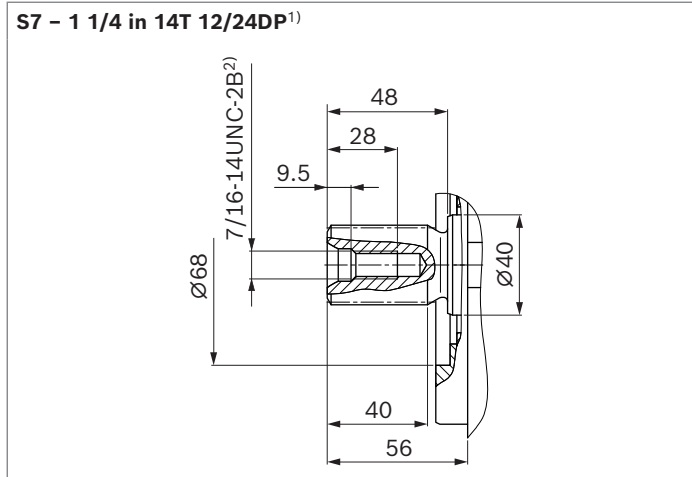

▼ **Splined shaft ANSI B92.1a**

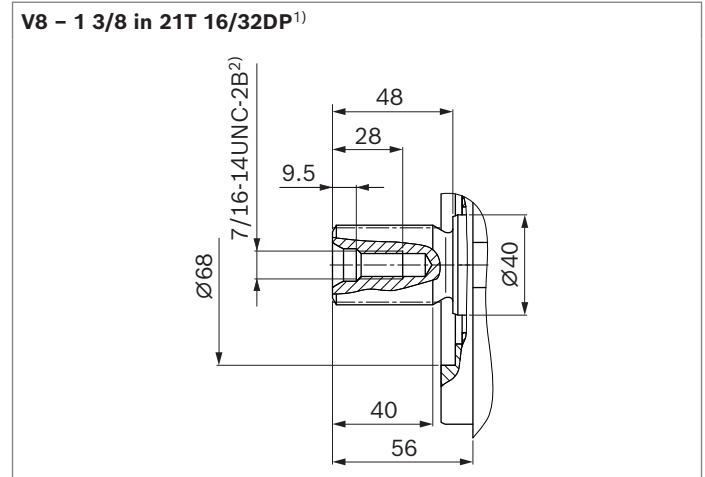

▼ **Splined shaft DIN 5480**

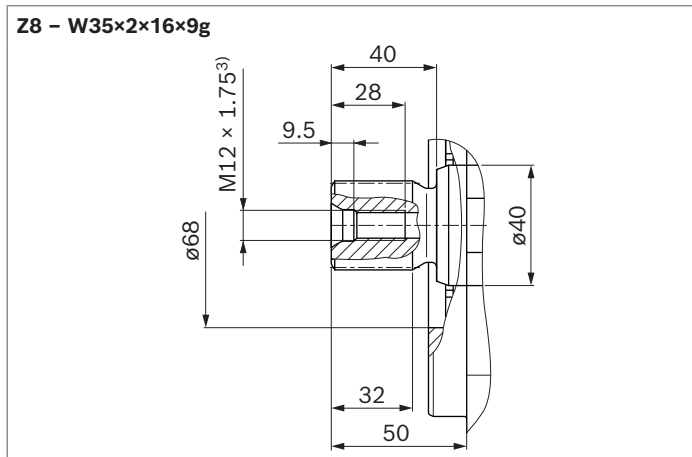

▼ **ET1/ET2- Electric control, direct operated**

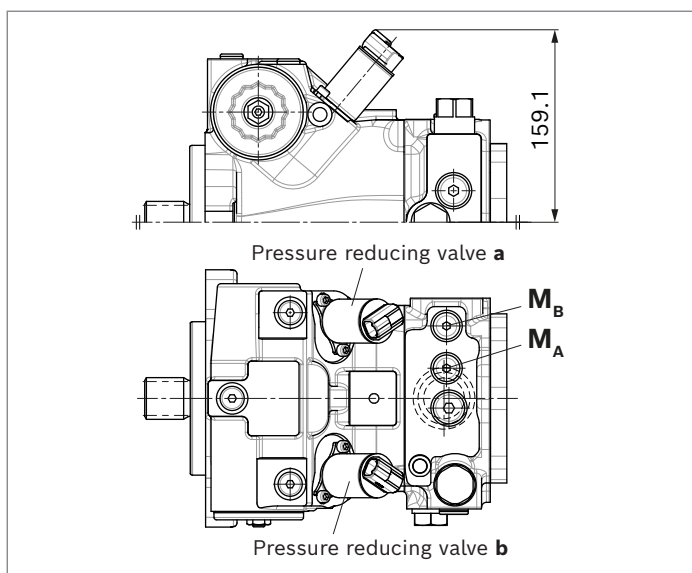

- 1) Involute spline according to ANSI B92.1a, 30° pressure angle, flat root, side fit, tolerance class 5
- 2) Thread according to ASME B1.1
- 3) Center bore according to DIN 332 (thread according to DIN 13)

Ports version "M", metric		Standard	Size	$p_{\max}$ [bar] <sup>4)</sup>	State <sup>11)</sup>
<b>A, B</b>	Working port	ISO 6162-2 <sup>5)</sup>	P19M	530	O
	Fastening thread	DIN 13	M10 × 1.5; 17 deep		
<b>S</b>	Suction port	ISO 6149	M33 × 2; 22 deep	5	O <sup>6)</sup>
<b>T<sub>1</sub></b>	Drain port	ISO 6149	M22 × 1.5; 15.5 deep	3	O <sup>7)</sup>
<b>T<sub>2</sub></b>	Drain port	ISO 6149	M22 × 1.5; 15.5 deep	3	X <sup>7)</sup>
<b>R</b>	Air bleed port	ISO 6149	M14 × 1.5; 11.5 deep	3	X
<b>X<sub>1</sub>, X<sub>2</sub></b>	Control pressure port	ISO 6149	M14 × 1.5; 11.5 deep	30	X
<b>G</b>	Boost pressure port inlet	ISO 6149	M18 × 1.5; 14.5 deep	30	X
<b>M<sub>A</sub>, M<sub>B</sub></b>	Measuring port pressure A, B	ISO 6149	M14 × 1.5; 11.5 deep	530	X <sup>8)</sup>
<b>F<sub>a</sub></b>	Boost pressure port inlet	ISO 6149	M18 × 1.5; 14.5 deep	30	X <sup>9)</sup>
<b>F<sub>e</sub></b>	Boost pressure port outlet	ISO 6149	M18 × 1.5; 14.5 deep	30	X <sup>9)</sup>

Ports version "D", ANSI, metric fastening thread		Standard	Size	$p_{\max}$ [bar] <sup>4)</sup>	State <sup>11)</sup>
<b>A, B</b>	Working port	ISO 6162-2 <sup>5)</sup>	P19M	530	O
	Fastening thread	DIN 13	M10 × 1.5; 17 deep		
<b>S</b>	Suction port	ISO 11926	1 5/16 -12 UN-2B; 20 deep	5	O <sup>6)</sup>
<b>T<sub>1</sub></b>	Drain port	ISO 11926	7/8 -14 UNF-2B; 17 deep	3	O <sup>7)</sup>
<b>T<sub>2</sub></b>	Drain port	ISO 11926	7/8 -14 UNF-2B; 17 deep	3	X <sup>7)</sup>
<b>R</b>	Air bleed port	ISO 11926	9/16 -18 UNF-2B; 13 deep	3	X
<b>X<sub>1</sub>, X<sub>2</sub></b>	Control pressure port	ISO 11926	9/16 -18 UNF-2B; 13 deep	30	X
<b>G</b>	Boost pressure port inlet	ISO 11926 <sup>10)</sup>	3/4 -16 UNF-2B; 15 deep	30	X
<b>M<sub>A</sub>, M<sub>B</sub></b>	Measuring port pressure A, B	ISO 6149	M14 x 1.5; 11.5 deep	530	X <sup>8)</sup>
<b>F<sub>a</sub></b>	Boost pressure port inlet	ISO 11926 <sup>10)</sup>	3/4 -16 UNF-2B; 15 deep	30	X <sup>9)</sup>
<b>F<sub>e</sub></b>	Boost pressure port outlet	ISO 11926	3/4 -16 UNF-2B; 15 deep	30	X <sup>9)</sup>

4) Depending on the application, momentary pressure peaks can occur. Keep this in mind when selecting measuring devices and fittings.

5) Only dimensions according to ISO 6162-2, diameter in detail X is a deviation from the standard.

6) Plugged for external boost pressure supply.

7) Depending on installation position, **T<sub>1</sub>** or **T<sub>2</sub>** must be connected (see also installation instructions on page 34).

8) Pressure sensor mounted or **M<sub>A</sub>**, **M<sub>B</sub>** plugged.

9) Must be connected for filtration in the pressure line.

10) Ports designed for straight stud ends according to ISO 11926-3 (Light-duty).

11) O = Must be connected (plugged on delivery)  
X = Plugged (in normal operation)

## Dimensions, size 71

### ETA/ETB – Electronic control, direct operated, prepared for BODAS Software

Standard: Working port **A** and **B**, same side left, suction port **S** bottom (20)

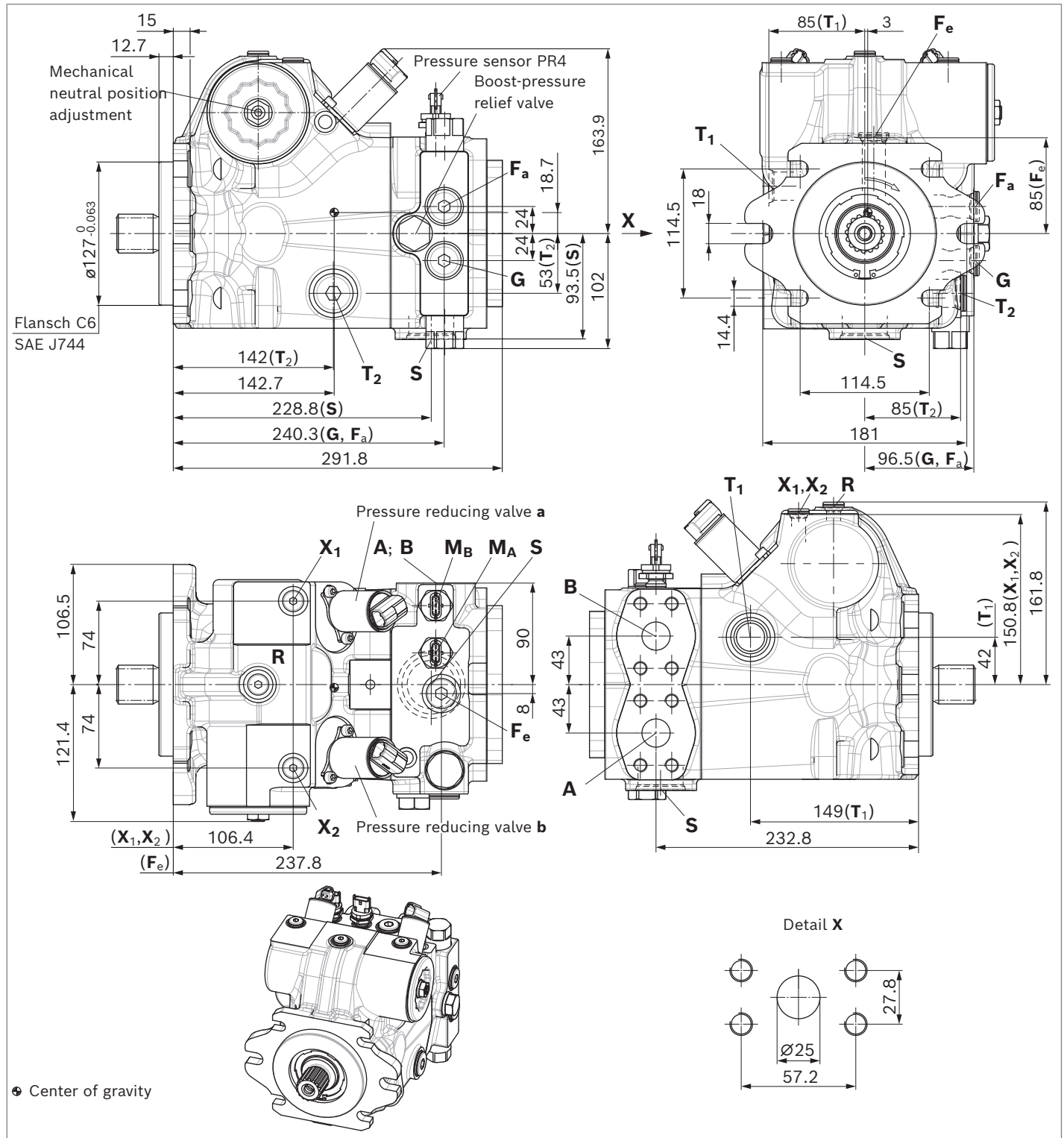

#### Notice

Option: Working port **A** and **B**, same side right, suction port **S** bottom (21), installation drawing on request

▼ **Splined shaft ANSI B92.1a**

S7 – 1 1/4 in 14T 12/24DP<sup>1)</sup>

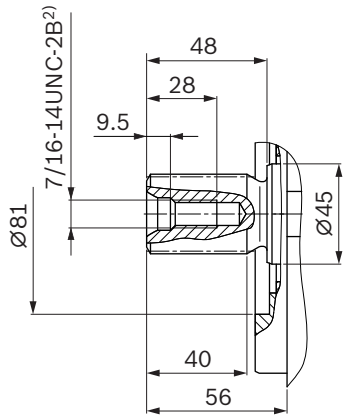

▼ **Splined shaft ANSI B92.1a**

V8 – 1 3/8 in 21T 16/32DP<sup>1)</sup>

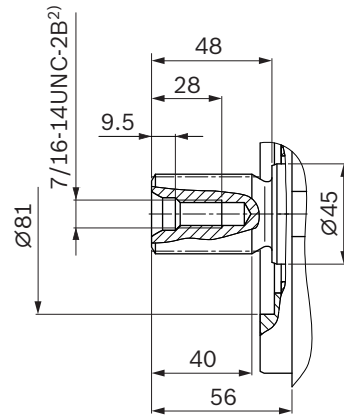

▼ **Splined shaft DIN 5480**

Z8 – W35×2×16×9g

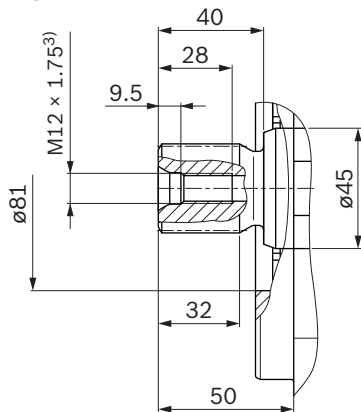

▼ **ET1/ET2- -Electronic control, direct operated**

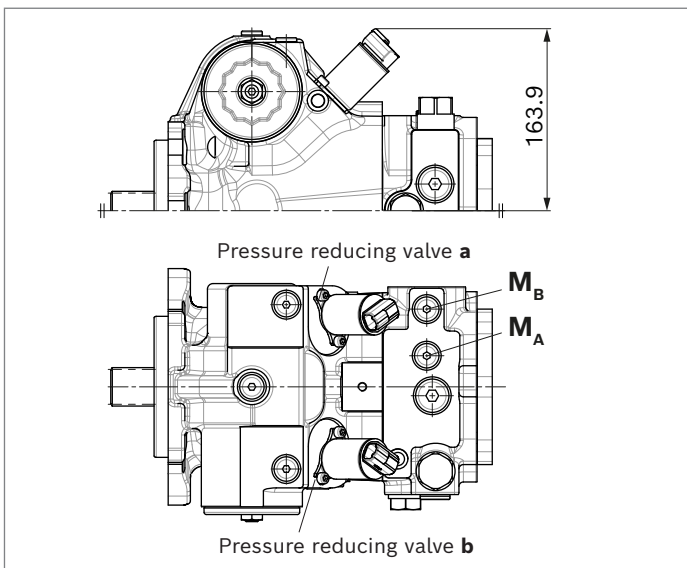

- 1) Involute spline according to ANSI B92.1a, 30° pressure angle, flat root, side fit, tolerance class 5
- 2) Thread according to ASME B1.1
- 3) Center bore according to DIN 332 (thread according to DIN 13)

Ports version "M", metric		Standard	Size	$p_{max}$ [bar] <sup>4)</sup>	State <sup>10)</sup>
<b>A, B</b>	Working port	ISO 6162-2 <sup>5)</sup>	P25M	530	O
	Fastening thread	DIN 13	M12 × 1.75; 23 deep		
<b>S</b>	Suction port	ISO 6149	M42 × 2; 20 deep	5	O <sup>6)</sup>
<b>T<sub>1</sub></b>	Drain port	ISO 6149	M27 × 2; 19 deep	3	O <sup>7)</sup>
<b>T<sub>2</sub></b>	Drain port	ISO 6149	M27 × 2; 19 deep	3	X <sup>7)</sup>
<b>R</b>	Air bleed port	ISO 6149	M14 × 1.5; 11.5 deep	3	X
<b>X<sub>1</sub>, X<sub>2</sub></b>	Control pressure port	ISO 6149	M14 × 1.5; 11.5 deep	30	X
<b>G</b>	Boost pressure port inlet	ISO 6149	M22 × 1.5; 15.5 deep	30	X
<b>M<sub>A</sub>, M<sub>B</sub></b>	Measuring port pressure A, B	ISO 6149	M14 × 1.5; 11.5 deep	530	X <sup>8)</sup>
<b>F<sub>a</sub></b>	Boost pressure port inlet	ISO 6149	M22 × 1.5; 15.5 deep	30	X <sup>9)</sup>
<b>F<sub>e</sub></b>	Boost pressure port outlet	ISO 6149	M22 × 1.5; 15.5 deep	30	X <sup>9)</sup>

Ports version "D", ANSI, metric fastening thread		Standard	Size	$p_{max}$ [bar] <sup>4)</sup>	State <sup>10)</sup>
<b>A, B</b>	Working port	ISO 6162-2 <sup>5)</sup>	P25M	530	O
	Fastening thread	DIN 13	M12 × 1.75; 23 deep		
<b>S</b>	Suction port	ISO 11926	1 5/8 -12 UN-2B; 20 deep	5	O <sup>6)</sup>
<b>T<sub>1</sub></b>	Drain port	ISO 11926	1 1/16 -12 UN-2B; 20 deep	3	O <sup>7)</sup>
<b>T<sub>2</sub></b>	Drain port	ISO 11926	1 1/16 -12 UN-2B; 20 deep	3	X <sup>7)</sup>
<b>R</b>	Air bleed port	ISO 11926	9/16 -18 UNF-2B; 13 deep	3	X
<b>X<sub>1</sub>, X<sub>2</sub></b>	Control pressure port	ISO 11926	9/16 -18 UNF-2B; 13 deep	30	X
<b>G</b>	Boost pressure port inlet	ISO 11926 <sup>10)</sup>	7/8 -14 UNF-2B; 17 deep	30	X
<b>M<sub>A</sub>, M<sub>B</sub></b>	Measuring port pressure A, B	ISO 6149	M14 × 1.5; 11.5 deep	530	X <sup>8)</sup>
<b>F<sub>a</sub></b>	Boost pressure port inlet	ISO 11926 <sup>10)</sup>	7/8 -14 UNF-2B; 17 deep	30	X <sup>9)</sup>
<b>F<sub>e</sub></b>	Boost pressure port outlet	ISO 11926	7/8 -14 UNF-2B; 17 deep	30	X <sup>9)</sup>

4) Depending on the application, momentary pressure peaks can occur. Keep this in mind when selecting measuring devices and fittings.

5) Only dimensions according to ISO 6162-2, diameter in detail X is a deviation from the standard.

6) Plugged for external boost pressure supply.

7) Depending on installation position, **T<sub>1</sub>** or **T<sub>2</sub>** must be connected (see also installation instructions on page 34).

8) Pressure sensor mounted or **M<sub>A</sub>, M<sub>B</sub>** plugged.

9) Must be connected for filtration in the pressure line.

10) Ports designed for straight stud ends according to ISO 11926-3 (Light-duty).

11) O = Must be connected (plugged on delivery)

X = Plugged (in normal operation)

**Dimensions, size 90**

**ETA/ETB – Electronic control, direct operated, prepared for BODAS Software**

Standard: Working port **A** and **B**, same side left, suction port **S** bottom (20)

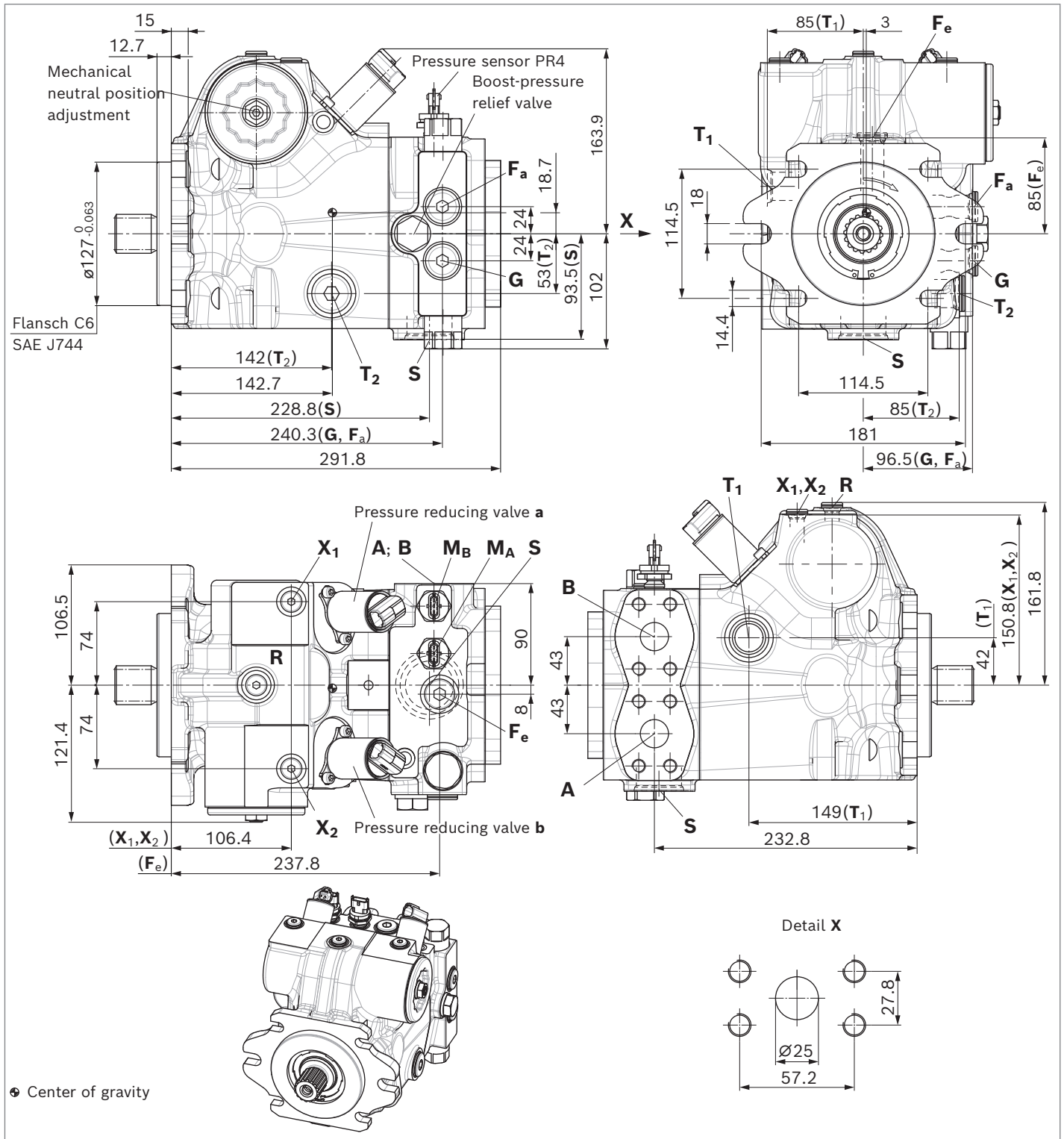

**Notice**  
 Option: Working port **A** and **B**, same side right, suction port **S** bottom (21), installation drawing on request

▼ **Splined shaft ANSI B92.1a**

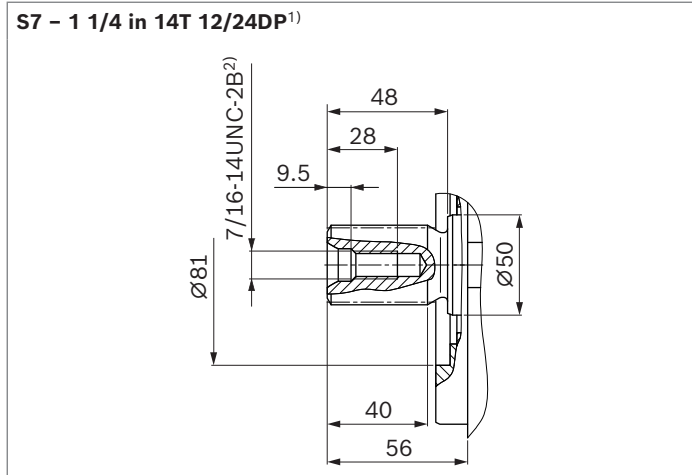

▼ **Splined shaft ANSI B92.1a**

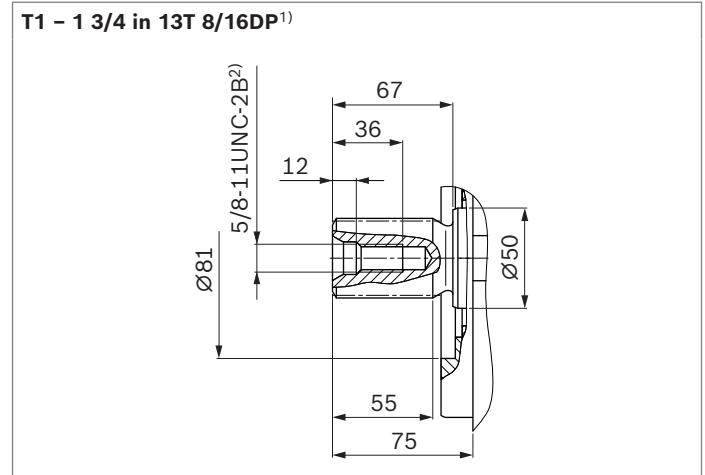

▼ **Splined shaft DIN 5480**

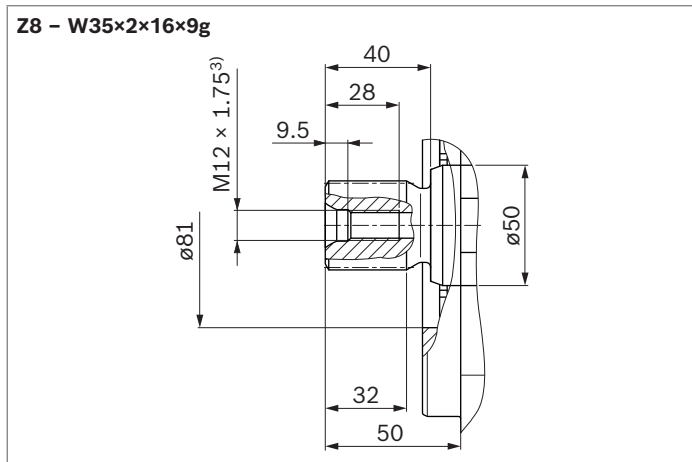

▼ **ET1/ET2- Electric control, direct operated**

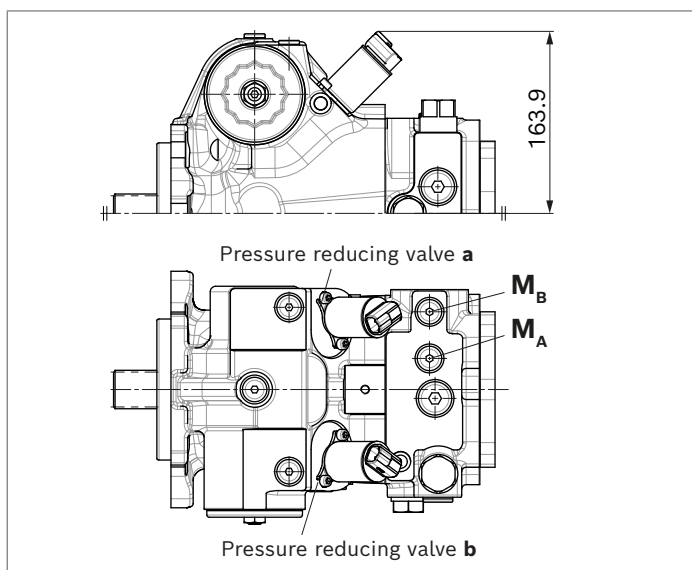

- 1) Involute spline according to ANSI B92.1a, 30° pressure angle, flat root, side fit, tolerance class 5
- 2) Thread according to ASME B1.1
- 3) Center bore according to DIN 332 (thread according to DIN 13)

Ports version "M", metric		Standard	Size	$p_{\max}$ [bar] <sup>4)</sup>	State <sup>10)</sup>
<b>A, B</b>	Working port	ISO 6162-2 <sup>5)</sup>	P25M	530	O
	Fastening thread	DIN 13	M12 x 1.75; 23 deep		
<b>S</b>	Suction port	ISO 6149	M42 x 2; 20 deep	5	O <sup>6)</sup>
<b>T<sub>1</sub></b>	Drain port	ISO 6149	M27 x 2; 19 deep	3	O <sup>7)</sup>
<b>T<sub>2</sub></b>	Drain port	ISO 6149	M27 x 2; 19 deep	3	X <sup>7)</sup>
<b>R</b>	Air bleed port	ISO 6149	M14 x 1.5; 11.5 deep	3	X
<b>X<sub>1</sub>, X<sub>2</sub></b>	Control pressure port	ISO 6149	M14 x 1.5; 11.5 deep	30	X
<b>G</b>	Boost pressure port inlet	ISO 6149	M22 x 1.5; 15.5 deep	30	X
<b>M<sub>A</sub>, M<sub>B</sub></b>	Measuring port pressure A, B	ISO 6149	M14 x 1.5; 11.5 deep	530	X <sup>8)</sup>
<b>F<sub>a</sub></b>	Boost pressure port inlet	ISO 6149	M22 x 1.5; 15.5 deep	30	X <sup>9)</sup>
<b>F<sub>e</sub></b>	Boost pressure port outlet	ISO 6149	M22 x 1.5; 15.5 deep	30	X <sup>9)</sup>

Ports version "D", ANSI, metric fastening thread		Standard	Size	$p_{\max}$ [bar] <sup>4)</sup>	State <sup>10)</sup>
<b>A, B</b>	Working port	ISO 6162-2 <sup>5)</sup>	P25M	530	O
	Fastening thread	DIN 13	M12 x 1.75; 23 deep		
<b>S</b>	Suction port	ISO 11926	1 5/8 -12 UN-2B; 20 deep	5	O <sup>6)</sup>
<b>T<sub>1</sub></b>	Drain port	ISO 11926	1 1/16 -12 UN-2B; 20 deep	3	O <sup>7)</sup>
<b>T<sub>2</sub></b>	Drain port	ISO 11926	1 1/16 -12 UN-2B; 20 deep	3	X <sup>7)</sup>
<b>R</b>	Air bleed port	ISO 11926	9/16 -18 UNF-2B; 13 deep	3	X
<b>X<sub>1</sub>, X<sub>2</sub></b>	Control pressure port	ISO 11926	9/16 -18 UNF-2B; 13 deep	30	X
<b>G</b>	Boost pressure port inlet	ISO 11926 <sup>10)</sup>	7/8 -14 UNF-2B; 17 deep	30	X
<b>M<sub>A</sub>, M<sub>B</sub></b>	Measuring port pressure A, B	ISO 6149	M14 x 1.5; 11.5 deep	530	X <sup>8)</sup>
<b>F<sub>a</sub></b>	Boost pressure port inlet	ISO 11926 <sup>10)</sup>	7/8 -14 UNF-2B; 17 deep	30	X <sup>9)</sup>
<b>F<sub>e</sub></b>	Boost pressure port outlet	ISO 11926	7/8 -14 UNF-2B; 17 deep	30	X <sup>9)</sup>

4) Depending on the application, momentary pressure peaks can occur. Keep this in mind when selecting measuring devices and fittings.

5) Only dimensions according to ISO 6162-2, diameter in detail X is a deviation from the standard.

6) Plugged for external boost pressure supply.

7) Depending on installation position, **T<sub>1</sub>** or **T<sub>2</sub>** must be connected (see also installation instructions on page 34).

8) Pressure sensor mounted or **M<sub>A</sub>**, **M<sub>B</sub>** plugged.

9) Must be connected for filtration in the pressure line.

10) Ports designed for straight stud ends according to ISO 11926-3 (Light-duty).

11) O = Must be connected (plugged on delivery)  
X = Plugged (in normal operation)

## Dimensions, through-drive

Flange SAE J744 <sup>1)</sup>			Hub for splined shaft <sup>2)</sup>			56	71	90	
Diameter	Mounting <sup>3)</sup>	Code	Diameter		Code				
Without through drive									
82-2 (A)	$\text{⌀}$	A1	5/8 in	9T 16/32DP	S2	●	●	●	0000
	$\text{∞}$	A2	5/8 in	9T 16/32DP	S2	●	●	●	A1S2
						●	●	●	A2S2

### ▼ Without through drive

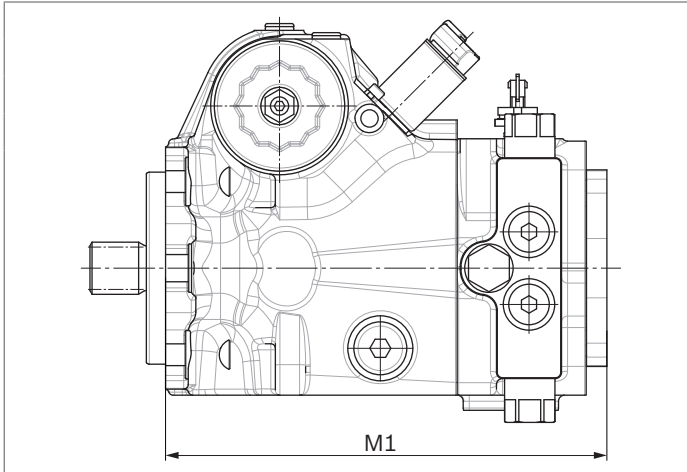

NG	M1
56	249.3
71	291.8
90	291.8

### ▼ A1S2, A2S2 (with boost pump)

Flange SAE J744: 82-2 (A)

Hub for splined shaft: 5/8 in 9T 16/32DP<sup>2)</sup>

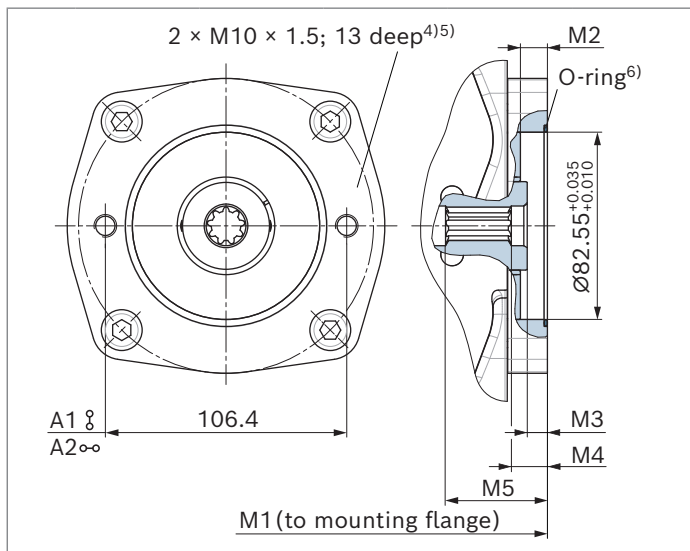

### ▼ A1S2, A2S2 (without boost pump)

Flange SAE J744: 82-2 (A)

Hub for splined shaft: 5/8 in 9T 16/32DP<sup>2)</sup>

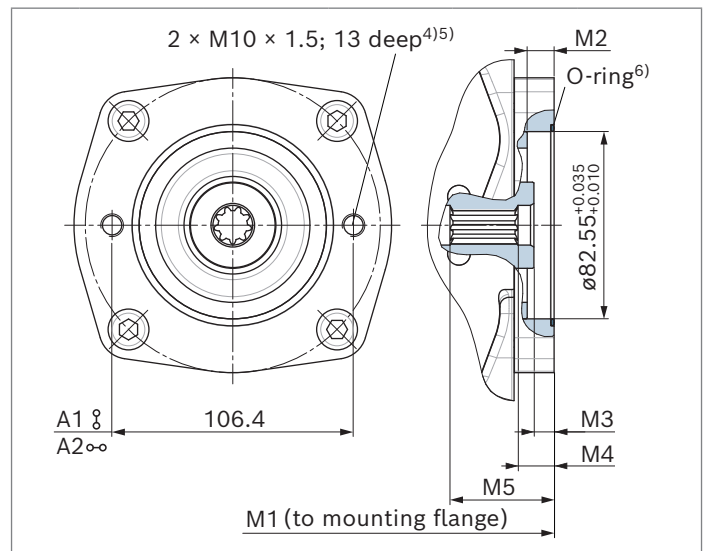

NG	M1	M2	M3	M4	M5
56	253.3	11.9	8.9	15.9	44.9
71	295.8	11.9	8.4	15.4	45.2
90	295.8	11.9	8.4	8.4	32.1

NG	M1	M2	M3	M4	M5
56	253.3	11.85	8.9	15.9	44.9
71	295.8	11.85	8.4	15.6	45.2
90	295.8	11.85	8.4	8.4	32.1

1) The through-drive flange is only supplied with a metric fastening thread.

2) Involute spline according to ANSI B92.1a, 30° pressure angle, flat root, side fit, tolerance class 5

3) Mounting holes pattern viewed on through drive with control at top

4) Design according to VDI 2230 with  $\mu = 0.1$  for screw quality 8.8

5) Thread according to DIN 13

6) O-ring included in the scope of delivery

Flange SAE J744 <sup>1)</sup>			Hub for splined shaft <sup>2)</sup>			56	71	90	
Diameter	Mounting <sup>3)</sup>	Code	Diameter		Code				
101-2 (B)	⌀	B1	7/8 in	13T 16/32DP	S4	●	●	●	<b>B1S4</b>
		B1	1 in	15T 16/32DP	S5	●	●	●	<b>B1S5</b>
	∞	B2	7/8 in	13T 16/32DP	S4	●	●	●	<b>B2S4</b>
		B2	1 in	15T 16/32DP	S5	●	●	●	<b>B2S5</b>

▼ **B1S4, B2S4, ( with boost pump)**

Flange SAE J744: 101-2 (B)

Hub for splined shaft: 7/8 in 13T 16/32DP<sup>2)</sup>

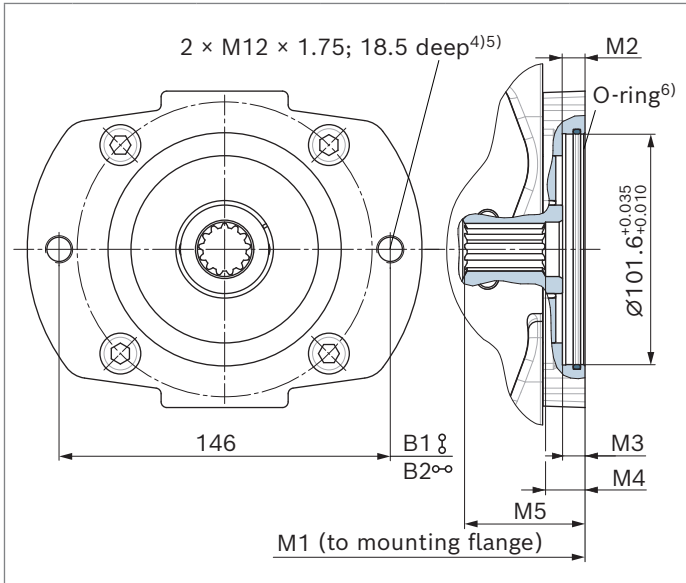

NG	M1	M2	M3	M4	M5
<b>56</b>	254.3	12.9	9.9	17.4	53.9
<b>71</b>	296.8	10	8.4	14.9	38.4
<b>90</b>	296.8	10	9	15	43

▼ **B1S4, B2S4, ( without boost pump)**

Flange SAE J744: 101-2 (B)

Hub for splined shaft: 7/8 in 13T 16/32DP<sup>2)</sup>

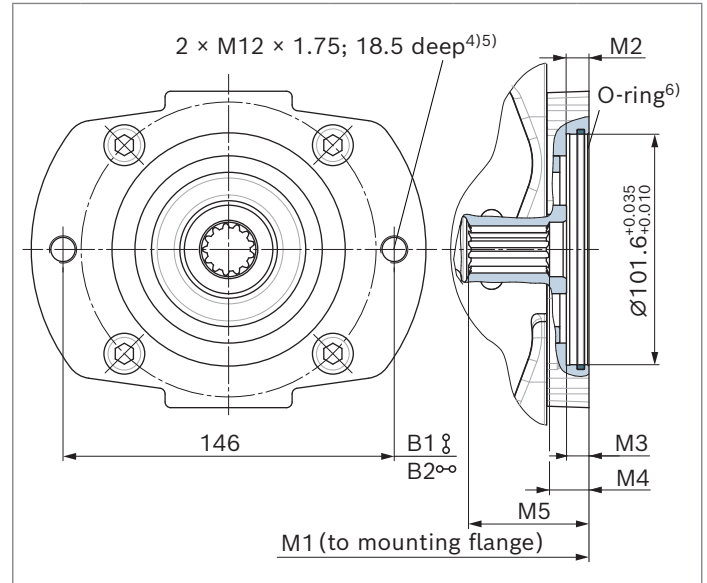

NG	M1	M2	M3	M4	M5
<b>56</b>	254.3	10	9.9	17.4	52
<b>71</b>	296.8	10	8.9	11.9	38.9
<b>90</b>	296.8	10	9	15	43

1) The through-drive flange is only supplied with a metric fastening thread.  
 2) Involute spline according to ANSI B92.1a, 30° pressure angle, flat root, side fit, tolerance class 5

3) Mounting holes pattern viewed on through drive with control at top  
 4) Design according to VDI 2230 with  $\mu = 0.1$  for screw quality 8.8  
 5) Thread according to DIN 13  
 6) O-ring included in the scope of delivery

Flange SAE J744 <sup>1)</sup>			Hub for splined shaft <sup>2)</sup>			56	71	90	
Diameter	Mounting <sup>3)</sup>	Code	Diameter		Code				
101-2 (B)	⌀	B1	7/8 in	13T 16/32DP	S4	●	●	●	<b>B1S4</b>
		B1	1 in	15T 16/32DP	S5	●	●	●	<b>B1S5</b>
	∞	B2	7/8 in	13T 16/32DP	S4	●	●	●	<b>B2S4</b>
		B2	1 in	15T 16/32DP	S5	●	●	●	<b>B2S5</b>

▼ **B1S5, B2S5 (with boost pump)**

Flange SAE J744: 101-2 (B)

Hub for splined shaft: 1 in 15T 16/32DP<sup>2)</sup>

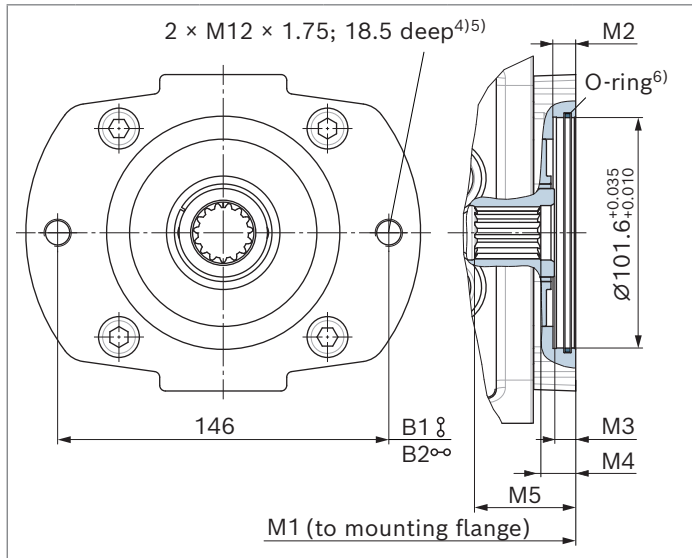

NG	M1	M2	M3	M4	M5
<b>56</b>	254.3	10	9.9	17.9	41.9
<b>71</b>	296.8	10	8.4	14.4	50.4
<b>90</b>	296.8	10	9	14	49

▼ **B1S5, B2S5 (without boost pump)**

Flange SAE J744: 101-2 (B)

Hub for splined shaft: 1 in 15T 16/32DP<sup>2)</sup>

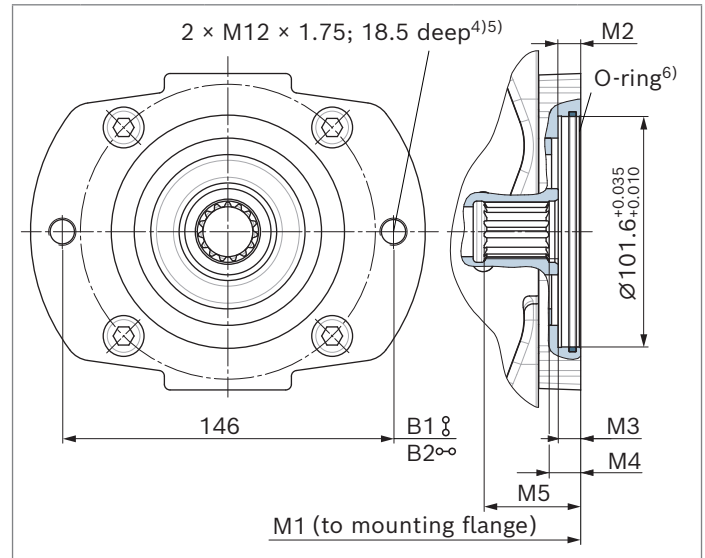

NG	M1	M2	M3	M4	M5
<b>56</b>	254.3	10	9.9	13.9	41.4
<b>71</b>	296.8	10	8.4	14.4	50.4
<b>90</b>	296.8	10	9	14	49

1) The through-drive flange is only supplied with a metric fastening thread.

2) Involute spline according to ANSI B92.1a, 30° pressure angle, flat root, side fit, tolerance class 5

3) Mounting holes pattern viewed on through drive with control at top

4) Design according to VDI 2230 with  $\mu = 0.1$  for screw quality 8.8

5) Thread according to DIN 13

6) O-ring included in the scope of delivery

Flange SAE J744 <sup>1)</sup>		Hub for splined shaft <sup>2)</sup>			56	71	90
Diameter	Mounting <sup>3)</sup>	Code	Diameter	Code			
127-2/4 (C)		C6	1 1/4 in 14T 12/24DP	S7	•	•	•
		C9	1 1/4 in 14T 12/24DP	S7	•	•	•

▼ **C6S7, C9S7<sup>3)</sup> (with boost pump)**

Flange SAE J744: 127-2/4 (C)

Hub for splined shaft: 1 1/4 in 14T 12/24DP<sup>2)</sup>

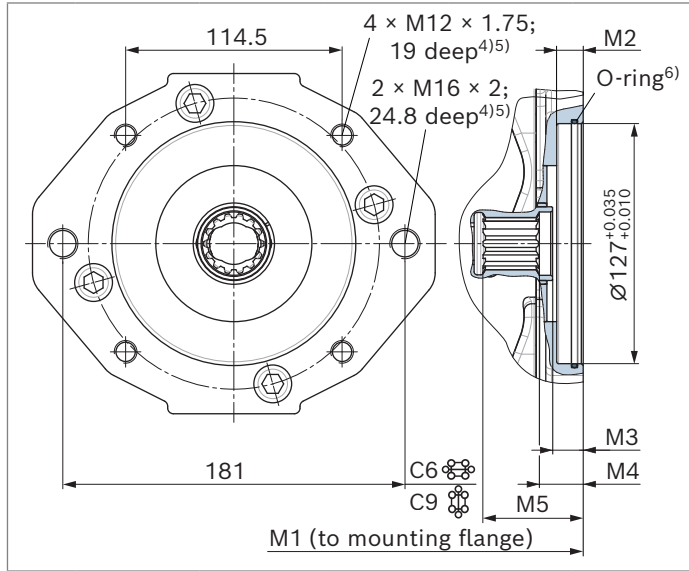

NG	M1	M2	M3	M4	M5
56	260.6	14	16.2	23.2	51.7
71	303.1	14	14.7	21.2	54.7
90	303.1	14	13.7	16.2	51.2

▼ **C6S7, C9S7<sup>3)</sup> (without boost pump)**

Flange SAE J744: 127-2/4 (C)

Hub for splined shaft: 1 1/4 in 14T 12/24DP<sup>2)</sup>

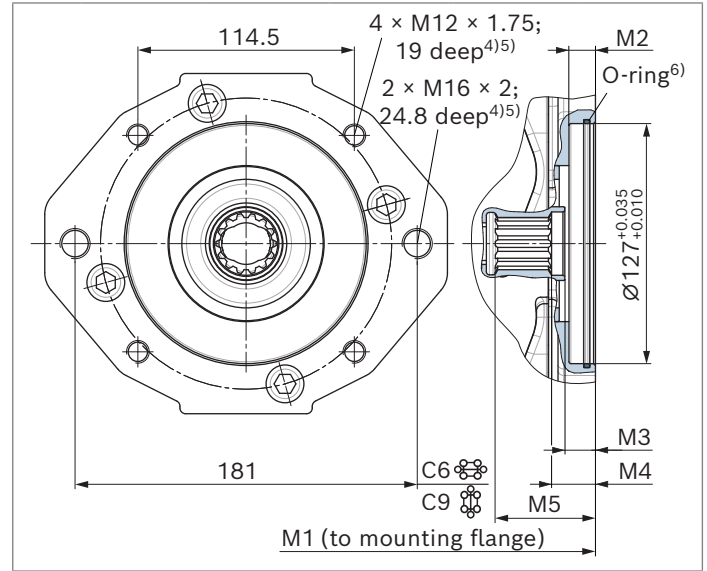

NG	M1	M2	M3	M4	M5
56	260.6	14	16.2	23.2	51.7
71	303.1	14	15.2	21.7	55.2
90	303.1	14	13.7	16.7	49.5

1) The through-drive flange is only supplied with a metric fastening thread.  
2) Involute spline according to ANSI B92.1a, 30° pressure angle, flat root, side fit, tolerance class 5

3) Mounting holes pattern viewed on through drive with control at top  
4) Design according to VDI 2230 with  $\mu = 0.1$  for screw quality 8.8  
5) Thread according to DIN 13  
6) O-ring included in the scope of delivery

## Overview of mounting options

Through drive <sup>1)</sup>			Mounting options – 2nd pump			
Flange	Hub for splined shaft	Code	A4VG/35 NG (shaft)	A4VG/32 NG (shaft)	A10VG/10 NG (shaft)	External gear pump <sup>2)</sup>
82-2 (A)	5/8 in	<b>A_S2</b>	–	–	–	AZPF, AZPS NG4 ... 28, AZPW NG5 ... 22
101-2 (B)	7/8 in	<b>B_S4</b>	–	–	18 (S)	AZPN-11 NG20 ... 25, AZPG-22 NG28 ... 100
	1 in	<b>B_S5</b>	–	28 (S)	28, 45 (S)	–
127-2 (C)	1 1/4 in	<b>C_S7</b>	56, 71, 90 (S7)	40, 56, 71 (S)	63 (S)	–
127-4 (C)	1 1/4 in	<b>C_S7</b>	71, 90 (S7)	71 (S)	–	–

Through drive <sup>1)</sup>			Mounting options – 2nd pump				
Flange	Hub for splined shaft	Code	A10V(S)O/31 NG (shaft)	A10VO/32 NG (shaft)	A10V(S)O/5x NG (shaft)	A11VO/1x NG (shaft)	A1VO/10 NG (shaft)
82-2 (A)	5/8 in	<b>A_S2</b>	–	–	10, 18 (U)	–	–
101-2 (B)	7/8 in	<b>B_S4</b>	28 (S) 45 (U)	45 (U)	28 (S) 45 (U)	–	35 (S4)
	1 in	<b>B_S5</b>	45 (S)	45 (S)	45 (S) 60, 63, 72 (U)	40 (S)	35 (S5)
127-2 (C)	1 1/4 in	<b>C_S7</b>	71, 88 (S) 100 (U)	71 (S) 100 (U)	85, 100 (U)	–	–
127-4 (C)	1 1/4 in	<b>C_S7</b>	–	71 (S)	60, 63, 72 (S) 85, 100 (U)	60 (S)	–

### Notice

The mounting options listed only apply for drive shaft versions with undercut. Please contact us for drive shafts without undercut.

1) Availability of the individual sizes, see type code on page 3.

2) Bosch Rexroth recommends special versions of the gear pumps. Please contact us.

**Combination pumps A4VG + A4VG****Total length A**

A4VG	A4VG 2nd pump <sup>1)</sup>		
1st pump	NG056	NG071	NG090
<b>NG056</b>	509.9	–	–
<b>NG071</b>	552.4	594.9	–
<b>NG090</b>	552.4	594.9	594.9

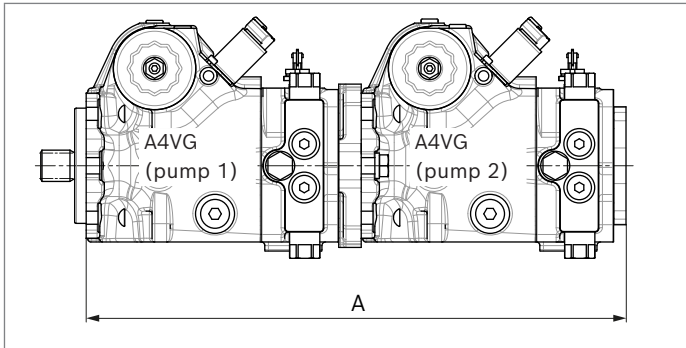

By using combination pumps, it is possible to have independent circuits without the need for splitter gearboxes.

When ordering combination pumps the type designations for the 1st and the 2nd pump must be linked by a "+".

Order example:

**A4VG090ET20P/35MRNC6T1-20GC6S7AS400-0 + A4VG071ET20P/35MRNC6S720G0000AS400-0**

A tandem pump, with two pumps of equal size, is permissible without additional supports, assuming that the dynamic mass acceleration does not exceed maximum 10 g (= 98.1 m/s<sup>2</sup>).

From size 71, the 4-hole mounting flange must be used for mounting the 1st pump.

For combination pumps consisting of more than two pumps, the mounting flange must be rated for the permissible moment of inertia, please contact us.

**Notice**

- ▶ The combination pump type code is shown in shortened form in the order confirmation.
- ▶ The permissible through-drive torques are to be observed (see page 9).

<sup>1)</sup> 2nd pump without through drive

## High-pressure relief valves

The two high-pressure relief valves protect the hydrostatic gear (pump and motor) from overloading. They limit the maximum pressure in the respective high-pressure line and serve simultaneously as boost valves.

The high-pressure relief valves are exclusively intended to protect the system from high-pressure peaks until the control dynamics of the pressure cut-off ensure the intended maximum working pressure.

An electronic pressure cut-off must be provided for permanent high pressure limitation.

The hydrostatic gear must be designed in such a way that a longer response of the high-pressure relief valves (> 0.3 sec.) is prevented. The volume of 70 l/min must not be exceeded during the valve phase.

### Setting ranges

High-pressure relief valve, direct operated	Differential pressure setting $\Delta p_{HD}$
Setting	320 bar
	400 bar
	420 bar
	440 bar
	470 bar
	500 bar

### Settings on high-pressure relief valve A and B

Differential pressure setting	$\Delta p_{HD} = \dots$ bar
Test pressure of the HD valve (at $q_{V1}$ )	$p_{max} = \dots$ bar ( $p_{max} = \Delta p_{HD} + p_{Sp}$ )

The valve settings are set to be size-independent at a theoretical flow of approx. 70 l/min at  $V_{g \max}$  ( $q_{V1}$ ). There may be deviations with other operating parameters.

### ▼ Circuit diagram

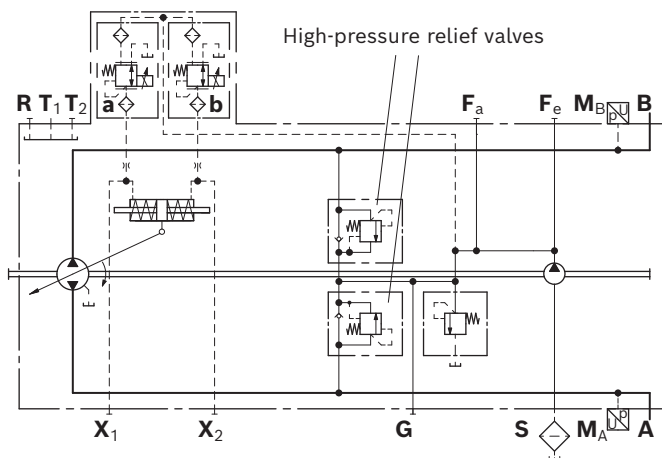

### Example: $\Delta p$ drive design = 470 bar ( $p_{A, B} - p_{Sp}$ )

Max. working pressure $p_{A, B}$	-	Boost pressure $p_{Sp}$	+	Safety	=	Differential pressure $\Delta p_{HD}$
495 bar	-	25 bar	+	30 bar	=	500 bar

- ▶ Test pressure of the HD valve (at  $q_{V1}$ ):  
 $p_{max} = 525$  bar ( $p_{max} = \Delta p_{HD} + p_{Sp}$ )

### ▼ Setting diagram

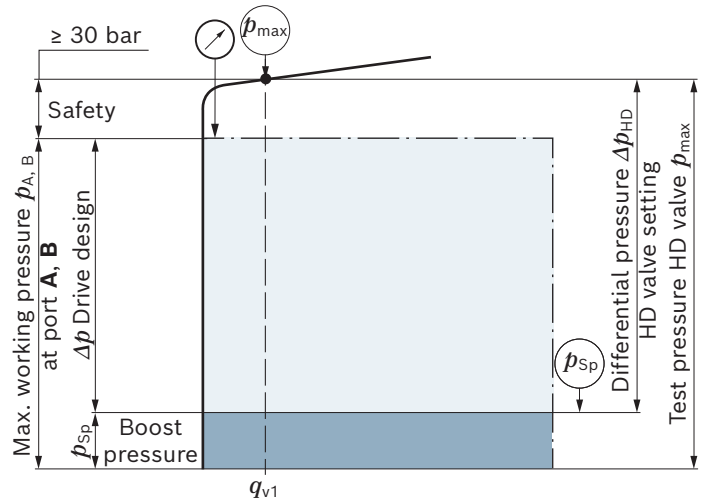

### Key

HD valve	High-pressure relief valve
Test pressure HD valve $p_{max}$	The plant-set pressure value set at $q_{V1}$
Differential pressure HD valve $\Delta p_{HD}$	Test pressure HD valve (abs.) minus the boost pressure setting
Maximum working pressure $p_{A, B}$	The overall design of the hydrostatic drive is based on the maximum working pressure $p_{A, B}$ . It comprises the boost pressure setting and the $\Delta p$ design.
$\Delta p$ Drive design	Differential pressure value determining the available torque at the hydraulic motor ( $p_{A, B} - p_{Sp}$ ).
Boost pressure $p_{Sp}$	Boost pressure setting of the boost-pressure relief valve
Safety	Required distance between maximum working pressure (and/or pressure cut-off) and test pressure of the high-pressure relief valve to prevent constant response of the high-pressure relief valves at maximum working pressure.

### Notice

Upon response of the high-pressure relief valve, the permissible temperature and viscosity must be complied with.

**Option: Bypass function**

A connection between the two high-pressure passages **A** and **B** can be established using the bypass function (e.g. for machine towing).

► Towing speed

The maximum towing speed depends on the gear ratio in the vehicle and must be calculated by the vehicle manufacturer. The corresponding flow of  $q_v = 30$  l/min may not be exceeded.

► Towing distance

Only tow the vehicle out of the immediate danger zone.

For further information on the bypass function, see the instruction manual.

**Notice**

The bypass function is not illustrated in the circuit diagrams.

## Filtration in the boost pump suction line

### Version S

Filter version	Suction filter
Recommendation	With contamination indicator, with bypass
Recommended flow resistance at filter element	
At $v = 30 \text{ mm}^2/\text{s}$ , $n = n_{\text{max}}$	$\Delta p = 0.1 \text{ bar}$
At $v = 1000 \text{ mm}^2/\text{s}$ , $n = n_{\text{max}}$	$\Delta p = 0.3 \text{ bar}$
Pressure at suction port S	
Continuous $p_{S \text{ min}}$ ( $v \leq 30 \text{ mm}^2/\text{s}$ )	$\geq 0.8 \text{ bar absolute}$
Short-term, at a cold start ( $t < 3 \text{ min}$ )	$\geq 0.5 \text{ bar absolute}$
Maximum pressure $p_{S \text{ max}}$	$\leq 5 \text{ bar absolute}$

Use of version S is preferred.

The suction filter is not included in the scope of delivery.

#### ▼ Circuit diagram

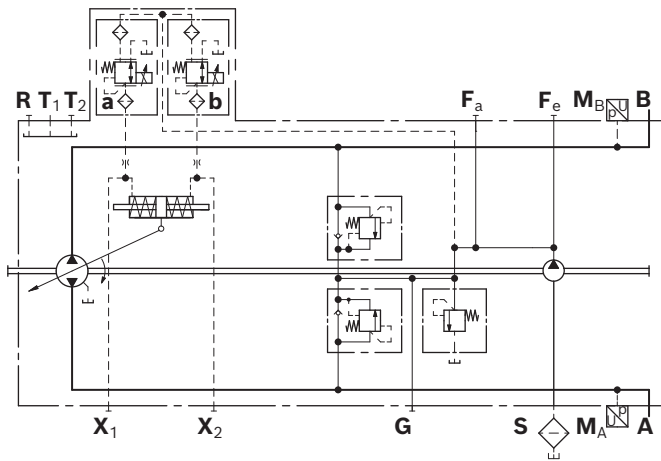

## Filtration in the boost pump pressure line

### Version D

#### Ports for external boost circuit filtration

Ports	
Boost pressure inlet	Port $F_a$
Boost pressure outlet	Port $F_e$
Filter version	Boost pressure filter
Recommendation	With contamination indicator, with cold start valve
Filter arrangement	Separate in the pressure line (inline filter)

The boost pressure filter is not included in the scope of delivery.

#### Notice

- Filters with a bypass are not recommended. Please contact us for applications with a bypass.
- The pressure drop at the filter is viscosity- and contamination-dependent. Note the maximum permissible pressure of the boost pump in combination with the set feed pressure.

#### ▼ Circuit diagram

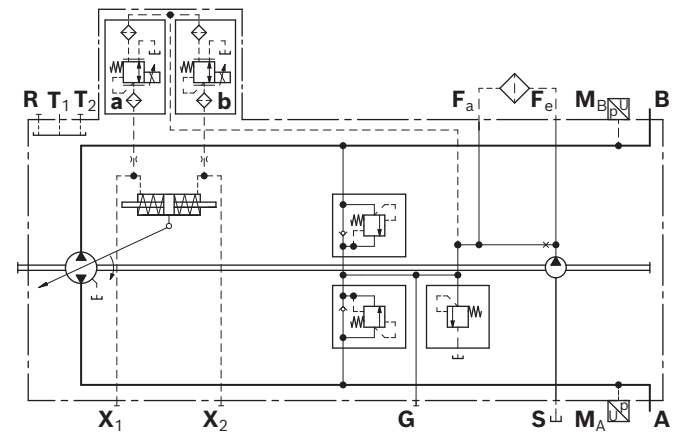

## External boost pressure supply

### Version E

This variant should be used in versions without integrated boost pump (**U**).

Port **S** is plugged.

The boost pressure supply comes from port **G**.

The filter should be installed separately on port **G** before the boost pressure supply.

To ensure functional reliability, maintain the required cleanliness level for the boost pressure fluid fed in at port **G** (see page 5).

### ▼ Circuit diagram

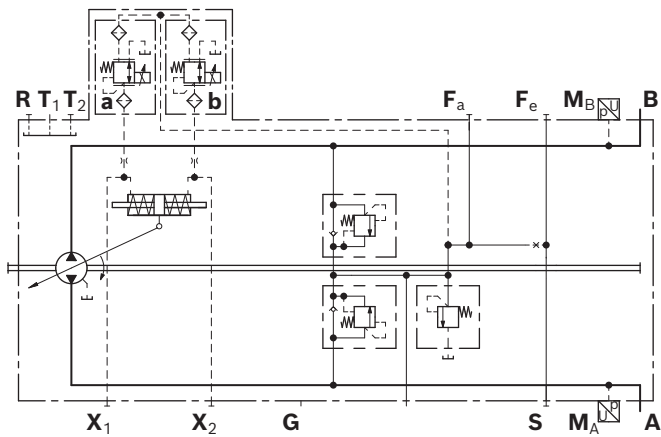

## Boost-pressure relief valve

The boost-pressure relief valve is used to limit the boost pressure level. It limits the boost pressure depending on the case pressure.

### Setting range

Boost-pressure relief valve	Differential pressure setting $p_{St}$ ( $p_{Sp} = \Delta p_{Sp} + p_T$ )
Standard value	25 bar
Optional values	27 bar 30 bar

The valve settings are performed at  $n = 2000$  rpm.

There may be deviations in the set pressures with other operating parameters.

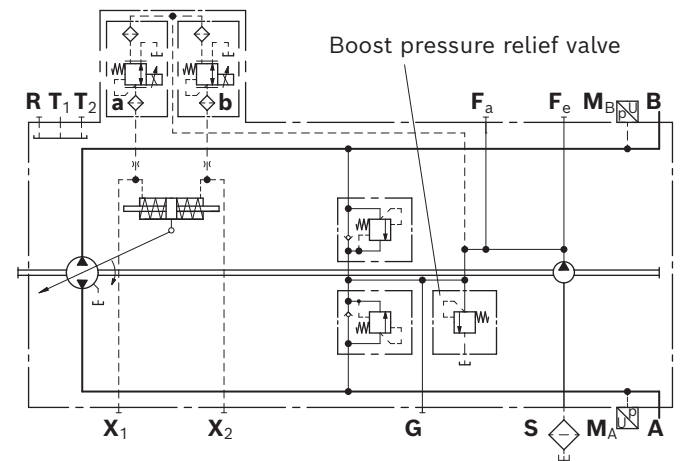

## Connector for the pressure reducing valve

### DEUTSCH DT04-2P-EP04

Molded, 2-pin

The following type of protection ensues with the installed mating connector:

- ▶ IP6K5 (ISO 20653) and
- ▶ IP6K9K (ISO 20653)

#### ▼ Switching symbol

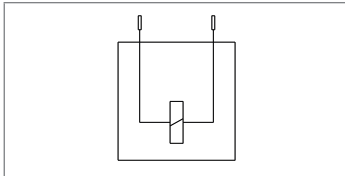

#### ▼ Mating connector DEUTSCH DT06-2S-EP04

Consisting of	DT designation
1 housing	DT06-2S-EP04
1 wedge	W2S
2 sockets	0462-201-16141

The mating connector is not included in the scope of delivery. This can be supplied by Bosch Rexroth on request (material number R902601804).

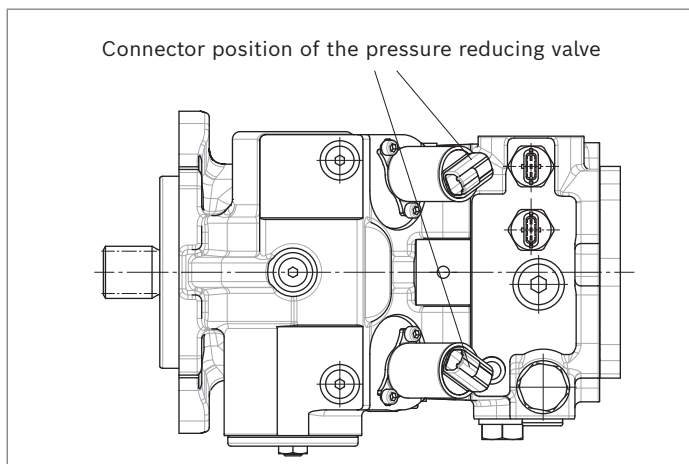

## Pressure sensor

The pressure on the working ports **A** and **B** can be recorded using the mounted PR4 pressure sensors in **M<sub>A</sub>** and **M<sub>B</sub>**. Type code, technical data, dimensions and safety instructions about the sensor can be found in the relevant data sheet 95156.

#### ▼ Permissible variants

Pressure sensor PR4	
Measuring range	0 ... 600 bar
Mechanical connection	M14 × 1.5 according to ISO 6149-2
Electrical connection	Bosch Compact
Output signal	SENT according to SAE J2716 JAN 2010
	Option: 0.5 ... 4.5 V ratiometric (at 5±0 V supply voltage)

#### Notes

- ▶ Only the variants of the pressure sensor PR4 listed in the table are approved for the A4VG series 35.
- ▶ On delivery, the position of the pressure sensor connector position differs from that shown in the drawing.

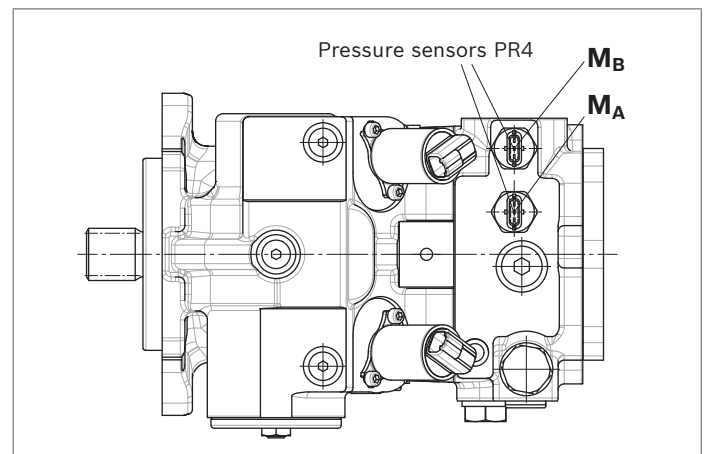

## Installation dimensions for coupling assembly

To ensure that rotating components (coupling hub) and fixed components (housing, retaining ring) do not come into contact with each other, the installation conditions described here must be observed. This depends on the pump size and the splined shaft.

### SAE splined shaft (spline according to ANSI B92.1a)

#### Splined shaft **S7, V8** or **T1**

The outer diameter of the coupling hub must be smaller than the inner diameter of the retaining ring (dimension  $d_2$ ) in the area near the drive shaft collar (dimension  $x_2 - x_3$ ).

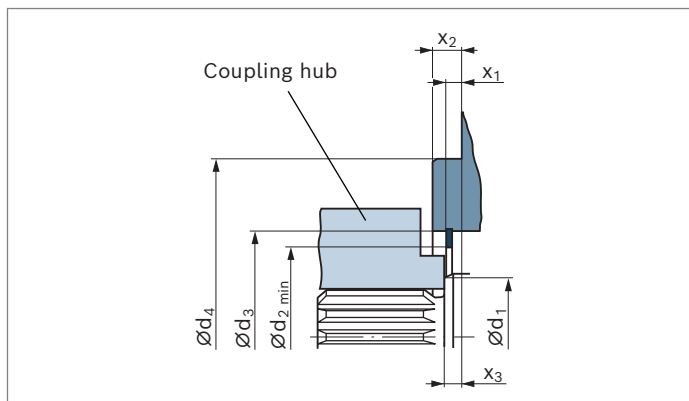

### DIN splined shaft (spline according to DIN 5480)

#### Splined shaft **Z8**

The outer diameter of the coupling hub must be smaller than the case diameter  $d_3$  in the area near the drive shaft collar (dimension  $x_2 - x_4$ ).

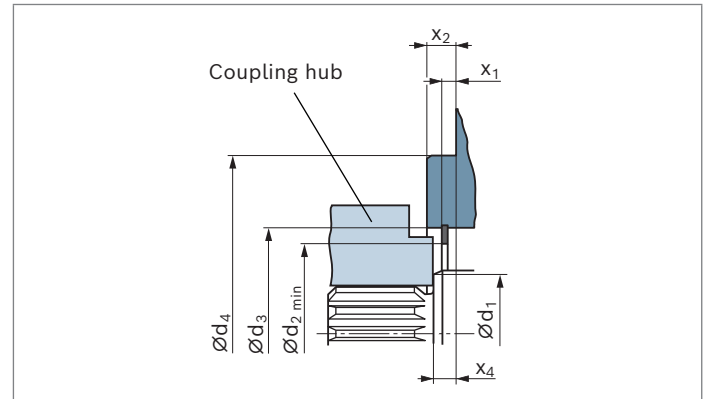

NG	$\varnothing d_1$ SAE splined shaft	$\varnothing d_1$ DIN splined shaft	$\varnothing d_{2, \min}$	$\varnothing d_3$	$\varnothing d_4$	$x_1$	$x_2$	$x_3$	$x_4$
56	38.5	37.1	54.4	$68 \pm 0.1$	$127 \begin{smallmatrix} 0 \\ -0.063 \end{smallmatrix}$	$7.0 + 0.2$	$12.7 - 0.5$	$8 \begin{smallmatrix} +0.9 \\ -0.6 \end{smallmatrix}$	$10 \begin{smallmatrix} +0.9 \\ -0.6 \end{smallmatrix}$
71	43.5	42.1	66.5	$81 \pm 0.1$	$127 \begin{smallmatrix} 0 \\ -0.063 \end{smallmatrix}$	$7.0 + 0.2$	$12.7 - 0.5$	$8 \begin{smallmatrix} +0.9 \\ -0.6 \end{smallmatrix}$	$10 \begin{smallmatrix} +0.9 \\ -0.6 \end{smallmatrix}$
90	48.5	47.1	66.5	$81 \pm 0.1$	$127 \begin{smallmatrix} 0 \\ -0.063 \end{smallmatrix}$	$6.8 + 0.2$	$12.7 - 0.5$	$8 \begin{smallmatrix} +0.9 \\ -0.6 \end{smallmatrix}$	$10 \begin{smallmatrix} +0.9 \\ -0.6 \end{smallmatrix}$

## Installation instructions

### General

The axial piston unit must be filled with hydraulic fluid and air bled during commissioning and operation. This must also be observed following a longer standstill as the axial piston unit may empty via the hydraulic lines.

The leakage in the housing area must be directed to the reservoir via the highest drain port (**T<sub>1</sub>**, **T<sub>2</sub>**).

For combination pumps, the leakage must be drained off at each single pump.

If a shared drain line is used for several units, make sure that the respective case pressure in each unit is not exceeded. The shared drain line must be dimensioned to ensure that the maximum permissible case pressure of all connected units is not exceeded in any operating condition, particularly at cold start. If this is not possible, separate drain lines must be laid, if necessary.

To prevent the transmission of structure-borne noise, use elastic elements to decouple all connecting lines from all vibration-capable components (e.g. reservoir, frame parts).

Under all operating conditions, the suction line and drain line must flow into the reservoir below the minimum fluid level. The permissible suction height  $h_{S \max}$  results from the total pressure loss; it must not, however, be higher than  $h_{S \max} = 800 \text{ mm}$ .

The suction pressure at port **S** must also not fall below the minimum value of 0.8 bar absolute during operation (cold start 0.5 bar absolute).

When designing the reservoir, ensure that there is adequate distance between the suction line and the drain line. We recommend using a baffle (baffle plate) between suction line and drain line. A baffle improves the air separation ability as it gives the hydraulic fluid more time for desorption. Apart from that, this prevents the heated return flow from being drawn directly back into the suction line. The suction port must be supplied with air-free, calmed and cooled hydraulic fluid.

### Installation position

See the following examples 1 to 10.

Further installation positions are available upon request.  
Recommended installation position: 1 and 2.

#### Notice

- ▶ For optimum function and dynamics of the axial piston unit, a complete filling of the two stroking chambers **X<sub>1</sub>** and **X<sub>2</sub>** with hydraulic fluid is required. By swiveling the swashplate several times during commissioning, this can usually be ensured. In case of unfavorable installation positions, air bleeding of the stroking chambers may take some time, so we recommend filling the stroking chambers via ports **X<sub>1</sub>** and **X<sub>2</sub>** before installation.
- ▶ In certain installation positions, an influence on the adjustment or control can be expected. Gravity, dead weight and case pressure can cause minor characteristic shifts and changes in response time.

#### Key

<b>R</b>	Air bleed port
<b>S</b>	Suction port
<b>T<sub>1</sub>, T<sub>2</sub></b>	Drain port
<b>X<sub>1</sub>, X<sub>2</sub></b>	Control pressure port
<b>G</b>	Boost pressure port inlet
<b>SB</b>	Baffle (baffle plate)
$h_{t \min}$	Minimum required immersion depth (200 mm)
$h_{\min}$	Minimum required distance to reservoir bottom (100 mm)
$h_{S \max}$	Maximum permissible suction height (800 mm)

**Below-reservoir installation (standard)**

Below-reservoir installation means that the axial piston unit is installed outside of the reservoir below the minimum fluid level.

▼ **Installation position 1**

Air bleed the housing	Air bleed the stroking chamber	Filling
T <sub>1</sub> , R	X <sub>1</sub> , X <sub>2</sub>	G <sup>1)</sup> , S, T <sub>1</sub> , X <sub>1</sub> , X <sub>2</sub>

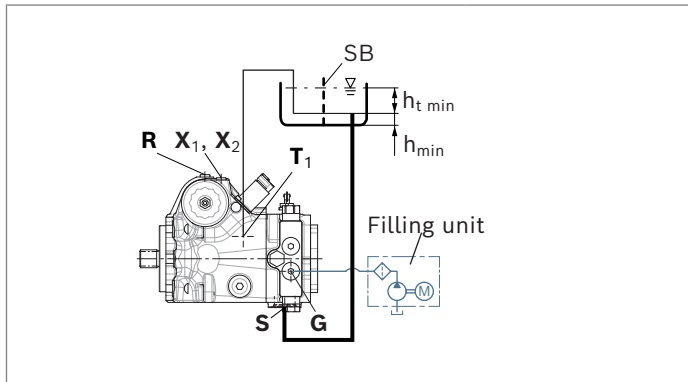

▼ **Installation position 4**

Air bleed the housing	Air bleed the stroking chamber	Filling
T <sub>1</sub>	X <sub>1</sub>	G <sup>1)</sup> , S, T <sub>1</sub> , X <sub>1</sub>

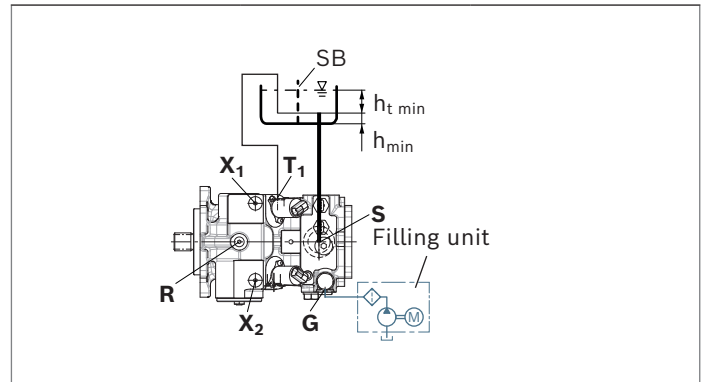

▼ **Installation position 2**

Air bleed the housing	Air bleed the stroking chamber	Filling
T <sub>2</sub>	-	G <sup>1)</sup> , S, T <sub>2</sub>

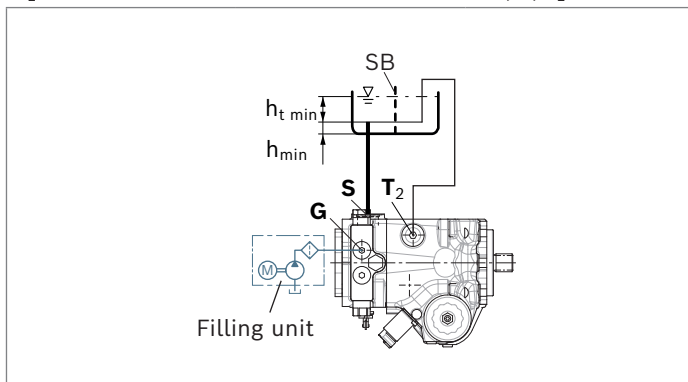

▼ **Installation position 5**

Air bleed the housing	Air bleed the stroking chamber	Filling
T <sub>2</sub>	X <sub>2</sub>	G <sup>1)</sup> , S, T <sub>2</sub> , X <sub>1</sub> , X <sub>2</sub>

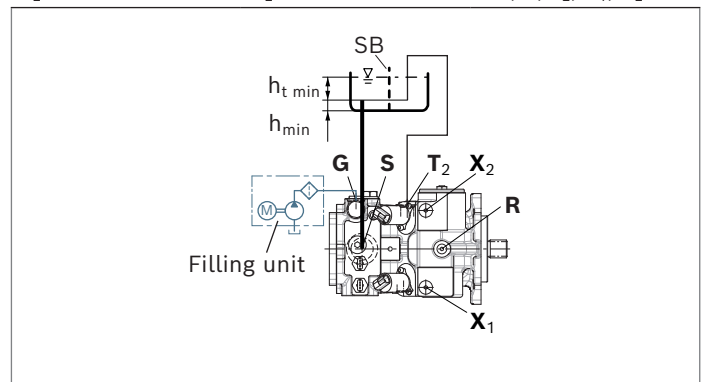

▼ **Installation position 3**

Air bleed the housing	Air bleed the stroking chamber	Filling
T <sub>2</sub>	X <sub>1</sub> , X <sub>2</sub>	G <sup>1)</sup> , S, T <sub>2</sub> , X <sub>1</sub> , X <sub>2</sub>

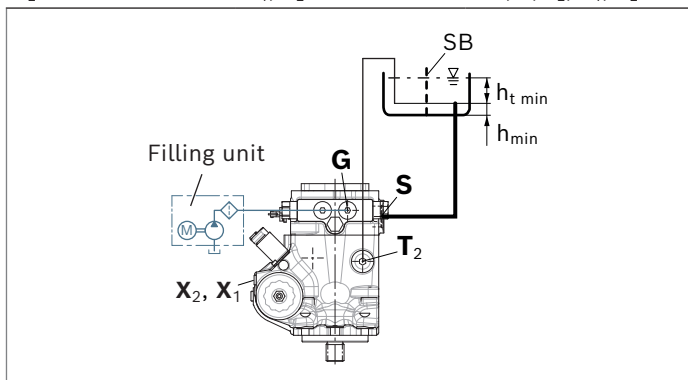

1) Recommendation: Filling with filling unit.  
When filling without filling unit, the pump must be filled at the highest drain port.

**Above-reservoir installation**

Above-reservoir installation means that the axial piston unit is installed above the minimum fluid level of the reservoir.

Observe the maximum permissible suction height  
 $h_{S \max} = 800 \text{ mm}$ .

▼ **Installation position 6**

Air bleed the housing	Air bleed the stroking chamber	Filling
R	X <sub>1</sub> , X <sub>2</sub>	G <sup>1)</sup> , S, T <sub>1</sub> , X <sub>1</sub> , X <sub>2</sub>

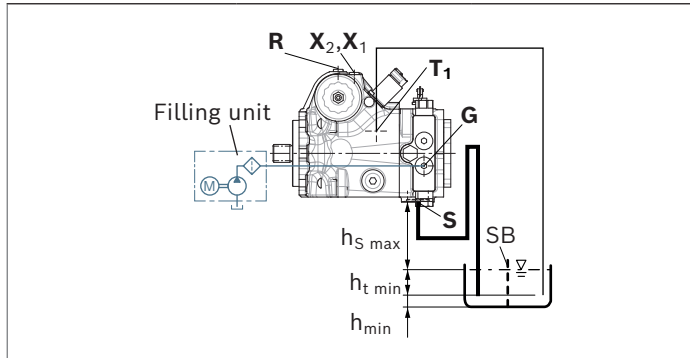

▼ **Installation position 9**

Air bleed the housing	Air bleed the stroking chamber	Filling
S, T <sub>1</sub>	X <sub>1</sub>	G <sup>1)</sup> , S, T <sub>1</sub> , X <sub>1</sub>

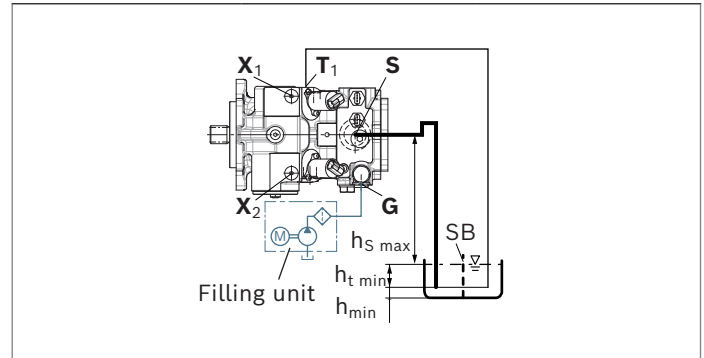

▼ **Installation position 7**

Air bleed the housing	Air bleed the stroking chamber	Filling
- T <sub>2</sub>	-	G <sup>1)</sup> , S, T <sub>2</sub>

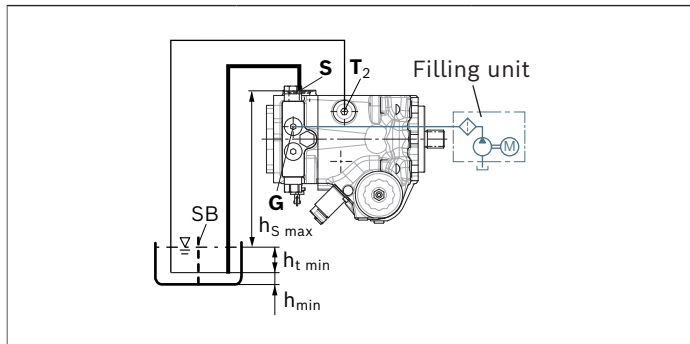

▼ **Installation position 10**

Air bleed the housing	Air bleed the stroking chamber	Filling
S, T <sub>2</sub>	X <sub>2</sub>	G <sup>1)</sup> , S, T <sub>2</sub> , X <sub>1</sub> , X <sub>2</sub>

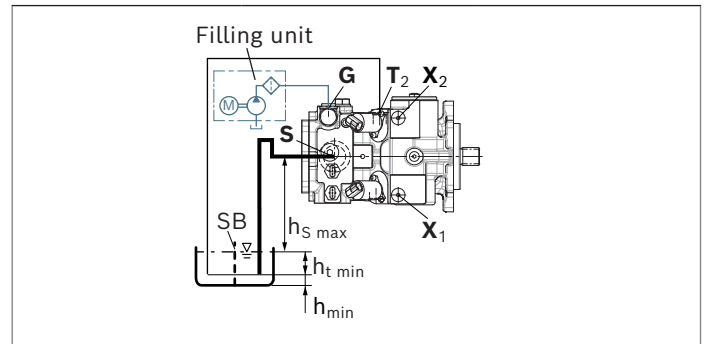

▼ **Installation position 8**

Air bleed the housing	Air bleed the stroking chamber	Filling
S, T <sub>2</sub>	X <sub>1</sub> , X <sub>2</sub>	G <sup>1)</sup> , S, T <sub>2</sub> , X <sub>1</sub> , X <sub>2</sub>

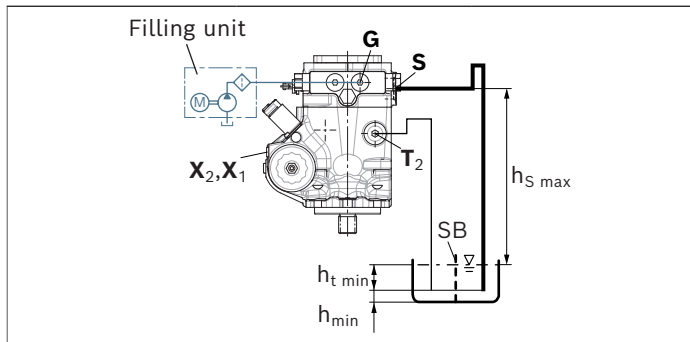

1) Recommendation: Filling with filling unit.  
When filling without filling unit, the pump must be filled at the highest drain port.

## Project planning notes

- ▶ The pump is intended for use in a closed circuit.
- ▶ The project planning, installation and commissioning of the axial piston unit requires the involvement of skilled personnel.
- ▶ Before using the axial piston unit, please read the corresponding instruction manual completely and thoroughly. If necessary, this can be requested from Bosch Rexroth.
- ▶ Before finalizing your design, please request a binding installation drawing.
- ▶ The specified data and notes contained herein must be observed.
- ▶ Depending on the operating conditions of the axial piston unit (working pressure, fluid temperature), the characteristic curve may shift.
- ▶ Preservation: Our axial piston units are supplied as standard with preservation protection for a maximum of 12 months. If longer preservation protection is required (maximum 24 months), please specify this in plain text when placing your order. The preservation periods apply under optimal storage conditions, details of which can be found in the data sheet 90312 or the instruction manual.
- ▶ Not all configuration variants of the product are approved for use in safety functions according to ISO 13849. Please consult the responsible contact person at Bosch Rexroth if you require reliability parameters (e.g.  $MTTF_D$ ) for functional safety.
- ▶ Depending on the type of control used, electromagnetic effects can be produced when using solenoids. Applying a direct voltage signal (DC) to solenoids does not create electromagnetic interference (EMI) nor is the solenoid affected by EMI. Electromagnetic interference (EMI) potential exists when operating and controlling a solenoid with a modulated direct voltage signal (e.g. PWM signal). Appropriate testing and measures should be taken by the machine manufacturer to ensure other components or operators (e.g. with pacemaker) are not affected by this potential.
- ▶ Pressure cut-off (hydraulic or electronic) is not a sufficient safeguard against pressure overload. Therefore, a pressure relief valve must be added to the hydraulic system (integrated in the pump or external in the system). Observe the technical limits of the pressure relief valves here.
- ▶ With dynamic power flow (switch of pumps to operation as a motor) a maximum of 95%  $V_{g \max}$  is permissible. We recommend configuring the software accordingly.
- ▶ Please note that a hydraulic system is an oscillating system. This can lead, for example, to the stimulation the natural frequency within the hydraulic system during operation at constant rotational speed over a long period of time. The excitation frequency of the pump is 9 times the rotational speed frequency. This can be prevented, for example, with suitably designed hydraulic lines.
- ▶ Please note the details regarding the tightening torques of port threads and other threaded joints in the instruction manual.
- ▶ The ports and fastening threads are designed for the  $p_{\max}$  permissible pressures of the respective ports, see the connection tables. The machine or system manufacturer must ensure that the connecting elements and lines correspond to the specified application conditions (pressure, flow, hydraulic fluid, temperature) with the necessary safety factors.
- ▶ The service ports and function ports are only designed to accommodate hydraulic lines.

## Safety instructions

- ▶ During and shortly after operation, there is a risk of burns on the axial piston unit and especially on the solenoids. Take the appropriate safety measures (e.g. by wearing protective clothing).
- ▶ Moving parts in control equipment (e.g. valve spools) can, under certain circumstances, get stuck in position as a result of contamination (e.g. contaminated hydraulic fluid, abrasion, or residual dirt from components). As a result, the hydraulic fluid flow and the build-up of torque in the axial piston unit can no longer respond correctly to the operator's specifications. Even the use of various filter elements (external or internal flow filtration) will not rule out a fault but merely reduce the risk. The machine/system manufacturer must test whether remedial measures are needed on the machine for the application concerned in order to bring the driven consumer into a safe position (e.g. safe stop) and ensure any measures are properly implemented.

**Bosch Rexroth AG**  
Glockeraustraße 2  
89275 Elchingen  
Germany  
Phone +49 7308 82-0  
info.ma@boschrexroth.de  
www.boschrexroth.com

© Bosch Rexroth AG 2020. All rights reserved, also regarding any disposal, exploitation, reproduction, editing, distribution, as well as in the event of applications for industrial property rights. The data specified within only serves to describe the product. No statements concerning a certain condition or suitability for a certain application can be derived from our information. The information given does not release the user from the obligation of own judgment and verification. It must be remembered that our products are subject to a natural process of wear and aging.