

Axial piston variable pump A4CSG series 30 and 33

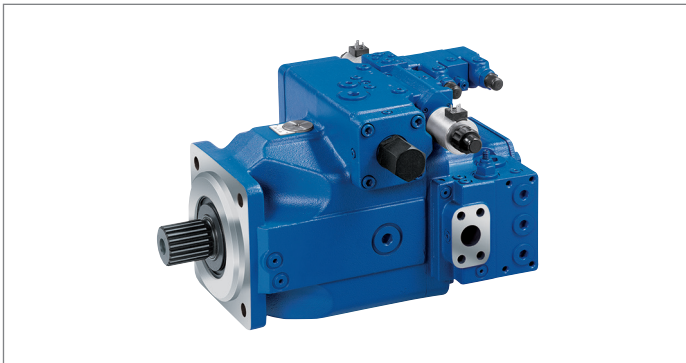

- ▶ Robust high-pressure pump with integrated boost pump
- ▶ Sizes 250 to 750
- ▶ Nominal pressure 350 bar
- ▶ Maximum pressure 400 bar
- ▶ Closed circuit

Features

- ▶ Variable pump in axial piston swashplate design for hydrostatic drives in closed circuits.
- ▶ Flow is proportional to drive speed and displacement.
- ▶ The flow can be infinitely varied by adjusting the swashplate angle.
- ▶ The boost pump required for the operation in the closed circuit and the associated valve technology are integrated in the pump
- ▶ The integrated boost pump is used as a feed pump and pilot pressure supply
- ▶ Compact design with extremely short overall length
- ▶ Good power to weight ratio
- ▶ Low noise level
- ▶ Long service life
- ▶ High efficiency
- ▶ Electro-hydraulic proportional adjustment with neutral position in case of power failure
- ▶ Through-drive and pump combination are also possible with an integrated boost pump
- ▶ For descriptions of the control devices, see separate data sheets 92076, 92080 and 92084

Contents

Type code	2
Hydraulic fluids	4
Shaft seal	5
Working pressure range	6
Technical data	8
Overview of control devices	10
Dimensions, sizes 250 to 750	13
Overview of mounting options on A4CSG	27
Combination pumps	28
Integrated boost pump and integrated valve technology (version F..)	29
External boost pressure supply	31
Filtration types	32
Installation instructions	34
Project planning notes	37
Safety instructions	38
Related documentation	38

Type code

01	02	03	04	05	06	07	08	09	10	11	12	13	14
A4CS	G		/			-	V		35			4	

Axial piston unit

01	Swashplate design, variable, nominal pressure 350 bar, maximum pressure 400 bar	A4CS
----	---	-------------

Operating mode

02	Pump, closed circuit	G
----	----------------------	----------

Size

03	Geometric displacement, see "Technical data" on page 8	250	355	500	750
----	--	------------	------------	------------	------------

Control device

04	Electro-hydraulic pump control system with hitch control valve		●	●	●	●	HS5..
	Analog electro-hydraulic control with proportional valve	see 92076	○	●	●	●	EO2
	Customer compact solution (prepared for customer-specific control system) electro-hydraulic control with proportional valve and with AWAX		●	○	●	○	HM2C
	Hydraulic control pilot-pressure related	see 92080	●	●	●	●	HD...
	Electro-hydraulic control with proportional solenoid	see 92084	●	●	●	●	EP

Series

		250	355	500	750
--	--	------------	------------	------------	------------

05	Standard version	▲	●	▲	●	30
	Efficiency-optimized version	●	-	●	-	33

Directions of rotation

		250	355	500	750
--	--	------------	------------	------------	------------

06	Viewed on drive shaft	clockwise	●	●	●	●	R
		counter-clockwise	●	●	●	●	L

Sealing material

		250	355	500	750
--	--	------------	------------	------------	------------

07	FKM (fluorocarbon rubber)	●	●	●	●	V
----	---------------------------	---	---	---	---	----------

Drive shaft

		250	355	500	750
--	--	------------	------------	------------	------------

08	Parallel keyed shaft DIN 6885	●	●	●	●	P
	Splined shaft DIN 5480	●	●	●	●	Z

Mounting flange

		250	355	500	750
--	--	------------	------------	------------	------------

09	In accordance with ISO 3019-2 (metric)	4-hole	●	●	-	-	B
		8-hole	-	-	●	●	H

Working port

		250	355	500	750
--	--	------------	------------	------------	------------

10	SAE flange ports A and B , positioned laterally opposite each other, metric fastening thread	●	●	●	●	35
	SAE flange port S , positioned laterally offset from A and B by 90°, metric fastening thread					

Boost pump

		250	355	500	750
--	--	------------	------------	------------	------------

11	With integrated boost pump	●	●	●	●	F
	Without integrated boost pump	●	●	●	●	K

● = Available ○ = On request - = Not available ▲ = Not for new projects

Notice

- ▶ Note the project planning notes on page 37.
- ▶ In addition to the type code, please specify the relevant technical data when placing your order.
- ▶ For information on the mounting situation of combination pumps, see page 27.

01	02	03	04	05	06	07	08	09	10	11	12	13	14
A4CS	G			/			-	V		35		4	

Through-drive (for mounting options, see page 27)

		250	355	500	750	
12	With through-drive shaft, without hub, without intermediate flange, closed with cover	●	●	●	●	99
	With through drive for mounting a second unit					
	Flange ISO 3019-2 (metric) Hub for splined shaft DIN 5480					
	125, 4-hole W32×2×14×9g	○	●	●	○	31
	140, 4-hole W40×2×18×9g	○	○	●	○	33
	160, 4-hole W50×2×24×9g	●	●	●	●	34
	224, 4-hole W60×2×28×9g	●	○	●	○	35
	224, 4-hole W70×3×22×9g	-	●	●	○	77
	315, 8-hole W80×3×25×9g	-	-	●	○	43
	400, 8-hole W90×3×28×9g	-	-	-	○	76
	Flange ISO 3019-2 (metric) Hub for splined shaft SAE J744					
	80, 2-hole 3/4 in (19-4)	○	○	○	○	B2
	100, 2-hole 7/8 in (22-4)	●	●	○	○	B3
	100, 2-hole 1 in (25-4)	○	○	○	○	B4
	125, 4-hole 1 in (25-4)	○	○	○	○	E1
	125, 2-hole 1 1/4 in (32-4)	●	●	○	○	B5
	160, 4-hole 1 1/4 in (32-4)	○	○	○	○	B8
	125, 2-hole 1 1/2 in (38-4)	○	●	○	○	B6
	180, 4-hole 1 1/2 in (38-4)	○	○	○	○	B9
	180, 4-hole 1 3/4 in (44-4)	○	○	○	○	B7
Flange SAE J744 Hub for splined shaft SAE J744						
82-2 (A) 5/8 in (16-4)	●	●	●	●	01	
82-2 (A) 3/4 in (19-4)	○	●	●	○	52	
101-2 (B) 7/8 in (22-4)	●	●	●	○	68	
101-2 (B) 1 in (25-4)	○	●	●	○	04	
127-2 (C) 1 1/4 in (32-4)	●	●	●	○	07	
127-4 (C) 1 1/4 in (32-4)	○	○	○	○	15	
127-2 (C) 1 1/2 in (38-4)	●	●	●	○	24	
152-4 (D) 1 3/4 in (44-4)	●	●	●	●	17	

Valves

		250	355	500	750	
13	Boost, control pressure relief and flushing valve integrated; pilot operated high-pressure relief valve integrated	●	●	●	●	4

Filtration (see page 32)

		250	355	500	750	
14	Without filter	●	●	●	●	N
	With threaded port for filter in the boost circuit	●	●	●	●	D
	With mounted filter (optical-electric contamination indicator) in the boost circuit	●	●	●	●	M
	With threaded port for filter in the boost circuit (D) and intermediate plate filter for HS control (see data sheet 92076)	○	●	-	-	Z
	With mounted filter in the boost circuit (M) and intermediate plate filter for HS control (see data sheet 92076)	○	○	-	-	U

● = Available ○ = On request - = Not available

Hydraulic fluids

The A4CSG variable pump is designed for operation with HLP mineral oil according to DIN 51524.

Application instructions and requirements for hydraulic fluid selection, behavior during operation as well as disposal and environmental protection should be taken from the following data sheets before the start of project planning:

- ▶ 90220: Hydraulic fluids based on mineral oils and related hydrocarbons
- ▶ 90221: Environmentally acceptable hydraulic fluids
- ▶ 90222: Fire-resistant, water-free hydraulic fluids (HFDR/HFDU)

Selection of hydraulic fluid

Bosch Rexroth evaluates hydraulic fluids on the basis of the Fluid Rating according to the technical data sheet 90235.

Hydraulic fluids with positive evaluation in the Fluid Rating are listed in the following data sheet:

- ▶ 90245: Bosch Rexroth Fluid Rating List for Rexroth hydraulic components (pumps and motors)

The hydraulic fluid should be selected so that the operating viscosity in the operating temperature range is within the optimum range (v_{opt} ; see selection diagram).

Viscosity and temperature of hydraulic fluids

	Viscosity	Shaft seal	Temperature ²⁾	Comment
Cold start	$v_{max} \leq 1600 \text{ mm}^2/\text{s}$	FKM	$\vartheta_{St} \geq -25^\circ\text{C}$	$t \leq 3 \text{ min}$, without load ($p \leq 50 \text{ bar}$), $n \leq 1000 \text{ rpm}$ Permissible temperature difference between axial piston unit and hydraulic fluid in the system maximum 25 K
Warm-up phase	$v = 1600 \dots 400 \text{ mm}^2/\text{s}$			$t \leq 15 \text{ min}$, $p \leq 0.7 \times p_{nom}$ und $n \leq 0.5 \times n_{nom}$
Permissible operating range	$v = 400 \dots 10 \text{ mm}^2/\text{s}^{1)}$	FKM	$\vartheta \leq +110^\circ\text{C}$	Measured at port T
	$v_{opt} = 36 \dots 16 \text{ mm}^2/\text{s}$			Optimal operating viscosity and efficiency range
Short-term operation	$v_{min} = 10 \dots 7 \text{ mm}^2/\text{s}$	FKM	$\vartheta \leq +110^\circ\text{C}$	$t \leq 3 \text{ min}$, $p \leq 0.3 \times p_{nom}$, measured at port T

▼ Selection diagram

Maximum permissible viscosity on cold start

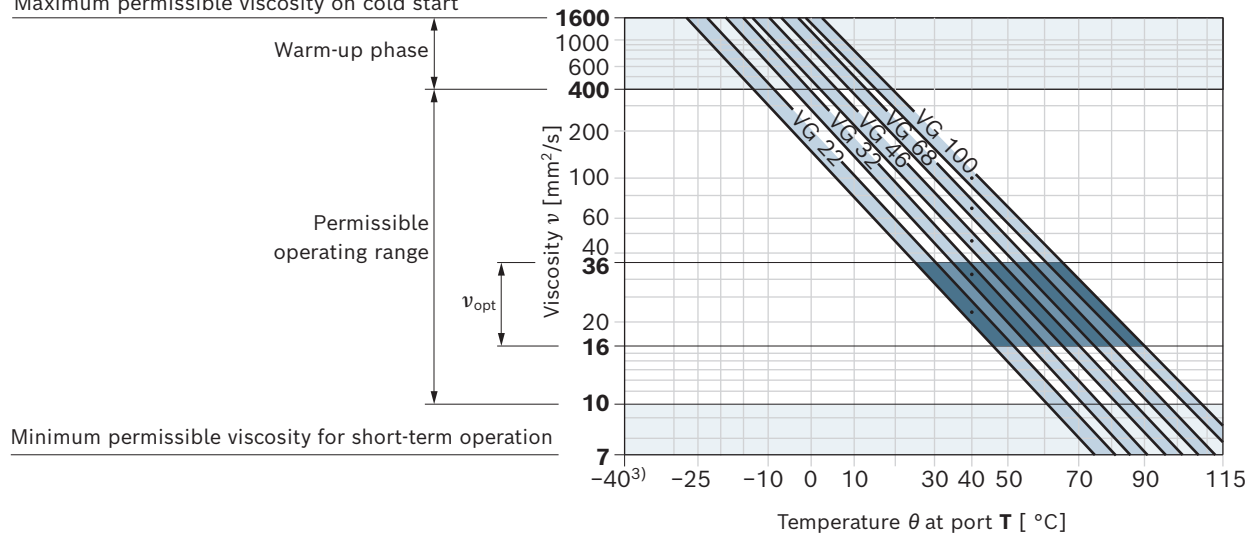

Notice

The maximum circuit temperature of +115°C must not be exceeded at the working ports **A** and **B** complying with the permissible viscosity.

1) This corresponds, for example on the VG 46, to a temperature range of +4°C to +85°C (see selection diagram)

2) If the temperature at extreme operating parameters cannot be adhered to, please contact us.

3) For applications in the low-temperature range, please contact us.

Filtration of the hydraulic fluid

Finer filtration improves the cleanliness level of the hydraulic fluid, which increases the service life of the axial piston unit.

A cleanliness level of at least 20/18/15 under ISO 4406 should be maintained.

At a hydraulic fluid viscosity of less than 10 mm²/s (e.g. due to high temperatures during short-term operation), a cleanliness level of at least 19/17/14 according to ISO 4406 is required.

Examples of temperatures of hydraulic fluids at a viscosity of 10 mm²/s:

- ▶ 73 °C at HLP 32
- ▶ 85 °C at HLP 46

Optionally, a "threaded port for filters in the boost circuits" with the order designation **D** or "with mounted filter in the boost circuits" with the order designation **M** is available. Description see page 32 to 33.

Bearing flushing

Bearing flushing is required for a safe, continuous operation under the following operating conditions:

- ▶ Operation with borderline conditions for temperature and viscosity.
- ▶ When installed vertically (drive shaft up) for lubricating the front bearing and shaft seal.

Port "**U**" at the front flange of the variable displacement pump is used for bearing flushing. The flushing fluid flows through the front bearing and discharges with the pump drain at the drain port.

The following flushing flows are recommended depending on size:

Size	250	355	500	750
Recommended flushing flow q_{sp} l/min	10	15	20	30

For the flushing flows stated, there is a pressure differential of approximately 3 bar between the port "**U**" (including fitting) and the housing area.

Notice

When using external bearing flushing, the throttle screw in port **U** must be turned to the stop.

Shaft seal

Permissible pressure load

The service life of the shaft seal ring is affected by the rotational speed of the axial piston unit and the leakage pressure (case pressure). Momentary ($t < 0.1$ s) pressure peaks of up to 6 bar absolute are acceptable. The service life of the shaft seal decreases with increasing frequency of pressure peaks and increasing mean differential pressure.

The pressure in the housing must be equal to or greater than the ambient pressure.

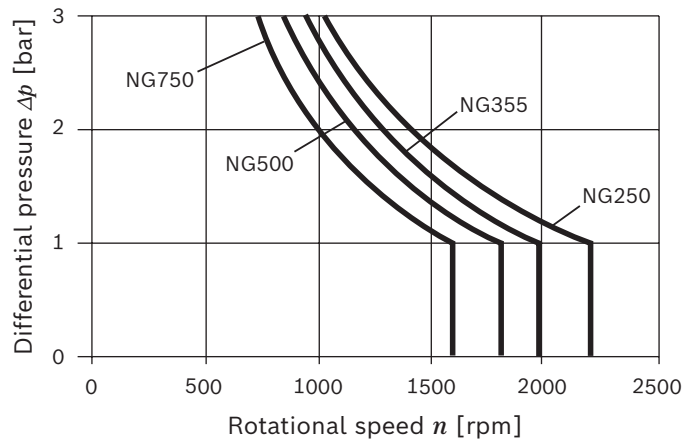

Working pressure range

Pressure at working port A or B		Definition	
Nominal pressure p_{nom}	350 bar	The nominal pressure corresponds to the maximum design pressure.	
Maximum pressure p_{max}	400 bar	The maximum pressure corresponds to the maximum working pressure within a single operating period. The sum of single operating periods must not exceed the total operating period.	
	Single operating period		1 s
	Total operating period		300 h
Minimum pressure (high-pressure side)	15 bar	Minimum pressure at the high-pressure side (A or B) which is required to prevent damage to the axial piston unit.	
Minimum pressure (low-pressure side)	speed related (see diagram on page)	Minimum pressure on the low-pressure side (A or B) required to prevent damage to the axial piston unit. The low pressure is applied at port M_{K4} when the flushing slide is deflected.	
Rate of pressure change $R_{A\ max}$	16000 bar/s	Maximum permissible speed of pressure build-up and reduction during a pressure change across the entire pressure range.	
Boost pressure ¹⁾			
Minimum boost pressure p_{Sp} (at n_{nom})	20 bar	NG750 series 30	
	16 bar	NG250 to 500 series 30	
	10 bar ²⁾	NG250 to 500 series 33	
Maximum boost pressure $p_{Sp\ max}$ at HS5(E)L, HD/EP	25 bar	Measuring port: M_{K4} (Please contact us for multiple coupled pumps.)	
Maximum static boost pressure $p_{Sp\ max}$	30 bar		
Permissible pressure peaks in boost pressure	minimum		4 bar
	maximum		40 bar
Pressure at suction port S (version with integrated boost pump)			
Minimum pressure $p_{S\ min}$	≥0.8 bar absolute	Minimum pressure at suction port S (inlet) that is required in order to avoid damage to the axial piston unit.	
Maximum pressure $p_{S\ max}$	30 bar absolute		
Case pressure at port K ₂ , K ₃ , R(L)			
Max. static pressure $p_{L\ max}$	4 bar absolute	Maximum 1.2 bar higher than inlet pressure at port S , but not higher than $p_{L\ max}$. The permissible case pressure depends on the rotational speed (see diagram on page 5). A drain line to the reservoir is required.	
Pressure peak $p_{L\ peak}$	6 bar absolute	$t < 0.1\ s$	
Control pressure for EP and HD control			
Minimum required control pressure $p_{St\ min}$	double boost pressure at NG 355 +5 bar	Measuring port M₁ (small stroking chamber)	

Notice

Working pressure range applies when using hydraulic fluids based on mineral oils. Please contact us for values for other hydraulic fluids.

- 1) Low pressure monitoring is recommended for special applications (for further information see "Boost pressure" on page 29)
- 2) A boost pressure of 10 bar is possible, but it must be ensured that the minimum pressure on the high-pressure side of 15 bar is maintained.

Required low pressure depending on speed ratio

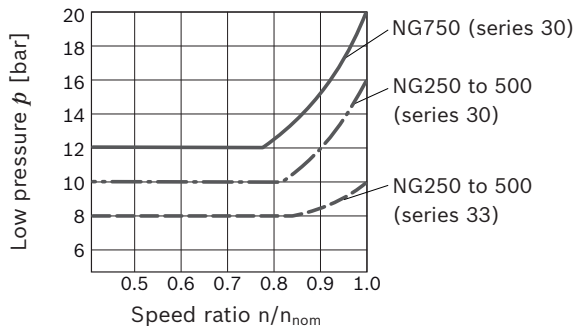

▼ **Rate of pressure change**

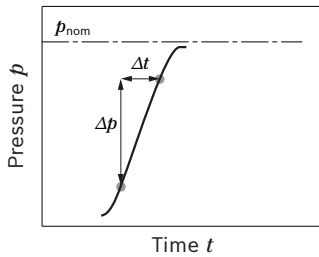

▼ **Pressure definition**

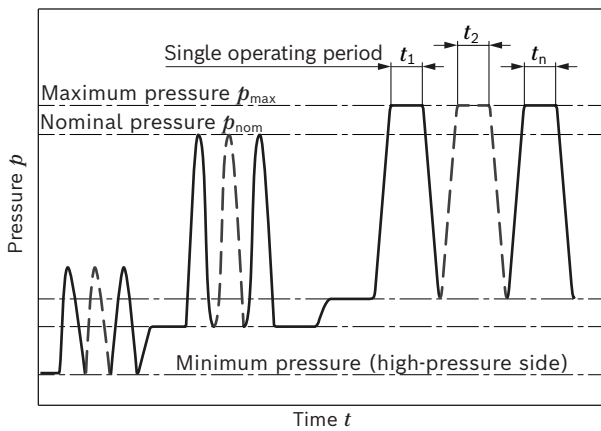

Total operating period = $t_1 + t_2 + \dots + t_n$

Notice

Working pressure range applies when using hydraulic fluids based on mineral oils. Please contact us for values for other hydraulic fluids.

Technical data

Size		NG		250	355	500	750
Geometric displacement, per revolution	variable pump	$V_{g \max}$	cm ³	250	355	500	750
	integrated boost pump	$V_{g \text{ Sp}}$	cm ³	63	80	98	143
Rotational speed ¹⁾	maximum at $V_{g \max}$	n_{nom}	rpm	2200	2000	1800	1600
	minimum ²⁾	n_{min}	rpm	800	800	800	800
Flow	at $V_{g \max}$ and n_{\max}	q_v	l/min	550	710	900	1200
	at $n_E = 1500 \text{ min}^{-1}$ and $V_{g \max}$	q_{VE}	l/min	375	533	750	1125
Power ³⁾	at $V_{g \max}$, n_{\max} and $\Delta p = 350 \text{ bar}$	P	kW	321	414	525	700
	at $n_E = 1500 \text{ min}^{-1}$, $V_{g \max}$ and $\Delta p = 350 \text{ bar}$	P_E	kW	219	311	438	656
Torque ³⁾	at $V_{g \max}$ and $\Delta p = 350 \text{ bar}$	M	Nm	1391	1976	2783	4174
	at $V_{g \max}$ and $\Delta p = 100 \text{ bar}$	M	Nm	398	564	795	1193
Rotary stiffness of drive shaft	P	c	kNm/rad	527	800	1145	1860
	Z	c	kNm/rad	543	770	1209	1812
Moment of inertia of the rotary group		J_{TW}	kgm ²	0.0959	0.19	0.3325	0.66
Maximum angular acceleration ⁴⁾		α	rad/s ²	775	600	540	400
Case volume		V	l	10	8	14	19
Weight (pump with EP control and integrated boost pump without filter) approx.		m	kg	260	275	390	520

Determination of the operating characteristics		
Flow	$q_v = \frac{V_g \cdot n \cdot \eta_v}{1000}$	[l/min]
Torque	$M = \frac{V_g \cdot \Delta p}{20 \cdot \pi \cdot \eta_{hm}}$	[Nm]
Power	$P = \frac{2 \pi \cdot M \cdot n}{60000} = \frac{q_v \cdot \Delta p}{600 \cdot \eta_t}$	[kW]
Key		
V_g	=	Displacement per revolution [cm ³]
Δp	=	Differential pressure [bar]
n	=	Rotational speed [rpm]
η_v	=	Volumetric efficiency
η_{hm}	=	Hydraulic-mechanical efficiency
η_t	=	Total efficiency ($\eta_t = \eta_v \cdot \eta_{hm}$)

Notice

- Theoretical values, without efficiency and tolerances; values rounded
- Operation above the maximum values or below the minimum values may result in a loss of function, a reduced service life or in the destruction of the axial piston unit. Bosch Rexroth recommends checking loads through tests or calculation/simulation and comparing them with the permissible values.

Flow direction

Direction of rotation		Swiveling range*
Clockwise	Counter-clockwise	
B to A	A to B	Clockwise
A to B	B to A	Counter-clockwise

* cf. swivel angle indicator

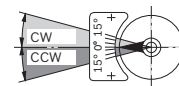

- The values are applicable:
 - for the optimum viscosity range from $\nu_{\text{opt}} = 36$ to $16 \text{ mm}^2/\text{s}$
 - with hydraulic fluid based on mineral oils
- Lower values on request
- Without boost pump
- The data are valid for values between the minimum required and maximum permissible rotational speed.
Valid for external excitation (e.g. diesel engine 2 to 8 times the rotary frequency; cardan shaft 2 times the rotary frequency).
The limit value is only valid for a single pump.
The load capacity of the connection parts must be considered.

Permissible radial and axial loading of the drive shaft

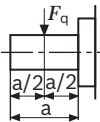
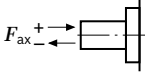
Size	NG	250	355	500	750	
Drive shaft						
Maximum radial force at X/2		$F_{q \max}$ N	2000	2200	2500	3000
Maximum axial force		$+ F_{ax \max}$ N $- F_{ax \max}$ N	1800	2000	2000	2000

Notice

- ▶ The values given are maximum values and do not apply to continuous operation.
- All loads of the drive shaft reduce the bearing service life!

Permissible inlet and through-drive torques

Size	NG	250	355	500	750		
Torque at $V_{g \max}$ and $\Delta p = 350 \text{ bar}^1$	M_{\max}	Nm	1391	1976	2783	4174	
Maximum input torque on drive shaft ²⁾							
	Splined shaft Z	$M_{E \max}$	Nm	2782	3952	5566	8348
	Shaft key P	$M_{E \max}$	Nm	2300	3557	5200	7513
Maximum through-drive torque	$M_{D \max}$	Nm	1391	1976	2783	4174	

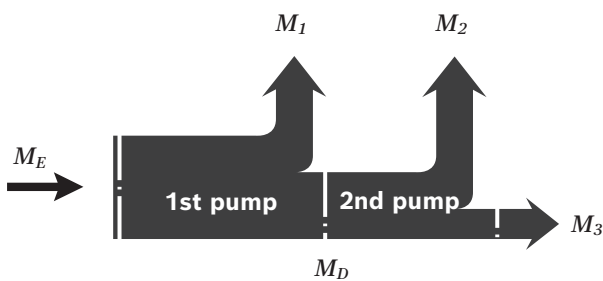
Distribution of torques

Torque at 1st pump	M_1
Torque at 2nd pump	M_2
Torque at 3rd pump	M_3
Input torque	$M_E = M_1 + M_2 + M_3$
	$M_E < M_{E \max}$
Through-drive torque	$M_D = M_2 + M_3$
	$M_D < M_{D \max}$

Notice

- ▶ In case of through drive pumps as well as in case of bi-directional torque loads, the use of a splined shaft is recommended.
- ▶ The through-drive torques apply to the through-drive shaft without hub:
Prepared for through drive, with **pressure-resistant plugged cover** – order code F/K99.
- ▶ The permissible output torques of the supplied hub depend on the drive torques of the attachment pumps:
Overview of mounting options see page 27

1) Efficiency not considered

2) For drive shafts free of radial force

Overview of control devices

HS5 - Control system hydraulic with proportional valve

(see data sheet 92076)

The continuous displacement control is accomplished by means of a proportional valve and electrical feedback of the swivel angle.

The HS5P control system is equipped with a mounted pressure transducer, which means that it can be used for electric pressure and power control.

Optional:

- ▶ with pressure transducer (HS5P)
- ▶ short circuit valve (HS5K, HS5KP)
- ▶ for oil-immersed use (HS5M)
- ▶ internal control pressure supply (HS5(E)L)

▼ Characteristic curve

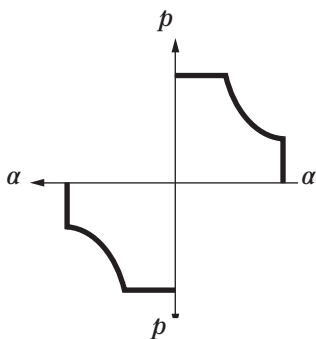

▼ Circuit diagram

Example: A4CSG 250/355 HS5...F..4D

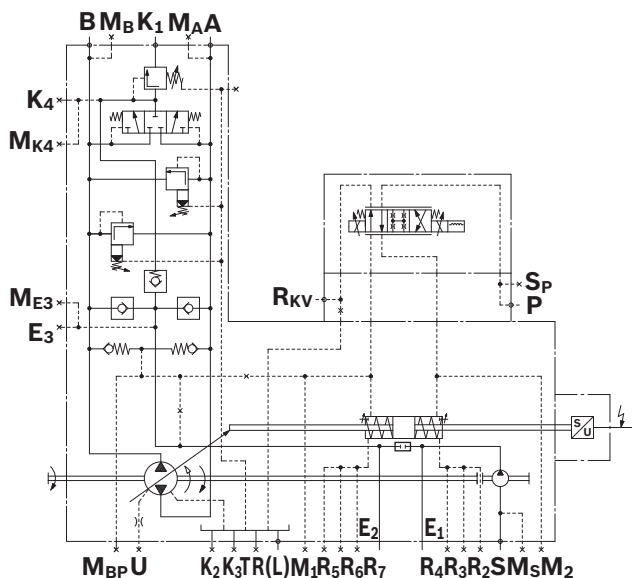

(prepared for customer-specific control system)

(see data sheet 92076)

The HM2C customer solution provides the base unit, sensors and actuators required for a control system. This means that a pump control system can be built up by the end users themselves for electronic volume, pressure and power control.

Notice: No finished pump control electronics is available for the HM2C like for the HS5. The HM2C can be integrated freely in the control architecture of the plant operator machine with defined standard interfaces.

▼ Circuit diagram

Example: A4CSG 250 HM2C...F..4D

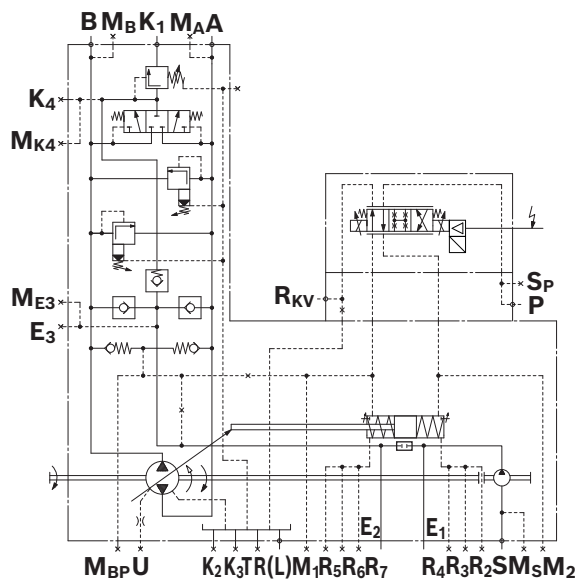

E02 - Control system hydraulic with proportional valve

(see data sheet 92076)

The continuous control of the displacement flow is accomplished by means of a proportional valve and electrical feedback of the swivel angle.

Thus, the control can be used as an electric displacement control.

Optional:

- ▶ Short circuit valve (EO2K)

▼ **Characteristic curve**

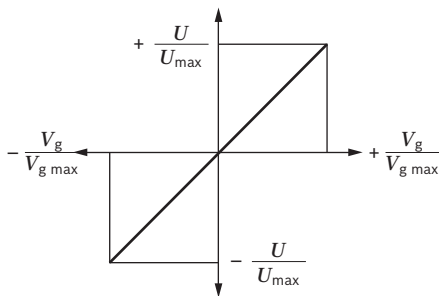

▼ **Circuit diagram**

Example: A4CSG 500/750 EO2...F..4D

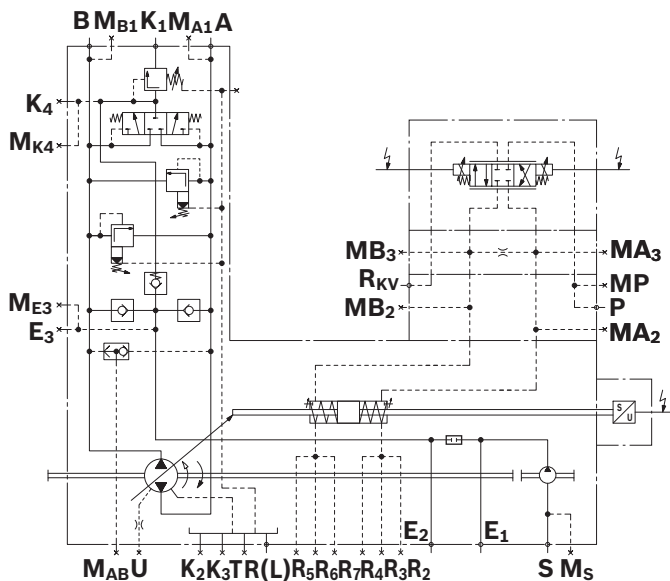

HD - Proportional control, hydraulic, pilot-pressure related (see data sheet 92080)

Stepless setting of the pump displacement according to the pilot pressure. The control is proportional to the specified pilot pressure setpoint value (difference between **X1**, **X2**).

For version **F** with integrated boost pump, the control is supplied internally with the control pressure from the boost circuit. This saves using a separate control pressure pump.

Optional:

- ▶ Control characteristics (HD1, HD2, HD3)
- ▶ Pressure control (HD.A, HD.B, HD.D)
- ▶ Remote pressure control (HD.GA, HD.GB, HD.G)
- ▶ Power control (HD1P)
- ▶ Electrical control of pilot pressure (HD1T)

▼ **Characteristic curve**

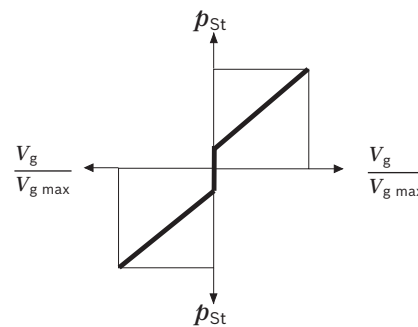

▼ **Circuit diagram**

Example: A4CSG 500/750 HD1...F..4M

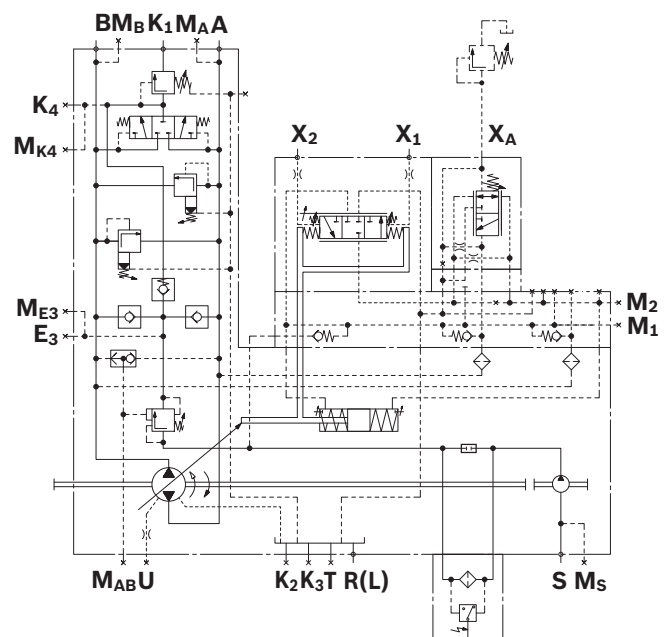

EP – Proportional control, electro-hydraulic

(see data sheet 92084)

The EP control adjusts the pump displacement proportionally to the current at the solenoid. Current-regulated control units with pulse width modulation are recommended for controlling the solenoids. For version **F** with integrated boost pump, the control is supplied internally with the control pressure from the boost circuit. This saves using a separate control pressure pump.

Optional:

- ▶ Pressure control (EPA, EPB, EPD)
- ▶ Remote pressure control (EPGA, EPGB, EPG)

▼ **Characteristic curve**

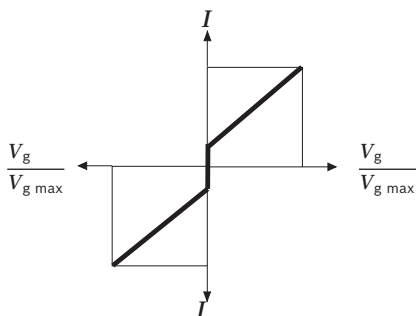

▼ **Circuit diagram**

Example: A4CSG 500/750 EPD...F..4D¹⁾

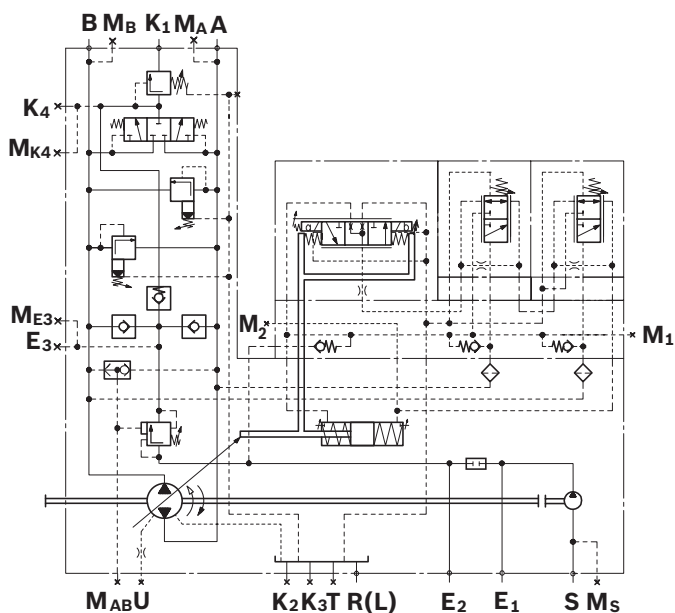

1) Version M with filter, see page 33

Dimensions, size 250

A4CSG250EPG/30R-XXB35F994N

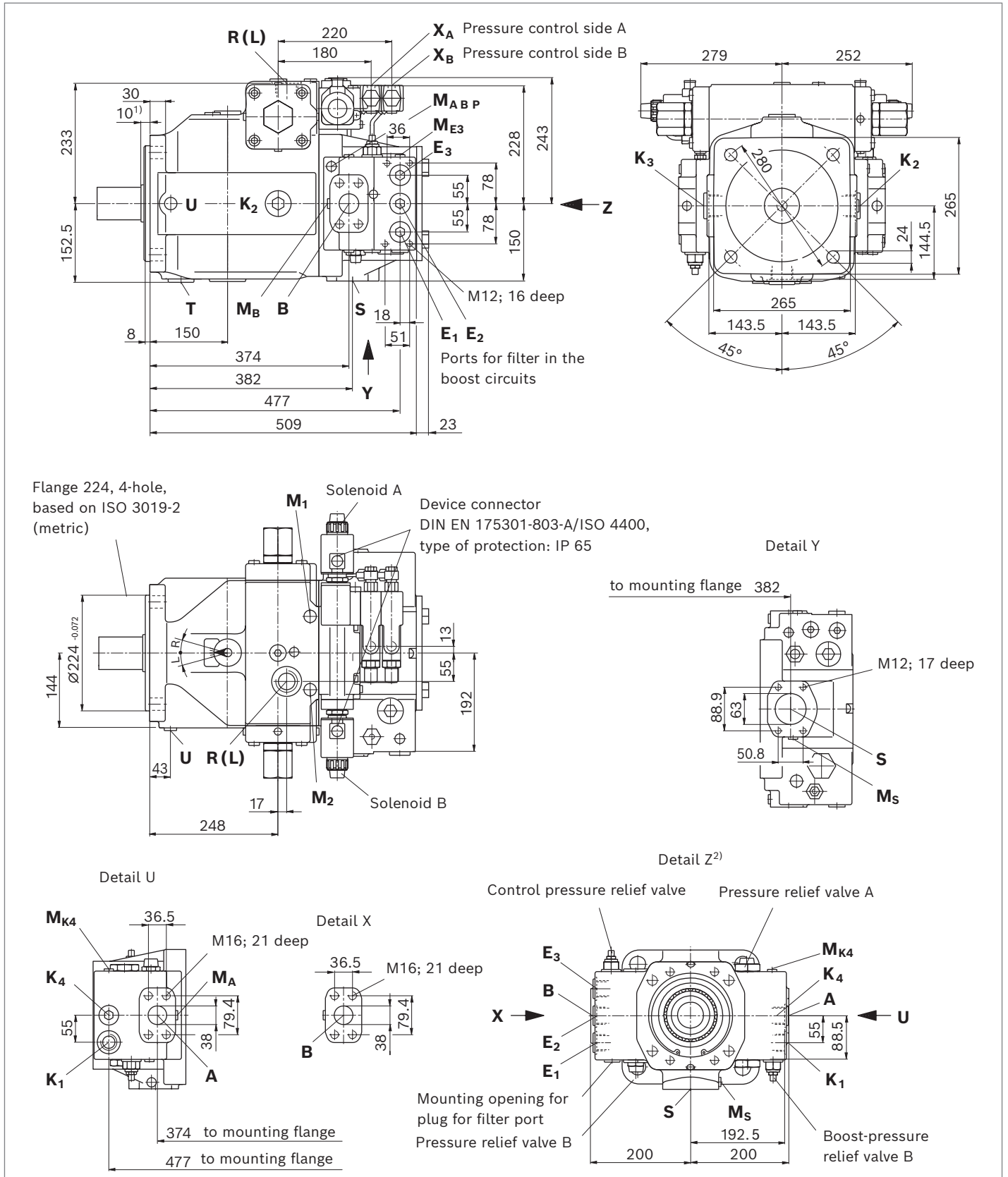

1) to shaft collar

2) F99 through-drive drawn without cover, dimensions page 21

▼ **Parallel keyed shaft DIN 6885**

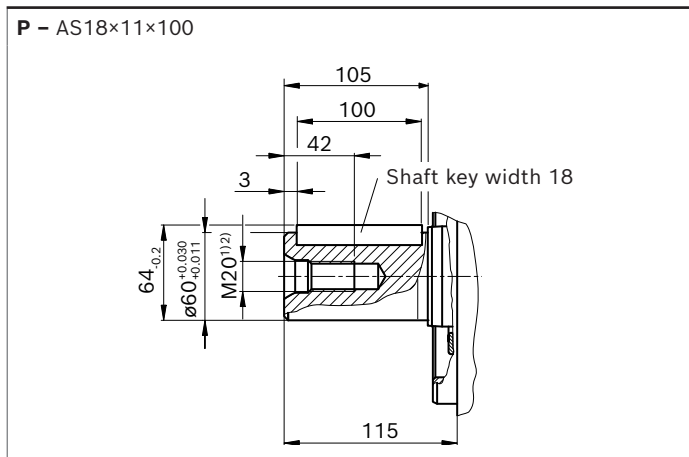

▼ **Splined shaft DIN 5480**

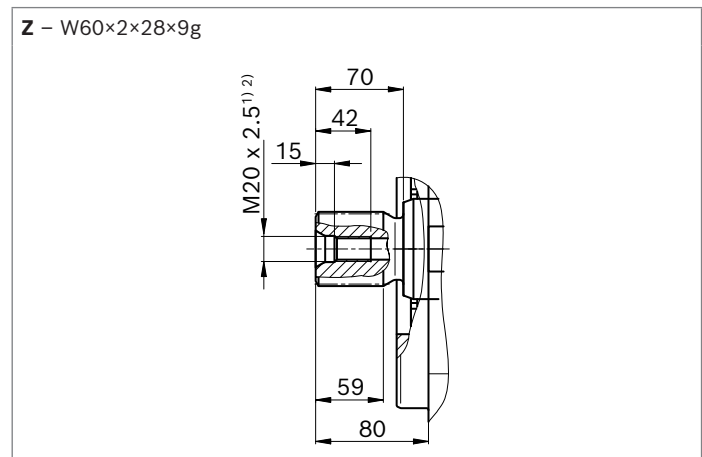

Ports	Standard	Size	p_{max} [bar] ³⁾	State ⁷⁾
A, B	Working port (high-pressure series) Fastening thread A/B	SAE J518 ⁴⁾ DIN 13	1 1/2 in M16 × 2; 24 deep	400 O
S	Suction port (standard pressure series) Fastening thread S	SAE J518 ⁴⁾ DIN 13	2 1/2 in M12 × 1.75; 17 deep	30 O
M_A, M_B, M_{ABP}	Measuring port working pressure A/B	DIN 3852	M14 × 1.5; 12 deep	400 X
M_S	Measuring port suction	DIN 3852	M14 × 1.5; 12 deep	30 X
T	Fluid drain	DIN 3852 ⁵⁾	M42 × 2; 20 deep	4 X ⁶⁾
E₁	Filter, supply	DIN 3852	M33 × 2; 18 deep	40 X
E₂	Filter, return	DIN 3852	M33 × 2; 18 deep	40 X
K₁	Flushing port	DIN 3852	M33 × 2; 18 deep	5 O
K₂, K₃	Fluid filling + air bleeding	DIN 3852 ⁵⁾	M42 × 2; 20 deep	4 X ⁶⁾
R(L)	Return flow (drain port)			4 O ⁶⁾
U	Bearing flushing	DIN 3852 ⁵⁾	M14 × 1.5; 12 deep	7 X
E₃	Boost port	DIN 3852	M33 × 2; 18 deep	40 X
M_{E3}	Boost pressure measuring port	DIN 3852	M14 × 1.5; 12 deep	40 X
K₄	Accumulator port	DIN 3852	M33 × 2; 18 deep	40 X
M_{K4}	Boost pressure measuring port	DIN 3852	M14 × 1.5; 12 deep	40 X
M₁, M₂	Measuring port, control pressure	DIN 3852	M18 × 1.5; 12 deep	400 X
X_A, X_B	Pilot pressure, remote control pressure controller	DIN 3852	M14 × 1.5; 12 deep	350 O

1) Center bore according to DIN 332
 2) Thread according to DIN 13
 3) Depending on the application, momentary pressure peaks can occur. Keep this in mind when selecting measuring devices and fittings.
 4) Metric fastening thread is a deviation from standard.

5) The countersink may be deeper than specified in the standard.
 6) Depending on the installation position **T**, **K₂**, **K₃** or **R(L)** must be connected (see also installation instructions on pages 34 to 36)
 7) O = Must be connected (plugged on delivery)
 X = Plugged (in normal operation)

Dimensions, size 355

A4CSG355EPG/30R-XXB35F994N

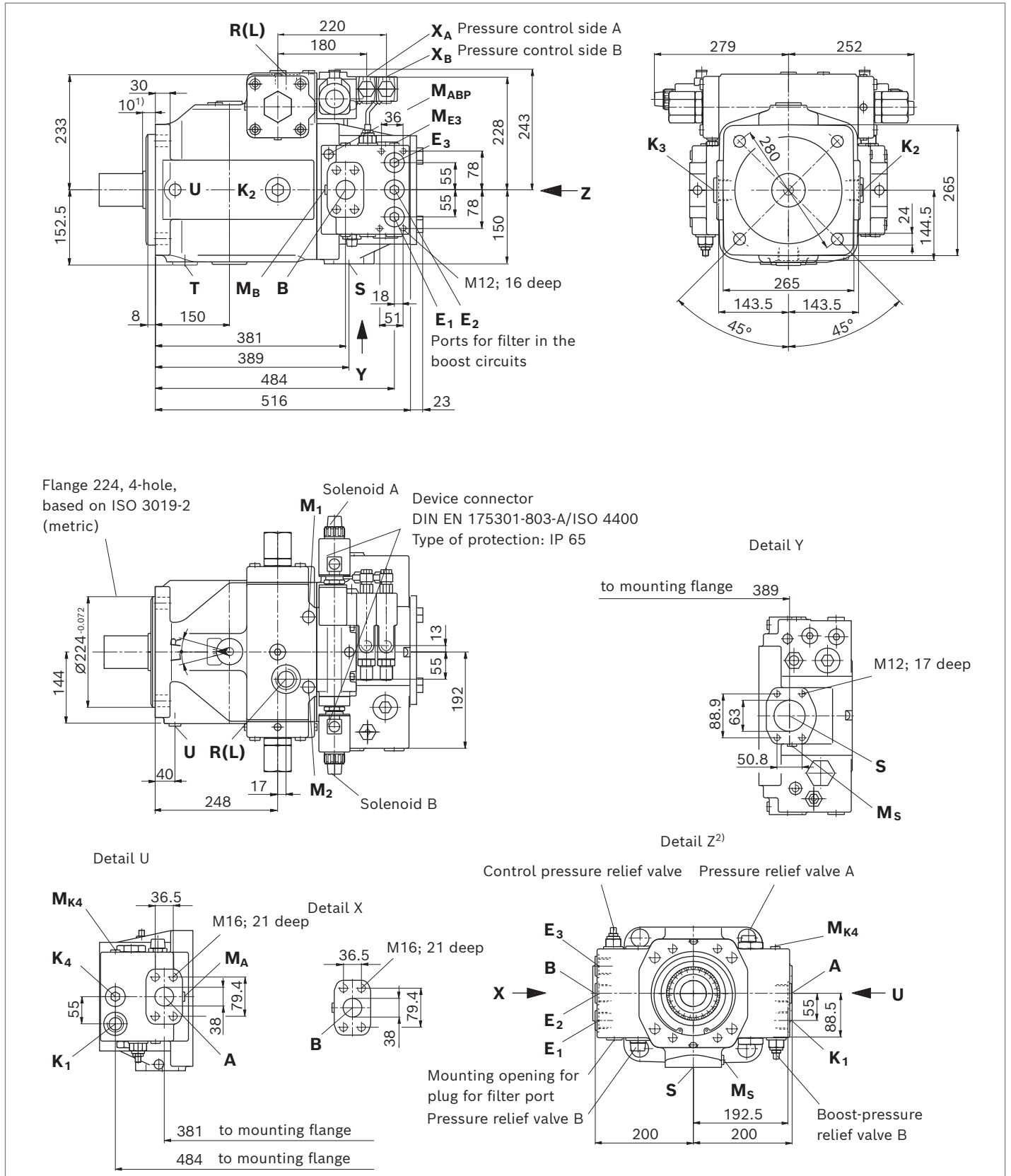

1) to shaft collar
 2) F99 through-drive drawn without cover, dimensions page 21

▼ **Parallel keyed shaft DIN 6885**

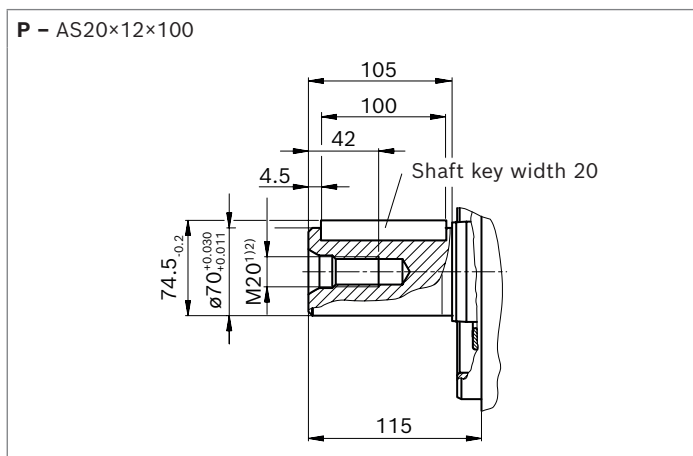

▼ **Splined shaft DIN 5480**

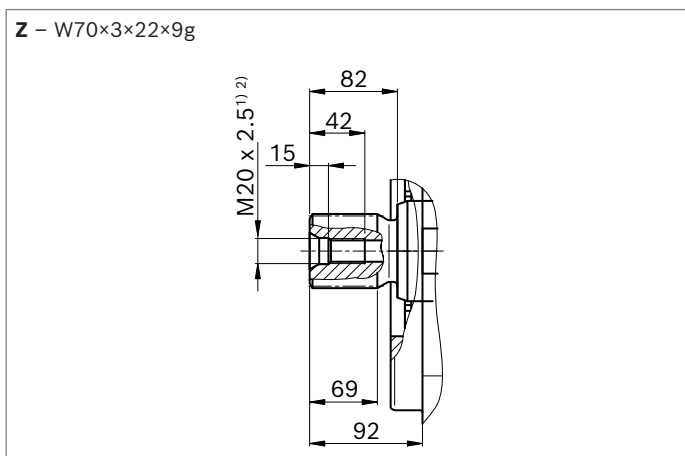

Ports	Standard	Size	p_{max} [bar] ³⁾	State ⁷⁾	
A, B	Working port (high-pressure series)	SAE J518 ⁴⁾	1 1/2 in	400	O
	Fastening thread A/B	DIN 13	M16 × 2; 24 deep		
S	Suction port (standard pressure series)	SAE J518 ⁴⁾	2 1/2 in	30	O
	Fastening thread S	DIN 13	M12 × 1.75; 17 deep		
M_A, M_B, M_{ABP}	Measuring port working pressure A/B	DIN 3852	M14 × 1.5; 12 deep	400	X
M_S	Measuring port suction	DIN 3852	M14 × 1.5; 12 deep	30	X
T	Fluid drain	DIN 3852 ⁵⁾	M42 × 2; 20 deep	4	X ⁶⁾
E₁	Filter, supply	DIN 3852	M33 × 2; 18 deep	40	X
E₂	Filter, return	DIN 3852	M33 × 2; 18 deep	40	X
K₁	Flushing port	DIN 3852	M33 × 2; 18 deep	5	O
K₂, K₃	Fluid filling + air bleeding	DIN 3852 ⁵⁾	M42 × 2; 20 deep	4	X ⁶⁾
R(L)	Return flow (drain port)			4	O ⁶⁾
U	Bearing flushing	DIN 3852 ⁵⁾	M18 × 1.5; 12 deep	7	X
E₃	Boost port	DIN 3852	M33 × 2; 18 deep	40	X
M_{E3}	Boost pressure measuring port	DIN 3852	M14 × 1.5; 12 deep	40	X
K₄	Accumulator port	DIN 3852	M33 × 2; 18 deep	40	X
M_{K4}	Boost pressure measuring port	DIN 3852	M14 × 1.5; 12 deep	40	X
M₁, M₂	Measuring port, control pressure	DIN 3852	M18 × 1.5; 12 deep	400	X
X_A, X_B	Pilot pressure, remote control pressure controller	DIN 3852	M14 × 1.5; 12 deep	350	O

1) Center bore according to DIN 332
 2) Thread according to DIN 13
 3) Depending on the application, momentary pressure peaks can occur. Keep this in mind when selecting measuring devices and fittings.
 4) Only dimensions according to SAE J518, metric fastening thread is a deviation from the standard.

5) The countersink may be deeper than specified in the standard.
 6) Depending on the installation position **T**, **K₂**, **K₃** or **R(L)** must be connected (see also pages 34 to 36)
 7) O = Must be connected (plugged on delivery)
 X = Plugged (in normal operation)

Dimensions, size 500

A4CSG500EPD/30R-XXH35F994N

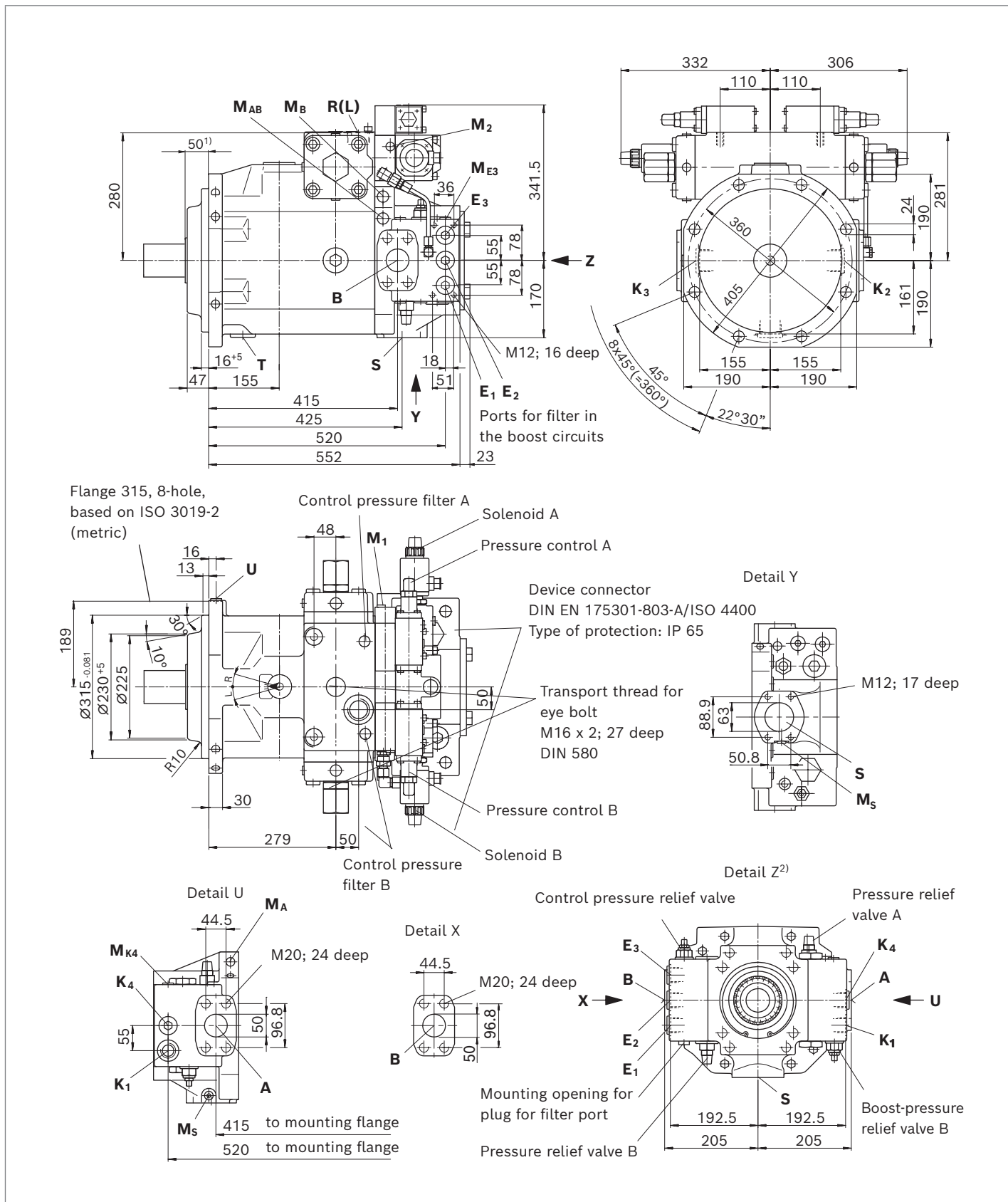

1) to shaft collar
 2) F99 through-drive drawn without cover, dimensions page 21

▼ **Parallel keyed shaft DIN 6885**

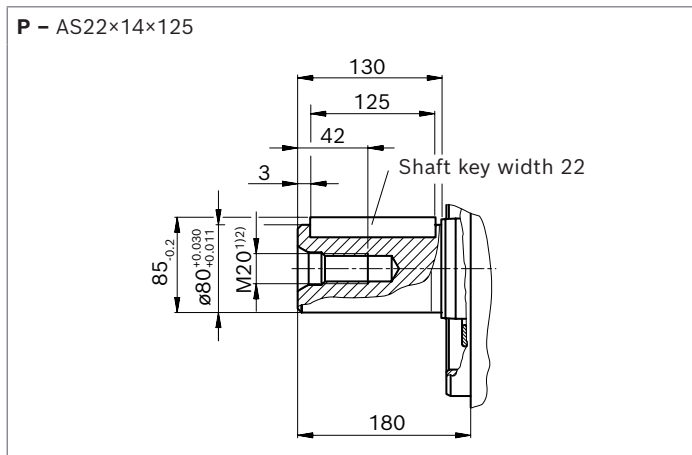

▼ **Splined shaft DIN 5480**

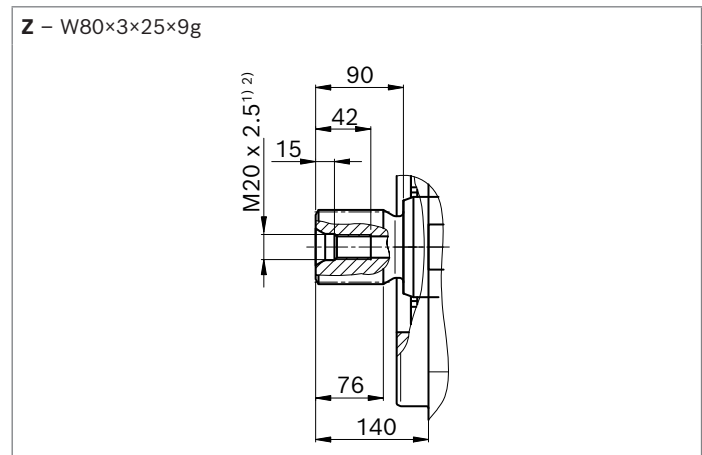

Ports		Standard	Size	p_{max} [bar] ³⁾	State ⁷⁾
A, B	Working port (high-pressure series)	SAE J518 ⁴⁾	2 in	400	O
	Fastening thread A/B	DIN 13	M20 × 2.5; 24 deep		
S	Suction port (standard pressure series)	SAE J518 ⁴⁾	2 1/2 in	30	O
	Fastening thread S	DIN 13	M12 × 1.75; 18 deep		
M_A, M_B, M_{ABP}	Measuring port working pressure A/B	DIN 3852	M14 × 1.5; 12 deep	400	X
M_S	Measuring port suction	DIN 3852	M14 × 1.5; 12 deep	30	X
T	Fluid drain	DIN 3852 ⁵⁾	M48 × 2; 22 deep	4	X ⁶⁾
E₁	Filter, supply	DIN 3852	M33 × 2; 18 deep	40	X
E₂	Filter, return	DIN 3852	M33 × 2; 18 deep	40	X
K₁	Flushing port	DIN 3852	M33 × 2; 18 deep	5	O
K₂, K₃	Fluid filling + air bleeding	DIN 3852 ⁵⁾	M48 × 2; 22 deep	4	X ⁶⁾
R(L)	Return flow (drain port)			4	O ⁶⁾
U	Bearing flushing	DIN 3852 ⁵⁾	M18 × 1.5; 12 deep	7	X
E₃	Boost port	DIN 3852	M33 × 2; 18 deep	40	X
M_{E3}	Boost pressure measuring port	DIN 3852	M14 × 1.5; 12 deep	40	X
K₄	Accumulator port	DIN 3852	M33 × 2; 18 deep	40	X
M_{K4}	Boost pressure measuring port	DIN 3852	M14 × 1.5; 12 deep	40	X
M₁	Measuring port stroking chamber pressure	DIN 3852	M22 × 1.5; 14 deep	400	X
M₂	Measuring port stroking chamber pressure	DIN 3852	M14 × 1.5; 12 deep	400	X
X_A, X_B	Pilot pressure, remote control pressure controller	DIN 3852	M14 × 1.5; 12 deep	350	O

1) Center bore according to DIN 332

2) Thread according to DIN 13

3) Depending on the application, momentary pressure peaks can occur. Keep this in mind when selecting measuring devices and fittings.

4) Only dimensions according to SAE J518, metric fastening thread is a deviation from the standard.

5) The countersink may be deeper than specified in the standard.

6) Depending on the installation position **T**, **K₂**, **K₃** or **R(L)** must be connected (see also pages 34 to 36)

7) O = Must be connected (plugged on delivery)

X = Plugged (in normal operation)

Dimensions, size 750

A4CSG750EPG/30R-XXH35F994N

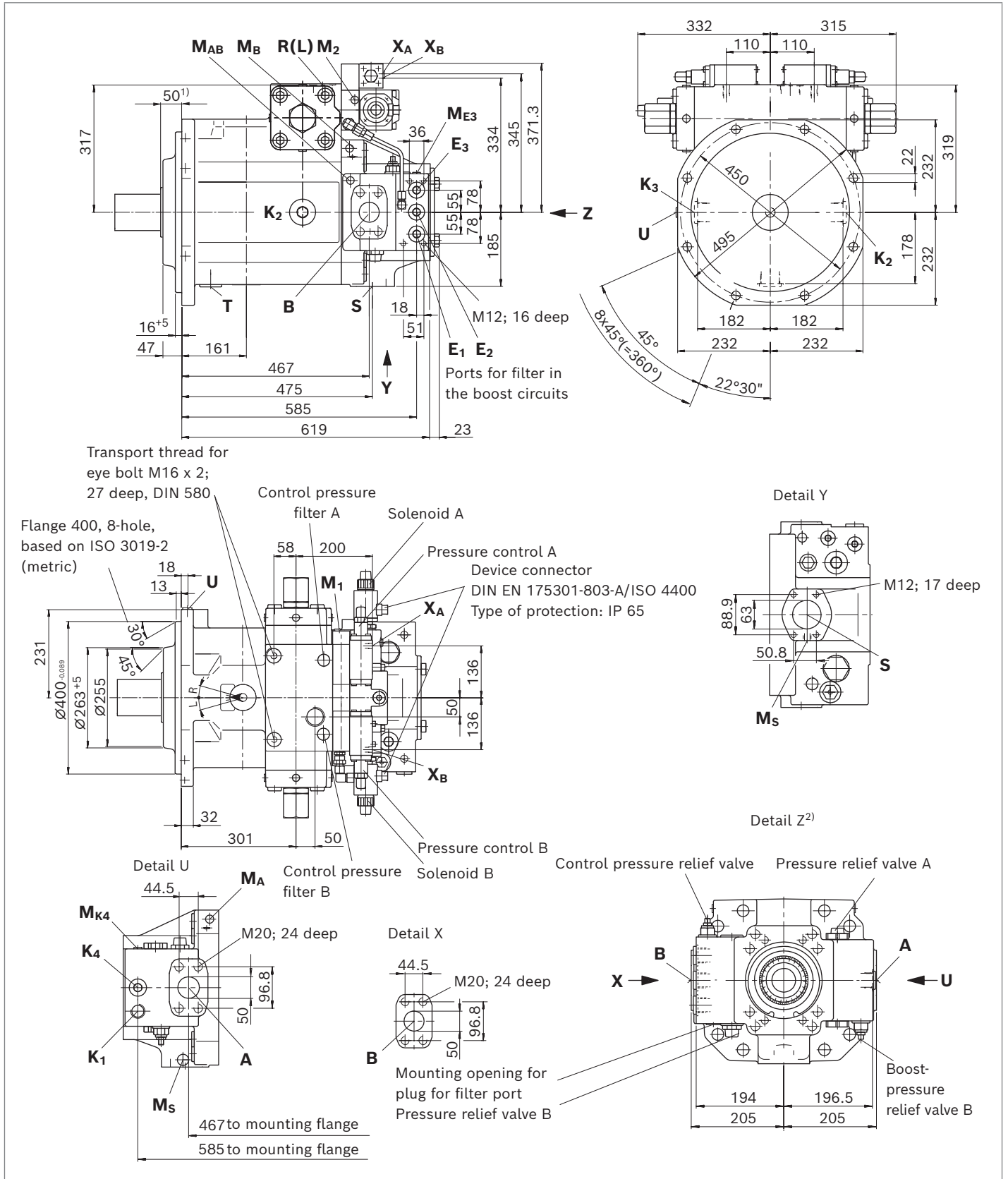

1) to shaft collar

2) F99 through-drive drawn without cover, dimensions page 21

▼ **Parallel keyed shaft DIN 6885**

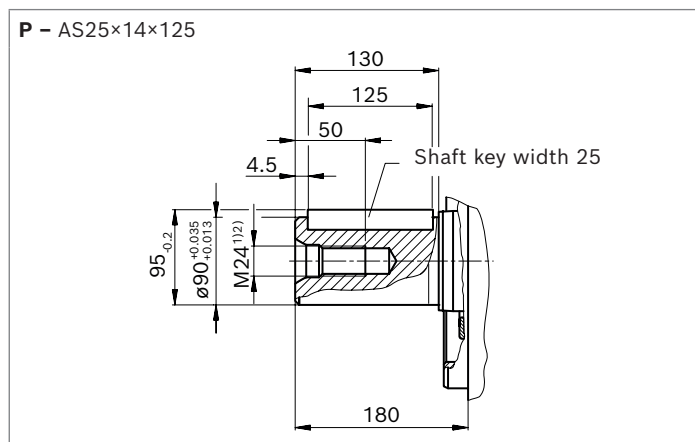

▼ **Splined shaft DIN 5480**

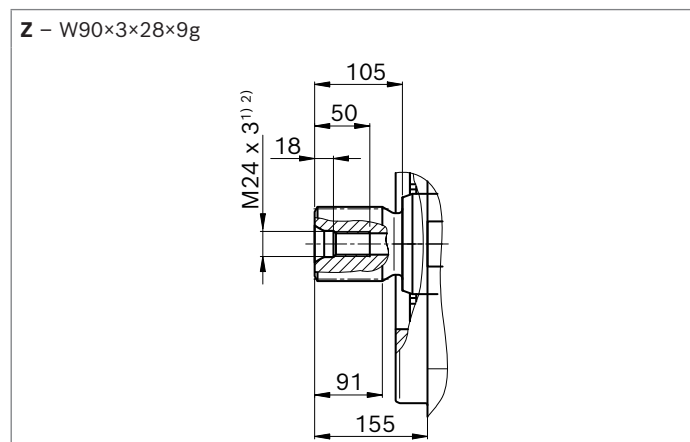

Ports	Standard	Size	p_{max} [bar] ³⁾	State ⁷⁾	
A, B	Working port (high-pressure series) Fastening thread A/B	SAE J518 ⁴⁾ DIN 13	2 in M20 × 2.5; 24 deep	400	O
S	Suction port (standard pressure series) Fastening thread S	SAE J518 ⁴⁾ DIN 13	2 1/2 in M12 × 1.75; 18 deep	30	O
M_A, M_B, M_{ABP}	Measuring port working pressure A/B	DIN 3852	M14 × 1.5; 12 deep	400	X
M_S	Measuring port suction	DIN 3852	M14 × 1.5; 12 deep	30	X
T	Fluid drain	DIN 3852 ⁵⁾	M48 × 2; 22 deep	4	X ⁶⁾
E₁	Filter, supply	DIN 3852	M33 × 2; 18 deep	40	X
E₂	Filter, return	DIN 3852	M33 × 2; 18 deep	40	X
K₁	Flushing port	DIN 3852	M33 × 2; 18 deep	5	O
K₂, K₃	Fluid filling + air bleeding	DIN 3852 ⁵⁾	M48 × 2; 22 deep	4	X ⁶⁾
R(L)	Return flow (drain port)			4	O ⁶⁾
U	Bearing flushing	DIN 3852 ⁵⁾	M18 × 1.5; 12 deep	7	X
E₃	Boost port	DIN 3852	M33 × 2; 18 deep	40	X
M_{E3}	Boost pressure measuring port	DIN 3852	M14 × 1.5; 12 deep	40	X
K₄	Accumulator port	DIN 3852	M33 × 2; 18 deep	40	X
M_{K4}	Boost pressure measuring port	DIN 3852	M14 × 1.5; 12 deep	40	X
M₁	Measuring port stroking chamber pressure	DIN 3852	M22 × 1.5; 14 deep	400	X
M₂	Measuring port stroking chamber pressure	DIN 3852	M14 × 1.5; 12 deep	400	X
X_A, X_B	Pilot pressure, remote control pressure controller	DIN 3852	M14 × 1.5; 12 deep	350	O

1) Center bore according to DIN 332

2) Thread according to DIN 13

3) Depending on the application, momentary pressure peaks can occur. Keep this in mind when selecting measuring devices and fittings.

4) Only dimensions according to SAE J518, metric fastening thread is a deviation from the standard.

5) The countersink may be deeper than specified in the standard.

6) Depending on the installation position **T**, **K₂**, **K₃** or **R(L)** must be connected (see also pages 34 to 36)

7) O = Must be connected (plugged on delivery)

X = Plugged (in normal operation)

Dimensions, through-drive

With through-drive shaft without hub and intermediate flange, plugged with pressure-resistant cover, O-ring included in scope of delivery	Splined shaft DIN 5480	Availability across sizes				Code
	Diameter	250	355	500	750	F/K
	W42×1.25×32×9g	●	●	-	-	99
	W55×1.25×42×9g	-	-	●	●	99

● = Available - = Not available

▼ F/K99

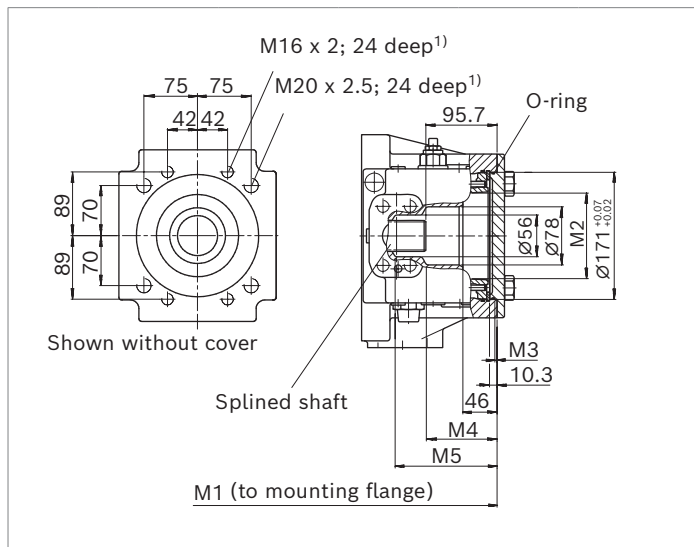

NG	M1	M2	M3	M4	M5
250	509	∅115	3	95	137
355	516	∅115	3	95	137

▼ F/K99

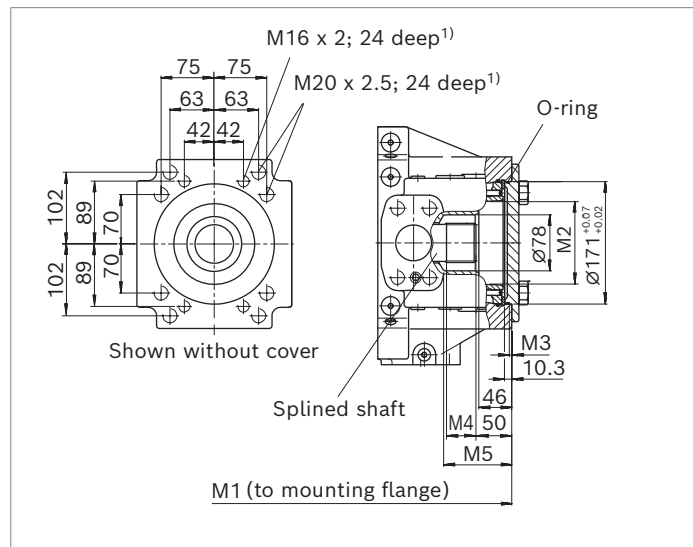

NG	M1	M2	M3	M4	M5
500	552	∅115	3.4	41	95
750	619	∅115	3.4	45	116.6

1) Thread according to DIN 13

Flange ISO 3019-2 (metric)		Hub for splined shaft ¹⁾	Availability across sizes				Code
Diameter	Mounting ²⁾	Diameter	250	355	500	750	F/K
125-4	⊗	W32×2×14×9g	○	●	●	○	31
140-4		W40×2×18×9g	○	○	●	○	33
160-4		W50×2×24×9g	●	●	●	●	34

● = Available ○ = On request

▼ F/K31

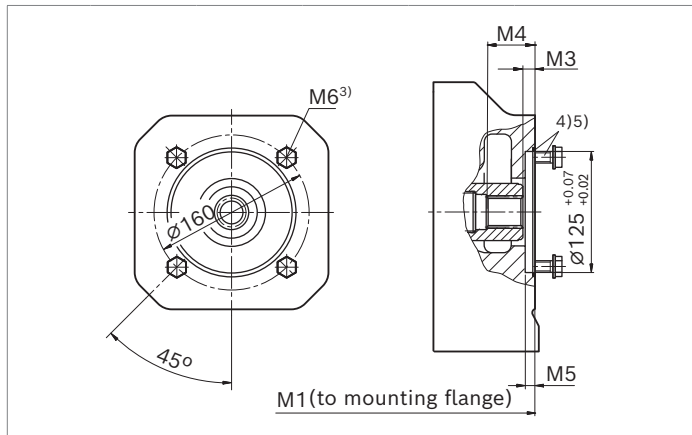

NG	M1	M3	M4	M5	M6
355	539	11.5	46	10	M12; 18 deep
500	575	12.5	51	10	

▼ F/K33

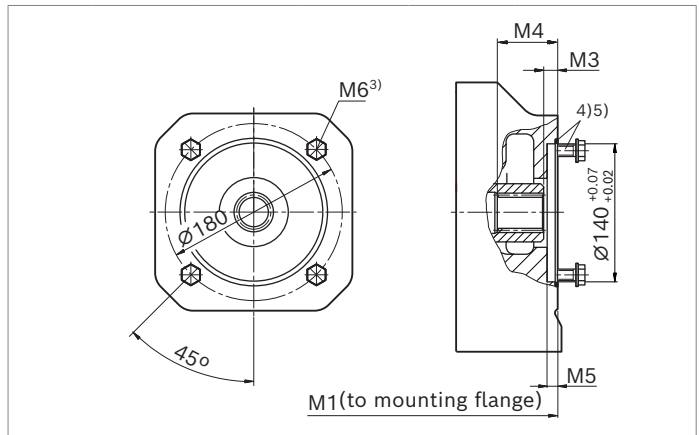

NG	M1	M3	M4	M5	M6
355	541	12.5	60	10	M12; 14.5 deep
500	577	14.5	50	10	

▼ F/K34

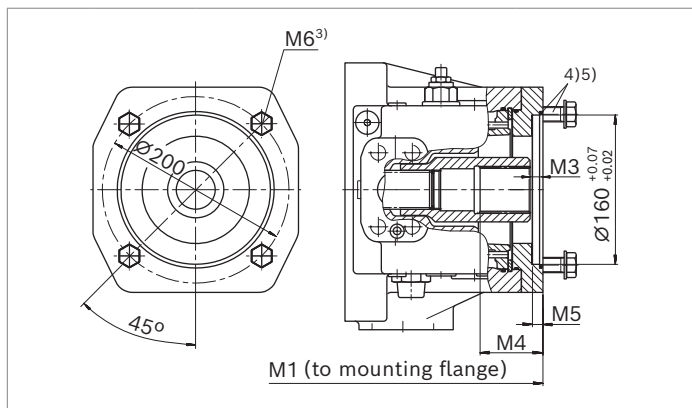

NG	M1	M3	M4	M5	M6
250	531	12.5	66	10	M16; 22 deep
355	538	12.5	66	10	
500	574	12.5	67	10	
750	641	12.5	67	10	

- 1) Splined hub × 8H according to DIN 5480
- 2) Mounting holes pattern viewed on through-drive with control at top
- 3) Thread according to DIN 13
- 4) 4 mounting bolts and O-ring seal are included in the scope of delivery.
- 5) Design recommended according to VDI 2230, screw grade 8.8 according to ISO 898-1

Flange ISO 3019-2 (metric)		Hub for splined shaft ¹⁾	Availability across sizes				Code
Diameter	Mounting ²⁾	Diameter	250	355	500	750	F/K
224-4		W60×2×28×9g	●	○	○	○	35
		W70×3×22×9g	○	●	●	○	77
315-8		W80×3×25×9g	○	○	●	○	43

● = Available ○ = On request

▼ **F/K77**

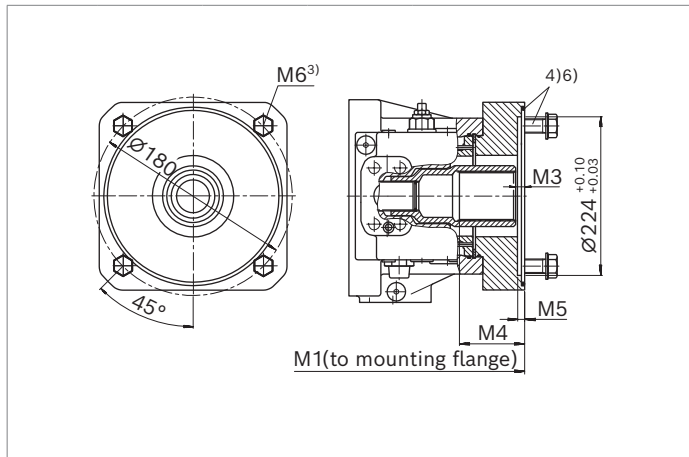

NG	M1	M3	M4	M5	M6
355	575	12.4	92	8	M20; 30 deep
500	611	12.5	94.5	8	

▼ **F/K43**

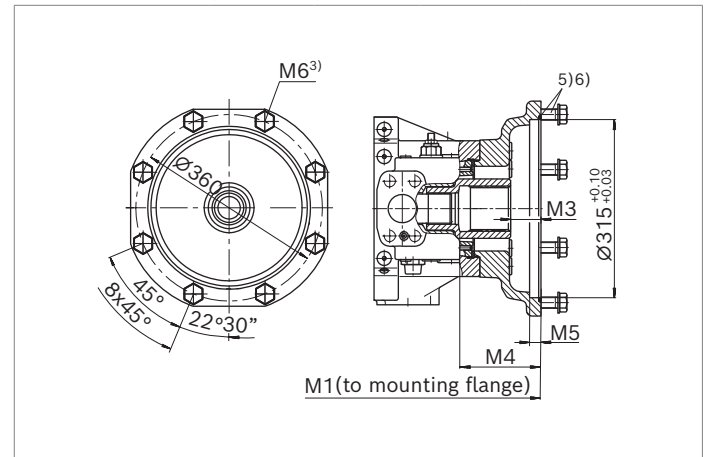

NG	M1	M3	M4	M5	M6
500	660	53.5	143	19	M20; 26 deep

▼ **F/K35**

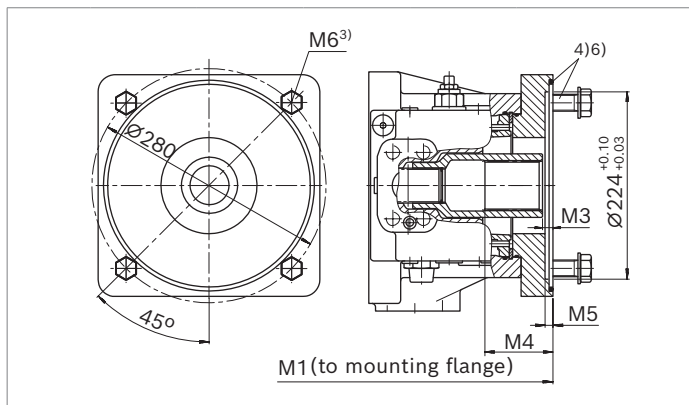

NG	M1	M3	M4	M5	M6
250	547	12.5	81	8	M20; 30 deep
355	554	12.5	81	8	
500	611	12.5	81	8	
750	678	12.5	81	8	

- 1) Splined hub × 8H according to DIN 5480
- 2) Mounting holes pattern viewed on through-drive with control at top
- 3) Thread according to DIN 13
- 4) 4 mounting bolts and O-ring seal are included in the scope of delivery.
- 5) 8 mounting bolts and O-ring seal are included in the scope of delivery.
- 6) Design recommended according to VDI 2230, screw grade 8.8 according to ISO 898-1

Flange ISO 3019-2 (metric)		Hub for splined shaft ¹⁾		Availability across sizes				Code
Diameter	Mounting ²⁾	Diameter		250	355	500	750	F/K
100-2		7/8 in	13T 16/32DP	●	●	○	○	B3
125-2		1 1/4 in	14T 12/24DP	●	○	○	○	B5
		1 1/2 in	17T 12/24DP	○	●	○	○	B6

● = Available ○ = On request

▼ F/KB3

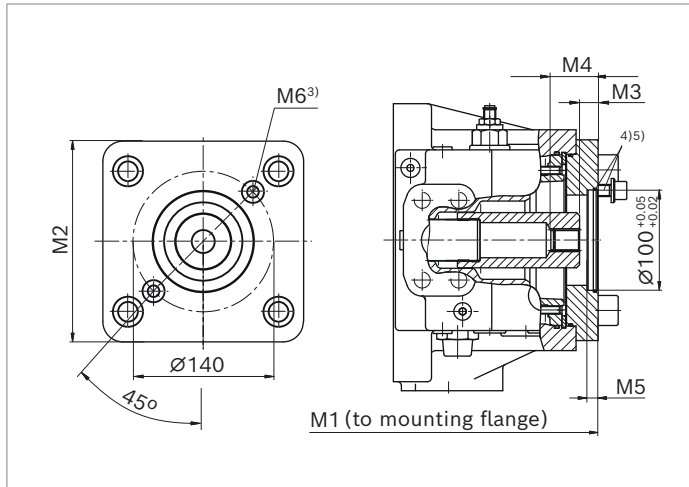

NG	M1	M2	M3	M4	M5	M6
250	531	200	18.5	43.5	10	M12; 18 deep
355	538	200	18.5	43.5	10	

▼ F/KB5

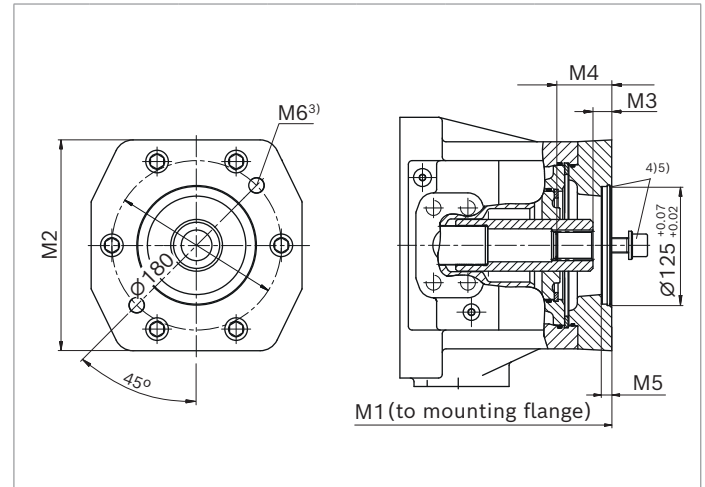

NG	M1	M2	M3	M4	M5	M6
250	545	224	19.9	58	10	M16; 24 deep
355	552	224	19.9	58	10	

▼ F/KB6

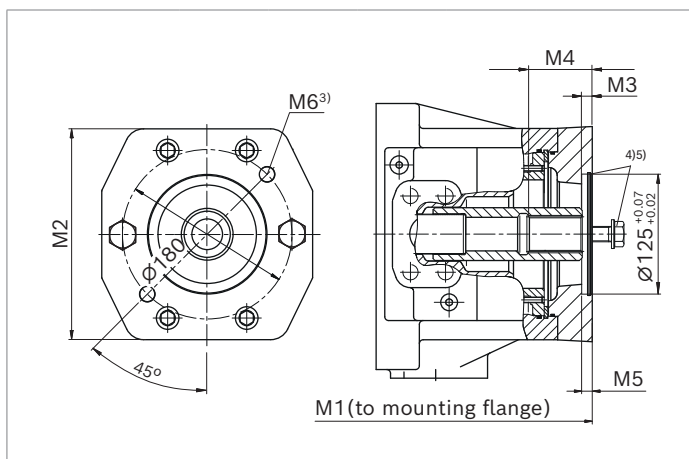

NG	M1	M2	M3	M4	M5	M6
355	552	224	10	66	10.4	M16; 24 deep

- 1) In accordance with ANSI B92.1a, 30° pressure angle, flat root, side fit, tolerance class 5
- 2) Mounting holes pattern viewed on through-drive with control at top
- 3) Thread according to DIN 13
- 4) 2 mounting bolts and O-ring seal are included in the scope of delivery.
- 5) Design recommended according to VDI 2230, screw grade 8.8 according to ISO 898-1

ISO 3019-1 flange (SAEJ744)		Hub for splined shaft ¹⁾	Availability across sizes				Code
Diameter	Mounting ²⁾	Diameter	250	355	500	750	F/K
82-2 (A)		5/8 in 9T 16/32DP	●	●	●	●	01
		3/4 in 11T 16/32DP	○	●	●	○	52
101-2 (B)		7/8 in 13T 16/32DP	●	●	●	○	68
		1 in 15T 16/43DP	○	●	●	○	04

● = Available ○ = On request

▼ F/K01; F/K52

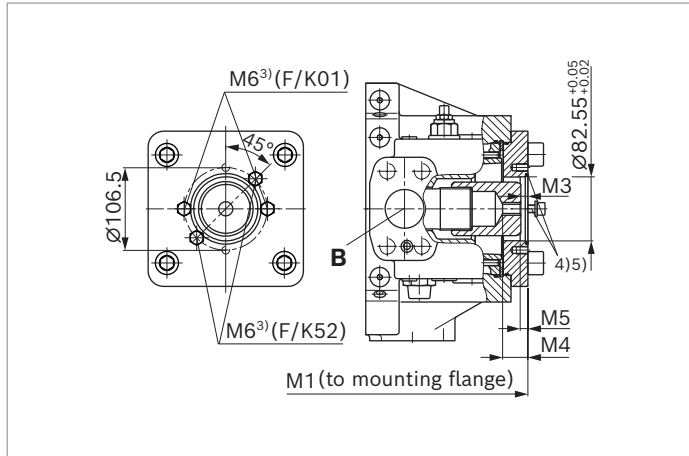

01					
NG	M1	M3	M4	M5	M6
250	531	10.5	33	10	M10; 15 deep
355	538	10.5	33	10	
500	574	9.3	33	10	
750	641	9.3	33	10	

52					
NG	M1	M3	M4	M5	M6
355	531	19.5	40.5	10	M10; 15 deep
500	574	19.5	40.5	10	

▼ F/K68; F/K04

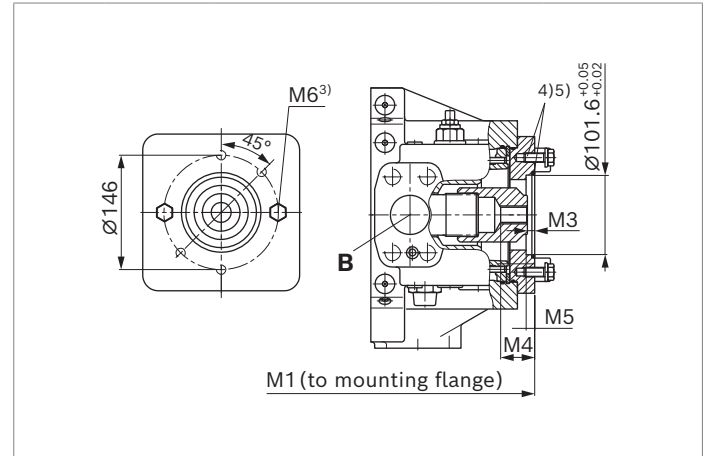

68					
NG	M1	M3	M4	M5	M6
250	531	18.5	43.5	10	M12; 15 deep
355	538	18.5	43.5	10	
500	574	18.5	43.5	10	

04					
NG	M1	M3	M4	M5	M6
355	538	18.9	48.4	10	M12; 15 deep
500	574	19.4	48.4	10	

1) In accordance with ANSI B92.1a, 30° pressure angle, flat root, side fit, tolerance class 5
 2) Mounting holes pattern viewed on through-drive with control at top
 3) Thread according to DIN 13

4) 2 mounting bolts and O-ring seal are included in the scope of delivery.
 5) Design recommended according to VDI 2230, screw grade 8.8 according to ISO 898-1

ISO 3019-1 flange (SAEJ744)		Hub for splined shaft ¹⁾		Availability across sizes				Code
Diameter	Mounting ²⁾	Diameter		250	355	500	750	F/K
127-2 (C)		1 1/4 in	14T 12/24DP	●	●	●	○	07
		1 1/2 in	17T 12/24DP	○	●	●	○	24
152-4 (D)		1 3/4 in	13T 8/16DP	●	●	●	●	17

● = Available ○ = On request

▼ F/K07; F/K24

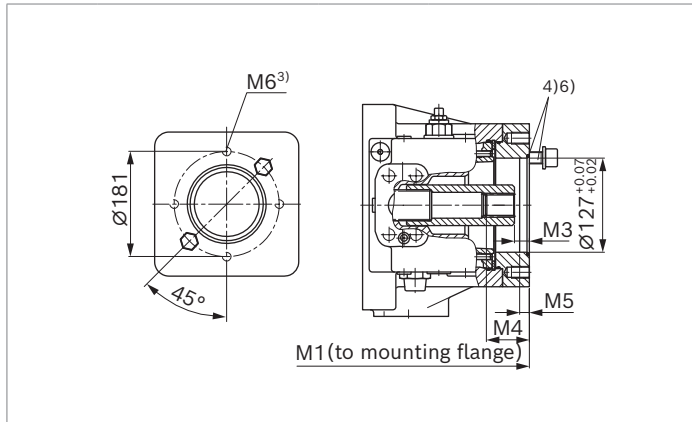

07					
NG	M1	M3	M4	M5	M6
250	545	19.9	58	13	
355	552	19.9	58	13	M16; 24 deep
500	588	18.3	58	13	

24					
NG	M1	M3	M4	M5	M6
250	545	10.4	75	13	
355	552	10.4	75	13	M16; 24 deep
500	588	10.3	67	13	

▼ F/K17

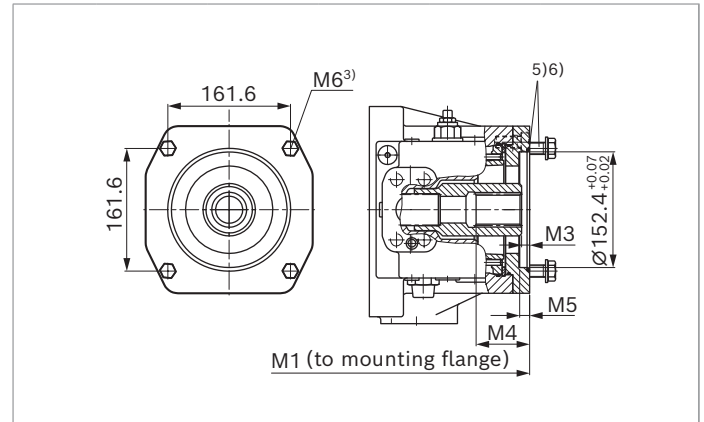

17					
NG	M1	M3	M4	M5	M6
250	531	10.4	73	13	
355	538	10.4	73	13	M16; 22 deep
500	600	10.4	73	13	
750	667	10.4	73	13	M16; 32 deep

1) In accordance with ANSI B92.1a, 30° pressure angle, flat root, side fit, tolerance class 5
 2) Mounting holes pattern viewed on through-drive with control at top
 3) Thread according to DIN 13

4) 2 mounting bolts and O-ring seal are included in the scope of delivery.
 5) 4 mounting bolts and O-ring seal are included in the scope of delivery.
 6) Design recommended according to VDI 2230, screw grade 8.8 according to ISO 898-1

Overview of mounting options on A4CSG

Through-drive - A4CSG			Mounting option 2nd pump				
Flange	Hub for splined shaft ¹⁾	Code	A4CSG NG (shaft)	A4VSO/G NG (shaft)	A10V(S)O/31/32 NG (shaft)	A10V(S)O/52/53 NG (shaft)	External/internal gear pump
Flange ISO 3019-2 (metric)							
80, 2-hole	3/4 in (19-4)	F/KB2	–	–	18 (S, R)/31	10 (S)	–
100, 2-hole	7/8 in (22-4)	F/KB3	–	–	28 (S, R)/31	–	–
	1 in (25-4)	F/KB4	–	–	45 (S, R)/31	–	–
125, 2-hole	1 1/4 in (32-4)	F/KB5	–	–	71, 88 (S, R)/31	–	–
	1 1/2 in (38-4)	F/KB6	–	–	100 (S)/31	–	–
125, 4-hole	W32	F/K31	–	40 (Z)	–	–	–
125, 4-hole	1 in (25-4)	F/KE1	–	–	45 (S)/32	–	–
140, 4-hole	W40	F/K33	–	71 (Z)	–	–	–
160, 4-hole	W50	F/K34	–	125, 180 (Z)	–	–	–
	1 1/4 in (32-4)	F/KB8	–	–	71, 88 (S, R)/32	–	–
180, 4-hole	1 1/2 in (38-4)	F/KB9	–	–	100 (S)/32	–	–
	1 3/4 in (44-4)	F/KB7	–	–	140 (S)/31/32	–	–
224, 4-hole	W60	F/K35	250 (Z)	250 (Z)	–	–	–
	W70	F/K77	355 (Z)	355 (Z)	–	–	–
315, 8-hole	W80	F/K43	500 (Z)	500 (Z)	–	–	–
400, 8-hole	W90	F/K76	750 (Z)	750 (Z)	–	–	–
Flange SAE J744 (ISO 3019-1)²⁾							
82-2 (A)	5/8 in (16-4)	F/K01	–	–	–	–	AZPF-1X-004 to 022 ³⁾
	3/4 in (19-4)	F/K52	–	–	18 (S, R)/31	10 (S)	–
101-2 (B)	7/8 in (22-4)	F/K68	–	–	28 (S, R)/31	28 (S)	AZPN-1X-020 to 032 ³⁾
	1 in (25-4)	F/K04	–	–	45 (S)/31	45 (S)	PGH4
127-2 (C)	1 1/4 in (32-4)	F/K07	–	–	71, 88 (S)/31	–	–
	1 1/2 in (38-4)	F/K24	–	–	100 (S)/31	85 (S)	PGH5
127-4 (C)	1 1/4 in (32-4)	F/KE15	–	–	71, 88 (S)/32	–	–
152-4 (D)	1 3/4 in (44-4)	F/K17	–	–	140 (S)/31	–	–

1) According to DIN 5480 (e.g. W32) or according to SAE J744 (e.g. 3/4 in)

2) 2 = 2-hole, 4 = 4-hole

3) Bosch Rexroth recommends special versions of the gear pumps. Please contact us.

Combination pumps

By using combination pumps, it is possible to have independent circuits without the need for splitter gearboxes.

The variable pump A4CSG can be supplied with through-drive despite the integrated boost pump, in accordance with the type code on page 3.

When ordering combination pumps the type designations for the first and the second pump must be joined by a "+" and are combined into one part number. Each single pump should be ordered according to type code.

Notice

- ▶ The combination pump type code is shown in shortened form in the order confirmation.

Example:

A4CSG 500EPG/30R+A4CSG 500EPG/30R

- ▶ Each through-drive (except for F/K99) is plugged with a **non-pressure-resistant** cover. This means the units must be sealed with a pressure-resistant cover before commissioning. Through drives can also be ordered with a pressure-resistant cover. Please specify in plain text.

A tandem pump, with two pumps of equal size, is permissible without additional supports, assuming that the dynamic mass acceleration does not exceed maximum $10 g (= 98.1 \text{ m/s}^2)$.

For combination pumps consisting of more than two pumps, a calculation of the mounting flange regarding the permissible mass torque is required (please contact us).

For through-drives **F/K01, 04, 07, 24, 52, 68** and **B6**, various possible attachment angle positions are available. As standard, the second pump is mounted at the same angle as the supplied screws are shown in the drawing on pages 23 to 26.

If this angle differs, please contact us.

If a **gear pump** is to be **mounted at the factory as an attachment pump**, please contact us.

Maximum permissible drive and through-drive torques, see page 9.

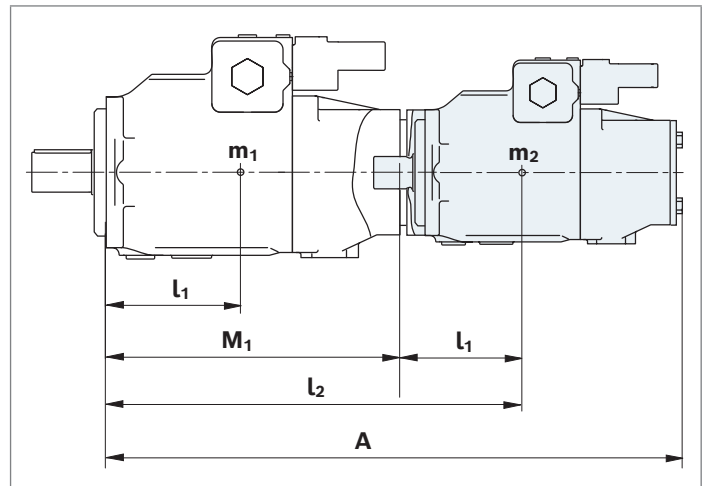

m_1, m_2, m_3	Weight of pump	[kg]
l_1, l_2, l_3	Distance from center of gravity	[mm]
$T_m = (m_1 \cdot l_1 + m_2 \cdot l_2 + m_3 \cdot l_3) \cdot \frac{1}{102}$		[Nm]

Calculation for multiple pumps

l_1 = Front pump distance from center of gravity (values from "Permissible moments of inertia" table)

l_2 = Dimension "M1" from through-drive drawings (page 21 to 26) + l_1 of the 2nd pump

l_3 = Dimension "M1" from through-drive drawings (page 21 to 26) of the 1st pump + "M1" of the 2nd pump + l_1 of the 3rd pump

Total length A

A4CSG (Pump 1)	A4CSG (2nd pump with F/K99 through-drive, without filter)			
	NG250	NG355	NG500	NG750
NG250	1079	–	–	–
NG355	1086	1114	–	–
NG500	1143	1150	1235	–
NG750	1210	1217	1302	1396

Permissible mass moment of inertia

Size			250	355	500	750
Permissible mass moment of inertia	M_m	Nm	9300	9300	15600	19500
Permissible mass moment of inertia with dynamic mass acceleration $10 g = 98.1 \text{ m/s}^2$	M_m	Nm	930	930	1560	1950
Ground	m_1	kg	260	275	390	520
Distance from center of gravity	l_1	mm	270	280	300	330

Integrated boost pump and integrated valve technology (version F..)

High-pressure relief valves (pos. 5)

Two pilot operated pressure relief valves use pressure limitation to prevent damage to the hydraulic pump resulting from overpressure. A pressure relief valve is assigned to each pressure side.

Protection is provided by reducing the high pressure to the low-pressure side.

Pressure limitation is set by default to 350 bar. If another setting is required, please state this in the plain text.

Boost-pressure relief valve (pos. 3), direct operated

The boost pressure can be set on the boost-pressure relief valve.

Boost pressure

To prevent damage to the system, low pressure protection is recommended, which monitors the static pressure component. The ports **M_{E3}** or **M_{K4}**, for example, are suitable for low pressure monitoring. To prevent any impermissible drop in boost pressure, Bosch Rexroth recommends a low pressure accumulator to be connected to the ports **E₂**, **E₃** or **K₄**. The design of the accumulator and the choice of the optimum connection location must be selected according to the hydraulic transmission behavior of the system and the operating conditions, taking the available boost volume into account. Depending on the quantity of system case drain fluid, it may be necessary to increase the boost volume with a larger or additional boost pump.

Integrated boost pump (pos. 9)

Standard size

NG	250	355	500	750
cm ³	63 ¹⁾	80 ¹⁾	98	143

1) Larger boost pumps available on request

Control pressure relief valve (for EP and HD) (pos. 8)

Direct operated, high-pressure-related relief

At low working pressure, the auxiliary pump pressure is regulated to the set the value (e.g. 32 bar). This pressure is needed by the HD and EP controls to swivel out reliably. Using this valve saves the use of a separate control pressure pump.

If the working pressure exceeds the pressure of the boost pump, control is provided by the check valve via the high pressure. At the same time, the increase in working pressure relieves the control pressure relief valve. This reduces the boost pump pressure to the set boost pressure (e.g. 16 bar).

This function leads to energy savings, improved efficiency and a longer service life of the auxiliary pump.

For settings, see page 6.

The control pressure relief valve is not required for the other control devices and is replaced with a threaded plug.

Control fluid filter (pos. 10)

The HD and EP controls of size 500 and 750 with internal control pressure supply from the high pressure are equipped with 0.2 mm coarse dirt filters as standard (independently of the filtration order designation) Dimensions as shown on pages 13 to 19. See circuit diagram on page 30.

Flushing valve (pos. 4)

To open the flushing valve safely, the pressure differential shown in the diagram between **A** and **B** is necessary.

The required pressure differential depends on the rotational speed and the size. The circuit temperature needs to be monitored to avoid any damage to the system.

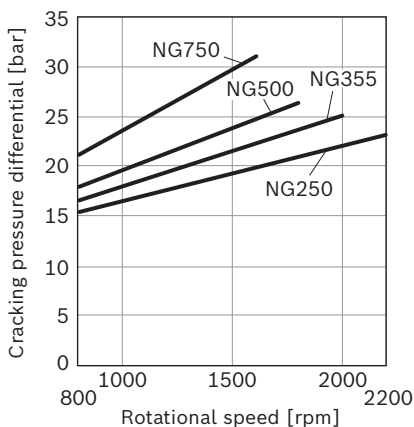

▼ **Circuit diagram**

Example A4CSG...EPG...F..4N (without filters)

Sizes 500 and 750. Additional sizes available on request.

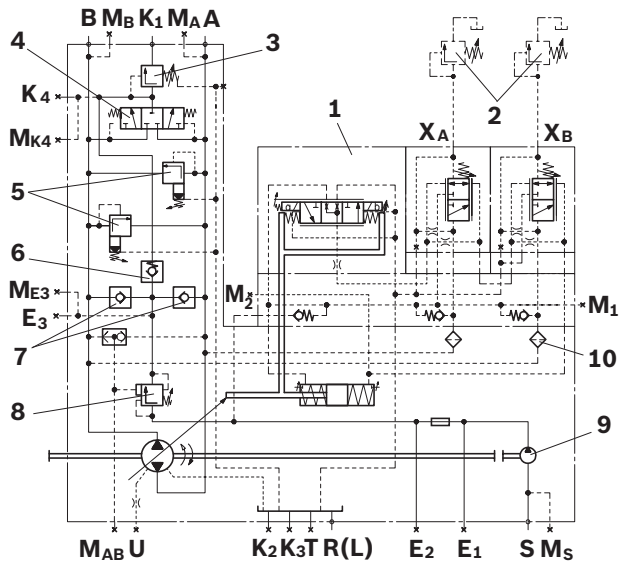

Components	
1	EPG control
2	Pressure relief valves (not included in the scope of delivery)
3	Boost-pressure relief valve
4	Flushing valve
5	High-pressure relief valves
6	Bypass valve
7	Boost check valves
8	Control pressure relief valve
9	Integrated boost pump
10	Control fluid filter for HD and EP (NG 500 and 750)

Circuit diagram NG 500/750 with filter see page 32;
without integrated boost pump see page 30

Ports		p_{max} [bar]	State
A, B	Working line (pressure port)	400	O
S	Suction port	30	O
MA, MB, MAB	Measuring working pressure A/B	400	X
MS	Measuring suction	30	X
T	Fluid drain	4	X
E1	Filter, supply	40	X
E2	Filter, return	40	X
K1	Flushing port	5	O
K2, K3	Fluid filling + air bleeding	4	X
R(L)	Return flow (drain port)	4	O
U	Bearing flushing	7	X
E3	Boost pressure supply	40	X
ME3	Measuring boost pressure	40	X
K4	Accumulator port	40	X
MK4	Measuring boost pressure	40	X
M1	Measurement of stroking chamber pressure	400	X
M2	Measurement of stroking chamber pressure	400	X
XA, XB	Pilot pressure, remote control pressure controller	350	O

External boost pressure supply

Without integrated boost pump (version K..)

For external boost pressure supply, the port **E** (or **E₂** for version K...N/D without filter) is provided and must be connected.

To ensure functional reliability, maintain the required cleanliness level for the boost pressure fluid fed in at port **E/E₂** (see page 5) and observe the boost pressure values (see page 6).

Dimensions, size 500

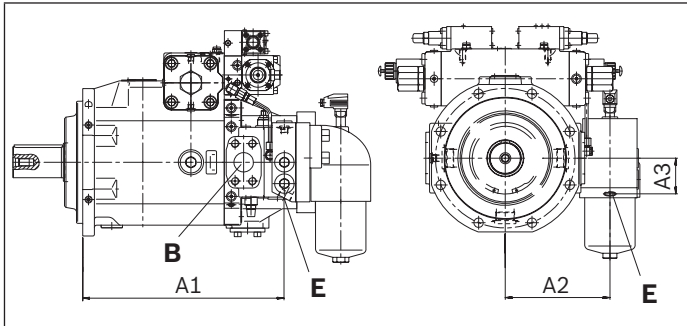

See page 31 for the position and dimensions of port **E₂**.

NG	A1	A2	A3	Port E	Standard
250	477	270	92	M33 × 2; 18 deep	DIN 3852
355	484	270	92	M33 × 2; 18 deep	DIN 3852
500	520	270	92	M33 × 2; 18 deep	DIN 3852
750	585	270	92	M33 × 2; 18 deep	DIN 3852

Ports		<i>p</i> _{max} [bar]	State
E	Boost pressure supply for version with filter	40	O
E₂	Boost pressure supply for version without filter	40	O
A, B	Working line (pressure port)	400	O
S	Suction port (only for version F)	30	O
M_A, M_B, M_{AB}	Measuring working pressure A/B	400	X
M_S	Measuring suction	30	X
T	Fluid drain	4	X
E₁	Filter, supply	40	X
E₂	Filter, return (for version with filter)	40	X
K₁	Flushing port	5	O
K₂, K₃	Fluid filling + air bleeding	4	X
R(L)	Return flow (drain port)	4	O
U	Bearing flushing	7	X
E₃	Boost pressure supply	40	X
M_{E3}	Measuring boost pressure	40	X
K₄	Accumulator port	40	X
M_{K4}	Measuring boost pressure	40	X
M₁	Measurement of stroking chamber pressure	400	X
M₂	Measurement of stroking chamber pressure	400	X

Circuit diagram

Example A4CSG...EPD...K..4M

Sizes **500** and **750**. Additional sizes available on request.

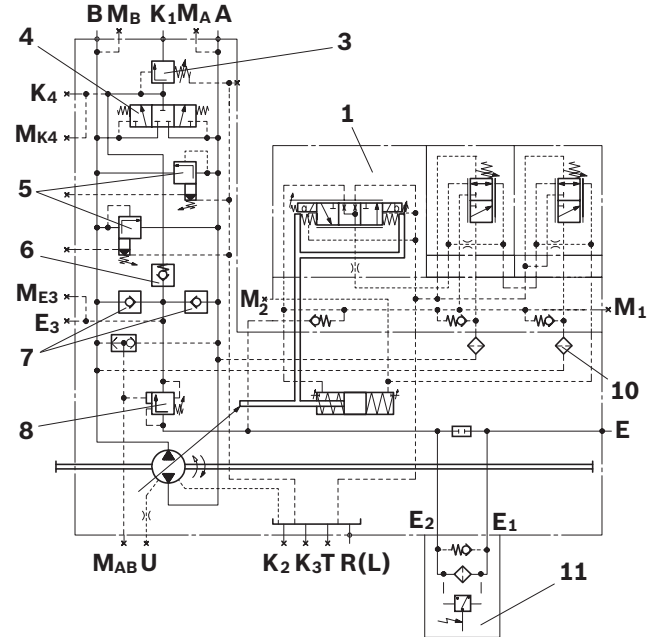

Components

- 1 EP control
- 3 Boost-pressure relief valve
- 4 Flushing valve
- 5 High-pressure relief valves
- 6 Bypass valve
- 7 Boost check valves
- 8 Control pressure relief valve
- 10 Control fluid filter for HD and EP (NG 500 and 750)
- 11 Filter with bypass

Filtration types

Regardless of the selected boost circuit filtration, the HD and EP controls in sizes 500 and 750 are equipped with 0.2 mm control fluid coarse dirt filters as standard (see circuit diagram).

Without filter in the boost circuit (version N)

Ports **E₁** and **E₂** are delivered plugged, pressure-proof and internally connected.

A boost circuit filter can be connected to these ports later on.

The internal passage between **E₁** and **E₂** must be plugged for this purpose (please contact us).

See pages 13 to 19 for dimensions.

See circuit diagram on page 30.

Ports for external boost circuit filtration (version D)

Ports **E₁** and **E₂** are intended for a filter port.

These ports are open and are only plugged with plastic screws for transportation.

The internal passage between **E₁** and **E₂** is plugged.

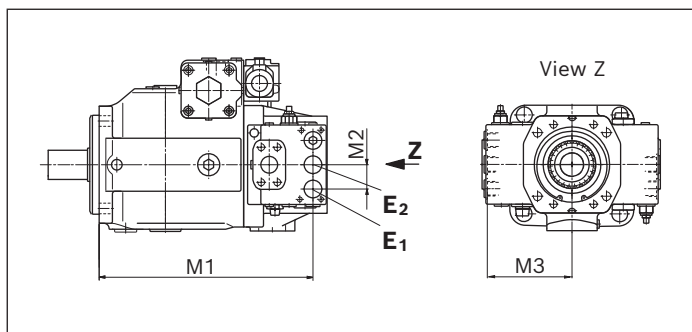

NG	M1	M2	M3	Port E1/E2	Standard
250	477	55	193	M33 × 2; 18 deep	DIN 3852
355	484	55	193	M33 × 2; 18 deep	DIN 3852
500	520	55	193	M33 × 2; 18 deep	DIN 3852
750	585	55	194	M33 × 2; 18 deep	DIN 3852

Ports		p_{max} [bar]	State
E1	Filter, supply	50	○
E2	Filter, return	50	○

Circuit diagram¹⁾

Example A4CSG...EPD...F..4D

Sizes 500 and 750. Additional sizes available on request.

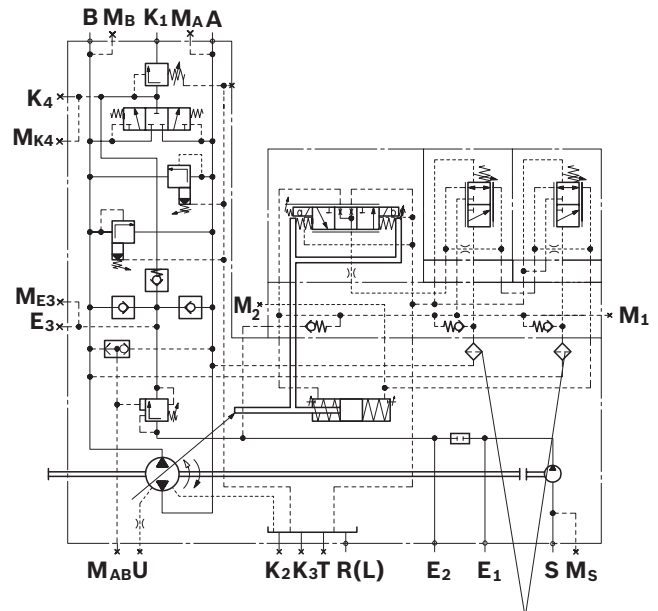

Control fluid filter for HD and EP (nominal sizes 500 and 750)

1) For components and ports, see page 31

With mounted filter in the boost circuit (version M)

A filter is mounted directly to the pump in the pressure line of the boost pump; the internal connection between **E₁** and **E₂** is plugged.

Filter version: type DFBN/HC330QE10D1.X/V-L24

Filter with bypass and optical-electrical contamination indicator

Response pressure of the contamination indicator

$$\Delta p_a = 5 \text{ bar} - 0.5 \text{ bar}$$

$$\text{Cracking pressure of the bypass valve } \Delta p_{\phi} = 6 \text{ bar} + 0.6 \text{ bar}$$

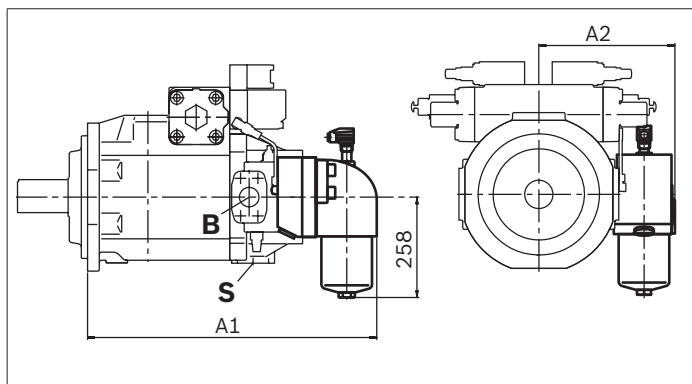

Size	A1	A2
250	699.5	200
355	706.5	347
500	742.5	
750		

Ports		p_{max} [bar]	State
A, B	Working line (pressure port)	400	O
S	Suction port	30	O
M_A, M_B, M_{AB}	Measuring working pressure A/B	400	X
M_S	Measuring suction	30	X
T	Fluid drain	4	X
E₁	Filter, supply	50	X
E₂	Filter, return	50	X
K₁	Flushing port	5	O
K₂, K₃	Fluid filling + air bleeding	4	X
R(L)	Return flow (drain port)	4	O
U	Bearing flushing	7	X
E₃	Boost pressure supply	40	X
M_{E3}	Measuring boost pressure	40	X
K₄	Accumulator port	40	X
M_{K4}	Measuring boost pressure	40	X
M₁	Measurement of stroking chamber pressure	400	X
M₂	Measurement of stroking chamber pressure	400	X

Example A4CSG...EPD...F..4M

Sizes 250 and 355. Additional sizes available on request.

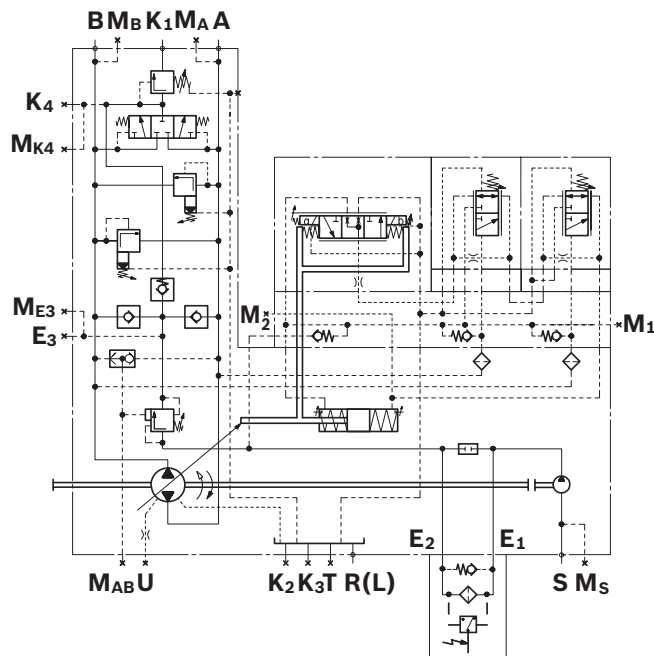

Installation instructions

General

The axial piston unit must be filled with hydraulic fluid and air bled during commissioning and operation. This must also be observed following a longer standstill as the axial piston unit may empty via the hydraulic lines. Especially with the "drive shaft upwards" installation position, bearing flushing is recommended for lubrication of the front bearing and of the shaft seal at port **U**. See page 5.

The leakage in the housing area must be directed to the reservoir via the highest drain port (**T**, **R(L)**, **K₂**, **K₃**). For combination pumps, the leakage must be drained off at each single pump.

If a shared drain line is used for several units, make sure that the respective case pressure in each unit is not exceeded. The shared drain line must be dimensioned to ensure that the maximum permissible case pressure of all connected units is not exceeded in any operating condition, particularly at cold start. If this is not possible, separate drain line must be laid.

To prevent the transmission of structure-borne noise, use elastic elements to decouple all connecting lines from all vibration-capable components (e.g. reservoir, frame parts). Under all operating conditions, the suction lines and the drain lines must flow into the reservoir below the minimum fluid level. The permissible suction height h_s results from the total pressure loss. However, it must not be higher than $h_{s \max} = 800$ mm. The minimum suction pressure at port **S** must not fall below 0.8 bar absolute during operation either.

For external boost pressure supply (version **K..**), please refer to the attachment pump data sheet for details on the minimum suction pressure.

When designing the reservoir, ensure that there is adequate distance between the suction line and the drain line. This minimizes oil turbulence and carries out degassing, which prevents the heated hydraulic fluid from being sucked directly back in again.

Installation position

See the following examples **1** to **8**.

Further installation positions are available upon request. Recommended installation position: **1**.

Notice

- ▶ To achieve an optimum control function, the stroking chambers must be bled via the highest air bleed port **R2** to **R7** depending on the installation position for HS5 and EO.
- ▶ You can expect installation positions **2**, **3**, **6** and **7** to affect the control device. Gravity, dead weight and case pressure can cause minor characteristic shifts and changes in response time.

Key

F	Filling / Air bleeding
R(L)	Filling / Air bleeding
S	Suction port
A, B	Pressure port
T	Drain port
U	Flushing port
K₂, K₃	Flushing port
SB	Baffle (baffle plate)
$h_{t \min}$	Minimum required immersion depth (200 mm)
h_{\min}	Minimum required distance to reservoir bottom (100 mm)
$h_{s \max}$	Maximum permissible suction height (800 mm)
$h_{ES \max}$	Minimum height required to prevent draining of the axial piston unit (25 mm)

Notice

Port **F** is part of the external piping and must be provided on the customer side to make filling and air bleeding easier.

Below-reservoir installation (recommended)

Below-reservoir installation means that the axial piston unit is installed outside of the reservoir below the minimum fluid level.

▼ **Installation position 1**

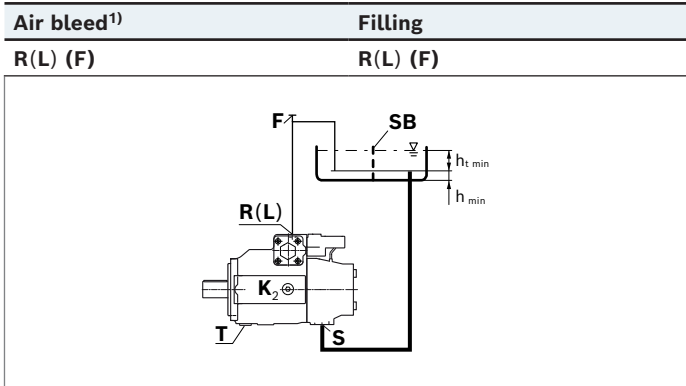

▼ **Installation position 2**

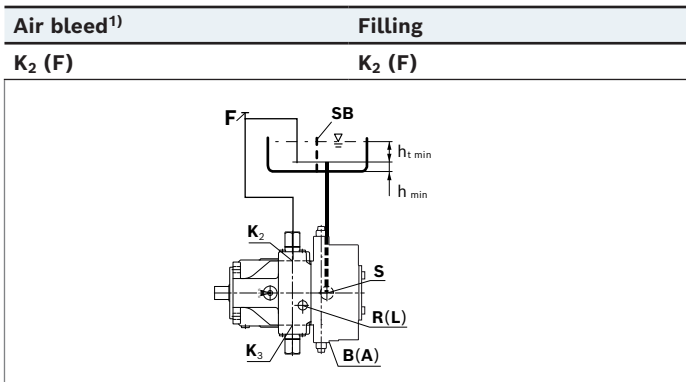

▼ **Installation position 3**

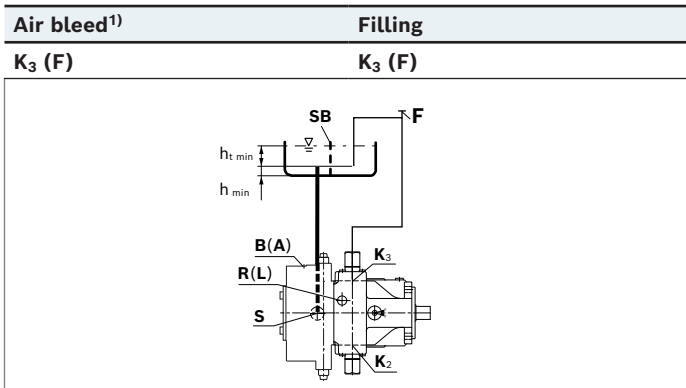

For key, see page 34.

1) To air bleed the stroking chamber, use the highest port on the control (see data sheet of the respective control)

▼ **Installation position 4**

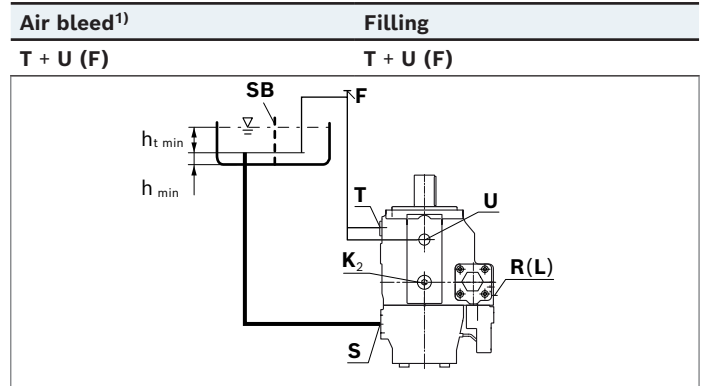

Notice

Bearing flushing at port **U** required.
For information, see page 5

Above-reservoir installation

Above-reservoir installation means that the axial piston unit is installed above the minimum fluid level of the reservoir.

To prevent the axial piston unit from draining, a height difference $h_{ES\ min}$ of at least 25 mm at port **T** is required in position 8.

▼ **Installation position 5**

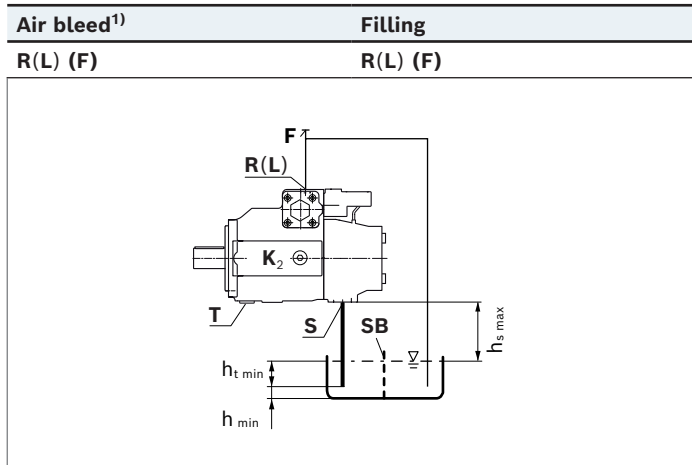

▼ **Installation position 6**

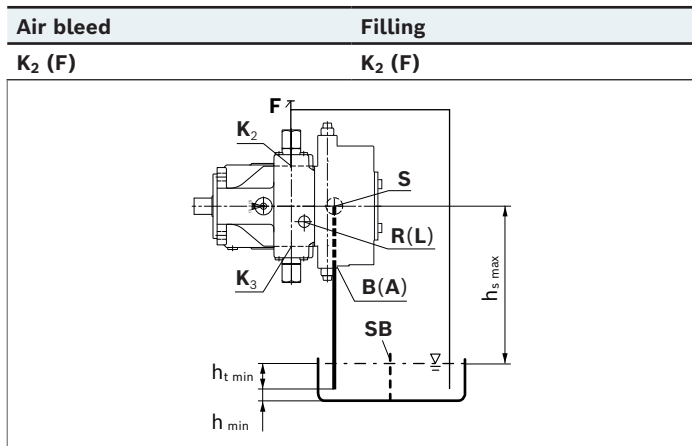

▼ **Installation position 7**

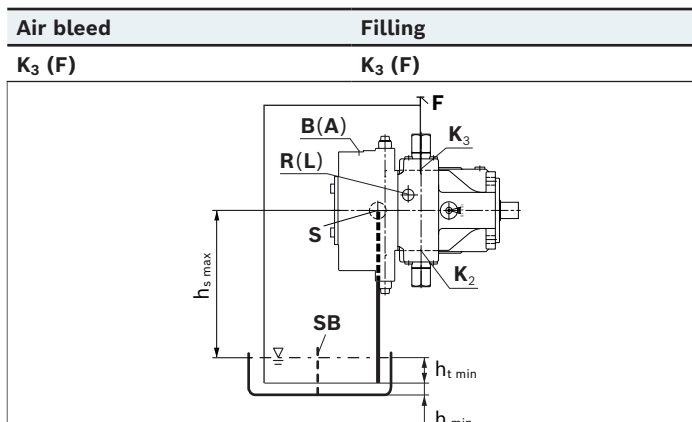

For key, see page 34.

▼ **Installation position 8**

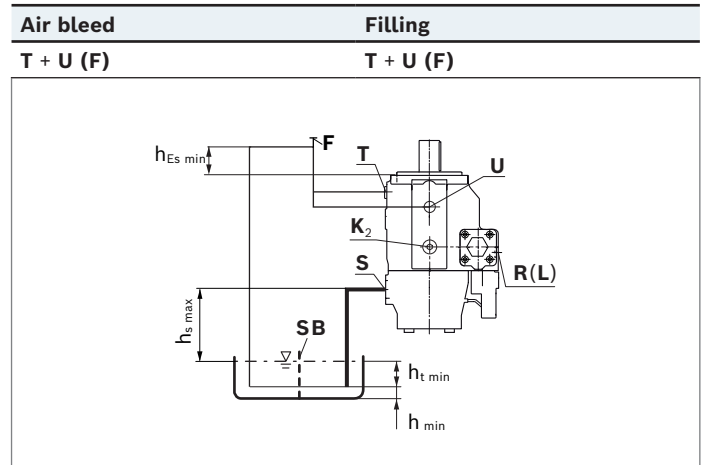

Notice

Bearing flushing at port **U** required.
For information, see page 5

1) To air bleed the stroking chamber, use the highest port on the control (see data sheet of the controller)

Project planning notes

- ▶ The axial piston variable pump A4CSG is intended for use in a closed circuit.
- ▶ The project planning, installation and commissioning of the axial piston unit requires the involvement of skilled personnel.
- ▶ Before using the axial piston unit, please read the corresponding instruction manual completely and thoroughly. If necessary, this can be requested from Bosch Rexroth.
- ▶ Before finalizing your design, please request a binding installation drawing.
- ▶ The specified data and notes contained herein must be observed.
- ▶ Depending on the operating conditions of the axial piston unit (working pressure, fluid temperature), the characteristic curve may shift.
- ▶ The characteristic curve may also shift due to the dither frequency or control electronics.
- ▶ Preservation: Our axial piston units are supplied as standard with preservation protection for a maximum of 12 months. If longer preservation protection is required (maximum 24 months), please specify this in plain text when placing your order. The preservation periods apply under optimal storage conditions, details of which can be found in the data sheet 90312 or the instruction manual.
- ▶ Not all configuration variants of the product are approved for use in a safety function according to ISO 13849. Please consult the proper contact at Bosch Rexroth if you require reliability parameters (e.g., $MTTF_d$) for functional safety.
- ▶ Depending on the type of control used, electromagnetic effects can be produced when using solenoids. Applying a direct voltage signal (DC) to solenoids does not create electromagnetic interference (EMI) nor is the solenoid affected by EMI. Electromagnetic interference (EMI) potential exists when operating and controlling a solenoid with a modulated direct voltage signal (e.g. PWM signal) Appropriate testing and measures should be taken by the machine manufacturer to ensure other components or operators (e.g. with pacemaker) are not affected by this potential.
- ▶ The pressure cut-off (hydraulic or electronic) is not an adequate safeguard against pressure overload. Therefore, a pressure relief valve must be provided in the hydraulic system (integrated into the pump or externally in the system). In this connection, observe the technical limits of the pressure relief valves.
- ▶ For controllers requiring external pilot pressure, sufficient control fluid must be provided to the associated ports to ensure the required pilot pressures for the respective controller function. These controllers are subject to leakage due to their design. An increase in control fluid demand has to be anticipated over the total operating time. The design of the control fluid supply must thus be sufficiently large. If the control fluid is too low, the respective controller function may be impaired and undesired system behavior may result.
- ▶ For drives that are operated for a long period of time with constant rotational speed, the natural frequency of the hydraulic system can be stimulated by the excitation frequency of the pump (rotational speed frequency x 9). This can be prevented with suitably designed hydraulic lines.
- ▶ Please note the details regarding the tightening torques of port threads and other threaded joints in the instruction manual.
- ▶ The ports and fastening threads are designed for the p_{max} permissible pressures of the respective ports, see the connection tables. The machine or system manufacturer must ensure that the connecting elements and lines correspond to the specified application conditions (pressure, flow, hydraulic fluid, temperature) with the necessary safety factors.
- ▶ The service ports and function ports are only intended to accommodate hydraulic lines.

Safety instructions

- ▶ During and shortly after operation, there is a risk of getting burnt on the axial piston unit and especially on the solenoids. Take the appropriate safety measures (e.g. by wearing protective clothing).
- ▶ Moving parts in control equipment (e.g. valve spools) can, under certain circumstances, get stuck in position as a result of contamination (e.g. contaminated hydraulic fluid, abrasion, or residual dirt from components). As a result, the hydraulic fluid flow and the build-up of torque in the axial piston unit can no longer respond correctly to the operator's specifications. Even the use of various filter elements (external or internal flow filtration) will not rule out a fault but merely reduce the risk.

The machine/system manufacturer must test whether remedial measures are needed on the machine for the application concerned in order to bring the driven

consumer into a safe position (e.g. safe stop) and ensure any measures are properly implemented.

- ▶ In certain conditions, moving parts in high-pressure relief valves might get stuck in an undefined position due to contamination (e.g. contaminated hydraulic fluid). This can result in restriction or loss of load-holding functions in lifting winches.

The machine/system manufacturer must check whether additional measures are required on the machine for the relevant application in order to keep the load in a safe position and ensure they are properly implemented.

Related documentation

Product-specific documentation

Document type	Title	Document number
Data sheet	Control devices HM, HS5 and EO series 1x and 30	92076
	Control devices HD	92080
	Control devices EP	92084
	Storage and preservation of axial piston units	90312
Instruction manual	Axial piston variable pump A4CSG series 30 and 33	92105-01-B

Documentation for hydraulic fluids

Document type	Title	Document number
Data sheet	Hydraulic fluids based on mineral oils and related hydrocarbons	90220
	Environmentally acceptable hydraulic fluids	90221
	Rating of hydraulic fluids used in Rexroth hydraulic components (pumps and motors)	90235
	Bosch Rexroth Fluid Rating List for Rexroth hydraulic components (pumps and motors)	90245

Bosch Rexroth AG

An den Kelterwiesen 14
72160 Horb a.N.
Germany
Phone +49 7451 92-0
sales.industry.horb@boschrexroth.de
www.boschrexroth.com

© Bosch Rexroth AG 2003. All rights reserved, also regarding any disposal, exploitation, reproduction, editing, distribution, as well as in the event of applications for industrial property rights. The data specified within only serve to describe the product. As our products are constantly being further developed, no statements concerning a certain condition or suitability for a certain application can be derived from our information. The information given does not release the user from the obligation of own judgment and verification. It must be remembered that our products are subject to a natural process of wear and aging.