

Axial piston fixed motor A2FMT series 70

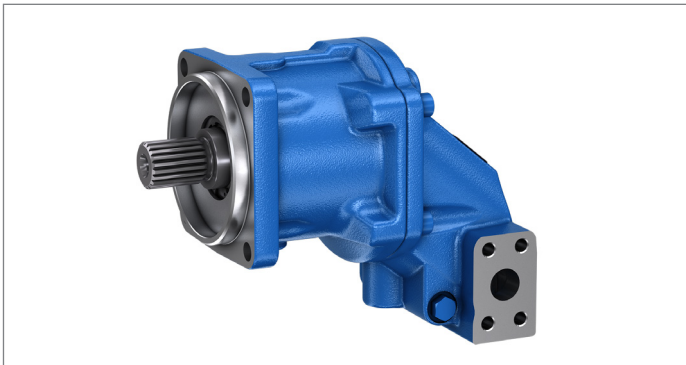

- ▶ Fixed motor for drum drives in concrete mixer trucks
- ▶ Sizes 45 to 107
- ▶ Maximum pressure 420 bar (6100 psi)
- ▶ Closed circuit

Features

- ▶ Fixed motor with an axial tapered piston rotary group in a bent-axis design for closed-circuit hydrostatic drum drives in concrete mixer trucks.
- ▶ The output speed depends on the flow of the pump and the displacement of the motor.
- ▶ The output torque increases with the pressure differential between the high-pressure side and the low-pressure side.
- ▶ High power density
- ▶ Small dimensions
- ▶ High total efficiency
- ▶ Good starting efficiency
- ▶ With integrated flushing valve

Contents

Type code	2
Hydraulic fluids	4
Flow direction	5
Working pressure range	5
Technical data	7
Dimensions, size 45	9
Dimensions, sizes 56, 63 and 80	11
Dimensions, sizes 90 and 107	13
Flushing and boost-pressure valve, integrated	15
Speed sensor	16
Installation instructions	17
Project planning notes	18
Safety instructions	19

Type code

01	02	03	04	05	06	07	08	09	10	11	12	13	14	15	
A2F	M	T		/	70		W	V	C4		02		0	-	

Axial piston unit

01	Bent-axis design, fixed displacement	A2F
----	--------------------------------------	------------

Operating mode

02	Motor, standard version	M
----	-------------------------	----------

Application

03	Concrete mixer trucks	T
----	-----------------------	----------

Size (NG)

04	For the geometric displacement, see technical data on page 7	045	056	063	080	090	107
----	--	------------	------------	------------	------------	------------	------------

Series

05	Series 7, index 0	70
----	-------------------	-----------

Version of port and fastening threads

06	Metric ports based on DIN 3852 with profile sealing ring, metric fastening thread according to DIN 13	N
	Metric ports based on ISO 11926 with O-ring seal, metric fastening threads according to DIN 13	C

Direction of rotation

07	Viewed on drive shaft, bidirectional	W
----	--------------------------------------	----------

Sealing material

08	FKM (fluorocarbon rubber)	V
----	---------------------------	----------

Mounting flange

		045	056	063	080	090	107	
09	SAE J744	127-4	●	●	●	●	●	C4

Drive shaft

		045	056	063	080	090	107	
10	Splined shaft ANSI B92.1a	1 1/4 in 14T 12/24 DP	●	-	-	-	-	S7
		1 3/8 in 21T 16/32 DP	-	●	●	●	●	V8

Working port

		045	056	063	080	090	107	
11	SAE working ports A and B at the side, opposite	●	●	●	●	●	●	02

Valves

		045	056	063	080	090	107		
12	Integrated flushing and boost-pressure valve Flushing flow at: $\Delta p = p_{ND} - p_G = 25$ bar and $v = 10$ mm ² /s	Flushing flow [l/min (gpm)] / Orifice \varnothing [mm (inch)]	2.6 (0.69) / 1.0 (0.04)	○	○	○	○	○	C
		4.0 (1.06) / 1.3 (0.051)	○	○	○	○	○	○	D
		6.0 (1.58) / 1.5 (0.06)	●	●	●	○	○	○	E
		7.4 (1.95) / 1.7 (0.067)	○	○	○	○	○	○	F
		8.5 (2.25) / 1.8 (0.071)	○	○	○	●	●	●	G
		10.0 (2.64) / 2.0 (0.078)	○	○	○	○	○	○	H
		11.4 (3.01) / 2.3 (0.09)	○	○	○	○	○	●	I
12.5 (3.30) / 3 (0.12)	○	○	○	○	○	○	J		

Speed sensor

		045	056	063	080	090	107	
13	Without speed sensor	●	●	●	●	●	●	0
	Prepared for sensor DSA/20 or DST	●	●	●	●	●	●	W
	DSA/20 speed sensor mounted ¹⁾	●	●	●	●	●	●	C
	DST speed sensor mounted ¹⁾	●	●	●	●	●	●	E

● = Available ○ = On request - = Not available

¹⁾ Type codes of the sensors must be specified separately in accordance with data sheet 95131 (DST) or data sheet 95126 (DSA/20).

01	02	03	04		05	06	07	08	09	10	11	12	13	14	15
A2F	M	T		/	70		W	V	C4		02			0	-

Special version

14	Standard version	0
----	------------------	----------

Standard/special version

15	Standard version	0
	Standard version with installation variant, e.g., T ports against standard open or closed	Y
	Special version	S

Notice

- ▶ Note the project planning notes on page 18
- ▶ Please note that not all type code combinations are available although the individual functions are marked as being available.

Hydraulic fluids

The fixed motor A2FMT is designed for operation with HLP mineral oil according to DIN 51524.

Application instructions and requirements for hydraulic fluid selection, behavior during operation as well as disposal and environmental protection should be taken from the following data sheets before the start of project planning:

- ▶ 90220: Hydraulic fluids based on mineral oils and related hydrocarbons
- ▶ 90221: Environmentally acceptable hydraulic fluids

Notice

For operation with HF hydraulic fluids, please contact us.

Selection of hydraulic fluid

Bosch Rexroth evaluates hydraulic fluids on the basis of the Fluid Rating according to the technical data sheet 90235. Hydraulic fluids with positive evaluation in the Fluid Rating are listed in the following data sheet:

- ▶ 90245: Bosch Rexroth Fluid Rating List for Rexroth hydraulic components (pumps and motors)

The hydraulic fluid shall be selected so that the operating viscosity in the operating temperature range is within the optimum range (v_{opt} see selection diagram).

Viscosity and temperature of hydraulic fluids

	Viscosity	Shaft seal	Temperature ³⁾	Remarks
Cold start	$v_{max} \leq 1600 \text{ mm}^2/\text{s}$	NBR ²⁾	$\vartheta_{St} \geq -40 \text{ }^\circ\text{C}$ (-40 °F)	$t \leq 3 \text{ min}$, without load ($p \leq 50 \text{ bar}$ (725 psi)), $n \leq 1000 \text{ rpm}$ Permissible temperature difference between axial piston unit and hydraulic fluid in the system maximum 25 K
		FKM	$\vartheta_{St} \geq -25 \text{ }^\circ\text{C}$ (-13 °F)	
Warm-up phase	$v = 1600 \dots 400 \text{ mm}^2/\text{s}$			$t \leq 15 \text{ min}$, $p \leq 0.7 \times p_{nom}$ and $n \leq 0.5 \times n_{nom}$
Continuous operation	$v = 400 \dots 10 \text{ mm}^2/\text{s}^1)$	NBR ²⁾	$\vartheta \leq +78 \text{ }^\circ\text{C}$ (+172 °F)	Measured at port T
		FKM	$\vartheta \leq +103 \text{ }^\circ\text{C}$ (+217 °F)	
	$v_{opt} = 36 \dots 16 \text{ mm}^2/\text{s}$			Optimal operating viscosity and efficiency range
Short-term operation	$v_{min} = 10 \dots 7 \text{ mm}^2/\text{s}$	NBR ²⁾	$\vartheta \leq +78 \text{ }^\circ\text{C}$ (+172 °F)	$t \leq 3 \text{ min}$, $p \leq 0.3 \times p_{nom}$, measured at port T
		FKM	$\vartheta \leq +103 \text{ }^\circ\text{C}$ (+217 °F)	

Notice: The maximum circuit temperature of +115 °C (+239 °F) must not be exceeded at the working ports **A** and **B** complying with the permissible viscosity.

▼ Selection diagram

Maximum permissible viscosity on cold start

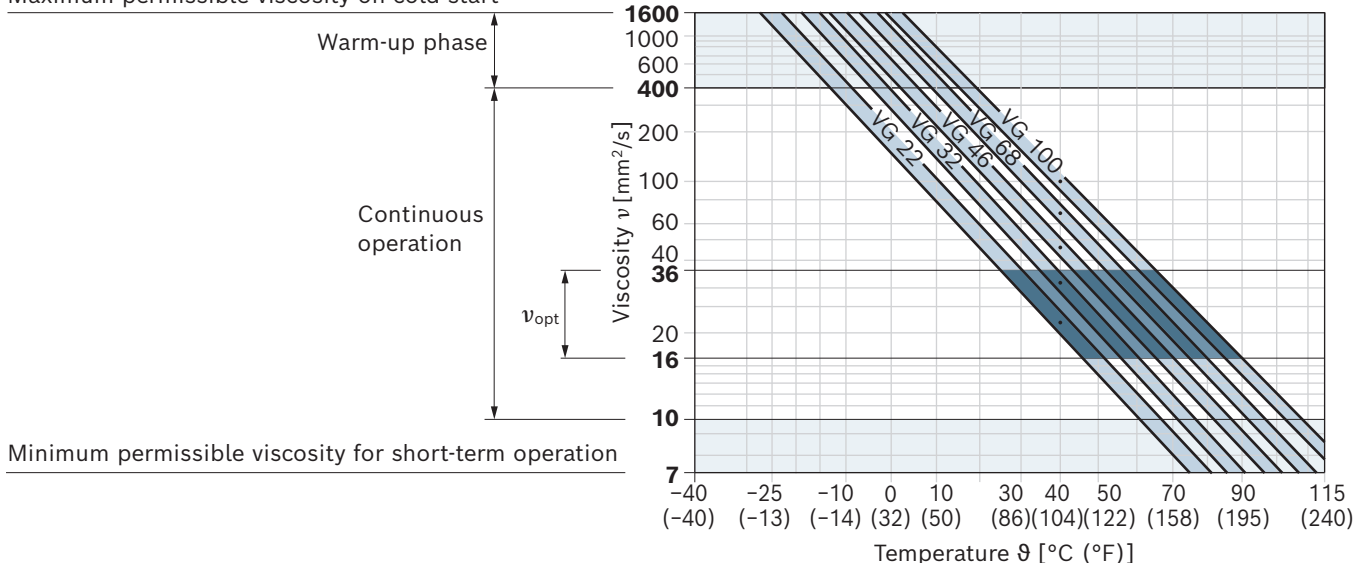

1) This corresponds, for example on the VG 46, to a temperature range of +4 °C (+39 °F) to +85 °C (+185 °F) (see selection diagram)

2) Special version, please contact us

3) If the temperature cannot be adhered to due to extreme operating parameters, please contact us.

Filtration of the hydraulic fluid

Finer filtration improves the cleanliness level of the hydraulic fluid, which increases the service life of the axial piston unit.

A cleanliness level of at least 20/18/15 according to ISO 4406 is to be maintained.

At a hydraulic fluid viscosity of less than 10 mm²/s (e.g., due to high temperatures during short-term operation) at the drain port, a cleanliness level of at least 19/17/14 according to ISO 4406 is required.

For example, the viscosity is 10 mm²/s at:

- ▶ a temperature of 73 °C (163 °F) for HLP 32
- ▶ a temperature of 85 °C (185 °F) for HLP 46

Flow direction

Direction of rotation viewed on drive shaft	
Clockwise	Counter-clockwise
A to B	B to A

Working pressure range

Pressure at working port A or B		Definition
Nominal pressure p_{nom}	280 bar (4100 psi)	The nominal pressure corresponds to the maximum design pressure.
Maximum pressure p_{max}	420 bar (6100 psi)	The maximum pressure corresponds to the maximum working pressure within a single operating period. The sum of single operating periods must not exceed the total operating period.
Single operating period	10 s	
Total operating period	200 h	
Minimum pressure (high-pressure side)	25 bar (365 psi)	Minimum pressure at the high-pressure side (A or B) which is required to prevent damage to the axial piston unit.
Minimum pressure – operation as a pump (inlet)	See diagram (next page)	To prevent damage to the axial piston motor during operation as a pump (change of the high-pressure side with constant direction of rotation, e.g., during brake applications) a minimum pressure has to be ensured at the working port (inlet). The minimum pressure depends on the rotational speed and displacement of the axial piston unit.
Summation pressure p_{Su} (pressure A + pressure B)	700 bar (10150 psi)	The summation pressure is the sum of the pressures at the ports for the working lines (A and B).
Rate of pressure change $R_{A,max}$	16000 bar/s (232060 psi/s)	Maximum permissible pressure build-up and pressure drop rate
Case pressure at port T		
Continuous differential pressure $\Delta p_{T,cont}$	2 bar (30 psi)	Maximum, averaged differential pressure at the shaft seal (case pressure to ambient pressure)
Pressure peaks $p_{T,peak}$	10 bar (145 psi)	$t < 0.1$ s

▼ **Rate of pressure change $R_{A \max}$**

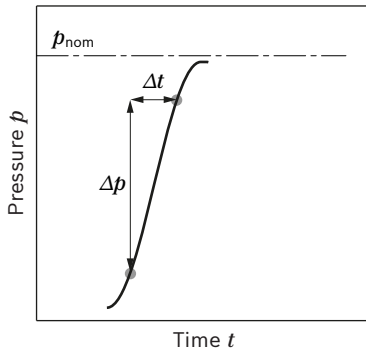

▼ **Minimum pressure – operation as a pump (inlet)**

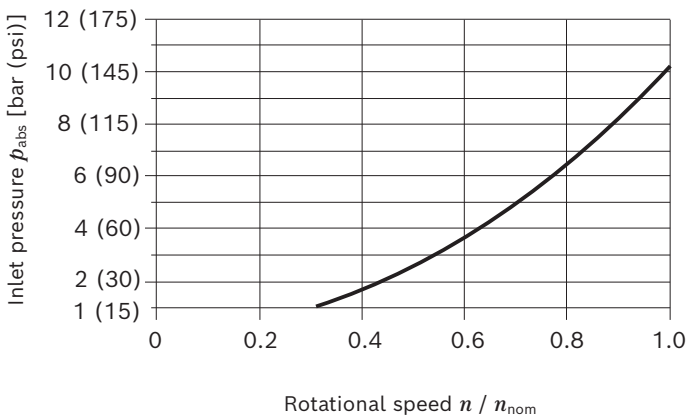

This diagram is only valid for the optimum viscosity range of $\nu_{opt} = 36$ to $16 \text{ mm}^2/\text{s}$.
If the above-mentioned conditions cannot be ensured, please contact us.

▼ **Pressure definition**

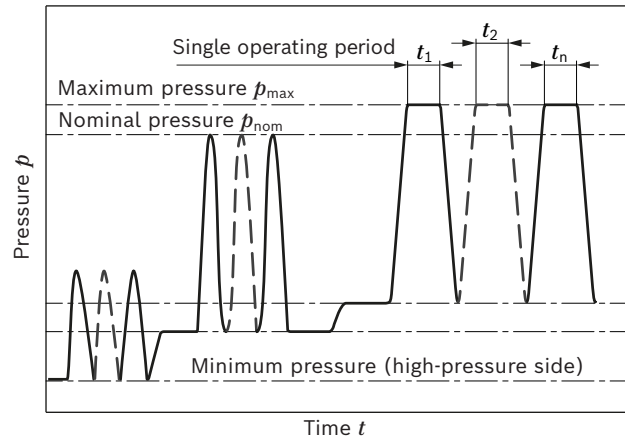

Total operating period = $t_1 + t_2 + \dots + t_n$

Notice

- ▶ Working pressure range applies when using hydraulic fluids based on mineral oils. For values for other hydraulic fluids, please contact us.
- ▶ In addition to the hydraulic fluid and the temperature, the service life of the shaft seal is influenced by the rotational speed of the axial piston unit and the case pressure.
- ▶ The service life of the shaft seal decreases with increasing frequency of pressure peaks and increasing mean differential pressure.
- ▶ The case pressure must be greater than the external pressure (ambient pressure) at the shaft seal.

Technical data

Size	NG		45	56	63	80	90	107	
Displacement geometric, per revolution	V_g	cm ³ (in ³)	44.2 (2.70)	56.6 (3.45)	63.0 (3.84)	81.7 (4.99)	90.5 (5.52)	108.8 (6.64)	
Maximum rotational speed ¹⁾	n_{nom}	rpm	4200	3750	3750	3375	3375	3000	
	$n_{max}^{2)}$	rpm	4650	4125	4125	3700	3700	3300	
Inlet flow	at n_{nom}	$q_{v max}$	l/min (gpm)	186 (49.04)	212 (56.07)	236 (62.41)	276 (72.84)	305 (80.69)	326 (86.23)
Torque ³⁾	at $\Delta p = 280$ bar (4060 psi)	M	Nm (lb-ft)	197 (145)	252 (186)	281 (207)	364 (269)	403 (297)	485 (358)
Rotary stiffness		c_{min}	kNm/rad (klb-ft/rad)	4.84 (3.57)	6.97 (5.14)	8.11 (5.98)	8.47 (6.25)	9.85 (7.26)	10.96 (8.08)
Moment of inertia of the rotary group		J_{TW}	kgm ² (lb-ft ²)	0.0012 (0.028)	0.0034 (0.081)	0.0035 (0.083)	0.0037 (0.088)	0.0058 (0.138)	0.0061 (0.145)
Case volume		V	l (gal)	0.3 (0.08)	0.6 (0.16)	0.6 (0.16)	0.6 (0.16)	0.65 (0.17)	0.65 (0.17)
Weight approx.		m	kg (lbs)	10.7 (23.6)	17 (37.5)	17 (37.5)	17 (37.5)	23 (50.7)	23 (50.7)

Speed range

No limit to minimum speed n_{min} . If uniformity of motion is required, speed n_{min} must not be less than 50 rpm.

Determination of the operating characteristics

Inlet flow	$q_v = \frac{V_g \times n}{1000 \times \eta_v}$ [l/min]	$\left(\frac{V_g \times n}{231 \times \eta_v} \right)$ [gpm]
Rotational speed	$n = \frac{q_v \times 1000 \times \eta_v}{V_g}$ [rpm]	$\left(\frac{q_v \times 231 \times \eta_v}{V_g} \right)$ [rpm]
Torque	$M = \frac{V_g \times \Delta p \times \eta_{hm}}{20 \times \pi}$ [Nm]	$\left(\frac{V_g \times \Delta p \times \eta_{hm}}{24 \times \pi} \right)$ [lb-ft]
Power	$P = \frac{2 \pi \times M \times n}{60000} = \frac{q_v \times \Delta p \times \eta_t}{600}$ [kW]	$\left(\frac{2 \pi \times M \times n}{33000} = \frac{q_v \times \Delta p \times \eta_t}{1714} \right)$ [PS]

Key

V_g	= Displacement per revolution [cm ³ (in ³)]
Δp	= Differential pressure [bar (psi)]
n	= Rotational speed [rpm]
η_v	= Volumetric efficiency
η_{hm}	= Hydraulic-mechanical efficiency
η_t	= Total efficiency ($\eta_t = \eta_v \cdot \eta_{hm}$)

Notice

- ▶ Theoretical values, without efficiency and tolerances; values rounded
- ▶ Operation above the maximum values or below the minimum values may result in a loss of function, a reduced service life or in the destruction of the axial piston unit.
- ▶ Technical data on torsional vibrations available on request.

1) The values apply (subject to the maximum permissible inlet flow):
 – for the optimum viscosity range from $v_{opt} = 36$ to 16 mm²/s
 – with hydraulic fluid based on mineral oils

2) Intermittent maximum speed: Overspeed for unloading and overhauling processes, $t < 5$ s and $\Delta p < 150$ bar (2200 psi)
 3) Torque without radial force, with radial force see page 8

Permissible radial and axial loading on the drive shafts

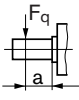
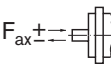
Size	NG		45	56	63	80	90	107	
Drive shaft	Code		S7	V8	V8	V8	V8	V8	
With splined shaft	\varnothing	in	1 1/4	1 3/8	1 3/8	1 3/8	1 3/8	1 3/8	
Maximum radial force ¹⁾ at distance a (from shaft collar)		$F_{q \max}$	kN	5.0	5.8	6.4	8.3	9.2	11.1
			lbf	1124	1304	1439	1866	2068	2495
Maximum torque at $F_{q \max}$	$T_{q \max}$		Nm	197	252	281	364	403	485
			lb-ft	145	186	207	268	297	358
Maximum differential pressure at $F_{q \max}$	$\Delta p_{q \max}$		bar	280	280	280	280	280	280
			psi	4060	4060	4060	4060	4060	4060
Maximum axial force at standstill or depressurized operation		$+ F_{ax \max}$	(lbf) N	0	0	0	0	0	
		$- F_{ax \max}$	N	500	800	800	800	1000	1000
			lbf	112.4	179.8	179.8	179.8	224.8	224.8
Permissible axial force per bar working pressure	$+ F_{ax \text{ perm}}/\text{bar}$		N/bar	5.2	8.7	8.7	8.7	10.6	10.6
			lbf/psi	0.08	0.13	0.13	0.13	0.16	0.16

Effect of radial force F_q on bearing service life

By selecting a suitable force-transfer direction of F_q , the stress on the bearings caused by the internal transmission forces can be reduced, thus achieving the optimum service life of the bearings. Recommended position of mating gear is dependent on the direction of rotation. Examples:

▼ **Gear output drive**

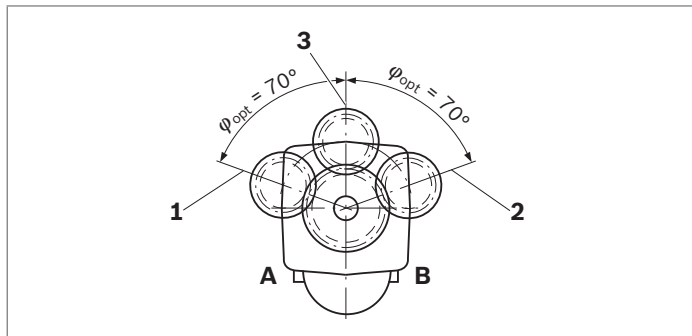

- 1 "Counter-clockwise" rotation Pressure at port **B**
- 2 "Clockwise" rotation, pressure at port **A**
- 3 "Bidirectional" rotation

Notice

- ▶ The values given are maximum values and do not apply to continuous operation.
- ▶ The permissible axial force in direction $-F_{ax}$ is to be avoided as the service life of the bearing is reduced.
- ▶ Special requirements apply in the case of belt output drives. Please contact us.

1) With intermittent operation

Dimensions, size 45

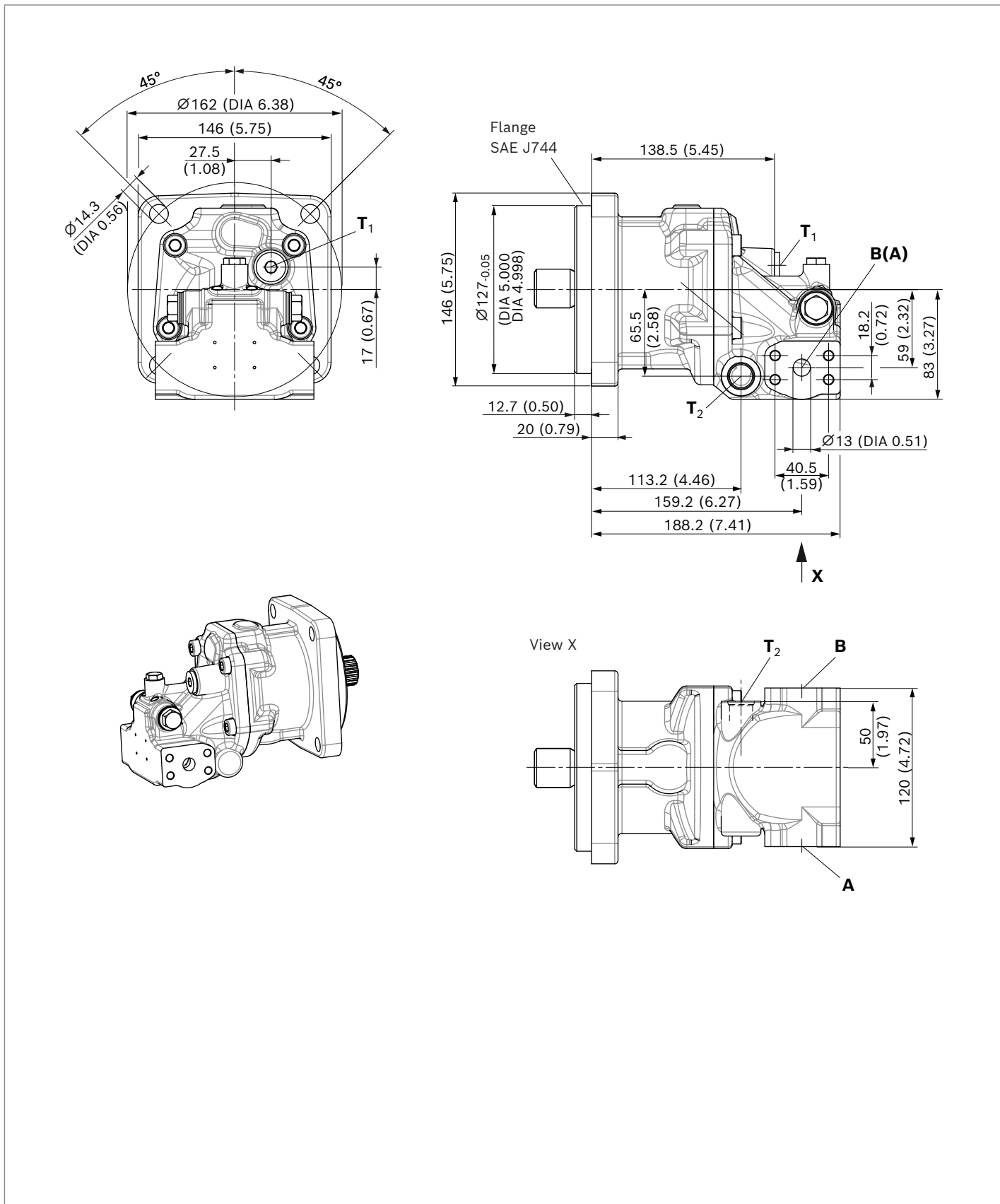

▼ **Splined shaft SAE J744, sizes 45**

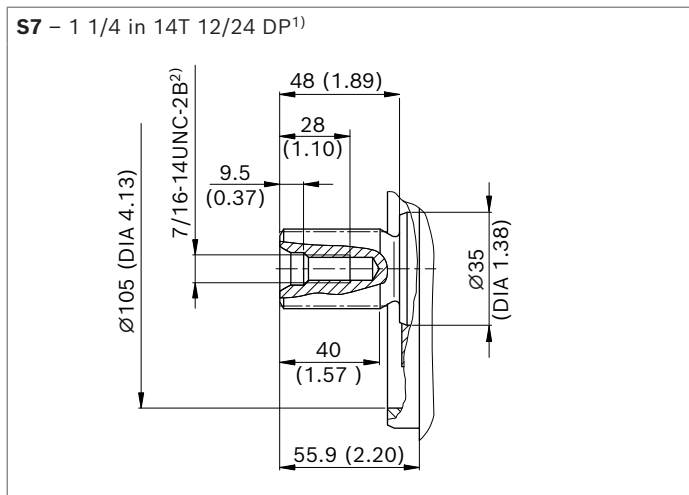

Metric version (code "N")

Ports		Standard	Size	p_{max} [bar (psi)] ³⁾	State ⁶⁾
A, B	Working port	SAE J518	1/2 in	420 (6100)	O
	Fastening thread	DIN 13	M8 × 1.25; 16 (0.63) deep		
T₁	Drain port	DIN 3852 ⁵⁾	M16 × 1.5; 12 (0.47) deep	3 (45)	X ⁴⁾
T₂	Drain port	DIN 3852 ⁵⁾	M16 × 1.5; 12 (0.47) deep	3 (45)	O ⁴⁾

ANSI version (code "C")

Ports		Standard	Size	p_{max} [bar (psi)] ³⁾	State ⁶⁾
A, B	Working port	SAE J518	1/2 in	420 (6100)	O
	Fastening thread	DIN 13	M8 × 1.25; 16 (0.63) deep		
T₁	Drain port	ISO 11926 ⁵⁾	3/4-16 UNF-2B; 15 (0.59) deep	3 (45)	X ⁴⁾
T₂	Drain port	ISO 11926 ⁵⁾	3/4-16 UNF-2B; 15 (0.59) deep	3 (45)	O ⁴⁾

1) Involute spline according to ANSI B92.1a, 30° pressure angle, flat root, side fit (edge-centered), tolerance class 5
2) Thread according to ASME B1.1
3) Depending on the application, momentary pressure peaks can occur. Keep this in mind when selecting measuring devices and fittings.

4) Depending on installation position, T₁ or T₂ must be connected (see also installation instructions on page 17).
5) The countersink may be deeper than specified in the standard.
6) O = Must be connected (plugged on delivery)
X = Plugged (in normal operation)

Dimensions, sizes 56, 63 and 80

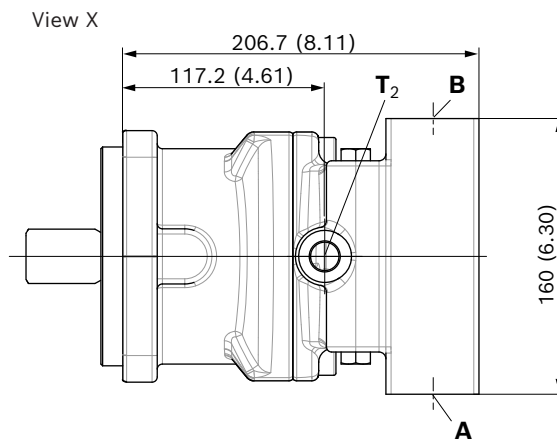
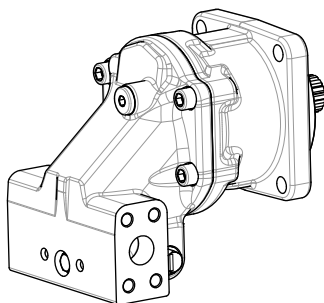
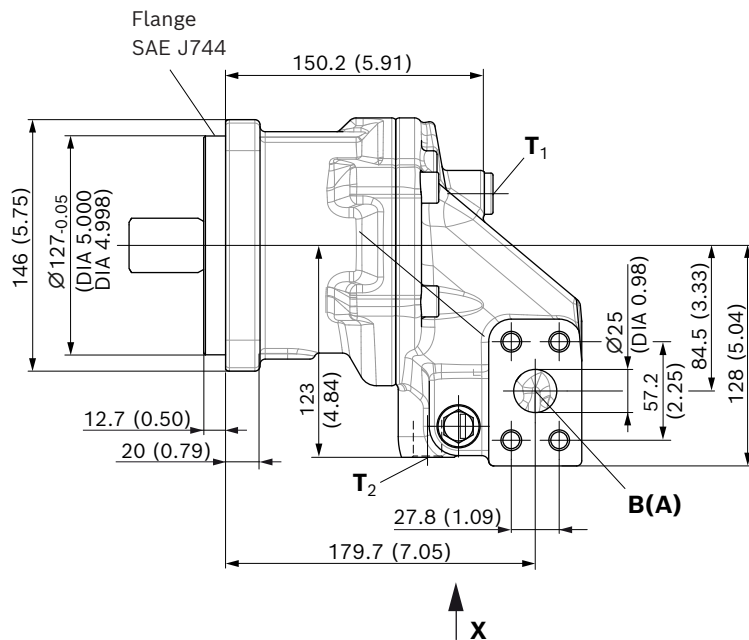
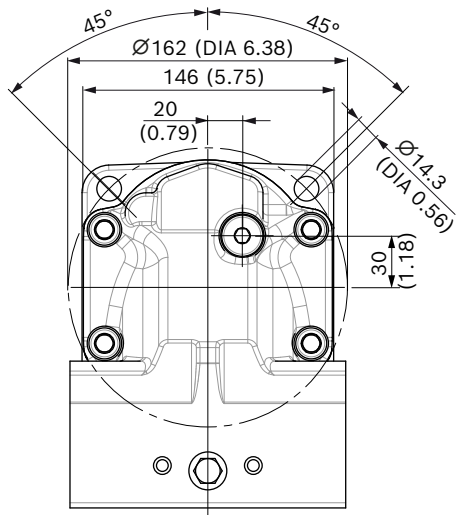

▼ **Splined shaft SAE J744, size 56, 63 and 80**

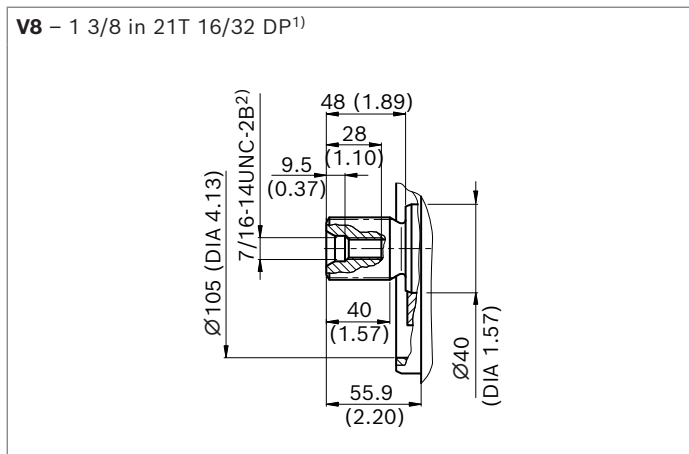

Metric version (code "N")

Ports		Standard	Size	p_{\max} [bar (psi)] ³⁾	State ⁶⁾
A, B	Working port	SAE J518	1 in	420 (6100)	O
	Fastening thread	DIN 13	M12 × 1.75; 17 (0.67) deep		
T₁	Drain port	DIN 3852 ⁵⁾	M18 × 1.5; 12 (0.47) deep	3 (45)	X ⁴⁾
T₂	Drain port	DIN 3852 ⁵⁾	M18 × 1.5; 12 (0.47) deep	3 (45)	O ⁴⁾

ANSI version (code "C")

Ports		Standard	Size	p_{\max} [bar (psi)] ³⁾	State ⁶⁾
A, B	Working port	SAE J518	1 in	420 (6100)	O
	Fastening thread	DIN 13	M12 × 1.75; 17 (0.67) deep		
T₁	Drain port	ISO 11926 ⁵⁾	3/4-16UNF-2B; 15 (0.59) deep	3 (45)	X ⁴⁾
T₂	Drain port	ISO 11926 ⁵⁾	3/4-16UNF-2B; 15 (0.59) deep	3 (45)	O ⁴⁾

1) Involute spline according to ANSI B92.1a, 30° pressure angle, flat root, side fit (edge-centered), tolerance class 5
2) Thread according to ASME B1.1
3) Depending on the application, momentary pressure peaks can occur. Keep this in mind when selecting measuring devices and fittings.

4) Depending on the installation position, T₁ or T₂ must be connected (see also the installation instructions on page 17).
5) The countersink may be deeper than specified in the standard.
6) O = Must be connected (plugged on delivery)
X = Plugged (in normal operation)

Dimensions, sizes 90 and 107

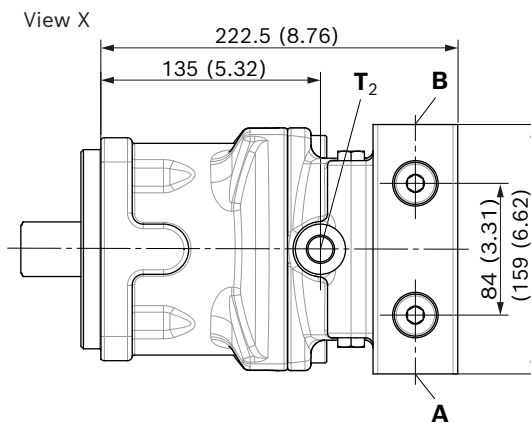
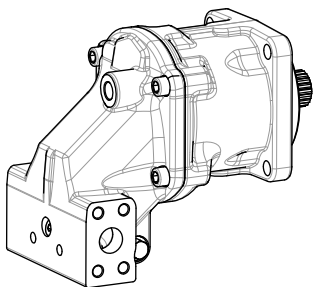
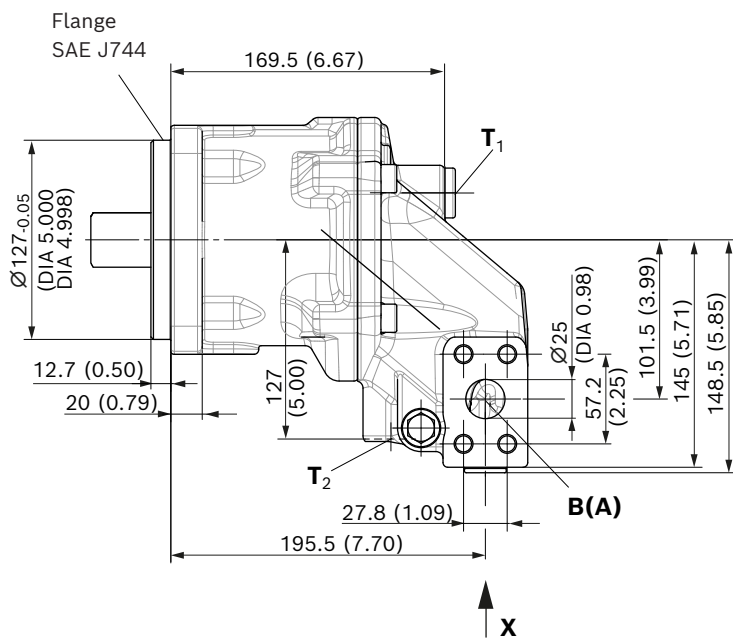
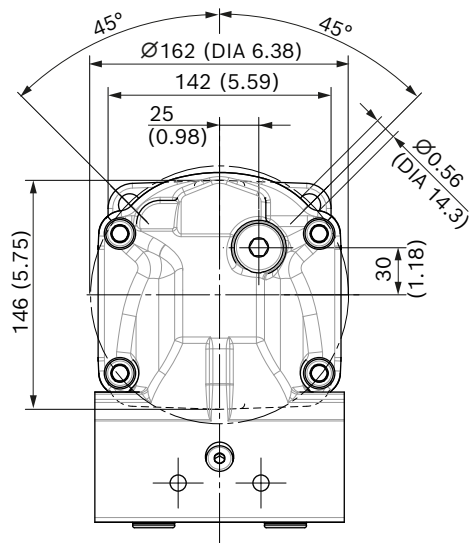

▼ **Splined shaft SAE J744, sizes 90 and 107**

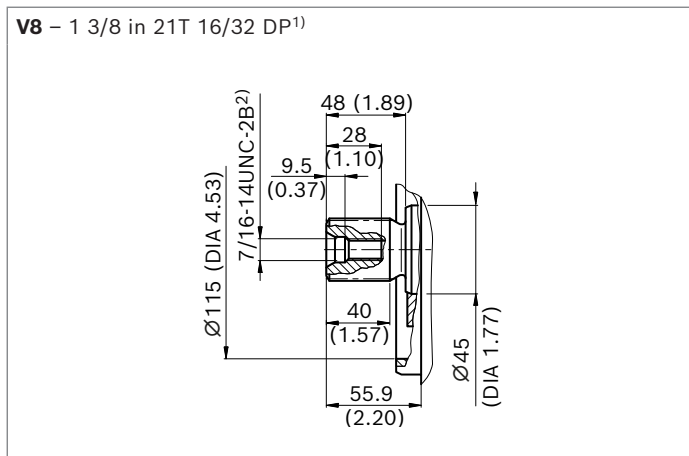

Metric version (code "N")

Ports		Standard	Size	p_{\max} [bar (psi)] ³⁾	State ⁶⁾
A, B	Working port	SAE J518	1 in	420 (6100)	O
	Fastening thread	DIN 13	M12 × 1.75; 17 (0.67) deep		
T₁	Drain port	DIN 3852 ⁵⁾	M18 × 1.5; 12 (0.47) deep	3 (45)	X ⁴⁾
T₂	Drain port	DIN 3852 ⁵⁾	M18 × 1.5; 12 (0.47) deep	3 (45)	O ⁴⁾

ANSI version (code "C")

Ports		Standard	Size	p_{\max} [bar (psi)] ³⁾	State ⁶⁾
A, B	Working port	SAE J518	1 in	420 (6100)	O
	Fastening thread	DIN 13	M12 × 1.75; 17 (0.67) deep		
T₁	Drain port	ISO 11926 ⁵⁾	7/8-14UNF-2B; 17 (0.67) deep	3 (45)	X ⁴⁾
T₂	Drain port	ISO 11926 ⁵⁾	7/8-14UNF-2B; 17 (0.67) deep	3 (45)	O ⁴⁾

1) ANSI B92.1a, 30° pressure angle, flat root, side fit (edge-centered), tolerance class 5
2) Thread according to ASME B1.1
3) Depending on the application, momentary pressure peaks can occur. Keep this in mind when selecting measuring devices and fittings.

4) Depending on the installation position, T₁ or T₂ must be connected (see also the installation instructions on page 17).
5) The countersink may be deeper than specified in the standard.
6) O = Must be connected (plugged on delivery)
X = Plugged (in normal operation)

Flushing and boost-pressure valve, integrated

The flushing and boost-pressure valve is used to remove heat from the hydraulic circuit.

In a closed circuit, it is used for flushing the housing and safeguarding the minimum boost pressure.

Hydraulic fluid is directed from the respective low-pressure side into the motor housing. This is then fed into the reservoir, together with the leakage. In the closed circuit, the removed hydraulic fluid must be replaced by cooled hydraulic fluid supplied by the boost pump.

▼ Circuit diagram

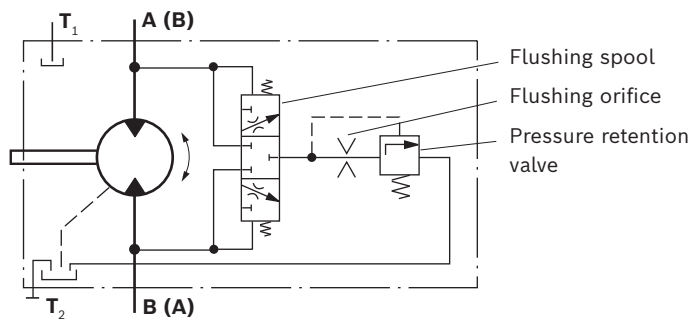

Cracking pressure pressure retention valve

(observe when setting the primary valve)

- Nominal sizes 45 to 107,
fixed setting 16 bar (230 psi)

Switching pressure of flushing spool

- Nominal sizes 45 to 107
 $\Delta p = 8 \pm 1$ bar (115 \pm 15 psi)

Flushing flow

Orifices can be used to adjust the flushing flows as required. The following parameters are based on:

$\Delta p_{ND} = p_{ND} - p_G = 25$ bar (365 psi) and $v = 10$ mm²/s
 (p_{ND} = low pressure, p_G = case pressure)

Size	Code	Orifices DIA [Ø mm (inch)]	Flushing flow q_v [l/min (gpm)]
45, 56, 63, 80, 90, 107	C	1.0 (0.04)	2.6 (0.69)
	D	1.3 (0.051)	4 (1.06)
	E	1.5 (0.06)	6 (1.58)
	F	1.7 (0.067)	7.4 (1.95)
	G	1.8 (0.071)	8.5 (2.25)
	H	2.0 (0.078)	10 (2.64)
	I	2.3 (0.09)	11.4 (3.01)
	J	3 (0.12)	12.5 (3.30)

Speed sensor

The motor speed can be recorded by the mounted DST or DSA speed sensor. The proportional frequency signal required is generated by splines at the rotary group. In addition to the rotational speed, the DST or DSA sensor detects the direction of rotation of the motor and the temperature at the installation location.

The type code, technical data, dimensions and details of the connector, as well as safety instructions about the sensor, can be found in the relevant data sheet DST (95131) or DSA (95126).

The sensor is mounted on the port provided for this purpose with a mounting bolt. On deliveries without sensor, the port is plugged with a pressure-resistant cover. We recommend ordering the A2F fixed motor complete with mounted sensor.

The following versions are available:

- ▶ with mounted speed sensor DSA/20: Code C
- ▶ with mounted speed sensor DST: Code E
- ▶ for speed sensor DST or DSA/20 (delivery without sensor): Code W

Size	45	56, 63, 80	90, 107
Number of teeth	38	47	53
Dimensions	A	108 (4.25)	120.6 (4.75)
	B	44.5 (1.75)	54.6 (2.15)
	C	2 (0.078)	2 (0.078)

Dimensions

▼ A2FMT with mounted speed sensor DST (code E)

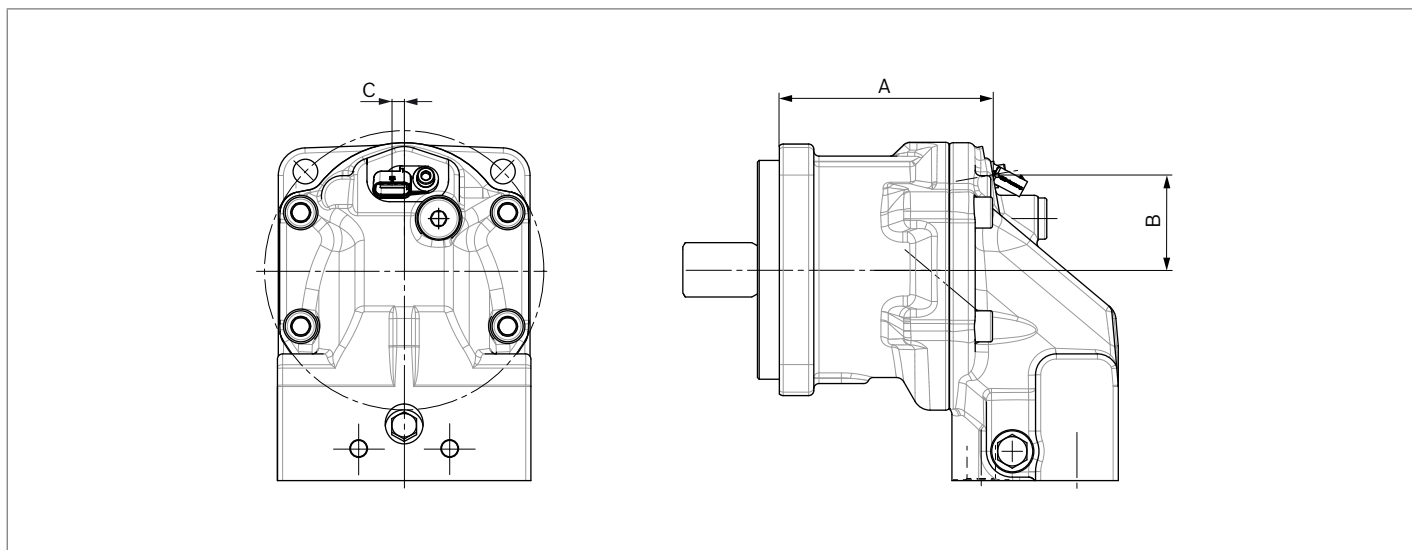

Installation instructions

General

The axial piston unit must be filled with hydraulic fluid and air bled during commissioning and operation. This must also be observed following a longer standstill as the axial piston unit may empty via the hydraulic line. The leakage in the housing area must be directed to the reservoir via the highest drain port (**T₁**, **T₂**).

If a shared drain line is used for several units, make sure that the respective case pressure in each unit is not exceeded. The shared drain line must be dimensioned to ensure that the maximum permissible case pressure of all connected units is not exceeded in any operating conditions, particularly at cold start. If this is not possible, separate drain lines must be laid, if necessary.

To prevent the transmission of structure-borne noise, use elastic elements to decouple all connecting lines from all vibration-capable components (e.g., reservoir, frame parts).

Under all operating conditions, the drain line must flow into the reservoir below the minimum fluid level.

Key	
F	Filling/air bleeding
T₁, T₂	Drain port
$h_{t \min}$	Minimum required immersion depth (200 mm (7.87 inch))
h_{\min}	Minimum required distance to reservoir bottom (100 mm (3.94 inch))

Notice

Port **F** is part of the external piping and must be provided on the customer side to simplify the filling and air bleeding.

Installation position

See the following examples **1** to **4**.

Further installation positions are available upon request.

Recommended installation position: **1** and **2**

Below-reservoir installation (standard)

Below-reservoir installation means that the axial piston unit is installed outside of the reservoir below the minimum fluid level.

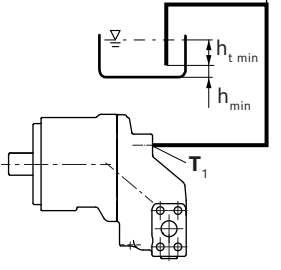
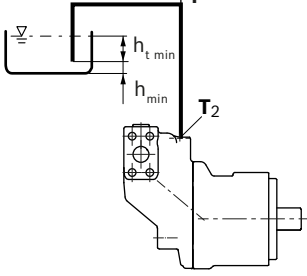
Installation position	Air bleed	Filling
1	–	T₁ (F)
	–	T₂ (F)
2	–	T₂ (F)
		

Above-reservoir installation

Above-reservoir installation means that the axial piston unit is installed above the minimum fluid level of the reservoir.

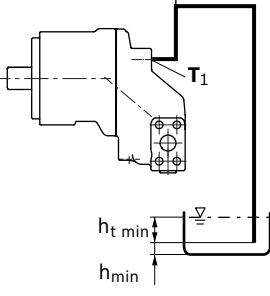
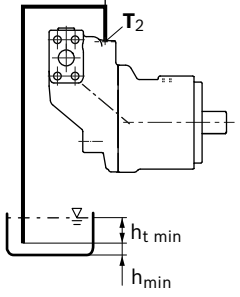
Installation position	Air bleed	Filling
3	F	T₁ (F)
		
4	F	T₂ (F)
		

Project planning notes

- ▶ The A2FMT motor is intended to be used as a drum drive in concrete mixer trucks in closed circuits.
- ▶ The motor has been specifically designed and constructed for the duty cycle in this particular application. The performance data given is based on this duty cycle.
- ▶ The project planning, installation and commissioning of the axial piston unit requires the involvement of skilled personnel.
- ▶ Before using the axial piston unit, please read the corresponding instruction manual completely and thoroughly. If necessary, this can be requested from Bosch Rexroth.
- ▶ Before finalizing your design, please request a binding installation drawing.
- ▶ The specified data and notes contained herein must be observed.
- ▶ Preservation: Our axial piston units are supplied as standard with preservation protection for a maximum of 12 months. If longer preservation protection is required (maximum 24 months), please specify this in plain text when placing your order. The preservation periods apply for optimal storage conditions, which can be found in data sheet 90312 or in the instruction manual.
- ▶ Not all versions of the product are approved for use in safety functions according to ISO 13849. Please consult the responsible contact person at Bosch Rexroth if you require reliability parameters (e.g., MTTFD) for functional safety.
- ▶ Be sure to add a pressure relief valve to the hydraulic system.
- ▶ Please note that a hydraulic system is an oscillating system. This can lead, for example, to the excitation of the natural frequency within the hydraulic system during operation at constant rotational speed over a long period of time. The frequency of the motor to be observed is 7 times the rotational speed frequency. This can be prevented, for example, with suitably designed hydraulic lines.
- ▶ Please note the details regarding the tightening torques of port threads and other threaded joints in the instruction manual.
- ▶ The ports and fastening threads are designed for the p_{\max} permissible pressures of the respective ports, see the connection tables. The machine or system manufacturer must ensure that the connecting elements and lines correspond to the specified application conditions (pressure, flow, hydraulic fluid, temperature) with the necessary safety factors.
- ▶ The service ports and function ports are only intended to accommodate hydraulic lines.
- ▶ Please note that the series connection of motors and the operation under summation pressure affect the efficiency of the units.

Safety instructions

- ▶ During and shortly after operation, there is a risk of getting burnt on the axial piston unit. Take the appropriate safety measures (e.g. by wearing protective clothing).
- ▶ Moving parts in control equipment (e.g. valve spools) can, under certain circumstances, get stuck in position as a result of contamination (e.g. contaminated hydraulic fluid, abrasion, or residual dirt from components). As a result, the hydraulic fluid flow and the build-up of torque in the axial piston unit can no longer respond correctly to the operator's specifications. Even the use of various filter elements (external or internal flow filtration) will not rule out a fault but merely reduce the risk. The machine/system manufacturer must test whether remedial measures are needed on the machine for the application concerned in order to bring the driven consumer into a safe position (e.g., safe stop) and ensure any measures are properly implemented.
- ▶ Moving parts in high-pressure relief valves may in certain circumstances become stuck in an undefined position due to contamination (e.g. impure hydraulic fluid). This can result in restriction or loss of load-holding functions in lifting winches. The machine/system manufacturer must check whether additional measures are required on the machine for the relevant application in order to keep the load in a safe position and ensure they are properly implemented.

Bosch Rexroth AG

Glockeraustrasse 2
89275 Elchingen
Germany
Phone +49 7308 82-0
info.ma@boschrexroth.de
www.boschrexroth.com

© Bosch Rexroth AG 2016. All rights reserved, also regarding any disposal, exploitation, reproduction, editing, distribution, as well as in the event of applications for industrial property rights. The data specified within only serves to describe the product. No statements concerning a certain condition or suitability for a certain application can be derived from our information. The information given does not release the user from the obligation of own judgment and verification. It must be remembered that our products are subject to a natural process of wear and aging.