

Axial piston fixed motor

A2FM series 70

Compact design and high performance

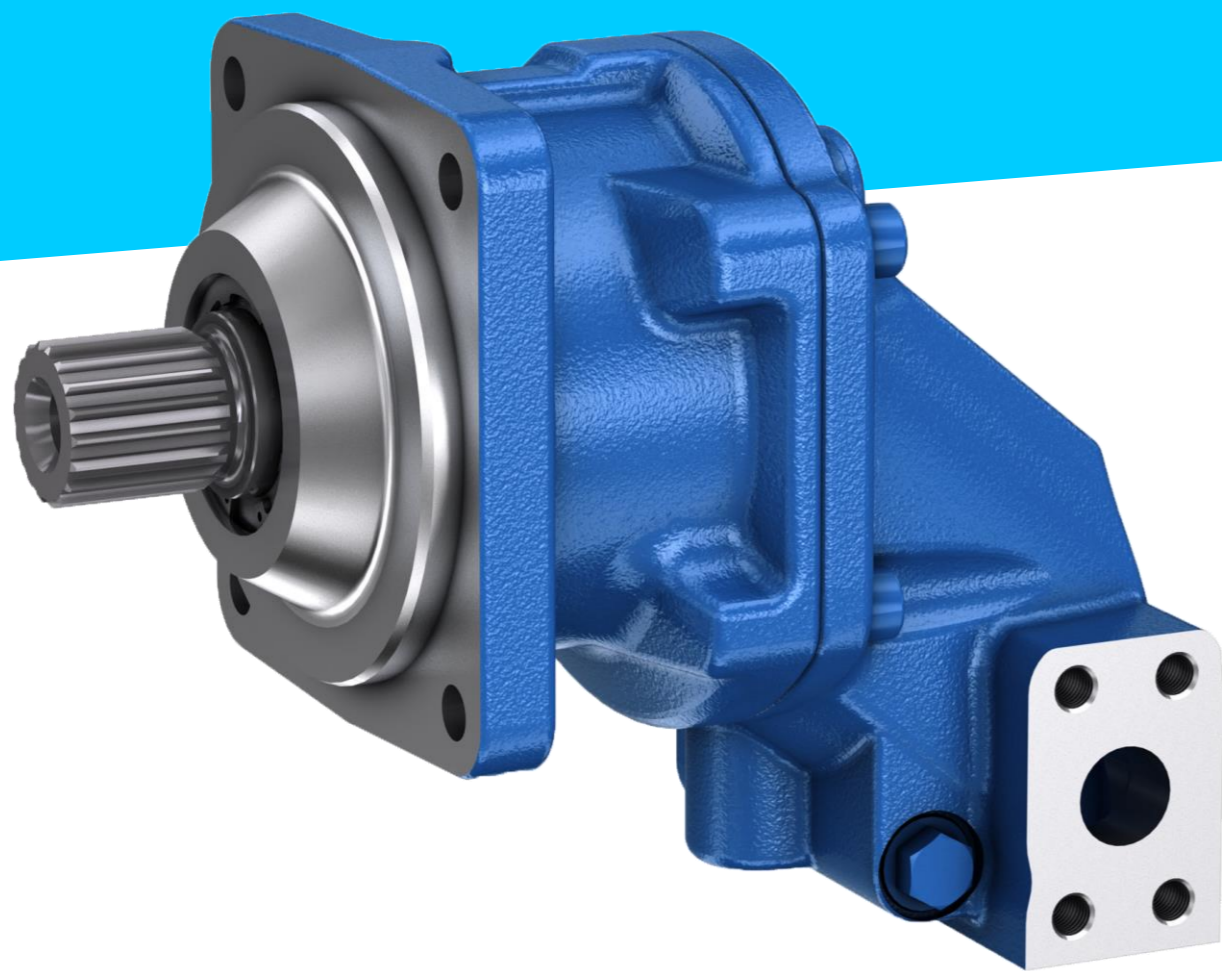

Ambitious emission regulations require new engine generations to be equipped with modern exhaust gas after-treatment systems. The fitment space necessary for these engines is higher than for previous generations. Moreover, these combustion engines show a different performance characteristic. As a result, hydraulic systems have less space available, and its components have to be more efficient in order to maintain today's productivity of working machinery. The Rexroth A2FM axial piston fixed motor series 70 offers answers: a compact design, high power density, a range of pressure levels and a variety of options.

CUSTOMER BENEFITS

- Compact design with built-in valves
- Increased power density compared to series 61
- 3 pressure ranges to fit to different customer requirements and applications
- High overall and starting efficiency
- Robust 40° bent-axis technology

FUNCTION AND BENEFITS

Compact design and higher power density

The compact design of the Rexroth A2FM series 70 offers a higher power density than the series 61. The compact design is realized by several design measures such as an optimized rotary group, improved positioning of the port plate and the integration of flushing valves. For example, the A2FM series 70 with 90 cm³ is up to 26% shorter than the comparable product of the series 61 (with sidewise ports and external flushing valve).

High efficiency and high-speed capability

Bosch Rexroth has long-standing experience in the development of reliable and robust 40° bent-axis technology. Rexroth A2FM series 70 continues the success story of the A2FM series 61 and provides best in class overall and starting efficiency as well as high speed capability.

Different pressure levels

Rexroth A2FM is designed for use in a variety of applications such as concrete mixers, combine harvesters, mobile cranes, drilling equipment and rolling mills. These applications require different pressure levels.

APPLICATIONS

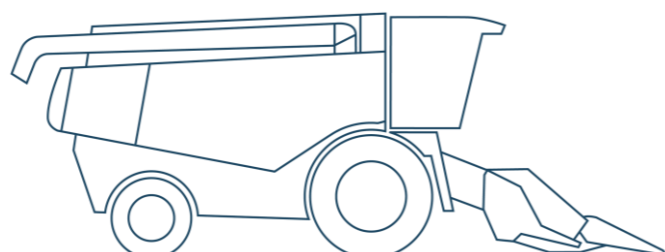
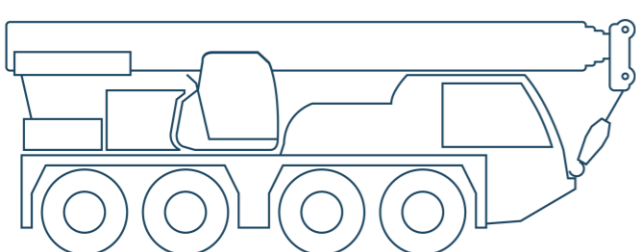
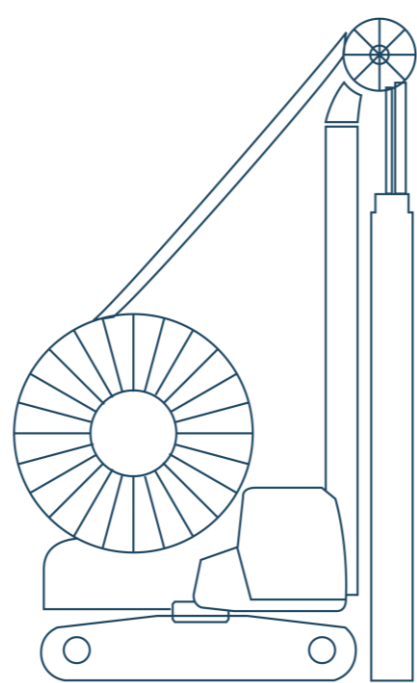
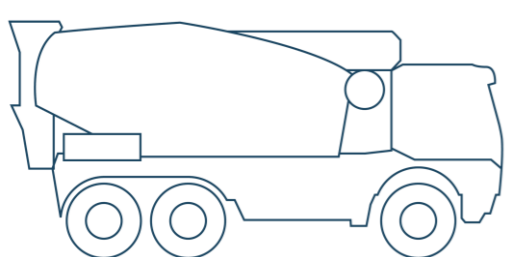

A2FM series 70 axial piston fixed motor

Compact design and high performance

TECHNICAL DATA

Axial piston fixed motor A2FM series 70

Pressure level: 300/350 bar

Sizes:¹⁾ 28 cm³, 32 cm³, 37 cm³, 45 cm³,
56 cm³, 63 cm³, 80 cm³, 90 cm³,
107 cm³

Speed max: 4725 rpm ... 3000 rpm

Pressure level: 400/450 bar

Sizes:¹⁾ 23 cm³, 28 cm³, 32 cm³, 45 cm³,
56 cm³, 63 cm³, 80 cm³, 90 cm³,
107 cm³, 125 cm³, 160 cm³,
180 cm³

Speed max:²⁾ 6300 rpm ... 3600 rpm

Pressure level: 450/500 bar

Sizes:¹⁾ 45 cm³, 56 cm³, 63 cm³, 80 cm³,
90 cm³, 107 cm³, 125 cm³

Speed max:²⁾ 5000 rpm ... 4000 rpm

Weight:²⁾ approx. 10,7 kg ... approx. 23 kg

Hydraulic ports: available with metric or inch threads

Data sheet: 91071

¹⁾ Other sizes in preparation

²⁾ Depends on size

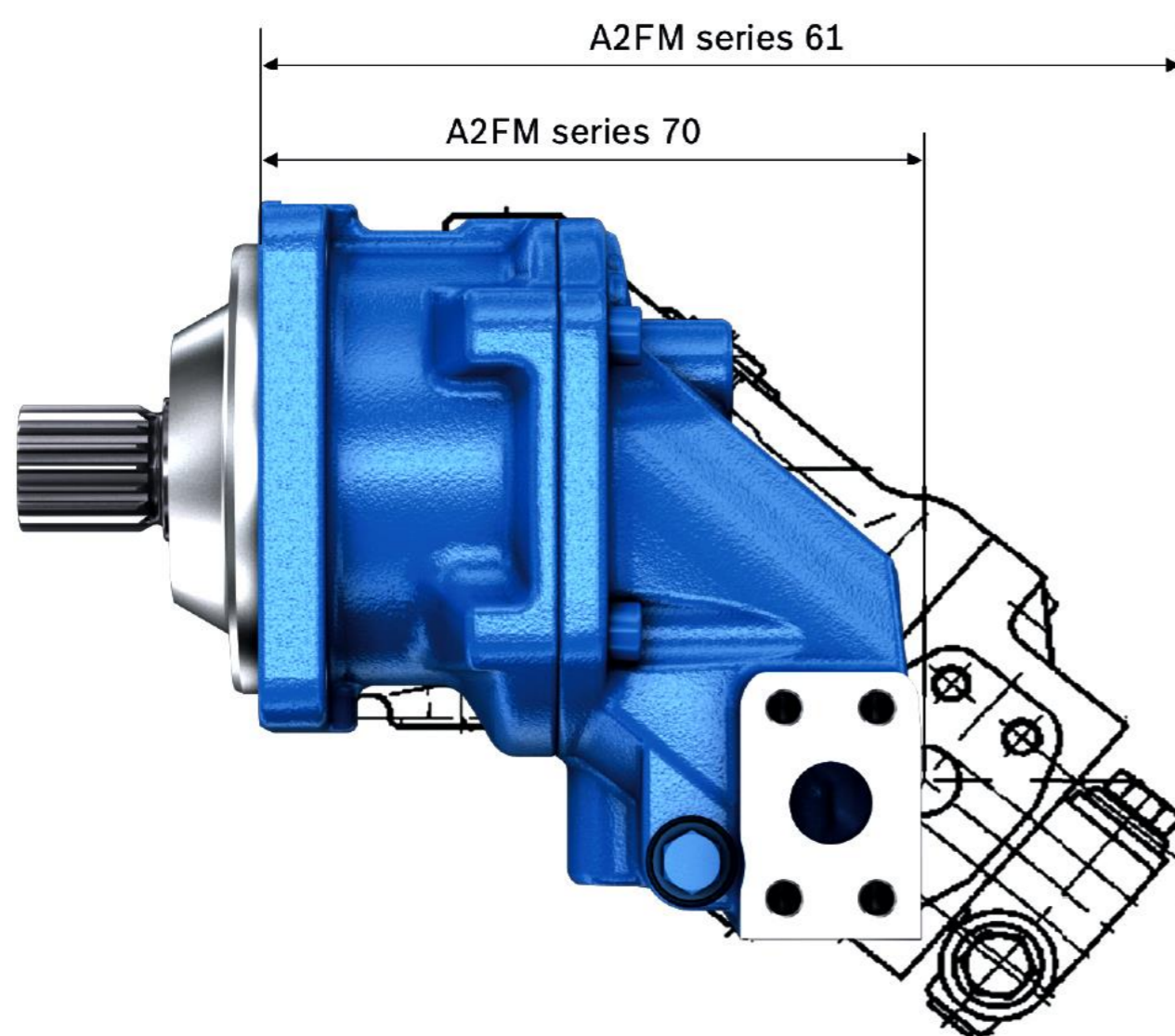

The A2FM series 70 is significantly smaller than the current series 61.

The Rexroth A2FM series 70 covers three pressure levels, that means two additional levels compared to series 61:

- Pressure level with 300 / 350 bar provides high efficiency and robustness for cost-sensitive applications with lower pressure demands, such as winch drives, concrete mixers and fan drives.
- Pressure level with 400 / 450 bar stands for high performance and reliability which is suitable for many applications such as vibration drive for road rollers or drive of rolling mills in industrial applications.
- Pressure level with 450 / 500 bar for highest demands of modern working machines such as combine harvesters. Increased efficiency of hydraulic components which are also used in travel drives is one of the demands. In combination with the Rexroth axial piston variable pump A4VG Series 40, an efficient travel drive can be realized, for example in snow groomers and combine harvesters.

Wide variety and options

Due to the large range of possible applications and the resulting differing requirements, the Rexroth A2FM is modular in its design and offers a variety of options:

- Three different sizes
- Several flanges for plug-in version and mounted version
- Service ports in different directions and versions
- Variety of shaft options
- Wide range of valves and sensors

Bosch Rexroth AG
Glockeraustraße 2
89275 Elchingen, Germany
Phone +49 7308 82-0
Info.ma@boschrexroth.de
www.boschrexroth.com

© Bosch Rexroth AG 2023. All rights reserved, also regarding any disposal, exploitation, reproduction, editing, distribution, as well as in the event of applications for industrial property rights.

The data specified within only serves to describe the product. No statements concerning a certain condition or suitability for a certain application can be derived from our information. The information given does not release the user from the obligation of own judgment and verification. It must be remembered that our products are subject to a natural process of wear and aging.