

# Axial piston variable double pump A28VO

Compact design and high efficiency

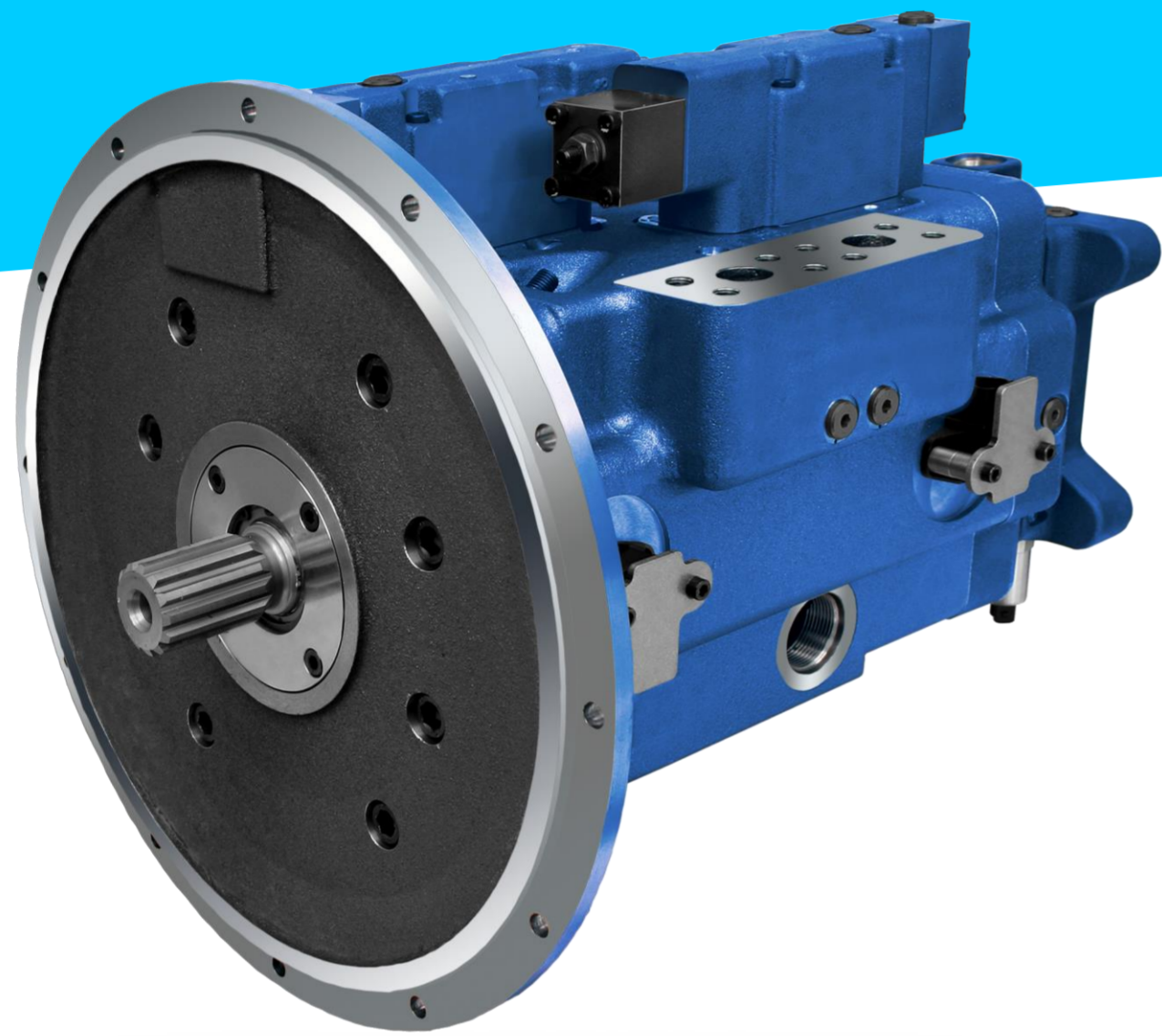

Stricter emission regulations require new generations of diesel engines to be equipped with modern exhaust gas after-treatment systems. These combustion engines and the additional components need more fitment space than previous generations. Moreover, these engines show a different performance characteristic. As a result, there is less space available for the hydraulics and the hydraulic components have to be more efficient in order to maintain or increase today's productivity of working machinery. The Rexroth A28VO series 10 axial piston variable double pump offers convincing arguments: its short installation length is unmatched, it is highly efficient and it offers a multitude of options for the use in excavators, mobile cranes, drilling equipment and forestry machinery.

## CUSTOMER BENEFITS

- Shortest double pump for limited installation space
- High efficiency and reduced fuel consumption
- Increased pressure level for maximum power density
- Proven swashplate design for heavy duty applications
- Versatile range of options

## FUNCTION AND BENEFITS

### Shortest double pump for limited installation space

In mobile working machines the space available for components is basically determined by the dimensions of the vehicle. Taking the example of an excavator, whose drive motor is transversely positioned, this means that the width of the superstructure defines the maximum length for the arrangement of the fan system, the diesel motor, and the hydraulic units. Compactness in the design of hydraulic components is therefore an important requirement of manufacturers of construction machinery. The Rexroth A28VO variable double pump meets this requirement with its very short overall length by means of compact rotary groups and a through-drive compatible pilot pressure pump.

The Rexroth A28VO with a size of 2x130 cm<sup>3</sup> is up to 20 percent shorter than similar products available in the market – it is best in class. The short overall length and the option to mount additional pumps (e.g. for the fan drive) directly on the A28VO avoids additional costs for the otherwise necessary installation of a splitter gearbox.

## APPLICATIONS

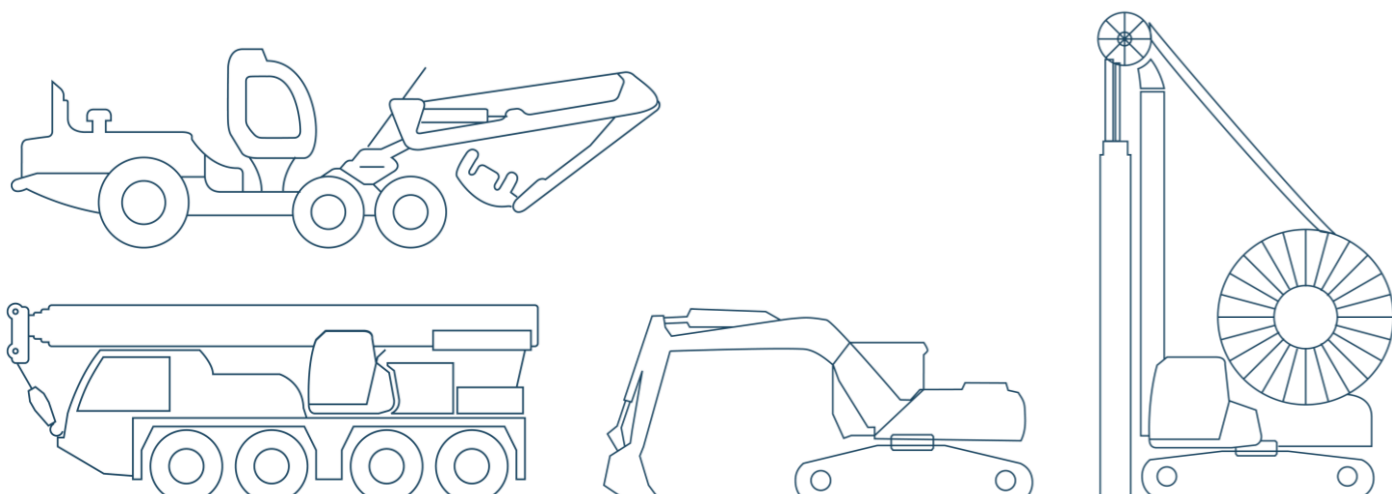

## A28VO axial piston variable double pump

Compact design and high efficiency

### TECHNICAL DATA

#### Axial piston variable double pump A28VO series 10

Size:	130 cm <sup>3</sup>	280 cm <sup>3</sup>
Nominal pressure:	380 bar	350 bar
Maximum pressure:	420 bar	420 bar
Speed:	2200 rpm	1900 rpm
Flange:	SAE J617 409-12	SAE J744 165-4
Shaft:	1 3/4 in 13 T 8/16 DP	2 1/4 in 17 T 8/16 DP
Control device:	power control, pressure control, proportional control	
Installation length (without pilot pressure pump):	440 mm	766 mm
Data sheet:	93110 (in preparation)	

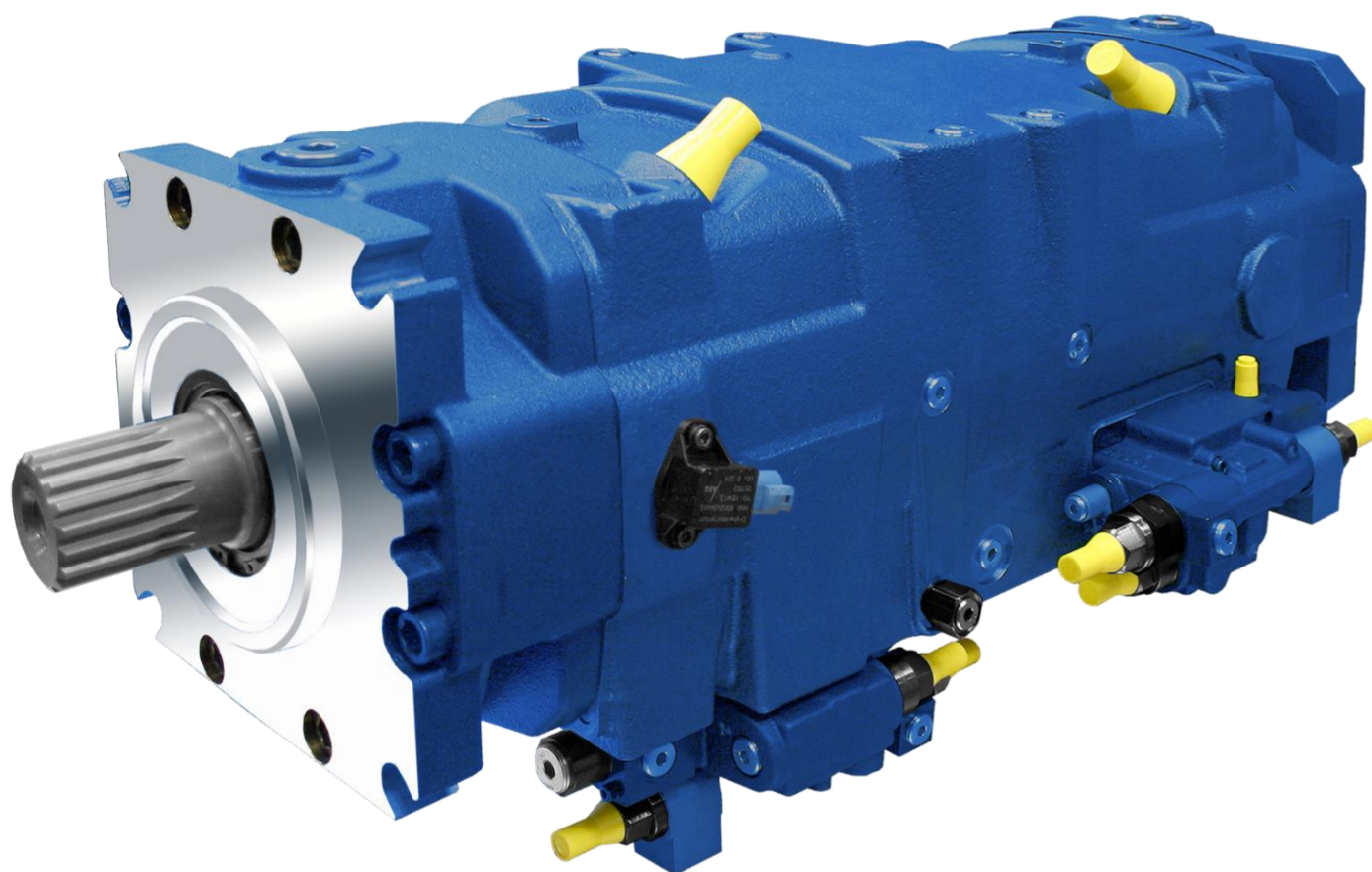

Rexroth A28VO size 280 with power controller in back-to-back design.

#### High efficiency and reduced fuel consumption

The Rexroth A28VO series 10 double pump features optimized rotary groups which improve the overall efficiency by 3 to 5 percent compared to common hydraulic pumps. Moreover, the Rexroth A28VO double pump has an up to 20 bar higher maximum pressure level. The same hydraulic power can therefore be transferred with less flow. Flow losses in the hydraulic system are also reduced and the overall efficiency of the mobile working machine is increased. The same hydraulic power can be transferred using less power consumption. The operators of working machines e.g. excavators, mobile cranes benefit from this as fuel consumption and therefore operating costs are reduced.

#### Versatile range of options

Bosch Rexroth offers a wide range of control devices for the A28VO series 10 axial piston pump (e.g. power control, pressure control, proportional control), sensors, through-drives, and mounting flanges. This broad product portfolio allows the A28VO to be used in different hydraulic systems and customer applications.

#### Proven and reliable design

Rexroth has many years of experience in the development and production of high quality hydraulic pumps in swashplate design for demanding customer applications e.g. construction and forestry machinery. This comprehensive expertise has been applied in the development of the Rexroth A28VO series 10.