

Axial Piston Variable Double Pump A22VG

Series 40

Instruction manual
RE 93221-01-B/07.2013

Replaces: --
English

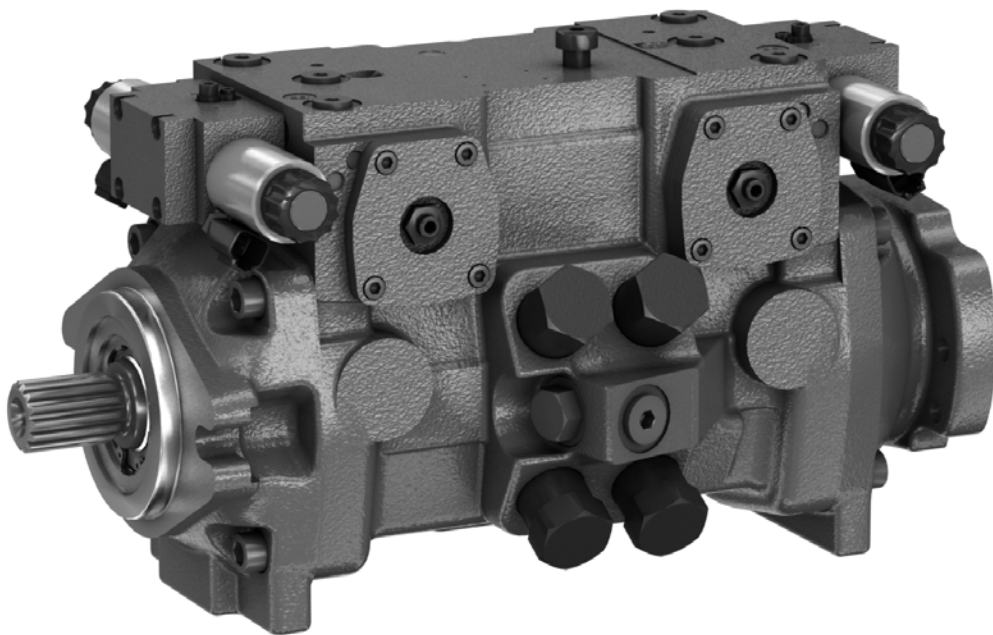

The data specified above serve to describe the product. Should information be provided on use, these are only examples of applications and suggestions. Information from the catalog are not assured properties. The information given does not release the user from the obligation of own judgment and verification. Our products are subject to a natural wear and aging process.

© This document, as well as the data, specifications and other information set forth in it, are the exclusive property of Bosch Rexroth AG. It may not be reproduced or given to third parties without its consent.

The cover shows an example application. The product delivered may differ from the image on the cover.

The original instruction manual was created in the German language.

Contents

1	About this documentation	5
1.1	Validity of the documentation	5
1.2	Required and supplementary documentation	5
1.3	Display of information	6
1.3.1	Safety instructions	6
1.3.2	Symbols	6
1.3.3	Designations	7
1.3.4	Abbreviations	7
2	Safety instructions	8
2.1	About this chapter	8
2.2	Intended use	8
2.3	Improper use	8
2.4	Personnel qualifications	9
2.5	General safety instructions	9
2.6	Product-specific safety instructions	10
2.7	Personal protection equipment	12
3	General instructions on damage to equipment and the product	13
4	Scope of supply	16
5	Product description	17
5.1	Performance description	17
5.2	Product description	17
5.2.1	Assembly of the axial piston unit	17
5.2.2	Functional description	18
5.3	Product identification	19
6	Transport and storage	20
6.1	Transporting the axial piston unit	20
6.1.1	Transporting by hand	20
6.1.2	Transporting with lifting device	20
6.2	Storing the axial piston unit	22
7	Installation	24
7.1	Unpacking	24
7.2	Installation conditions	24
7.3	Installation position	26
7.3.1	Below-reservoir installation (standard)	26
7.3.2	Above-reservoir installation	27
7.4	Installing the axial piston unit	28
7.4.1	Preparation	28
7.4.2	Dimensions	29
7.4.3	General instructions	29
7.4.4	Installation with coupling	30
7.4.5	Installation on a gearbox	30
7.4.6	Installation with cardan shaft	31
7.4.7	Completing installation	31
7.4.8	Hydraulically connecting the axial piston unit	33
7.4.9	Electrically connecting the axial piston unit	38
7.5	Performing flushing cycle	38

8	Commissioning	39
8.1	Initial commissioning	39
8.1.1	Filling the axial piston unit	39
8.1.2	Testing the hydraulic fluid supply	41
8.1.3	Performing functional test	41
8.2	Running-in phase	42
8.3	Recommissioning after standstill	42
9	Operation	43
10	Maintenance and repair	43
10.1	Cleaning and care	43
10.2	Inspection	44
10.3	Maintenance	44
10.4	Repair	45
10.5	Spare parts	45
11	Removal and replacement	46
11.1	Required tools	46
11.2	Preparing for removal	46
11.3	Removal of the axial piston unit	46
11.4	Preparing the components for storage or further use	46
12	Disposal	47
13	Extension and conversion	47
14	Troubleshooting	48
14.1	How to proceed for troubleshooting	48
14.2	Malfunction table	49
15	Technical data	51
16	Alphabetical index	52

1 About this documentation

1.1 Validity of the documentation

This documentation applies to the following products:

- Axial piston variable double pump A22VG series 40

This documentation is intended for machine/system manufacturers, fitters and service technicians.

This documentation contains important information on the safe and appropriate transport, installation, commissioning, operation, maintenance, removal and simple troubleshooting of the axial piston unit.

- ▶ Read this documentation completely and in particular the chapter 2 “Safety instructions” on page 8 and chapter 3 “General instructions on damage to equipment and the product” on page 13 before you start work with the axial piston unit.

1.2 Required and supplementary documentation







- ▶ Only commission the axial piston unit if the documentation marked with the book symbol  is available to you and you have understood and observed it.

Table 1: Required and supplementary documentation

Title	Document number	Document type
 Order confirmation Contains the order-related technical data of your A22VG axial piston variable double pump.	–	Order confirmation
 Installation drawing Contains the outer dimensions, all ports and the hydraulic schematic for your axial piston variable double pump A22VG.	Please request the installation drawing via your contact person at Bosch Rexroth.	Installation drawing
 Axial piston variable double pump A22VG Contains the permissible technical data.	93221	Data sheet
 Mineral-oil based hydraulic fluids and related hydrocarbons Describes the requirements on a mineral-oil based hydraulic fluid and related hydrocarbons for the operation with Rexroth hydraulic components, and assists you in selecting a hydraulic fluid for your hydraulic system.	90220	Data sheet
 Environmentally acceptable hydraulic fluids Describes the requirements on an environmentally acceptable hydraulic fluid for operation with Rexroth hydraulic components and assists you in selecting a hydraulic fluid for your hydraulic system.	90221	Data sheet
 Fire-resistant, water-free hydraulic fluids (HFDR/HFDR) Describes the requirements on fire-resistant, water-free hydraulic fluids for operation with Rexroth hydraulic components and assists you in selecting a hydraulic fluid for your hydraulic system.	90222	Data sheet
Notes on the use of hydrostatic drives at low temperatures Contains additional information on the use of Rexroth axial piston units at low temperatures.	90300-03-B	Manual
Storage and preservation of axial piston units Contains additional information on storage and preservation.	90312	Data sheet

1.3 Display of information

Standardized safety instructions, symbols, terms and abbreviations are used so that you can use this documentation to work quickly and safely with your product. To give you a better understanding they are explained in the sections below.

1.3.1 Safety instructions



This documentation includes safety instructions in chapter 2.6 “Product-specific safety instructions” on page 49 and in chapter 3 “General instructions on damage to equipment and the product” on page 13 and before a sequence of actions or an instruction for action involving a risk of personal injury or damage to equipment. The described danger prevention measures must be observed.

Safety instructions are set out as follows:

 SIGNAL WORD
<p>Type and source of danger! Consequences in case of noncompliance</p> <ul style="list-style-type: none"> ▶ Measure for danger prevention ▶ <List>

- **Warning sign:** draws attention to the danger
- **Signal word:** identifies the degree of the danger
- **Type and source of danger:** identifies the type and source of the danger
- **Consequences:** describes what occurs if the safety instructions are not complied with
- **Precautions:** states how the danger can be avoided

Table 2: Danger classes in accordance with ANSI Z535.6-2006

Warning sign, signal word	Meaning
 DANGER	Identifies a dangerous situation that will result in death or serious injuries if it is not avoided.
 WARNING	Identifies a dangerous situation that may result in death or serious injuries if it is not avoided.
 CAUTION	Identifies a dangerous situation that may result in minor to moderate injuries if it is not avoided.
NOTE	Damage to equipment: the product or the environment may be damaged.

1.3.2 Symbols

The following symbols mark notes that are not safety-relevant but which increase the understanding of the documentation.

Table 3: Meaning of the symbols

Symbol	Meaning
	If this information is disregarded, the product can not be used and/or operated to the optimum extent.
▶	Single, independent step
1.	Numbered instruction:
2.	The numbers specify that the steps are completed one after the other.
3.	

1.3.3 Designations

This documentation uses the following designations:

Table 4: Designations

Designation	Meaning
A22VG	Axial piston variable double pump, closed circuit
Threaded plug	Metal screw, pressure-resistant
Protection plug	Made out of plastic, not pressure-resistant, only for transportation

As umbrella term for “A22VG axial piston variable double pump” the designation “axial piston unit” will be used in the following.

1.3.4 Abbreviations

This documentation uses the following abbreviations:

Table 5: Abbreviations

Abbreviation	Meaning
ATEX	EU directive for explosion protection (A tmosphère e xplosible)
DIN	D eutsche I ndustrie N orm (German Institute for Standardization)
EP	Proportional control electric
ET	Electric control, direct controlled
HT	Hydraulic control, direct controlled
HW	Proportional control, hydraulic, mechanical servo
ISO	I nternational O rganization for S tandardization
JIS	J apan I ndustrial S tandard
RE	R exroth document in the E nglish language
VDI 2230	Directive for the systematic calculation of high duty bolted joints and joints with one cylindrical bolt from the VDI (V erein D eutscher I ngenieure – A ssociation of German Engineers)

2 Safety instructions

2.1 About this chapter

The axial piston unit has been manufactured according to the generally accepted rules of current technology. There is, however, still a danger of personal injury or damage to equipment if this chapter and the safety instructions in this documentation are not complied with.

- ▶ Read this documentation completely and thoroughly before working with the axial piston unit.
- ▶ Keep this documentation in a location where it is accessible to all users at all times.
- ▶ Always include the required documentation when you pass the axial piston unit on to third parties.

2.2 Intended use

Axial piston units are hydraulic components, meaning that in their application area they are classified neither as complete nor as incomplete machines in the sense of the EU machine directive 2006/42/EC. A component is exclusively intended to form an incomplete or a complete machine together with other components. The component may only be commissioned after it has been installed in the machine/system for which it is intended and the safety of the entire system has been established in accordance with the machine directive.

The product is intended for the following use:

The axial piston unit is only approved as a pump for hydrostatic drives in closed circuit.

- ▶ Observe the technical data, application and operating conditions and performance limits as specified in data sheet 93221 and in the order confirmation. Information about approved hydraulic fluids can be found in data sheet 93221.

The axial piston unit is only intended for professional use and not for private use. Intended use includes having read and understood the complete documentation, especially the chapter 2 “Safety instructions” on page 8.

2.3 Improper use

Any use other than that described as intended use shall be considered as improper and is therefore impermissible.

Bosch Rexroth AG shall accept no liability whatsoever for damage resulting from improper use. The user shall bear all risks arising from improper use.

Similarly, the following foreseeable faulty usages are also considered to be improper:

- Use outside the operating parameters approved in the data sheet or in the order confirmation (unless customer-specific approval has been granted)
- Use for non-approved fluids, e.g. water or polyurethane components
- Modification of factory settings by non-authorized persons
- Use of add-on parts (e.g. control unit, valves) that are not specified Rexroth components
- Using the axial piston unit under water at a depth of more than 10 meters without necessary additional measures, e.g. pressure equalization

- Using the axial piston unit when the exterior pressure is greater than the interior pressure (case pressure)
- Using the axial piston unit in explosive environments unless the component or machine/system has been certified as compliant with the ATEX directive 94/9/EC
- Using the axial piston unit in an aggressive atmosphere
- Using the axial piston unit in aircraft or space craft

2.4 Personnel qualifications

The activities described in this documentation require basic mechanical, electrical and hydraulic knowledge, as well as knowledge of the associated technical terms. For transporting and handling the product, additional knowledge is necessary with regard to working with a lifting device and the corresponding attachment equipment. In order to ensure safe use, these activities may therefore only be carried out by appropriate qualified personnel or an instructed person under the direction and supervision of qualified personnel.

Qualified personnel are those who can recognize possible hazards and institute the appropriate safety measures due to their professional training, knowledge, and experience, as well as their understanding of the relevant regulations pertaining to the work to be done. Qualified personnel must observe the rules relevant to the subject area and have the necessary hydraulic knowledge.

Hydraulic knowledge means, for instance:

- reading and fully understanding hydraulic plans,
- fully understanding in particular the interrelationships regarding safety devices, and
- having knowledge on the function and assembly of hydraulic components.



Bosch Rexroth offers training support for special fields. You can find an overview of the training contents on the internet at: <http://www.boschrexroth.de/didactic>.

2.5 General safety instructions

- Observe the applicable accident prevention and environmental protection regulations.
- Observe the safety regulations and provisions of the country in which the product is used/operated.
- Use Rexroth products only when they are in good technical order and condition.
- Observe all notes on the product.
- Persons who install, operate, remove or maintain Rexroth products must not consume any alcohol, drugs or pharmaceuticals that may affect their ability to respond.
- Only use Rexroth original accessories and spare parts to ensure there is no risk to persons from unsuitable spare parts.
- Conform to the technical data and ambient conditions specified in the product documentation.
- If unsuitable products are installed or used in applications that are of relevance to safety, unexpected operating conditions may occur in the application which could result in injury to persons or property damage. For this reason, only use the product in a safety-relevant application if this use is expressly specified and

permitted in the product documentation, for example in ex-protection applications or in safety-related parts of a control system (functional safety).

- You may only commission the product if it has been determined that the end product (e.g. machinery or a system) into which the Rexroth products are installed complies with the country-specific provisions, safety regulations and standards of the application.

2.6 Product-specific safety instructions

The following safety instructions apply for chapters 6 to 14.

WARNING

Danger from excessively high pressure!

Danger to life or risk of injury, damage to equipment!

Incorrectly changing the factory pressure setting can cause pressure to increase beyond the permissible maximum pressure.

Operating the unit above the permissible maximum pressure can cause components to burst and hydraulic fluid to escape under high pressure.

- ▶ Changes to the factory settings must only be made by Bosch Rexroth specialist personnel.
- ▶ In addition, a pressure-relief valve is needed as back-up in the hydraulic system. If the axial piston unit is equipped with a pressure cut-off and/or a pressure controller, this is not an adequate back-up against pressure overload.

WARNING

Danger from suspended loads!

Danger to life or risk of injury, damage to equipment!

Improper transportation may cause the axial piston unit to fall down lead to injuries e.g. crushing or broken bones or damage to the product.

- ▶ Make certain that the forklift truck or lifting device has adequate lifting capacity.
- ▶ Never stand under or put you hands under suspended loads.
- ▶ Ensure your position is stable during transportation.
- ▶ Use your personal protection equipment (e.g. safety glasses, safety gloves, suitable working clothes, safety shoes).
- ▶ Use suitable lifting devices for transportation.
- ▶ Observe the prescribed position of the lifting strap.
- ▶ Observe the national laws and regulations on work and health protection and transportation.

Pressurized machine/system!

Danger to life or risk of injury, serious injuries when working on machines/systems not shutdown! Damage to equipment!

- ▶ Protect the complete system against being energized.
- ▶ Make sure that the machine/system is depressurized. Please follow the machine/system manufacturer's instructions.
- ▶ Do not disconnect any line connections, ports and components when the machine/system is pressurized.
- ▶ Switch off all power-transmitting components and connections (electric, pneumatic, hydraulic, mechanical) in accordance with the manufacturer's instruction and secure them against being switched back on.

Escaping oil mist!

Risk of explosion, fire, health hazard, environmental pollution!

- ▶ Depressurize the machine/system and repair the leak.
- ▶ Only perform welding work then the machine/system is depressurized.
- ▶ Keep open flames and ignition sources away from the axial piston unit.
- ▶ If axial piston units are to be situated in the vicinity of ignition sources or powerful thermal radiators, a shield must be erected to ensure that any escaped hydraulic fluid can not ignite, and to protect hose lines from premature aging.

Electrical voltage!

Risk of injury due to electric shock or damage to equipment!

- ▶ Always set up the relevant part of the machine/system so that it is free of electrical voltage before you install the product or when connecting and disconnecting plugs. Protect the machine/system against being energized.

CAUTION

High noise development in operation!

Danger of hearing damage, deafness!

The noise emission of axial piston units depends on speed, operating pressure and installation conditions. The sound pressure level may rise above 70 dB(A) during normal application conditions.

- ▶ Always wear hearing protection when in the vicinity of the operating axial piston unit.

Hot surfaces on the axial piston unit!

Risk of burns!

- ▶ Allow the axial piston unit to cool down sufficiently before touching it.
- ▶ Wear heat-resistant protection clothing, e.g. gloves.

Improper routing of cables and lines!

Tripping danger and damage to equipment!

- ▶ Lay cables and lines so that they can not be damaged and nobody can trip over them.

Contact with hydraulic fluid!

Hazard to health/health impairment e.g. eye injuries, skin damage, toxication during inhalation!

- ▶ Avoid contact with hydraulic fluids.
- ▶ When working with hydraulic fluids, strictly observe the safety instructions provided by the lubricant manufacturer.
- ▶ Use your personal protection equipment (e.g. safety glasses, safety gloves, suitable working clothes, safety shoes).
- ▶ If hydraulic fluid should, nevertheless, come into contact with your eyes or bloodstream or is swallowed, consult a doctor immediately.

Escaping hydraulic fluid due to machine/system leakage!

Risk of burns and risk of injury due to escaping oil jet!

- ▶ Depressurize the machine/system and repair the leak.
- ▶ Never attempt to block or seal the leak or oil jet with a cloth.

2.7 Personal protection equipment

The personal protection equipment is the responsibility of the user of the axial piston unit. Observe the safety regulations and provisions of your country.

All components of the personal protection equipment must be intact.

3 General instructions on damage to equipment and the product

The following instructions apply for chapters 6 to 14.

NOTE

Danger from improper handling!

Product can be damaged!

- ▶ Do not expose the product to an impermissible mechanical load.
- ▶ Never use the product as a handle or step.
- ▶ Do not place/lay any objects on the product.
- ▶ Do not strike the drive shaft of the axial piston unit.
- ▶ Do not set/place the axial piston unit on the drive shaft or fittings.
- ▶ Do not strike fittings (e.g. sensors or valves).
- ▶ Do not strike sealing surfaces (e.g. service line ports).
- ▶ Leave the protection covers on the axial piston unit until shortly before the lines are connected.
- ▶ Disconnect all electrical connectors before performing electro-welding or painting operations.
- ▶ Make certain that the electronic components (e.g., sensors) do not become electrostatically charged (e.g., during painting operations).

Damage to equipment due to improper lubrication!

Product can be damaged or destroyed!

- ▶ Never operate the axial piston unit with insufficient hydraulic fluid. Make sure in particular that the rotary group has sufficient lubrication.
- ▶ When commissioning a machine/system, make sure that the housing and the service lines of the axial piston unit are filled with hydraulic fluid and remain filled during operation.
- ▶ Check the hydraulic fluid level in the housing regularly; if necessary, recommission. With above-reservoir installation, the housing may drain via the reservoir line after longer standstill periods (air enters via the shaft seal) or via the service line (gap leakage). The bearings are thus insufficiently lubricated at switch on.
- ▶ Make sure that the suction line is always filled with hydraulic fluid during commissioning and operation.

NOTE

Mixing of hydraulic fluids!

Product can be damaged!

- ▶ Before installation, remove all fluids from the axial piston unit to prevent mixing with the hydraulic fluid used in the machine/system.
- ▶ Any mixing of hydraulic fluids of different manufacturers or different types of the same manufacturer is not permissible in general.

Contamination of the hydraulic fluid!

The cleanliness of the hydraulic fluid has a considerable impact on the cleanliness and service life of the hydraulic system. Contamination of the hydraulic fluid could cause premature wear and malfunctions!

- ▶ Make sure that the working environment at the installation site is fully free of dust and foreign substances in order to prevent contaminants, such as welding beads or metal cuttings, from getting into the hydraulic lines and causing product wear or malfunctions. The axial piston unit must be installed in a clean condition.
- ▶ Use only clean ports, hydraulic lines and attachments (e.g. measuring devices).
- ▶ No contaminants may enter the ports when they are plugged.
- ▶ Before commissioning, make sure that all hydraulic connections are tight and that all of the connection seals and plugs are installed correctly to ensure that they are leakproof and fluids and contaminants are prevented from penetrating the product.
- ▶ Use a suitable filter system to filter hydraulic fluid during filling to minimize solid impurities and water in the hydraulic system.

Improper cleaning!

Product can be damaged!

- ▶ Plug all openings with the appropriate protection equipment in order to prevent detergents from entering the hydraulic system.
- ▶ Never use solvents or aggressive detergents. Use only water and, if necessary, a mild detergent to clean the axial piston unit.
- ▶ Do not point the high-pressure cleaner at sensitive components, e.g. shaft seal, electrical connections and components.
- ▶ Use lint-free cloths for cleaning.

Environmental pollution due to incorrect disposal!

Careless disposal of the axial piston unit and its fittings, the hydraulic fluid and the packaging material could lead to pollution of the environment!

- ▶ Dispose of the axial piston unit, hydraulic fluid and packaging in accordance with the national regulations in your country.
- ▶ Dispose of the hydraulic fluid in accordance with the applicable safety data sheet for the hydraulic fluid.

NOTE

Escaping or spilling hydraulic fluid!

Environmental pollution and contamination of the ground water!

- ▶ Always place a drip tray under the axial piston unit when filling and draining the hydraulic fluid.
- ▶ Use an oil binding agent if hydraulic fluid is spilled.
- ▶ Observe the information in the safety data sheet for the hydraulic fluid and the specifications provided by the system manufacturer.

The warranty applies only to the delivered configuration.

The entitlement to warranty cover will be rendered void if the product is incorrectly installed, commissioned or operated, or if it is used or handled improperly.

4 Scope of supply

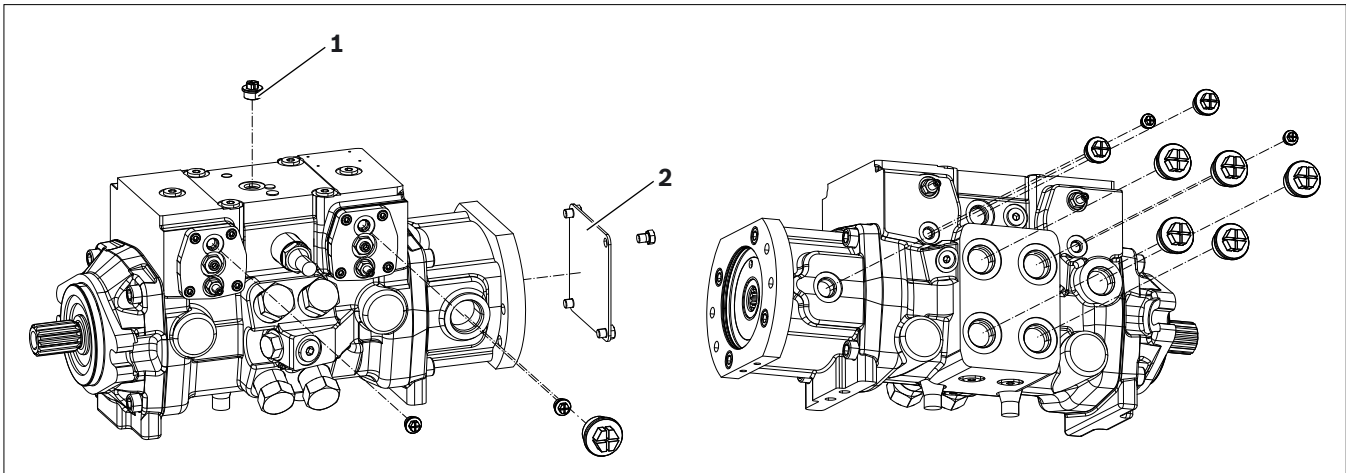

Fig. 1: Axial piston unit

Included in the scope of supply are:

- Axial piston unit as per order confirmation

The following parts are also installed on delivery:

- Protection plug/threaded plug (**1**)
- For version with through drive, metallic protection cover and mounting bolts (**2**)

5 Product description

5.1 Performance description

The axial piston variable double pump generates, controls and regulates a hydraulic-fluid flow. It is designed for mobile applications such as construction machinery. Refer to data sheet 93221 and the order confirmation for the technical data, operating conditions and operating limits of the axial piston unit.

5.2 Product description

The A22VG is a variable double pump with two axial piston rotary groups in swashplate design for hydrostatic drives in closed circuits. The two flows are proportional to the drive speed and the displacement. The flow can be steplessly changed by controlling the cradle (11). Both circuits can be adjusted independent of one another. For axial piston units with swashplate design, the pistons are arranged axially with respect to the drive shaft.

Closed circuit

In the closed circuit, the hydraulic fluid flows from the hydraulic pump to the consumer (e.g. the hydraulic motor) and from there directly back to the hydraulic pump.

There is a high-pressure side and a low-pressure side which alternate depending on which side is under load.

5.2.1 Assembly of the axial piston unit

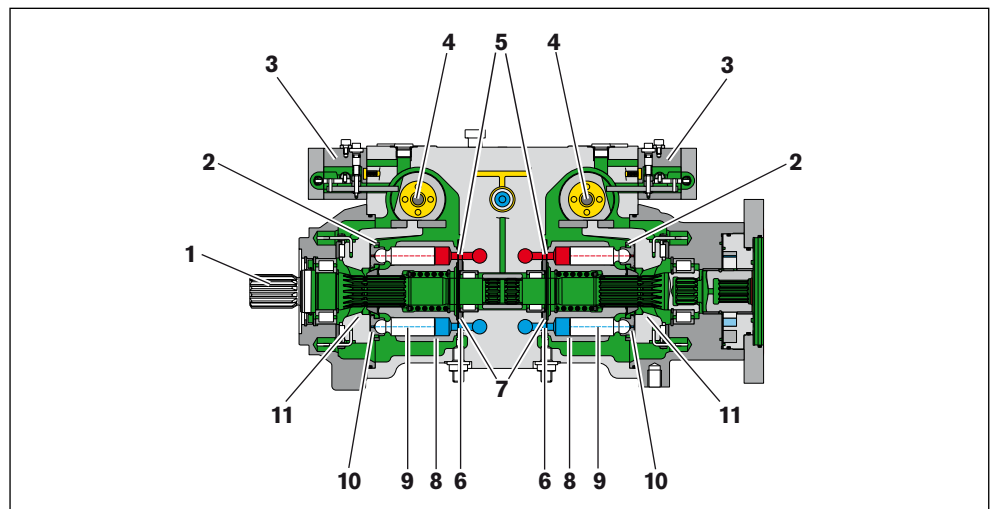

Fig. 2: Assembly of the A22VG

1 Drive shaft	4 Stroking piston	8 Cylinder
2 Retainer plate	5 High-pressure side	9 Piston
3 Controller (using the EP as an example here)	6 Low-pressure side	10 Slipper pad
	7 Control plate	11 Cradle

5.2.2 Functional description

Pump Torque and rotational speed are applied to the drive shaft (1) by an diesel engine. The drive shaft is connected by splines to the cylinder (8) to set this in motion. With every revolution, the pistons (9) in the cylinder bores execute one stroke whose magnitude depends on the setting of the cradle (11). The pistons hold the slipper pads (10) onto the glide surface of the cradle with the retainer plate (2) and guide them along. The swashplate setting during a rotation causes each piston to move over the bottom and top dead centers and back to its initial position. Here, hydraulic fluid is fed in and drained out through the two control slots in the control plate (7) according to the stroke displacement. On the high-pressure side (5) the hydraulic fluid is pushed out of the cylinder chamber and into the hydraulic system by the pistons. At the same time, hydraulic fluid flows into the growing piston chamber on the low-pressure side (6). In a closed circuit, supported by the return and boost pressure.

High-pressure safeguarding The four high-pressure relief valves protect the hydrostatic transmission (pump and engine) against overloading. They limit the maximum pressure in the relevant high-pressure line and at the same time act as boost valves. High-pressure relief valves are not working valves and are only suitable for pressure spikes or high rates of pressure change.

Version without boost pump In order to replenish internal leakage in the variable double pump and consumers, port **G** must be connected to an external source of boost pressure. The boost pressure-relief valve is integrated.

Version with boost pump (optional) The boost pump continuously supplies a volume of fluid (boost volume) from a reservoir to the low-pressure side of the closed circuit via a check valve to replenish the internal leakage of the variable double pump and consumers. The boost pump is an internal gear pump, driven directly via the drive shaft.



Pressure port **G₂** on the boost pump must be externally piped up by the customer to port **G** (or **G₁** on the version with DA control valve). Suction or pressure filtration must be provided by the customer.

Control The swivel angle of the cradle (11) is steplessly varied. Controlling the swivel angle of the swashplate changes the piston stroke and therefore the displacement. Adjusting the swashplate through the neutral position will change the direction of flow (making reversing operation possible). The swivel angle is controlled hydraulically by means of the stroking piston. The cradle is mounted in swivel bearings for easy motion and the neutral position is spring-centered. Increasing the swivel angle increases the displacement; reducing the angle results in a corresponding reduction in displacement.



Various control devices are available depending on requirements. Information about this can be found in data sheet 93221.

! CAUTION

The spring feedback feature in the control module is not a safety device

The control module can stick in an undefined position due to internal contamination (contaminated hydraulic fluid, abrasion or residual contamination from system components). As a result, the volume flow of the axial piston unit will no longer respond correctly to the operator's commands.

- ▶ Check whether the application on your machine requires additional safety measures, in order to bring the driven consumer into a safe position (immediate stop). If necessary, make sure that these are properly implemented.

5.3 Product identification

The axial piston unit can be identified from the name plate. The following example shows an A4VG A22VG name plate:

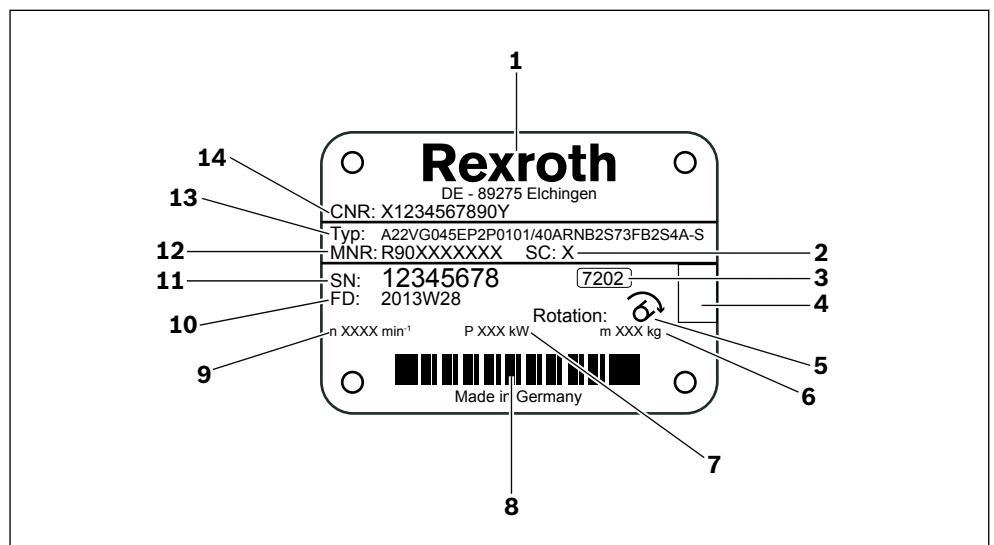

Fig. 3: Name plate A22VG

- | | |
|--|--|
| 1 Manufacturer | 8 Bar code |
| 2 Sample category (optional) | 9 Rotational speed |
| 3 Internal plant designation | 10 Manufacturing date |
| 4 Specified area for inspection stamp | 11 Serial number |
| 5 Direction of rotation (viewed on drive shaft) – here: clockwise | 12 Material number of the axial piston unit |
| 6 Weight (optional) | 13 Ordering code |
| 7 Power | 14 Customer material number |

6 Transport and storage

- ▶ Always observe the required ambient conditions for transport and storage, see chapter 6.2 “Storing the axial piston unit” on page 22.



Notes on unpacking can be found in chapter 7.1 “Unpacking” on page 24.

6.1 Transporting the axial piston unit

The transportation options below exist depending on the weight and duration of the transport:

- Transport by hand (chapter not relevant for this axial piston unit)
- Transporting with lifting device (eye bolt or lifting strap)

Dimensions and weights

Table 6: Dimensions and weights

Size		45
Weight	kg	53 ¹⁾
Width	mm	The dimensions vary with the unit type. The values applicable for your axial piston unit can be found in the installation drawing (request if necessary).
Height	mm	
Depth	mm	

¹⁾ With HT control without boost pump.

The weight specifications may vary depending on the unit type.

6.1.1 Transporting by hand

Axial piston units with a weight of up to 15 kg can be transported manually for a short time if necessary.

CAUTION! Danger from heavy loads!

There is a danger of health damage when carrying axial piston units.

- ▶ Use suitable lifting, placement and relocation equipment.
- ▶ Use your personal protection equipment (e.g. safety glasses, safety gloves, suitable working clothes, safety shoes).
- ▶ Do not transport the axial piston unit at sensitive attachment parts (e.g. sensors or valves).
- ▶ Carefully place the axial piston unit on the seating to prevent it from being damaged.

6.1.2 Transporting with lifting device

For transporting, the axial piston unit can be connected to a lifting device via a eye bolt or a lifting strap.

Transport with eye bolt

The axial piston unit can be transported suspended from a eye bolt screwed into the drive shaft as long as only outward (pulling) axial forces are applied.

- ▶ For all female threads, use a threaded plug from the same system of units and of the correct size.
- ▶ To do this, screw a eye bolt completely into the female thread on the drive shaft. The thread size is stated in the installation drawing.
- ▶ Make sure that the eye bolt can bear the total weight of the axial piston unit plus 20 %.

You can hoist the axial piston unit as shown in Fig. 4 with the eye bolt screwed into the drive shaft.

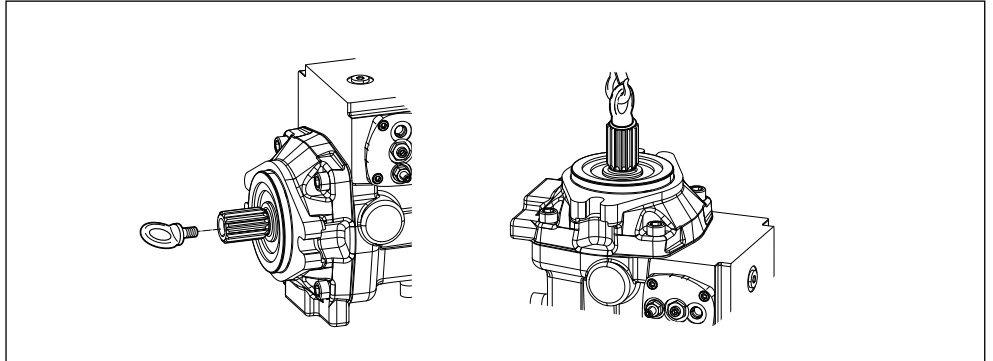

Fig. 4: Fixing the eye bolt

Transport with lifting strap

WARNING! Danger from suspended loads!

During transport with a lifting device, the axial piston unit can fall out of the lifting strap and cause injuries.

- ▶ Use the widest possible lifting strap.
- ▶ Make sure that the axial piston unit is securely fixated with the lifting strap.
- ▶ Only guide the axial piston unit by hand for fine positioning and to avoid oscillations.
- ▶ Never stand under or put your hands under suspended loads.
- ▶ Place the lifting strap around the axial piston unit in such a way that it neither passes over the attachment parts (e.g. valves) nor that the axial piston unit is hung from attachment parts (see Fig. 5).

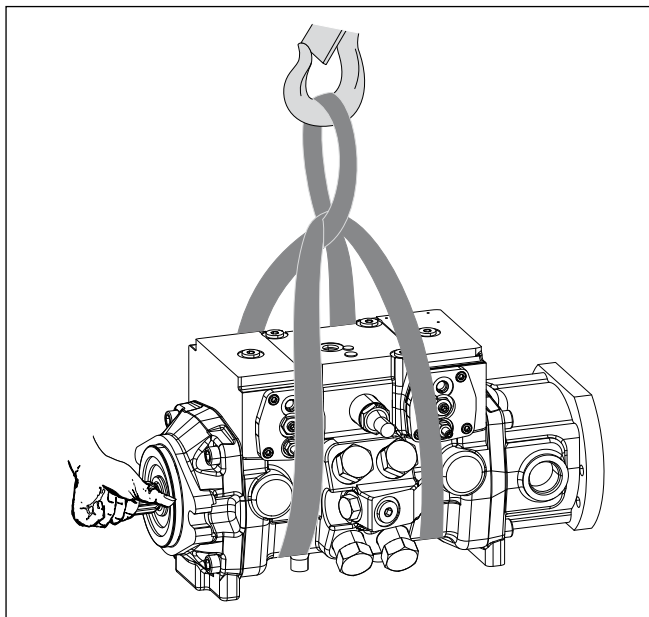

Fig. 5: Transport with lifting strap

6.2 Storing the axial piston unit

Requirement

- The storage areas must be free from corrosive materials and gases.
 - To prevent damage to the seals, ozone-forming equipment (e.g. mercury-vapor lamps, high voltage equipment, electric motors, sources of electrical sparks or electrical discharges) must not be operated in storage areas.
 - The storage areas must be dry.
 - Ideal storage temperature: +5 °C to +20 °C.
 - Minimum storage temperature: –50 °C (exception: units with on-board-electronics).
 - Maximum storage temperature: +60 °C.
 - Avoid high light irradiation (e.g. bright windows or direct fluorescent lighting).
 - Do not stack axial piston units and store them shock-proof.
 - Do not store the axial piston unit on the drive shaft or fitting, e.g. sensors or valves.
 - For further storage conditions, see Table 7.
- Check the axial piston unit monthly to ensure proper storage.

After delivery

The axial piston units are provided ex-works with corrosion protection packaging (corrosion protection film).

Table 7 lists the maximum permissible storage times for an originally packed axial piston unit as per data sheet 90312.

Table 7: Storage time with factory corrosion protection

Storage conditions	Standard corrosion protection	Long-term corrosion protection
Closed, dry room, uniform temperature between +5 °C and +20 °C. Undamaged and closed corrosion protection film.	Maximum 12 months	Maximum 24 months



Entitlement to warranty will be rendered void if the requirements and storage conditions are not adhered to or after expiration of the maximum storage time (see Table 7).

Procedure after expiry of the maximum storage time:

1. Check the entire axial piston unit for damage and corrosion prior to installation.
2. Check the axial piston unit for proper function and leaks during a test run.
3. If the storage time exceeds 24 months, the shaft seal ring must be replaced.



After expiry of the maximum storage time, we recommend that you have the axial piston unit inspected by your responsible Bosch Rexroth Service partner.

In the event of questions regarding repair and spare parts, contact your responsible Bosch Rexroth Service partner or the service department of the manufacture's plant for the axial piston unit, see chapter 10.5 "Spare parts" on page 45.

After removal If a removed axial piston unit is to be stored, it must be preserved against corrosion for the duration of storage.



The following instructions only refer to axial piston units which are operated with a mineral-oil based hydraulic fluid. Other hydraulic fluids require preservation methods that are specifically designed for them. In such cases, consult with Bosch Rexroth Service, see chapter 10.5 “Spare parts” on page 45.

Bosch Rexroth recommends the following procedure:

1. Clean the axial piston unit, see chapter 10.1 “Cleaning and care” on page 43.
2. Empty the axial piston unit.
3. For storage time up to 12 months: Moisten the inside of the axial piston unit with mineral oil and fill with approx. 100 ml mineral oil.
For storage time up to 24 months: Fill the axial piston unit with corrosion protection medium VCI 329 (20 ml).
Filling is performed via the reservoir port **T**, see chapter 7.4 “Installing the axial piston unit”, Fig. 13 and 14 on page 35.
4. Seal all ports airproof.
5. Moisten the unpainted surfaces of the axial piston unit with mineral oil or a suitable, easily removed corrosion protection agent, e.g. acid-free grease.
6. Package the axial piston unit airproof together with desiccant in corrosion protection film.
7. Store the axial piston unit so that it is protected against jolts, see “Requirement” on page 22 in this chapter.

7 Installation

Prior to installation, the following documents must be ready at hand:

- Installation drawing for axial piston unit (can be obtained from your responsible contact person at Bosch Rexroth)
- Hydraulic schematic for the axial piston unit (in the installation drawing)
- Hydraulic schematic for the machine/system (available from the machine/system manufacturer)
- Order confirmation (contains the order-related technical data for your axial piston unit)
- Data sheet of the axial piston unit (contains the permissible values of technical data)

7.1 Unpacking

The axial piston unit is delivered in a corrosion protection film made of polyethylene material (PE).

CAUTION! Danger from parts falling out!

If the packaging is not opened correctly, parts may fall out and damage the parts or even cause injuries!

- ▶ Place the packaging on a flat and solid surface.
- ▶ Only open the packaging from the top.

- ▶ Remove the packaging from the axial piston unit.
- ▶ Check the axial piston unit for transport damage and completeness, see chapter 4 “Scope of supply” on page 16.
- ▶ Dispose of the packaging according to the environmental regulations of your country.

7.2 Installation conditions

The installation location and position of the axial piston unit essentially determine the procedures during installation and commissioning (such as when filling and air bleeding the axial piston unit).

- ▶ Fix the axial piston unit so that the expected forces and torques can be transferred without any danger. The machine/system manufacturer is responsible for dimensioning the fasteners.



The variable double pump A22VG is permissible without additional supports, providing a maximum dynamic mass acceleration of $10 g$ ($= 98.1 \text{ m/s}^2$) is not exceeded. If an additional pump is to be fitted to the A22VG, the mounting flange must be calculated for the permissible moment of inertia.

- ▶ Observe the permissible radial forces on the drive shaft when transferring output drive with radial force loading (belt drives). If necessary, the belt pulley must be separately mounted.
- ▶ Make sure that the axial piston unit is air bled and filled with hydraulic fluid during commissioning and operation. This is also to be observed following relatively long standstill periods as the axial piston unit may empty via the hydraulic lines.

- ▶ The case drain fluid in the housing must be directed to the reservoir via the highest case drain port. Use the line size which is appropriate for the port.
- ▶ Avoid using a check valve in the reservoir line.
- ▶ To achieve favorable noise values, decouple all connecting lines from all vibration-capable components (e.g. reservoir) using elastic elements.
- ▶ Make sure that the suction, reservoir and return lines lead into the reservoir below the minimum fluid level in all operating conditions. This will prevent air from being drawn in and foam from being formed.
- ▶ Make sure that a minimum suction pressure of 0.8 bar absolute is present at port **S** during operation (0.5 bar absolute for cold starts) in all installation positions and installation locations for the axial piston pump, see Fig. 6. Please refer to the data sheet for further pressure values.

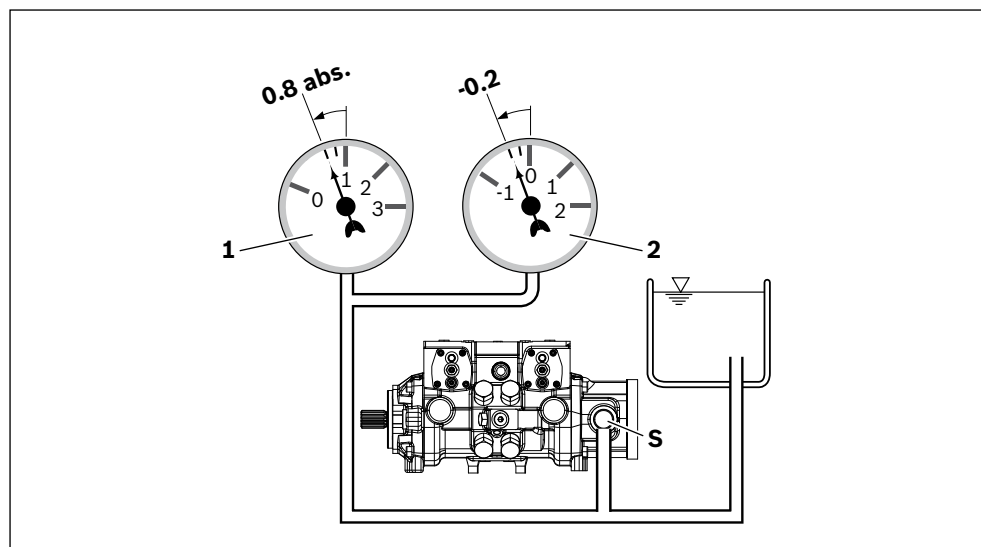

Fig. 6: Suction pressure

- 1** Absolute pressure gauge
- 2** Standard pressure gauge (relative)



The suction conditions improve with below-reservoir installation.

- ▶ Make sure that the working environment at the installation site is fully free of dust and foreign substances. The axial piston unit must be installed in a clean condition. Dirt contamination in the hydraulic fluid can seriously impair the function and service life of the axial piston unit.
- ▶ Use lint-free cloths for cleaning.
- ▶ Use suitable mild detergents to remove lubricants and other difficult-to-remove contamination. Cleaning agents must not enter the hydraulic system.

7.3 Installation position

The following installation positions are permissible. The shown piping layout illustrates the basic layout.



If it is not possible to fill the stroking chambers via X_1 to X_6 in the final installation position, this must be done prior to installation.



In order to prevent unexpected activation behavior and damage, the stroking chambers must be air bled via ports X_1 , X_2 or X_5 , X_6 or X_3 , X_4 , according to their installation position.



Please note that with HT control, port X_1 , X_2 is omitted and is replaced by X_5 , X_6 .

7.3.1 Below-reservoir installation (standard)

Below-reservoir installation means that the axial piston unit is installed outside of the reservoir below the minimum fluid level.



Recommended installation position: 1 and 2 (without boost pump)
3 and 4 (with boost pump)

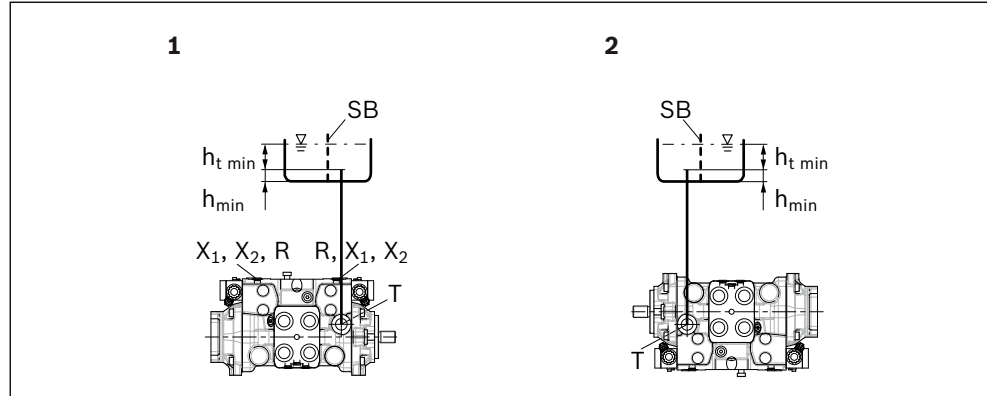

Fig. 7: Below-reservoir installation A22VG without boost pump, installation position 1-2

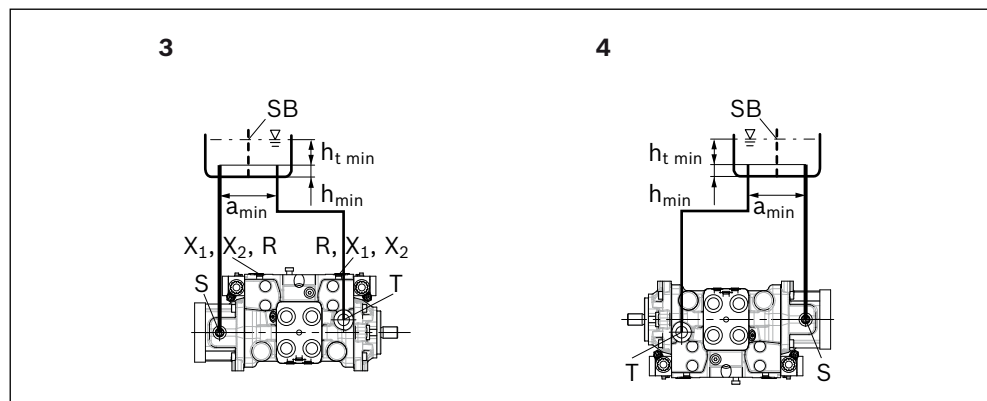

Fig. 8: Below-reservoir installation: A22VG with boost pump, installation position 3-4

R	Air bleed port	h_{min}	Minimum required spacing to reservoir bottom (100 mm)
S	Suction port	a_{min}	When designing the reservoir, ensure adequate distance between the suction line and the case drain line. This prevents the heated, return flow from being drawn directly back into the suction line.
T	Reservoir port (case drain)		
SB	Baffle (baffle plate)		
$h_{t min}$	Minimum required immersion depth (200 mm)		

Table 8: Below-reservoir installation

Installation position	Air bleeding the housing	Air bleed Stroking chamber	Filling
1 (drive shaft, horizontal)	R	X_1, X_2	$T + X_1 + X_2$
2 (drive shaft, horizontal)	–	–	T
3 (drive shaft, horizontal)	R	X_1, X_2	$S + T + X_1 + X_2$
4 (drive shaft, horizontal)	–	–	$S + T$

7.3.2 Above-reservoir installation

Above-reservoir installation means that the axial piston unit is installed above the minimum fluid level of the reservoir.



Observe the maximum permissible suction height $h_{s max} = 800$ mm. The permissible suction height h_s is derived from the total pressure loss.

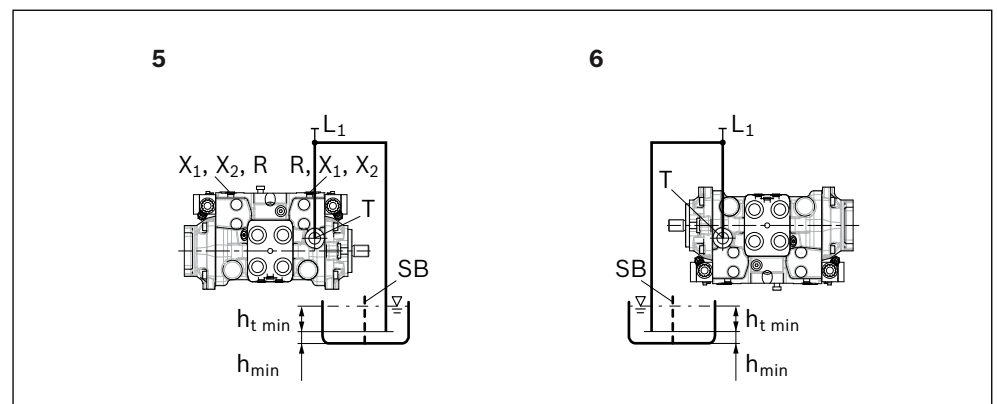

Fig. 9: Above-reservoir installation A22VG without boost pump, installation position 5-6

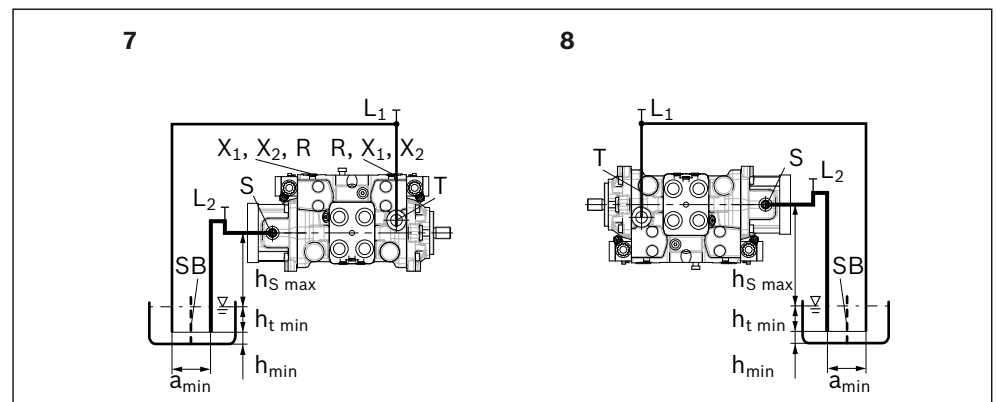

Fig. 10: Above-reservoir installation A22VG with boost pump, installation position 7-8

L	Filling / air bleed	h_{min}	Minimum required spacing to reservoir bottom (100 mm)
R	Air bleed port	h_{S max}	Maximum permissible suction height (800 mm)
S	Suction port	a_{min}	When designing the reservoir, ensure adequate distance between the suction line and the case drain line.
T	Reservoir port (case drain)		This prevents the heated, return flow from being drawn directly back into the suction line.
SB	Baffle (baffle plate)		
h_{t min}	Minimum required immersion depth (200 mm)		

Table 9: Above-reservoir installation

Installation position	Air bleeding the housing	Air bleed Stroking chamber	Filling
5 (drive shaft, horizontal)	R	X ₁ , X ₂	L ₁ + X ₁ + X ₂
6 (drive shaft, horizontal)	L ₁	–	L ₁
7 (drive shaft, horizontal)	R + L ₂ (S)	X ₁ , X ₂	L ₁ + L ₂ (S) + X ₁ + X ₂
8 (drive shaft, horizontal)	L ₁ + L ₂ (S)	–	L ₁ + L ₂ (S)

7.4 Installing the axial piston unit

7.4.1 Preparation

1. Compare the material number and designation (ordering code) with the details in the order confirmation.



If the material number for the axial piston unit does not correspond to the one in the order confirmation, contact Bosch Rexroth Service for clarification, see chapter 10.5 “Spare parts” on page 45.

2. Before installing, completely empty the axial piston unit to prevent any mixing with the hydraulic fluid used in the machine/system.

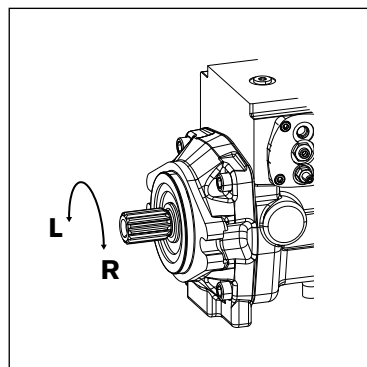
**Fig. 11: Direction of rotation**

- | | |
|----------|-------------------|
| L | Counter-clockwise |
| R | Clockwise |

3. Check the direction of rotation of the axial piston unit (on the name plate) and make sure that this corresponds to the direction of rotation of the output/drive shaft of the machine/system.



The direction of rotation as specified on the name plate determines the direction of rotation of the axial piston unit as viewed on the drive shaft, see chapter 5.3 “Product identification” on page 19.

7.4.2 Dimensions

The installation drawing contains the dimensions for all connections and ports on the axial piston unit. Also observe the instructions provided by the manufacturers of the other hydraulic components when selecting the required tools.

7.4.3 General instructions

Please keep in mind the following general instructions for installation of the axial piston unit:

- Note that you can expect certain installation positions to affect the control device. Gravity, dead weight and case pressure can cause minor shifts in control characteristics and changes in response time.
- Torsional vibrations and speed variations may cause leakages on the shaft seal and increased rotary angle accelerations of the rotary group of the axial piston unit. At risk are diesel drives with a small number of cylinders and low flywheel mass and toothed belt or V-belt drives. Belts can lose a large part of its tension after just a short time.

An automatic clamping device can lessen the speed variations and vibrations and thus avoid consequential damage.

– Always use an automatic clamping device when using toothed belts or V-belts to transfer the input or output drive.

- On the input or output drive of an axial piston unit, a cardan shaft may cause vibrations and impermissible rotary angle accelerations. Depending on the frequency and temperature, they may result in leakage on the shaft seal and damage to the rotary group.
- For combinations of multiple units, make sure that the respective case pressure in each unit is not exceeded. In the event of differential pressures at the drain ports of the units, the shared drain line must be changed so that the minimum permissible case pressure of all connected units is not exceeded in any situation. If this is not possible, separate drain lines must be laid if necessary.

How to install the axial piston unit depends on the connecting elements to the drive side. The following descriptions explain the installation of the axial piston unit:

- with a coupling
- on a gearbox

7.4.4 Installation with coupling

The method for installing the axial piston unit with a coupling is described below:

NOTE! Danger from improper handling!

Product can be damaged!

- ▶ Do not install the coupling hub onto the drive shaft of the axial piston unit by striking it.
1. Install the specified coupling half onto the drive shaft of the axial piston unit according to the instructions of the coupling manufacturer.



The drive shaft of the axial piston unit is equipped with a female thread. Use this female thread to pull the coupling element onto the drive shaft. The size of the female thread can be seen in the installation drawing.

2. Clamp the coupling hub onto the drive shaft or ensure permanent lubrication of the drive shaft. This prevents the formation of frictional corrosion and the associated wear.
3. Transport the axial piston unit to the installation location.
4. Remove dirt and contaminants from the installation location.
5. Install the coupling on the output shaft of the diesel engine in accordance with the specifications provided by the coupling manufacturer.



The axial piston unit may not be bolted down until the coupling has been correctly installed.

6. Fix the axial piston unit at the installation location.
7. Align the drive shaft of the axial piston unit and the output shaft of the diesel engine so that there is no angular deviation.
8. Make sure that no impermissible axial and radial forces act on the drive shaft.
9. For bell housing installation, check the coupling axial play through the bell window according to the manufacturer's instructions.
10. Details on the required tools and tightening torques for the mounting bolts are available from the machine/system manufacturer.
11. When using flexible couplings, check that the drive is free of resonance after completing the installation.

7.4.5 Installation on a gearbox

The installation layout for the axial piston unit on a gearbox is described below.

After installing on a gearbox, the axial piston unit is covered and is difficult to access:

- ▶ Therefore, before installing, make sure that the spigot diameter centers the axial piston unit (observe tolerances) and that no impermissible axial or radial forces act on the drive shaft of the axial piston unit (installation length).
- ▶ Protect the drive shaft against frictional corrosion by providing permanent lubrication.
- ▶ Fix the axial piston unit at the installation location.

For attachment via gear wheel or helically-toothed shaft

No gearing forces higher than the permissible axial and radial forces are to act on the shaft, if necessary the gear wheel must be supported separately at the gearbox output.

7.4.6 Installation with cardan shaft

To connect the axial piston unit to the diesel engine via a cardan shaft:

1. Position the axial piston unit close to the specified installation location.
It should allow enough space for the cardan shaft to fit through on both sides.
2. Position the cardan shaft on the output shaft of the diesel engine.
3. Push the axial piston unit to the cardan shaft and join the cardan shaft to the drive shaft of the axial piston unit.
4. Bring the axial piston unit to the installation position and secure. If necessary, details on the required tools and tightening torques for the mounting bolts can be obtained from the system manufacturer.

7.4.7 Completing installation

1. Remove any mounted transport screws.

CAUTION! Operation with protection plug!

Operating the axial piston unit with protection plugs may result in injuries or damage to the axial piston unit.

- ▶ Before commissioning, remove all protection plugs and replace them with suitable, pressure-proof, metal threaded plugs.
2. Remove the transport protection.
The axial piston unit is delivered with protection plugs **(1)** and protection covers **(2)**. They are not pressure-resistant, therefore they have to be removed prior to connection. Use a suitable tool for this to prevent damage to the sealing and functional surfaces. If sealing or functional surfaces are damaged, contact your responsible Bosch Rexroth Service partner or the service department of the manufacturer's plant for the axial piston unit.

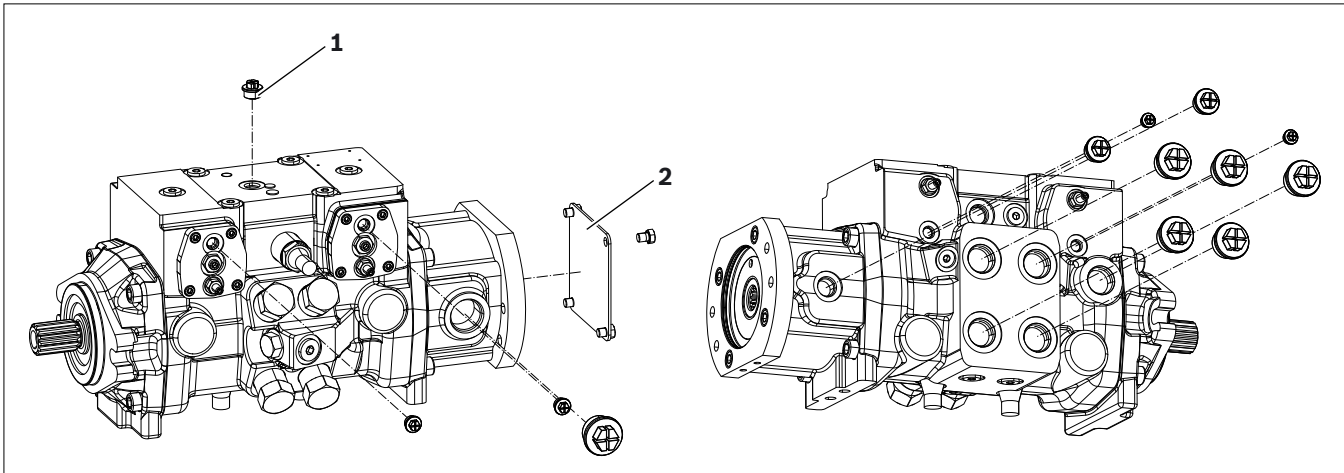

Fig. 12: Removing transport protection

1 Protection plug/threaded plug

2 Protection cover



Ports intended for connecting lines are covered by protection plugs or threaded plugs, which serve as transport protection. All ports required for functional operation must be connected (see Table 10 “Ports A22VG series 40 series 40” on page 36). If this requirement is disregarded, malfunction or damage may result. If a port is not connected, it must be plugged with a threaded plug because protection plugs are not pressure-resistant.



The setting screws are protected against unauthorized resetting by means of protection caps. Removing the protection caps will void the warranty. If you need to change settings, contact your responsible Bosch Rexroth Service partner (for address, see chapter 10.5 “Spare parts” on page 45).

- 3.** For versions with through drive, install the auxiliary pump according to the pump manufacturer’s instructions.

7.4.8 Hydraulically connecting the axial piston unit

NOTE

Insufficient suction pressure!

Generally, a minimum permissible suction pressure at port “S” is specified for axial piston pumps with boost pump in all installation positions. If the pressure at port “S” drops below the specified values, damage may occur which may lead to the axial piston pump being damaged beyond repair!

- ▶ Make sure that the necessary suction pressure is not undercut. This is influenced by:
 - the piping (e.g. suction cross-section, pipe diameter, length of suction line)
 - the position of the reservoir
 - the viscosity of the hydraulic fluid
 - if fitted, a filter cartridge or check valve in the suction line (regularly check the level of soiling of the filter cartridge)

The machine/system manufacturer is responsible for dimensioning the lines. The axial piston unit must be connected to the rest of the hydraulic system in accordance with the hydraulic schematic of the machine/system manufacturer.

The ports and fastening thread are designed for the maximum pressure specified in the data sheet. The machine/system manufacturer must ensure that the connecting elements and lines correspond to the specified application conditions (pressure, flow, hydraulic fluid, temperature) with the necessary safety factors.



Connect only hydraulic lines that are appropriate for the axial piston unit port (pressure level, size, system of units).

Notes on routing the lines

Observe the following notes when routing the suction, pressure and reservoir lines.

- Lines and hoses must be installed without pre-charge pressure, so that no further mechanical forces are applied during operation that will reduce the service life of the axial piston unit and, if applicable, the entire machine/system.
- Use suitable seals as sealing material.
- Suction line (pipe or hose)
 - The suction line should be as short and straight as possible.
 - Measure the line cross section of the suction line so that the pressure at the suction port does not drop below the minimum permissible pressure. Make sure that the maximum suction pressure is not exceeded (e.g. when pre-filling).
 - Make sure the connections and connecting elements are air-tight.
 - The hose must be pressure-resistant, also for external air pressure.
- Pressure line
 - For the pressure lines, use only pipes, hoses and connecting elements rated for the operating pressure range specified in data sheet 93221 (see Table 10).

- Drain line
 - Always route the reservoir lines so that the case is constantly filled with hydraulic fluid and to ensure that no air gets through the shaft seal even during extended standstill periods.
 - The case pressure must not exceed the limit values listed for the axial piston unit in the data sheet under any operating conditions.
 - The reservoir line joint in the reservoir must always be below the minimum fluid level under all conditions (see chapter 7.3 “Installation position” on page 26).
- If the axial piston unit is equipped with installed screw fittings, these must not be unscrewed. Screw the threaded plug of the fitting directly into the installed screw fitting.

Risk of mix-ups with threaded connections

Axial piston units are employed in regions using the metric measuring system, in regions using the Anglo-American (imperial) measuring system and in regions using the Japanese measuring system (JIS – **J**apan **I**ndustrial **S**tandard). Moreover, various kinds of seal are used.

The system of units, the kind of seal and the size of female thread and threaded plugs (e.g. locking screw) must all match.

Due to the limited options for visually detecting differences, there is a risk of mix-ups.

WARNING! Leaky or popped-out threaded plugs!

If a threaded plug which is of a different measurement system, kind of seal and size with respect to the female thread is pressurized, the threaded plug may loosen itself or even be ejected from the hole in a projectile-like manner. This can result in serious injury and damage to equipment. Hydraulic fluid can be discharged from this leakage point.

- ▶ Use the drawings (installation drawing) to determine the required threaded plug for each fitting.
- ▶ Make certain that there are no mix-ups when installing fittings, mounting bolts and threaded plugs.
- ▶ For all female threads, use a threaded plug from the same system of units and of the correct size.

Port overview

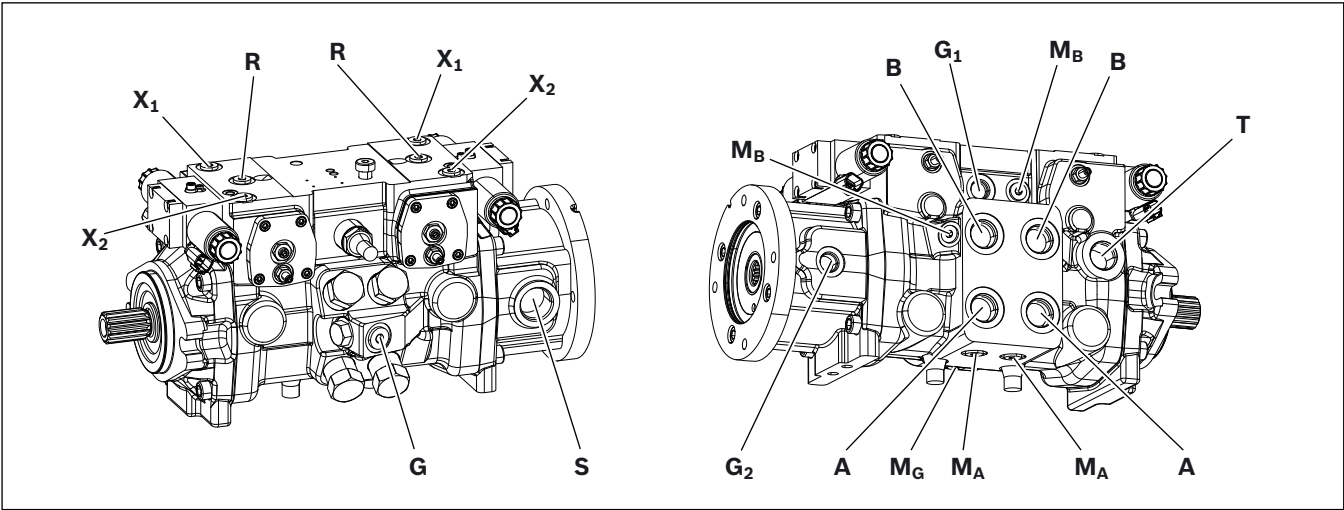

Fig. 13: Port overview A22VG, EP control with boost pump

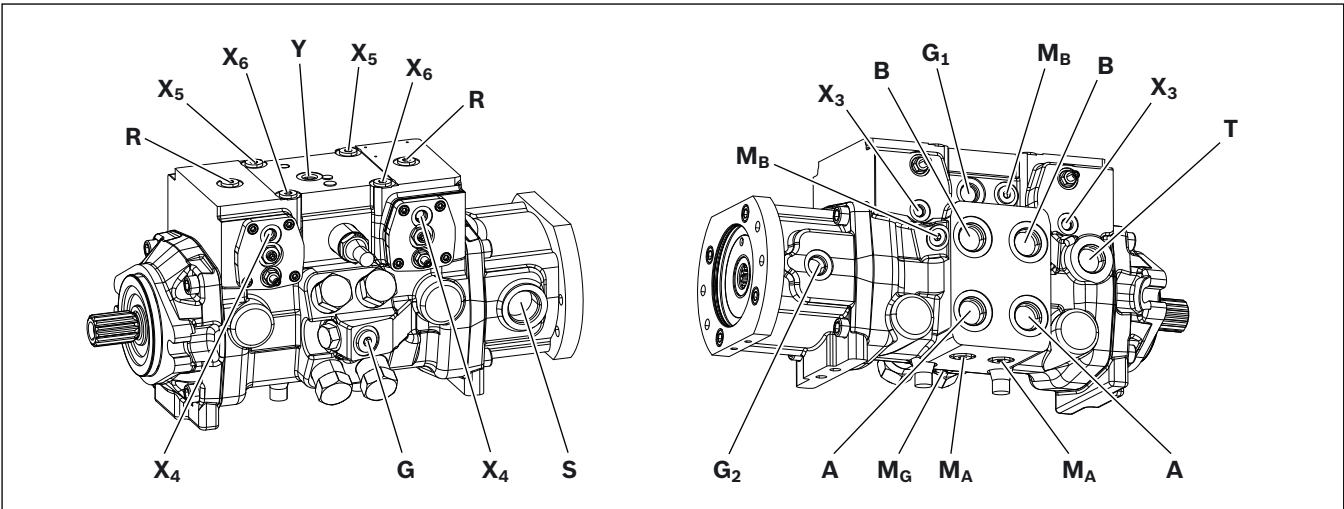

Fig. 14: Port overview A22VG, HT control with boost pump

Table 10: Ports A22VG series 40¹⁾

Ports		p_{\max} [bar] ²⁾	State
A, B	Service line port	420	O
S	Suction port (only with boost pump)	5	O
T	Drain port	3	O
R	Air bleed	3	X
X ₁ , X ₂	Control pressure (upstream of orifice, only HP, HW, EP and ET)	30	X
X ₃ , X ₄ ³⁾	Stroking chamber pressure	30	X
X ₅ , X ₆	Control pressure (upstream of orifice, HT only)	30	O
Y	Pilot pressure, outlet (only with DA control valve)	30	O
G	Boost pressure, inlet	30	O
G ₁	Boost pressure, inlet (only with DA control valve)	30	O
G ₂	Boost pressure, outlet (only with boost pump)	30	O
M _G	Boost pressure measurement G	30	X
M _A , M _B	Measuring pressure A, B	420	X

¹⁾ The measuring system and thread size can be taken from the installation drawing.

²⁾ Short-term pressure spikes may occur depending on the application. Keep this in mind when selecting measuring devices and fittings.

³⁾ Optional

O = Must be connected (plugged on delivery)

X = Plugged (in normal operation)



Port **G** (or **G₁** on the version with DA control valve) must be charged with boost pressure by the customer.

Tightening torques

The following tightening torques apply:

- Female threads hole of the axial piston unit:
The maximum permissible tightening torques $M_{G \max}$ are maximum values of the for the female threads and must not be exceeded. Values, see Table 11.
- Fittings:
Observe the manufacturer's instruction regarding tightening torques for the used fittings.
- Mounting bolts:
For mounting bolts with metric ISO thread according to DIN 13 or with thread according to ASME B1.1, we recommend checking the tightening torque in individual cases as per VDI 2230.
- Threaded plugs:
For the metallic threaded plugs supplied with the axial piston unit, the required tightening torques of threaded plugs M_v apply. Values, see Table 11.

Table 11: Tightening torques of the female threads and threaded plugs

Ports Standard	Thread size	Maximum permissible tightening torque of the female threads $M_{G\max}$	Required tightening torque of the threaded plugs M_V	WAF hexagon socket of the threaded plugs
ISO 11926	5/16-24 UNF-2B	10 Nm	7 Nm	1/8 in
	3/8-24 UNF-2B	20 Nm	10 Nm	5/32 in
	7/16-20 UNF-2B	40 Nm	18 Nm	3/16 in
	9/16-18 UNF-2B	80 Nm	35 Nm	1/4 in
	3/4-16 UNF-2B	160 Nm	70 Nm	5/16 in
	7/8-14 UNF-2B	240 Nm	110 Nm	3/8 in
	1 1/16-12 UN-2B	360 Nm	170 Nm	9/16 in
	1 5/16-12 UN-2B	540 Nm	270 Nm	5/8 in
	1 5/8-12 UN-2B	960 Nm	320 Nm	3/4 in
	1 7/8-12 UN-2B	1200 Nm	390 Nm	3/4 in

Procedure

To connect the axial piston unit to the hydraulic system:

1. Remove the protection plugs and threaded plugs at the ports at which the connections are to be made according to the hydraulic schematic.
2. Make sure that the sealing surfaces of the hydraulic ports and functional surfaces are not damaged.
3. Use only clean hydraulic lines or flush them before installation. (Note chapter 7.5 “Performing flushing cycle” on page 38 when you flush out the complete system.)
4. Connect the lines in accordance with the installation drawing and the machine or system schematic. Check whether all ports are connected or plugged with threaded plugs.
5. Tighten the fittings correctly (note tightening torques). Mark all correctly tightened fittings, e.g. with a permanent marker.
6. Check all pipes and hose lines and every combination of connecting pieces, couplings or connecting points with hoses or pipes to ensure they are in condition for safe working.



For relationship between direction of rotation and flow direction, please refer to data sheet 93221.

7.4.9 Electrically connecting the axial piston unit

NOTE

Short circuit in event of penetrating hydraulic fluid!

Fluid can penetrate the product and cause a short circuit!

- ▶ Do not install axial piston units with electric components (e.g. electric controls, sensors) in a reservoir below the fluid level (inside-reservoir installation).

The machine/system manufacturer is responsible for the layout of the electric control.

Electrically controlled axial piston units must be connected in accordance with the electrical circuit diagram for the machine/system.

For axial piston units with electrical control and/or mounted sensors, please comply with the details given in data sheet 93221, e.g.:

- the permissible voltage range
- the permissible current
- correct pin assignment
- the recommended electrical control units

Exact details on the connector, type of protection and matching mating connector can also be found in data sheet 93221. The mating connector is not included in the scope of supply.

1. Switch off power supply to the relevant system component.
2. Electrically connect the axial piston unit (12 or 24V). Before connecting, check that the connector including all seals are intact.

Changing connector orientation

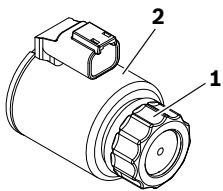

If necessary, you can change the connector orientation by turning the solenoid housing. This is dependent on the connector version.

To do this, proceed as follows:

1. Loosen the mounting nut (1) of the solenoid. To do this, turn the mounting nut (1) one turn counterclockwise.
2. Turn the solenoid body (2) to the desired position.
3. Retighten the mounting nut. Tightening torque of the mounting nut: 5+1 Nm.

7.5 Performing flushing cycle

In order to remove foreign particles from the system, Bosch Rexroth recommends a flushing cycle for the entire system before initial commissioning. To avoid internal contamination, the axial piston unit must not be included in the flushing cycle.



The flushing cycle must be performed with an additional flushing unit. Follow the instructions of the flushing unit's manufacturer for the exact procedure during the flushing cycle.

8 Commissioning

WARNING

Danger while working in the danger zone of a machine/system!

Danger to life, risk of injury or serious injuries!

- ▶ Pay attention to and rectify potential danger sources before operating the axial piston unit.
- ▶ Nobody may stand in the danger zone of the machine/system.
- ▶ The emergency stop button for the machine/system must be within the operator's reach.
- ▶ Always follow the instructions of the machine/system manufacturer during commissioning.

CAUTION

Commissioning of an incorrectly installed product!

Risk of injury and damage to equipment!

- ▶ Make sure that all electrical and hydraulic ports are connected or plugged.
- ▶ Only commission a completely installed fault-free product with original accessories from Bosch Rexroth.

8.1 Initial commissioning



During all work for commissioning the axial piston unit, observe the general safety instructions and intended use detailed in chapter 2 "Safety instructions" on page 8.

- ▶ Connect the gauge for the operating pressure, case pressure and suction pressure to the specified measuring points on the axial piston unit or in the hydraulic system, to check the technical data at first operation.
- ▶ During the commissioning process, monitor the temperature of the hydraulic fluid in the reservoir to ensure that it lies within the permissible viscosity limits.

8.1.1 Filling the axial piston unit

Professional filling and air bleeding is necessary to prevent damage to the axial piston unit and to maintain correct function.



The axial piston unit should be filled with a filling unit (10 µm filter grade). The axial piston unit must not be operated while it is being filled by the filling unit.

Use only a hydraulic fluid that conforms to the following requirements:

Details of minimum requirements for hydraulic fluid can be found in the Bosch Rexroth data sheets 90220, 90221 and 90222. The titles of the data sheets can be found in Table 1 "Required and supplementary documentation" on page 5. You can find details of permissible and optimal viscosity in data sheet 93221.

To ensure the functional reliability of the axial piston unit, cleanliness level 20/18/15 according to at least ISO 4406 is necessary for the hydraulic fluid.



Continuous suction or pressure filtration must be provided by the customer for the boost pressure fluid fed in at port **G** (or **G₁** on the version with DA control valve).

At very high hydraulic fluid temperatures (+90 °C to maximum +115 °C), a cleanliness level of at least 19/17/14 according to ISO 4406 is necessary. For permissible temperatures, see the data sheet 93221.

1. Place a drip tray under the axial piston unit to collect any hydraulic fluid that may escape.

NOTE! Contaminated hydraulic fluid!

The cleanliness levels of hydraulic fluids on delivery do not normally conform to the requirements for our components.

- ▶ Use a suitable filter system to filter hydraulic fluids during filling to minimize solid impurities and water in the hydraulic system.

2. Fill and air bleed the axial piston unit via the appropriate ports, see chapter 7.3 “Installation position” on page 26. The hydraulic lines of the system must also be filled.

NOTE! Damage to equipment due to improper lubrication!

Product can be damaged or destroyed!

- ▶ When using a shut-off valve in the suction and/or reservoir line, make sure that the input of the axial piston unit can only be started when the shut-off valves are open.
3. When using a shut-off valve in the suction and/or reservoir line, only operate the axial piston unit when the shut-off valves are open.
 4. Test the direction of rotation of the diesel engine. To do this, rotate the diesel engine briefly at the lowest rotational speed (inching). Make sure that the direction of rotation of the axial piston unit agrees with the details of the name plate, see chapter 5.3 “Product identification”, Fig. 3: Name plate A22VG on page 19.
 5. Operate the axial piston pump at a lower speed (starter speed for internal combustion engines or inching operation for electric motors) until the hydraulic system is completely filled and air bled. To inspect, drain the hydraulic fluid at the reservoir port and wait until it drains without bubbles.

8.1.2 Testing the hydraulic fluid supply

The axial piston unit must always have a sufficient supply of hydraulic fluid. For this reason, the supply of hydraulic fluid must be ensured at the start of the commissioning process.

When you test the hydraulic fluid supply, constantly monitor the noise development and check the hydraulic fluid level in the reservoir. If the axial piston unit becomes louder (cavitation) or the case drain fluid is discharged with bubbles, this is an indication that the axial piston unit is not being sufficiently supplied with hydraulic fluid.

For information on troubleshooting, see chapter 14 “Troubleshooting” on page 48.

To test the hydraulic fluid supply:

1. Allow the diesel engine to run at the lowest speed. The axial piston unit must be operated without load. Pay attention to leakage and noise.
2. Check the axial piston unit’s reservoir line during the test. The case drain fluid should not contain any bubbles.
3. Increase the load and check whether the operating pressure rises as expected.
4. Carry out a leak test to ensure that the hydraulic system is sealed and can withstand the maximum pressure.
5. Check the suction pressure at port “**S**” of the axial piston pump at nominal speed and maximum swivel angle (only on the version with boost pump). Refer to data sheet 93221 for the permissible value.
6. At maximum pressure, check the case drain pressure at port **T**. Refer to data sheet 93221 for the permissible value.

8.1.3 Performing functional test

WARNING

Incorrectly connected axial piston unit!

Mixing up the ports will lead to malfunctions (e.g. lift instead of lower) and thus to corresponding danger to persons and equipment!

- ▶ Before the functional test, check whether the piping specified in the hydraulic schematic has been installed.

Once you have tested the hydraulic fluid supply, you must perform a functional test on the machine/system. The functional test should be performed according to the instructions of the machine/system manufacturer.

The axial piston unit is checked for functional capability before delivery according to the technical data. During commissioning, it must be ensured that the axial piston unit was installed properly in the machine/system.

- ▶ After starting the diesel engine, check in particular the specified pressures, e.g. system pressure, boost pressure and case pressure.
- ▶ If necessary, remove the pressure gauge and plug the ports with threaded plugs.

8.2 Running-in phase

NOTE

Damage to equipment by insufficient viscosity!

An increased hydraulic fluid temperature may reduce the viscosity values by too much and damage the product!

- ▶ Monitor the operating temperature during the running-in phase, e.g. by measuring the case drain temperature.
- ▶ Reduce the loading (pressure, rpm) of the axial piston unit if impermissible operating temperatures and/or viscosities occur.
- ▶ Operating temperatures that are too high indicate faults that have to be analyzed and cleared.

The bearings and sliding surfaces are subject to a running-in phase. The increased friction at the start of the running-in phase results in increased heat development which decreases with increasing operating hours. The volumetric and mechanical-hydraulic efficiency increases as well through the conclusion of the running-in phase of approx. 10 operating hours.

To ensure that contamination in the hydraulic system does not damage the axial piston unit, Bosch Rexroth recommends the following procedure after the running-in phase:

- ▶ After the running-in phase, have a hydraulic fluid specimen analyzed for the required cleanliness level.
- ▶ Change the hydraulic fluid if the required cleanliness level is not reached. If a laboratory test is not carried out after the running-in phase, Bosch Rexroth recommends the hydraulic fluid be changed.

8.3 Recommissioning after standstill

Depending on the installation conditions and ambient conditions, changes may occur in the hydraulic system which make recommissioning necessary.

Among others, the following criteria may make recommissioning necessary:

- Air and/or water in the hydraulic system
 - Old hydraulic fluid
 - Other contamination
- ▶ Before recommissioning, proceed as described in chapter 8.1 “Initial commissioning” on page 39.

9 Operation

The product is a component which requires no settings or changes during operation. For this reason, this chapter of the manual does not contain any information on adjustment options. Use the product only within the performance range provided in the technical data. The machine/system manufacturer is responsible for the proper project planning of the hydraulic system and its control.

10 Maintenance and repair

NOTE

Inspection and maintenance work carried out too late!

Damage to equipment!

- ▶ Carry out the specified inspection and maintenance work at the intervals described in this manual.

10.1 Cleaning and care

NOTE

Damage to seals and electrical system by mechanical effects!

The water jet of a high-pressure cleaner may damage the seals and electrical system of the axial piston unit!

- ▶ Do not point the high-pressure cleaner at sensitive components, e.g. shaft seal, electrical connections and components.

For cleaning and care of the axial piston unit, observe the following:

- ▶ Check whether all seals and fittings on the connections are securely seated to ensure that no moisture can penetrate into the axial piston unit during cleaning.
- ▶ Use only water and, if necessary, a mild detergent to clean the axial piston unit. Never use solvents or aggressive detergents.
- ▶ Remove external coarse dirt and keep sensitive and important components, such as solenoids, valves and sensors, clean.

10.2 Inspection

In order to enable long and reliable operation of the axial piston unit, Bosch Rexroth recommends testing the hydraulic system and axial piston unit on a regular basis, and documenting and archiving the following operating conditions:

Table 12: Inspection schedule

Task to be carried out		Interval
Hydraulic system	Check level of hydraulic fluid in the reservoir.	Daily
	Check the operating temperature at a comparable load condition at the reservoir port and in the reservoir.	Weekly
	Conduct analysis of hydraulic fluid: viscosity, aging and dirt contamination	Yearly or every 2000 operating hours (whichever occurs first)
Axial piston unit	Check axial piston unit for leakage. Early detection of hydraulic fluid loss can help to find faults on the machine/system and to rectify them. For this reason, Bosch Rexroth recommends that the axial piston unit and system are always kept in a clean condition.	Daily
	Check axial piston unit for unusual noise development.	Daily
	Check fastener elements for tight seating. All fasteners have to be checked when the hydraulic system is switched off, depressurized and cooled down.	Monthly

10.3 Maintenance

The axial piston unit is low maintenance when used properly.

The service life of the axial piston unit is heavily dependent on the quality of the hydraulic fluid. For this reason, we recommend changing the hydraulic fluid at least once per year or every 2000 operating hours (which ever occurs first) or having it analyzed by the hydraulic fluid manufacturer or a laboratory to determine its suitability for further use.

The service life of the axial piston unit is limited by the service life of the bearings fitted. The service life can be requested from the responsible Bosch Rexroth Service partner, see chapter 10.5 "Spare parts" on page 45. Based on these details, a maintenance interval is to be determined by the system manufacturer for the replacement of the bearings and included in the maintenance schedule of the hydraulic system.

10.4 Repair

Bosch Rexroth offers a comprehensive range of services for the repair of Rexroth axial piston units.

Repairs on the axial piston unit and its fittings may only be performed by service centers certified by Bosch Rexroth.

- ▶ Use exclusively original spare parts from Rexroth to repair the Rexroth axial piston units, otherwise the functional reliability of the axial piston unit can not be assured and you lose your entitlement under warranty.

In the event of questions regarding repairs, contact your responsible Bosch Rexroth Service partner or the service department of the manufacture's plant for the axial piston unit, see chapter 10.5 "Spare parts" on page 45.

10.5 Spare parts

CAUTION

Use of unsuitable spare parts!

Spare parts that do not meet the technical requirements specified by Bosch Rexroth may cause personal injury or property damage!

- ▶ Only use Rexroth original spare parts to repair the Rexroth axial piston units, otherwise the functional reliability of the axial piston unit can not be assured and you lose your entitlement under warranty.

The spare parts lists for axial piston units are order specific. When ordering spare parts, quote the material and serial number of the axial piston unit as well as the material numbers of the spare parts.

Address all questions regarding spare parts to your responsible Bosch Rexroth Service partner or the service department of the manufacturer's plant for the axial piston unit.

Bosch Rexroth AG
 Glockeraustraße 4
 89275 Elchingen, Germany
 Hotline +49-9352-405060
 spares.elchingen@boschrexroth.de

Spare parts can be found in the internet at www.boschrexroth.com/spc

For general inquiries, please contact svm.support@boschrexroth.de

For the addresses of foreign subsidiaries, please refer to www.boschrexroth.com/addresses

11 Removal and replacement

11.1 Required tools

Removal can be performed with standard tools. No special tools are necessary.

11.2 Preparing for removal

1. Decommission the entire system as described in the instruction manual for the machine or system.
 - Relieve pressure in the hydraulic system according to the instructions of the machine or system manufacturer.
 - Make sure that the relevant system components are not under pressure or voltage.
2. Protect the complete system against being energized.

11.3 Removal of the axial piston unit

Proceed as follows to remove the axial piston unit:

1. Check whether the hydraulic system is depressurized.
2. Allow the axial piston unit to cool down until it can be removed without danger.
3. For below-reservoir installation, before removing the axial piston unit from the complete system, seal the connection to the reservoir or drain the reservoir.
4. Place a drip tray under the axial piston unit to collect any hydraulic fluid that may escape.
5. Loosen the lines and collect the escaping hydraulic fluid in the drip tray.
6. Remove the axial piston unit. Use a suitable lifting device.
7. Completely empty the axial piston unit.
8. Plug all openings.

11.4 Preparing the components for storage or further use

- ▶ Proceed as described in chapter 6.2 “Storing the axial piston unit” on page 22.

12 Disposal

Careless disposal of the axial piston unit, the hydraulic fluid and the packaging material could lead to pollution of the environment.

Observe the following points when disposing of the axial piston unit:

1. Completely empty the axial piston unit.
2. Dispose of the axial piston unit and packaging material in accordance with the national regulations in your country.
3. Dispose of the hydraulic fluid according to the national regulations of your country. Also observe the applicable safety data sheet for the hydraulic fluid.
4. Remove the axial piston unit into its individual parts and properly recycle these parts.
5. Separate according to, for instance:
 - Castings
 - Steel
 - Aluminum
 - Non-ferrous metal
 - Electronic waste
 - Plastic
 - Seals

13 Extension and conversion

Do not modify the axial piston unit or its fittings. This includes changes to the setting screws or wiring.



The Bosch Rexroth warranty only applies for the delivered configuration. In case of conversion or extension, the entitlement under warranty will be rendered void.



The setting screws are protected against unauthorized resetting by means of protection caps. Removing the protection caps will void the warranty. If you need to change settings, contact your responsible Bosch Rexroth Service partner (for address, see chapter 10.5 “Spare parts” on page 45).

14 Troubleshooting

Table 13 and may help you when troubleshooting. The Table makes no claim for completeness.

In practical use, problems which are not listed here may also occur.

14.1 How to proceed for troubleshooting

- ▶ Always act systematically and purposefully, even under pressure of time. Random and imprudent removal and changing of settings could result in the inability to ascertain the original failure cause.
- ▶ First obtain a general overview of how your product works in conjunction with the entire system.
- ▶ Try to find out whether the product has worked properly in conjunction with the entire system before the fault occurred.
- ▶ Try to determine any changes of the entire system in which the product is integrated
 - Were there any changes to the product's application conditions or operating range?
 - Has maintenance work recently been carried out? Is there an inspection or maintenance log?
 - Were changes (e.g. conversions) or repairs made to the complete system (machine/system, electrics, control) or on the product? If yes, which?
 - Has the hydraulic fluid been changed?
 - Was the product or machine operated as intended?
 - How did the malfunction appear?
- ▶ Try to get a clear idea of the error cause. Directly ask the (machine) operator.
- ▶ Document the work carried out.
- ▶ If you cannot rectify the error, contact one of the contact addresses which can be found at:
www.boschrexroth.com/addresses.

14.2 Malfunction table

Table 13: Axial piston unit malfunction table

Malfunction	Possible cause	Remedy	
Unusual noises	Drive speed too high.	Machine/system manufacturer.	
	Wrong direction of rotation.	Ensure correct direction of rotation.	
	Insufficient suction conditions, e.g. air in the suction line, insufficient diameter of the suction line, viscosity of the hydraulic fluid too high, suction height too high, suction pressure too low, contaminants in the suction line (only relevant for the version with boost pump).		Machine or system manufacturer (e.g. optimize inlet conditions, use suitable hydraulic fluid).
			Completely air bleed axial piston unit, fill suction line with hydraulic fluid.
			Remove contaminants from the suction line.
	Improper mounting of the axial piston unit.	Check the mounting of the axial piston unit according to the specifications of the machine/system manufacturer. Observe tightening torques.	
	Improper mounting of the attachment parts, e.g. coupling and hydraulic lines.	Fix attachment parts according to the information provided by the coupling or fitting manufacturer.	
	Pressure-relief valves on axial piston unit.	Air bleed the axial piston unit Check viscosity of the hydraulic fluid Contact Bosch Rexroth Service.	
Pressure-relief valve of the axial piston unit (boost pressure, high pressure).	Air bleed the axial piston unit Check viscosity of the hydraulic fluid Contact Bosch Rexroth Service.		
Mechanical damage to the axial piston unit (e.g. bearing damage).	Exchange axial piston unit, contact Bosch Rexroth Service.		
No or insufficient flow	Faulty mechanical drive (e.g. defective coupling).	Machine/system manufacturer.	
	Drive speed too low.	Machine/system manufacturer.	
	Insufficient suction conditions, e.g. air in the suction line, insufficient diameter of the suction line, viscosity of the hydraulic fluid too high, suction height too high, suction pressure too low, contaminants in the suction line (only relevant for the version with boost pump).		Machine or system manufacturer (e.g. optimize inlet conditions, use suitable hydraulic fluid).
			Completely air bleed axial piston unit, fill suction line with hydraulic fluid.
			Remove contaminants from the suction line.
	Hydraulic fluid not in optimum viscosity range.	Use suitable hydraulic fluid (machine/system manufacturer).	
	External control of the control device defective.	Check external control (machine/system manufacturer).	
	Insufficient pilot pressure or control pressure.	Check pilot pressure or control pressure, contact Bosch Rexroth Service.	
	Malfunction of the control device or controller of the axial piston unit.	Contact Bosch Rexroth Service.	
Wear of axial piston unit.	Exchange axial piston unit, contact Bosch Rexroth Service.		
Mechanical damage to the axial piston unit.	Exchange axial piston unit, contact Bosch Rexroth Service.		

Table 13: Axial piston unit malfunction table

Malfunction	Possible cause	Remedy	
No or insufficient pressure	Faulty mechanical drive (e.g. defective coupling).	Machine/system manufacturer.	
	Drive power too low.	Machine/system manufacturer.	
	Insufficient suction conditions, e.g. air in the suction line, insufficient diameter of the suction line, viscosity of the hydraulic fluid too high, suction height too high, suction pressure too low, contaminants in the suction line (only relevant for the version with boost pump).		Machine or system manufacturer (e.g. optimize inlet conditions, use suitable hydraulic fluid).
			Completely air bleed axial piston unit, fill suction line with hydraulic fluid.
			Remove contaminants from the suction line.
	Hydraulic fluid not in optimum viscosity range.	Use suitable hydraulic fluid (machine/system manufacturer).	
	External control of the control device defective.	Check external control (machine/system manufacturer).	
	Insufficient pilot pressure or control pressure.	Check pilot pressure or control pressure, contact Bosch Rexroth Service.	
	Malfunction of the control device or controller of the axial piston unit.	Contact Bosch Rexroth Service.	
	Wear of axial piston unit.	Exchange axial piston unit, contact Bosch Rexroth Service.	
Mechanical damage to the axial piston unit (e.g. bearing damage).	Exchange axial piston unit, contact Bosch Rexroth Service.		
Output unit defective (e.g. hydraulic motor or cylinder).	Machine/system manufacturer.		
Pressure/flow fluctuations	Axial piston unit not or insufficiently air bled.	Completely air bleed axial piston unit.	
	Insufficient suction conditions, e.g. air in the suction line, insufficient diameter of the suction line, viscosity of the hydraulic fluid too high, suction height too high, suction pressure too low, contaminants in the suction line (only relevant for the version with boost pump).	Machine or system manufacturer (e.g. optimize inlet conditions, use suitable hydraulic fluid).	
		Completely air bleed axial piston unit, fill suction line with hydraulic fluid. Remove contaminants from the suction line.	
Excessive hydraulic fluid temperature and case temperature	Excessive inlet temperature at the axial piston unit.	Machine or system manufacturer: inspect system, e.g malfunction of the cooler, insufficient hydraulic fluid in the reservoir.	
	Malfunction of the pressure control valves (e.g. high-pressure relief valve, pressure controller).	Contact Bosch Rexroth Service.	
	Wear of axial piston unit.	Exchange axial piston unit, contact Bosch Rexroth Service.	
Instability/vibrations	Setpoint value not stable.	Machine/system manufacturer.	
	Resonance in the reservoir line.	Machine/system manufacturer.	
	Malfunction of the control devices or the controller.	Contact Bosch Rexroth Service.	

15 Technical data

The permissible values of the technical data of your axial piston unit can be found in data sheet 93221.

The data sheet can be found on the Internet under
www.boschrexroth.com/various/utilities/mediadirectory/index.jsp?&language=en-GB

Further information can be found in the online product catalog
Mobile Hydraulics: www.boschrexroth.com/axial-piston-pumps

The order-related technical data of your axial piston unit can be found in the order confirmation.

16 Alphabetical index

▶ A		▶ I	
Abbreviations	7	Identification	19
Above-reservoir installation	27	Inspection	44
Assembly	17	Installation	24
		– Completing	31
▶ B		– General instructions	29
Below-reservoir installation	26	– On a gearbox	30
		– Preparation	28
▶ C		– With cardan shaft	31
Care	43	– With coupling	30
Circuit		Installation conditions	24
– closed	17	Installation position	
Cleaning	43	– Above-reservoir installation	27
Commissioning	39	– Below-reservoir installation	26
– Initial	39	Installing	28
Connecting		Intended use	8
– Electrical	38		
– Hydraulic	33	▶ L	
Control	18	Lifting device	20
Conversion	47	Lifting strap	21
Corrosion protection	22		
Corrosion protection film	22	▶ M	
Cylinder	17	Maintenance	43, 44
		Malfunction table	49
▶ D			
Damage to equipment	13	▶ N	
Designations	7	Name plate	19
Dimensions	20, 29	Notes	
Direction of rotation	28	– General	29
Disposal	47		
Drive shaft	17	▶ O	
		Operation	43
▶ E			
Eye bolt	20	▶ P	
		Performance description	17
▶ F		Piston	17
Filling	39	Port overview	35
Flushing cycle	38	Product description	17
Functional description		Pump	18
– Control	18		
Functional test	41	▶ Q	
		Qualifications	9

► R	
Recommissioning	
– after standstill	42
Removal	46
– Performing	46
– Preparing	46
Repair	45
Replacement	46
Required documentation	5
Retainer plate	17
Running-in phase	42
► S	
Safety instructions	8
– General	9
– Product-specific	10
– Signal word	6
Scope of supply	16
Slipper pad	17
Solenoid position	
– Changing	38
Spare parts	45
Storage	20
Storage time	22
Storing	22
Stroking piston	17
Swashplate	17
Symbols	6
► T	
Technical data	51
Tightening torques	36
Tools	46
Transport	20
– By hand	20
– With eye bolt	20
– With lifting strap	21
Transporting	20
Transport protection	32
Troubleshooting	48
► U	
Unpacking	24
► W	
Warranty	15, 32, 47
Weight	20

Bosch Rexroth AG

Mobile Applications
Glockeraustraße 4
89275 Elchingen
Germany
Tel.: +49-7308-82-0
info.ma@boschrexroth.de
www.boschrexroth.com

Your local contact can be found at:

www.boschrexroth.com/addresses