

Axial piston variable double pump

A21VG series 20



- ▶ Size 35, 45
- ▶ Nominal pressure 420 bar
- ▶ Maximum pressure 450 bar
- ▶ Closed circuit

Features

- ▶ Variable double pump with two axial piston rotary groups of swashplate design for hydrostatic drives in a closed circuit
- ▶ The flow is proportional to the drive speed and displacement
- ▶ The flow can be infinitely varied by adjusting the swashplate angle.
- ▶ Flow direction changes smoothly when the swashplate is moved through the neutral position.
- ▶ Only one shared port for case drain fluid for both circuits
- ▶ Compact design for tight installation conditions

Contents

Ordering code	2
Hydraulic fluid	4
Shaft seal	5
Operating pressure range	6
Technical data	7
EP – Proportional control electric	9
HT – Hydraulic control, direct operated	11
HW – Proportional control hydraulic, mechanical servo	12
ET – Electric control, direct operated	14
eEP – Proportional Control Operation with electronic feedback	15
Dimensions	16
Through drive dimensions	20
Overview of attachment options	20
High-pressure relief valves	21
Mechanical stroke limiter	22
Pilot shut-off valve (Neutral valve)	23
DA – Control valve, fixed setting	25
Swivel angle sensor	27
Connector for solenoids	28
Installation dimensions for coupling assembly	28
Installation instructions	29
Project planning notes	31
Safety instructions	32

Ordering code

01	02	03	04	05	06	07	08	/	09	10	11	12	13	14	15	16	-	17
A21V	G								20	A		N	B2					

Axial piston unit

01	Variable swashplate design	A21V
----	----------------------------	------

Operating mode

02	Pump in closed circuit	G
----	------------------------	---

Size (NG)

03	Displacement	35	45
----	--------------	----	----

Control device

		35	45	
04	Hydraulic control direct operated – optimized for hydraulic control	●	●	HT1
	Proportional electric control, mechanical feedback – 12 V DC	●	●	EP1
	Proportional electric control, mechanical feedback – 24 V DC	●	●	EP2
	Proportional electric control, direct operated, two pressure reducing valves – 12 V DC eEP proportional control operation with electronic feedback, see Page 15	●	●	ET1
	Proportional electric control, direct operated, two pressure reducing valves – 24 V DC eEP proportional control operation with electronic feedback, see Page 15	●	●	ET2
	Proportional hydraulic control with mechanical servo, hexagon shaft with lever, free position	●	●	HW1
	Proportional hydraulic control with mechanical servo, hexagon shaft with lever, free position including neutral switch	●	●	HW8

Connector for solenoids

		35	45	
05	Without connector (without solenoid, only for hydraulic control)	●	●	0
	DEUTSCH molded connector, 2-pin – without suppressor diode	●	●	P

Swivel angle sensor

		35	45	
06	Without swivel angle sensor	●	●	0
	Electric swivel angle sensor mounted – mandatory for eEP operation (see page Page 15)	●	●	D

Mechanical stroke limiter

07	Without mechanical stroke limiter	0
	With mechanical stroke limiter	M

Valve options

		35	45	
08	Without pilot shut-off valve or DA valve	●	●	0
	DA control valve fixed setting (not possible with pilot shut off)	●	●	1
	Pilot shut-off valve – 12 V DC	●	●	3
	Pilot shut-off valve – 24 V DC	●	●	4

Series

09	Series 2, index 0	20
----	-------------------	----

Configuration

10	ANSI, port threads with O-ring seal according to ISO 11926	A
----	--	---

Direction of rotation

11	Viewed on drive shaft	clockwise	R
		counter-clockwise	L

● = Available options ○ = On request

01	02	03	04	05	06	07	08		09	10	11	12	13	14	15	16	17	
A21V	G							/	20	A		N	B2				-	

Seals

12	NBR (nitrile-caoutchouc), shaft seal in FKM (fluoro-caoutchouc)	N
----	---	----------

Mounting flange

13	SAE J744 101-2	B2
----	----------------	-----------

Drive shaft

		35	45	
14	Splined shaft ANSI B92.1a-1976 (1 in 15T 16/32DP)	●	●	S5
	Splined shaft ANSI B92.1a-1976 (1¼ in 14T 12/24DP)	●	●	S7

Service line ports

		35	45	
15	Threaded ports A and B, left (viewed on drive shaft)	●	●	3
	Threaded ports A and B, right (viewed on drive shaft) – consult factory	○	○	4

Through drive

		35	45	
16	Without through drive	●	●	0000
	Flange SAE J744			
	Diameter	Mounting	Code	Hub for splined shaft Diameter
			Code	
	82-2 (A)	○-○	A2	5/8 in 9T 16/32DP S2
		○-○	A2	3/4 in 11T 16/32DP S3
		○-○	A2	7/8 in 13T 16/32DP S4
	101-2 (B)	○-○	B2	7/8 in 13T 16/32DP S4
			B2	1 in 15T 16/32DP S5

Standard / special version

17	Standard version	0
	Standard version with installation variant, e.g. "T" plugged vs open	Y
	Special version, e.g. 35cc displacement 2 nd pump, different controller 2 nd pump, etc.	S

● = Available options ○ = On request

Hydraulic fluid

The axial piston unit is designed for operation with HLP mineral oil according to DIN 51524. Application instructions and requirements for hydraulic fluid selection, behavior during operation as well as disposal and environmental protection should be taken from the following data sheets before the start of project planning:

- ▶ 90220: Hydraulic fluids based on mineral oils and related hydrocarbons
- ▶ 90221: Environmentally acceptable hydraulic fluids
- ▶ 90222: Fire-resistant, water-free hydraulic fluids (HFDR/HFDU)
- ▶ 90225: Limited technical data for operation with water-free and water-containing fire-resistant hydraulic fluids (HFDR, HFDU, HFAE, HFAS, HFB, HFC)

Notes on selection of hydraulic fluid

The hydraulic fluid should be selected so that the operating viscosity in the operating temperature range is within the optimum range (v_{opt} see selection diagram).

Viscosity and temperature of hydraulic fluids

	Viscosity [SUS (mm ² /s)]	Shaft seal	Temperature ³⁾	Comment
Cold start	$v_{max} \leq 7400$ (1600)	NBR ²⁾	$\theta_{St} \geq -40$ °F (-40 °C)	$t \leq 3$ min, without load ($p \leq 725$ psi (50 bar), $n \leq 1000$ rpm) Permissible temperature difference between axial piston unit and hydraulic fluid in the system maximum 45 °F (25 K).
		FKM	$\theta_{St} \geq -13$ °F (-25 °C)	
Warm-up phase	$v = 7400 \dots 1850$ (1600 ... 400)			$t \leq 15$ min, $p \leq 0.7 \times p_{nom}$ and $n \leq 0.5 \times n_{nom}$
Continuous operation	$v = 1850 \dots 60$ ¹⁾ (400 ... 10)	NBR ²⁾	$\theta \leq +185$ °F (+85 °C)	measured at port T
		FKM	$\theta \leq +230$ °F (+110 °C)	
	$v_{opt} = 170 \dots 82$ (36 ... 16)			Range of optimum operating viscosity and efficiency
Short-term operation	$v_{min} = 60 \dots 49$ (10 ... 7)	NBR ²⁾	$\theta \leq +185$ °F (+85 °C)	$t \leq 3$ min, $p \leq 0.3 \times p_{nom}$, measured at port T
		FKM	$\theta \leq +230$ °F (+110 °C)	

▼ Selection diagram

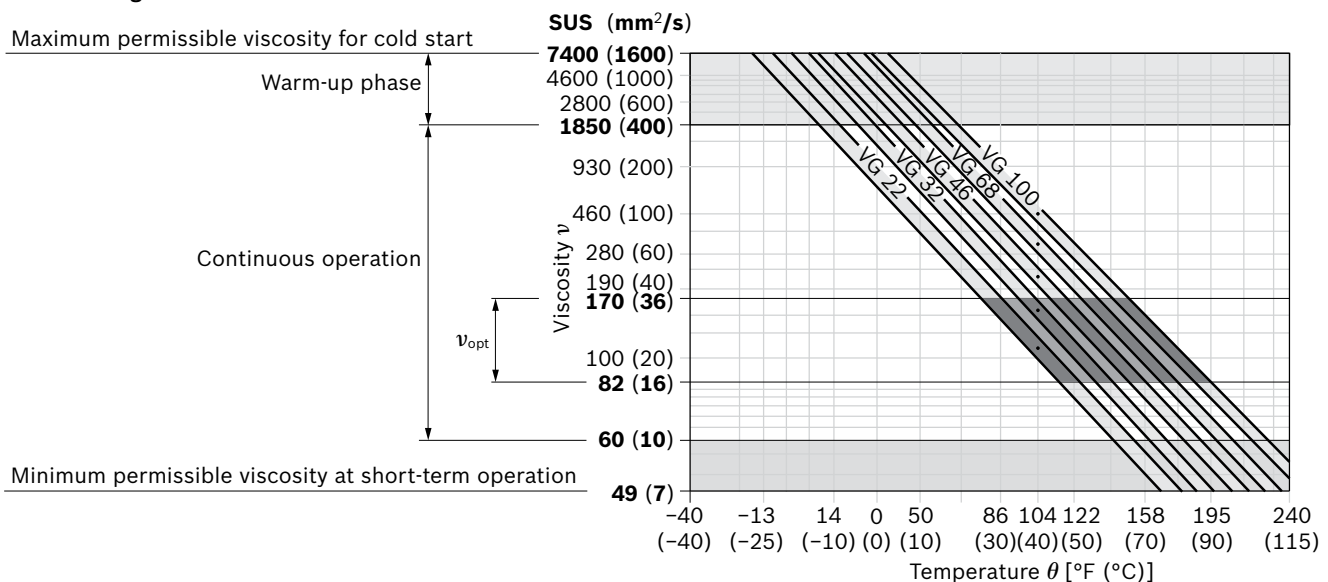

1) Corresponds e.g. for VG 46 to a temperature range of +39 °F (+4 °C) to +185 °F (+85 °C) (see selection diagram)

2) Special version, please contact us

3) If the temperature at extreme operating parameters cannot be adhered to, please contact us.

Filtration of the hydraulic fluid

Finer filtration improves the cleanliness level of the hydraulic fluid, which increases the service life of the axial piston unit.

A cleanliness level of at least 20/18/15 is to be maintained according to ISO 4406.

We recommend, depending on the system and application, for the A21VG: filter cartridges $\beta_{20} \geq 100$.

At very high hydraulic fluid temperatures (90 °C to maximum 110 °C, measured at port T), a cleanliness level of at least 19/17/14 according to ISO 4406 is necessary.

Shaft seal

Permissible pressure loading

The service life of the shaft seal is influenced by the speed of the axial piston unit and the leakage pressure in the housing (case pressure). Momentary pressure spikes ($t < 0.1$ s) of up to 10 bar are permitted. The service life of the shaft seal decreases with increasing frequency of pressure spikes and increasing mean differential pressure. The case pressure must be equal to or higher than the ambient pressure.

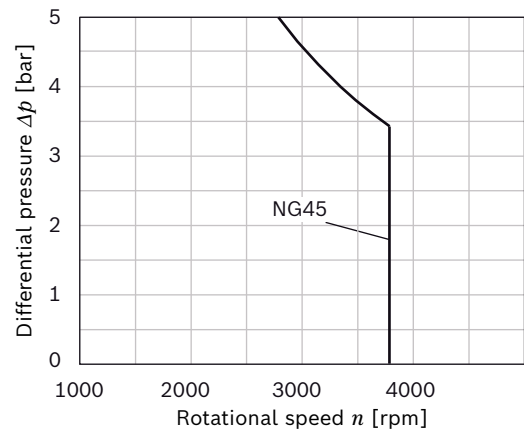

The FKM shaft seal may be used for leakage temperatures from -25 °C to +115 °C. For application cases below -25 °C, an NBR shaft seal is required (permissible temperature range: -40 °C to +90 °C).

Operating pressure range

Pressure at service line port A or B		Definition
Nominal pressure p_{nom}	420 bar	The nominal pressure corresponds to the maximum design pressure.
Maximum pressure p_{max}	450 bar	The maximum pressure corresponds to the maximum operating pressure within the single operating period. The sum of the single operating periods must not exceed the total operating period.
Single operating period	1 s	
Total operating period	50 h	
Minimum pressure (high-pressure side)	25 bar	Minimum pressure at the high-pressure side (A or B) which is required in order to prevent damage to the axial piston unit.
Minimum pressure (low-pressure side)	10 bar above case pressure	Minimum pressure at the low-pressure side (A or B) which is required in order to prevent damage to the axial piston unit. Boost pressure setting must be higher depending on system.
Rate of pressure change $R_{A\ max}$	9000 bar/s	Maximum permissible rate of pressure build-up and reduction during a pressure change over the entire pressure range.
Charge pressure		
Maximum charge pressure G port	30 bar	
Control pressure		
Minimum control pressure $p_{St\ min}$		To ensure the function of the control, a minimum control pressure $p_{St\ min}$ at $n = 2000$ rpm is required depending on the rotational speed and operating pressure.
Controls EP and HW	18 bar above case pressure	
Controls ET and HT	25 bar above case pressure	

▼ Rate of pressure change $R_{A\ max}$

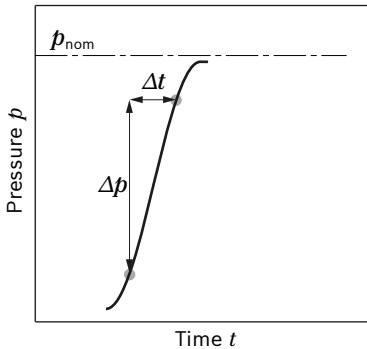

▼ Pressure definition

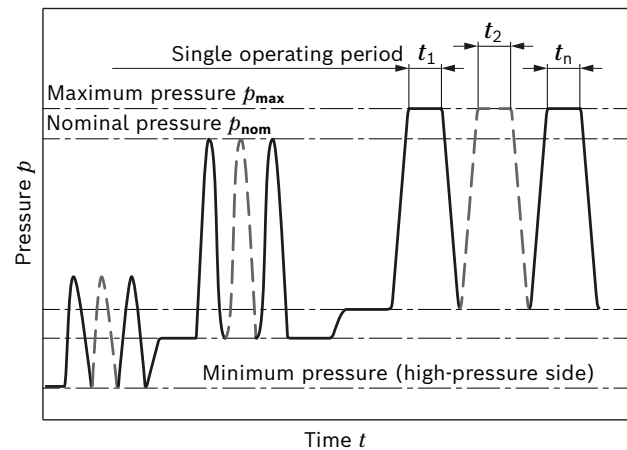

$$\text{Total operating period} = t_1 + t_2 + \dots + t_n$$

Note

Operating pressure range valid when using hydraulic fluids based on mineral oils. Values for other hydraulic fluids, please contact us.

Technical data

Size		NG		35	45	
Displacement geometric, per revolution	variable pump (for each rotary group)	$V_{g \max}$	cm ³	2 x 35	2 x 45	
Rotational speed ¹⁾	maximum at $V_{g \max}$	n_{nom}	rpm	3300	3300	
	limited maximum ²⁾	n_{max1}	rpm	3550	3550	
	intermittent maximum ³⁾	n_{max2}	rpm	3800	3800	
	minimum	n_{min}	rpm	500	500	
Flow	at $V_{g \max}$ and n_{nom}	q_v	l/min	2 x 115	2 x 148	
Power ⁴⁾	at $V_{g \max}$, n_{nom} and $\Delta p = 380$ bar	P	kW	146	187	
Torque ⁴⁾	at $V_{g \max}$ and	$\Delta p = 300$ bar	T	Nm	334	429
		$\Delta p = 100$ bar	T	Nm	111	143
Rotary stiffness drive shaft	1 1/4 in S7	Pump 1	c_1	Nm/rad	59.401	59.401
		Pump 2	c_2	Nm/rad	13.430	13.430
Moment of inertia (see graphic below)	rotary group 1	J_{TW1}	kgm ²	0.003560	0.003524	
	rotary group 2	J_{TW2}	kgm ²	0.003511	0.003475	
Maximum angular acceleration for each rotary group ⁵⁾		α	rad/s ²	4000	4000	
Case volume		V	L	1.7	1.7	
Weight with HT control (approx.)		m	kg	59	59	

Determination the operating characteristics	
Flow	$q_v = \frac{V_g \times n \times \eta_v}{1000}$ [l/min]
Torque	$T = \frac{V_g \times \Delta p}{20 \times \pi \times \eta_{mh}}$ [Nm]
Power	$P = \frac{2 \pi \times T \times n}{60000} = \frac{q_v \times \Delta p}{600 \times \eta_t}$ [kW]
Key	
V_g	= Displacement per revolution [cm ³]
Δp	= Differential pressure [bar]
n	= Rotational speed [rpm]
η_v	= Volumetric efficiency
η_{mh}	= Mechanical-hydraulic efficiency
η_t	= Total efficiency ($\eta_t = \eta_v \times \eta_{mh}$)

- 1) The values are valid:
 - for the optimum viscosity range of $\nu_{\text{opt}} = 36$ to $16 \text{ mm}^2/\text{s}$
 - with hydraulic fluid based on mineral oil
- 2) Limited maximum speed:
At half corner power (e.g., at $V_{g \max}$ and $p_{\text{nom}}/2$)
- 3) Intermittent maximum speed at:
 - high idle
 - overspeed: $\Delta p = 70$ to 150 bar and $V_{g \max}$
 - reversing peaks: $\Delta p < 300$ bar and $t < 0.1$ s.

▼ Spring-mass system with moment of inertia

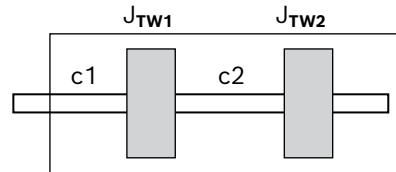

Notes

- Theoretical values, without efficiency levels and tolerances; values rounded
- Operation above the maximum values or below the minimum values may result in a loss of function, a reduced service life or in the destruction of the axial piston unit. Bosch Rexroth recommends checking the loading by means of testing or calculation / simulation and comparison with the permissible values.
- Transport and storage
 - $\theta_{\text{min}} \geq -50$ °C
 - $\theta_{\text{opt}} = +5$ °C to $+20$ °C

- 4) Without boost pump
- 5) The data are valid for values between the minimum required and maximum permissible rotational speed. Valid for external excitation (e. g. diesel engine 2 to 8 times rotary frequency; cardan shaft twice the rotary frequency). The limit value applies for a single pump only. The load capacity of the connection parts must be considered.

Permissible radial and axial forces of the drive shaft

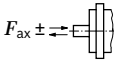
Size	NG	35	45		
Drive shaft		in	1-1/4	1-1/4	
Maximum radial force at distance a (from shaft collar)		$F_{q \max}$	N	3190	3190
		a	mm	24	24
Maximum axial force		$\pm F_{ax \max}$	N	1500	1500

Note

Special requirements apply in the case of belt drive and cardan shaft. Please contact us.

Permissible input and through-drive torques

Size	NG	35	45		
Torque at $V_{g \max}$ and $\Delta p = 420 \text{ bar}^1$	T	Nm	468	602	
Maximum input torque at drive shaft ²⁾	S5	1 in	342	342	
	S7	1-1/4 in	$T_{E \max}$	Nm	602
Maximum through-drive torque	$T_{D1 \max}$	Nm	318	318	
	$T_{D2 \max}$	Nm	$318 - T_2$	$T_{D2 \text{ perm}} = 318 - T_2$	

▼ **Torque distribution**

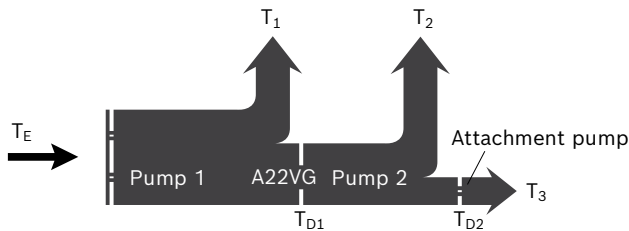

Torque – A21VG	1st pump	T_1
	2nd pump	T_2
Torque – attachment pump		T_3
Input torque	$T_E = T_1 + T_2 + T_3$	
	$T_E < T_{E \max}$	
Through-drive torque	T_{D1}	
	T_{D2}	

- 1) Efficiency not considered
- 2) For drive shafts without radial force

EP – Proportional control electric

The output flow of the pump is infinitely variable between 0 to 100%, proportional to the electrical current supplied to solenoid **a** or **b**.

The electrical energy is converted into a force acting on the control spool. This valve spool then directs control oil into and out of the stroking cylinder to adjust pump displacement as required.

A feedback lever, connected to the stroking piston maintains the pump flow for a given current within the control range.

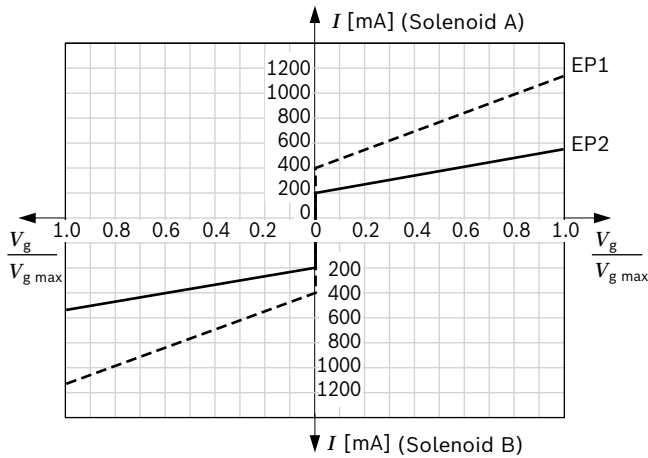

▼ Schematic

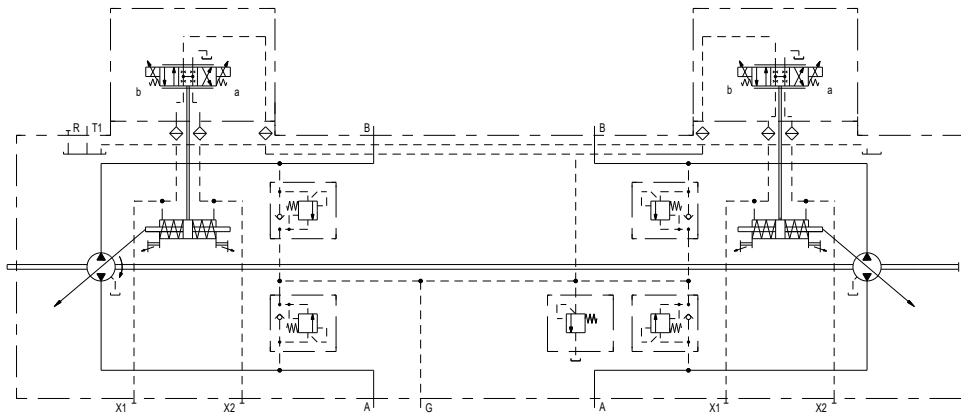

Technical data, solenoid	EP1	EP2
Voltage	12 V ($\pm 20\%$)	24 V ($\pm 20\%$)
Control current		
Beginning of control at $V_g = 0$	400 mA	200 mA
End of control at $V_g \max$	1115 mA	560 mA
Current limit	1.54 A	0.77 A
Nominal resistance (at 20 °C)	5.5 Ω	22.7 Ω
Dither frequency	100 Hz	100 Hz
Duty cycle	100 %	100 %
Type of protection, see connector version on page Page 28		

Various BODAS controllers with application software and amplifiers are available for controlling the proportional solenoids.

Further information can also be found on the internet at www.boschrexroth.com/mobile-electronics.

10 **A21VG series 20** | Axial piston variable double pump
 EP – Proportional control electric

Assignment of direction of rotation, control and flow direction									
Direction of rotation	clockwise				counter-clockwise				
Pump	Pump 1		Pump 2		Pump 1		Pump 2		
Actuation of solenoid	b	a	b	a	b	a	b	a	
Control pressure	X ₁	X ₂	X ₁	X ₂	X ₁	X ₂	X ₁	X ₂	
Flow direction	B to A	A to B	A to B	B to A	A to B	B to A	B to A	A to B	

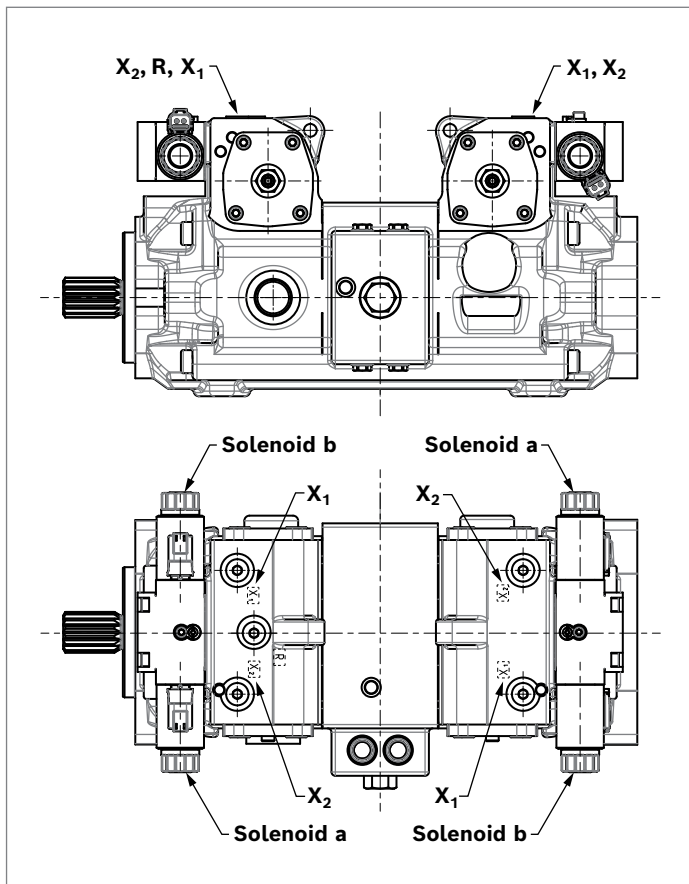

HT – Hydraulic control, direct operated

With the direct hydraulic control, the flow of the pump is influenced by a hydraulic control pressure that is applied directly to the stroking piston through **X₁** or **X₂**. Flow direction is determined by which control pressure port is pressurized (refer to table below).

Pump displacement is infinitely variable and proportional to the applied control pressure, but is also influenced by system pressure and pump drive speed.

Maximum permissible control pressure: 30 bar

Use of the HT control requires a review of the engine and vehicle parameters to ensure that the pump is set up correctly. We recommend that all HT applications be reviewed by a Bosch Rexroth application engineer.

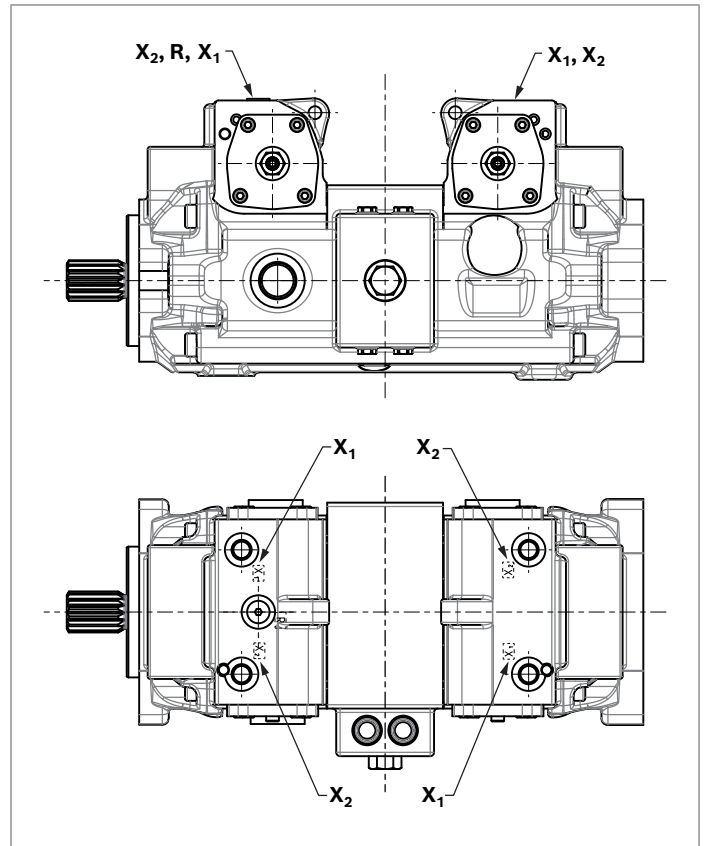

▼ Schematic

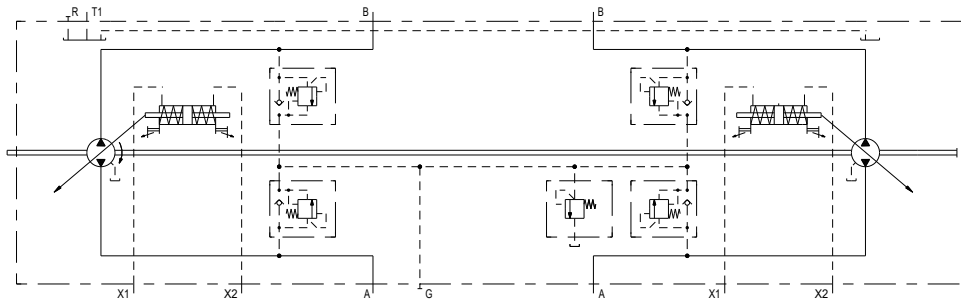

Assignment of direction of rotation, control and flow direction

Direction of rotation	clockwise				counter-clockwise			
	Pump 1		Pump 2		Pump 1		Pump 2	
Control pressure	X ₁	X ₂	X ₁	X ₂	X ₁	X ₂	X ₁	X ₂
Flow direction	B to A	A to B	A to B	B to A	A to B	B to A	B to A	A to B

HW – Proportional control hydraulic, mechanical servo

The output flow of the pump is infinitely variable between 0 to 100%, proportional to the swivel angle of the control lever.

A feedback lever, connected to the stroking piston maintains the pump flow for a given position of the control lever.

If the pump is also equipped with a DA control valve (see page Page 25), automotive operation is possible for travel drives.

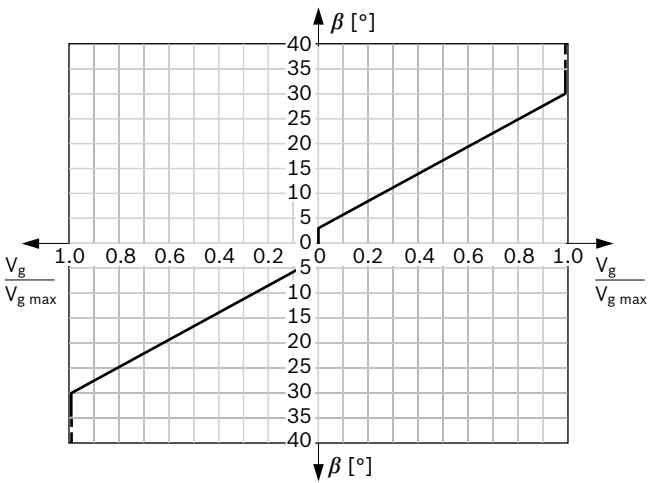

Swivel angle β at the control lever for pump displacement change:

- ▶ Start of control at $\beta = \pm 3^\circ$
- ▶ End of control at β (max. displacement $V_{g\max}$) at $\pm 30^\circ$
- ▶ Rotation limiting β of the control lever (internal) $\pm 38^\circ$

The maximum required torque at the lever is 170 Ncm. To prevent damage to the HW control module, a mechanical stop must be provided by the customer for the HW control lever.

Note

Spring centering enables the pump, depending on pressure and rotational speed, to move automatically to the neutral position ($V_g = 0$) as soon as there is no longer any torque on the control lever of the HW control module (regardless of deflection angle).

Variation: Neutral position switch

The switch contact in the neutral position switch is closed when the control lever on the HW control module is in its neutral position. The switch opens when the control lever is moved out of neutral in either direction.

Thus, the neutral position switch provides a monitoring function for drive units that require the pump to be in the neutral position during certain operating conditions (e.g. starting diesel engines).

Technical data

Load capacity	20 A (continuous), without switching operations
Switching capacity	15 A / 32 V (resistive load) 4 A / 32 V (inductive load)
Connector version	DEUTSCH DT04-2P-EP04 (Mating connector, see page Page 28)

▼ Schematic

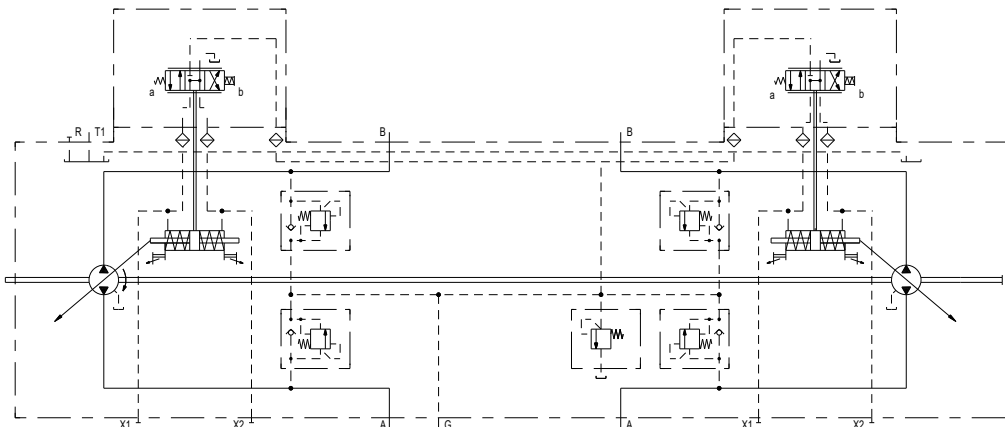

Assignment of direction of rotation, control and flow direction

Direction of rotation	clockwise				counter-clockwise			
	Pump 1		Pump 2		Pump 1		Pump 2	
Lever direction	a	b	a	b	a	b	a	b
Control pressure	X ₁	X ₂	X ₁	X ₂	X ₁	X ₂	X ₁	X ₂
Flow direction	B to A	A to B	A to B	B to A	A to B	B to A	B to A	A to B

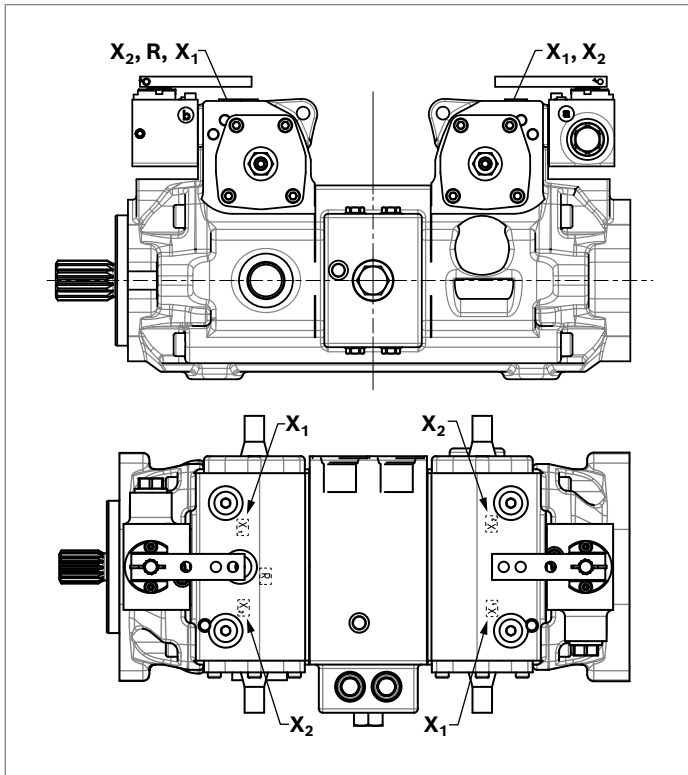

ET – Electric control, direct operated

The output flow of the pump is infinitely variable in the range 0 to 100%. Depending on the preselected current I (mA) at solenoids **a** and **b** of the pressure reducing valves, the stroking cylinder of the pump is proportionally supplied with control pressure. The pump displacement that arises at a certain control current is dependent on the rotational speed and operating pressure of the pump. A different flow direction is associated with each pressure reducing valve. Maximum permissible control pressure: 30 bar

Technical data, solenoid	ET1	ET2
On-board voltage in the vehicle	12 V	24 V
Permissible voltage U	9.6 ... 28.8 V	
Current limit	1.5 A	
Nominal resistance (at 20 °C)	3.3 Ω	
Dither		
Frequency	100 Hz	
Minimum oscillation range ¹⁾	250 mA	
Duty cycle	100 %	
Type of protection, see connector version on Page 28		

1) Minimum required oscillation range of the control current ΔI_{p-p} (peak to peak) within the respective control range (start of control to end of control).

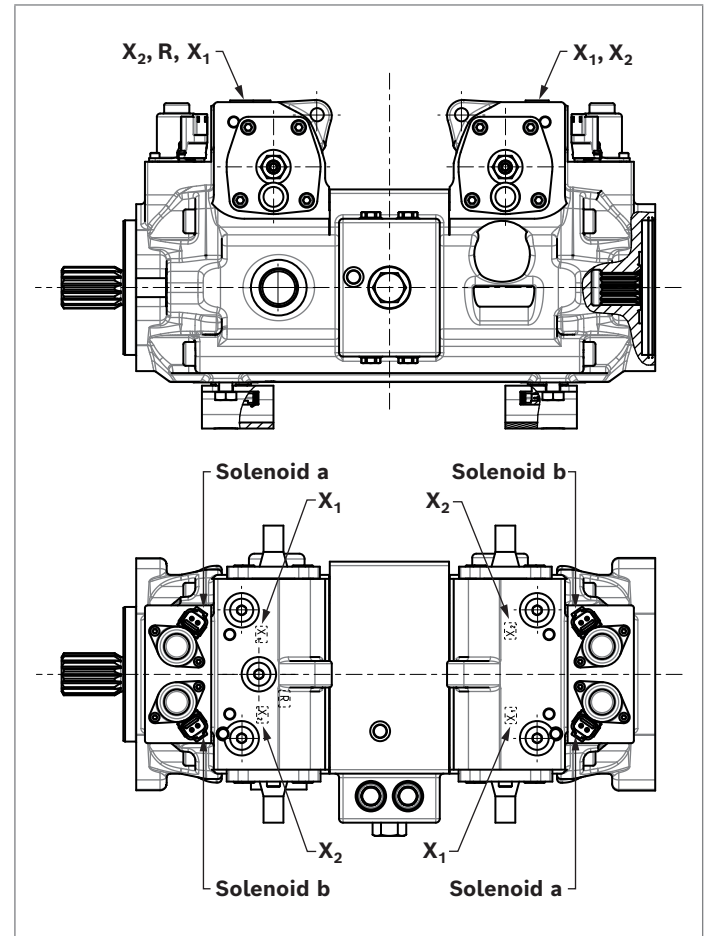

▼ Schematic

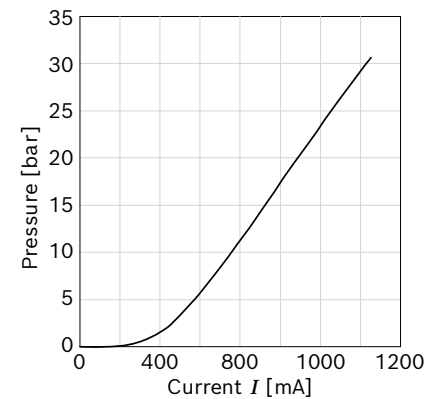
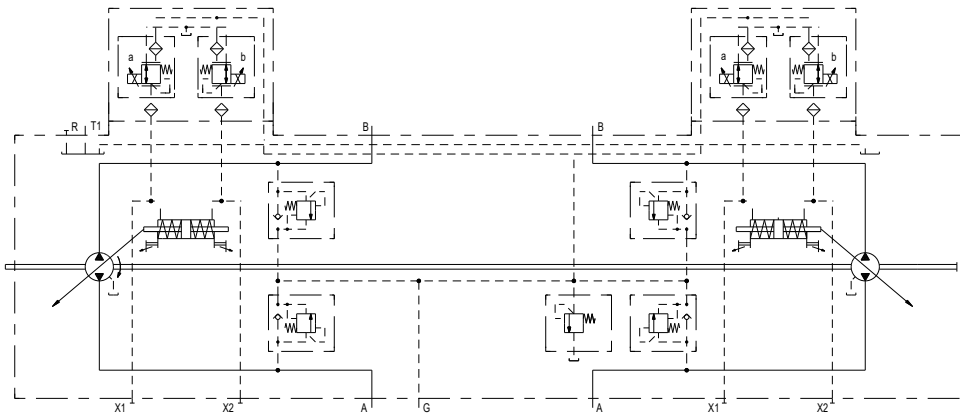

Assignment of direction of rotation, control and flow direction

Direction of rotation	clockwise				counter-clockwise			
	Pump 1		Pump 2		Pump 1		Pump 2	
Actuation of solenoid	a	b	a	b	a	b	a	b
Control pressure	X ₁	X ₂	X ₁	X ₂	X ₁	X ₂	X ₁	X ₂
Flow direction	B to A	A to B	A to B	B to A	A to B	B to A	B to A	A to B

eEP – Proportional Control Operation with electronic feedback

The pump displacement electronic control characteristic is similar to the EP controller, which can now be achieved by using the ET controller in conjunction with swashplate angle sensors and Rexroth’s RC controller and software. Our traditional EP controller uses a feedback lever to mechanically compensate the pump displacement and achieve a high level of accuracy and response time in order to provide constant flow for given current input independent from the load pressure.

The design of the A21VG pump, including the placement and design integration of the angle sensors, has been setup such that the effect of tolerances are minimized and best-in-class control performance can be achieved. A pump with load dependent ET functionality – where load pressure deflects the swash plate position – can have now added load compensation by a simple programming parameter to emulate EP functionality. In the end, the control algorithm achieves perfect linearity, with minimal hysteresis, independently of the hydraulic unit load pressure.

With the potential to use the eEP option, customers can design machines to suit operator’s personal preference on how they would like to control the machine without the need to change hardware. Some customers may prefer to have “soft controllability” of the pump where they would want to feel the influence of pump operating pressure relative to their input command. Other customers may prefer the pump to have “hard controllability” where the pump swivels to commanded displacement regardless of the pump operating pressure. Both “hard” and “soft” functionality can be achieved via a simple programming change on-the-fly. This opens up possibilities for different drive modes available to the machine operator and allows the OEM to program behavior preferences based on other machine operating parameters.

Assignment of direction of rotation, control and flow direction								
Direction of rotation	clockwise				counter-clockwise			
	Pump 1		Pump 2		Pump 1		Pump 2	
Actuation of solenoid	a	b	a	b	a	b	a	b
Control pressure	X ₁	X ₂	X ₁	X ₂	X ₁	X ₂	X ₁	X ₂
Flow direction	B to A	A to B	A to B	B to A	A to B	B to A	B to A	A to B
Ch1, Pin 4 ¹⁾	0.7 V	4.3 V	0.7 V	4.3 V	0.7 V	4.3 V	0.7 V	4.3 V
Ch2, Pin 1 ¹⁾	4.3 V	0.7 V	4.3 V	0.7 V	4.3 V	0.7 V	4.3 V	0.7 V

1) Angle sensor voltage @ V_{g max}

Dimensions

ET.D – Electric control, direct operated with angle sensor

Threaded ports A and B, on left side (viewed on drive shaft)

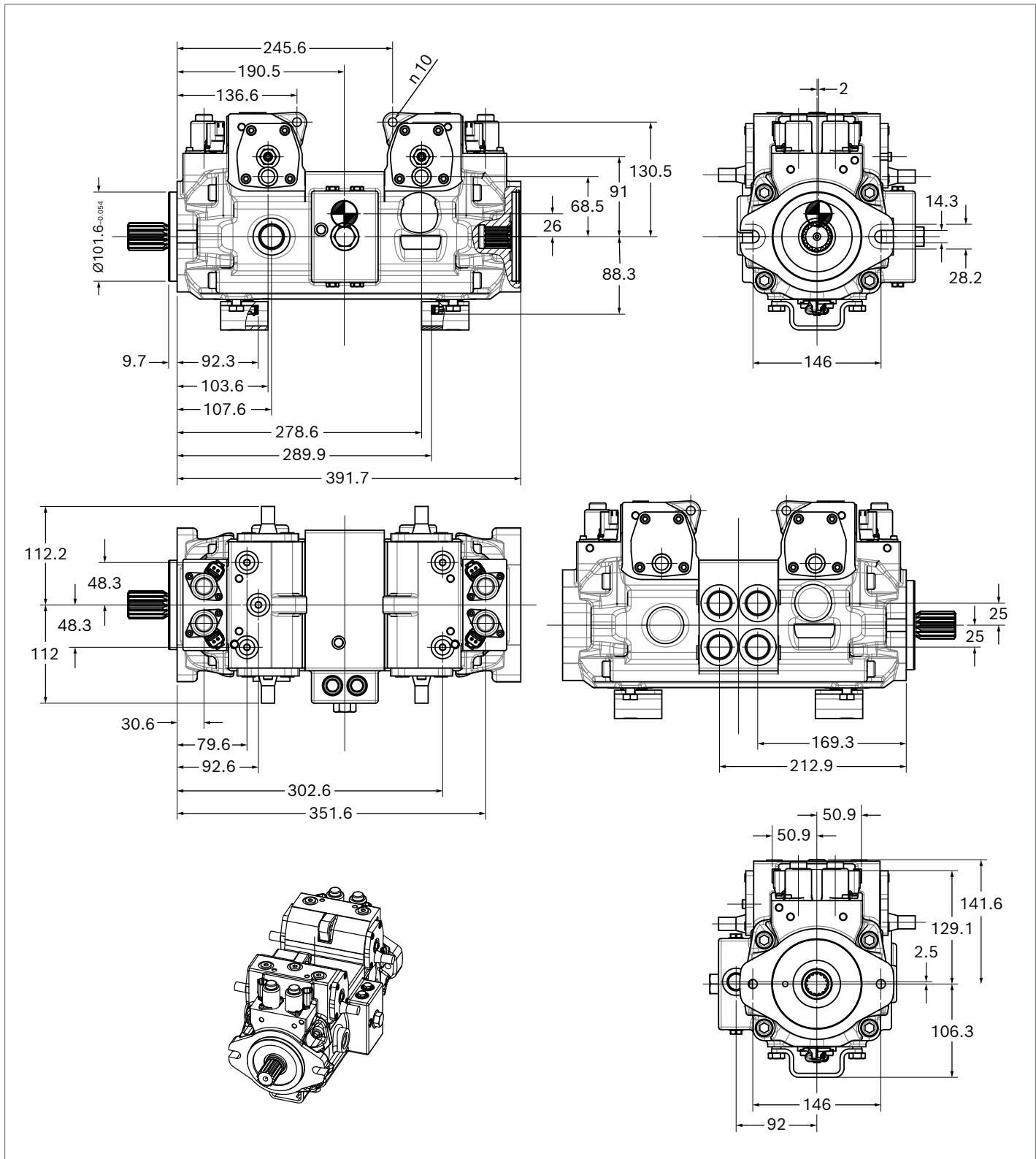

⊕ Center of gravity

▼ Splined shaft SAE J744

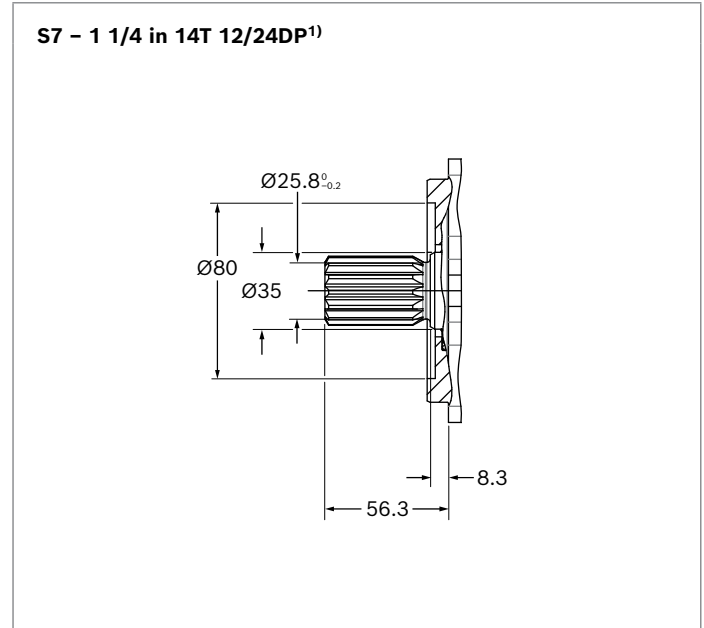
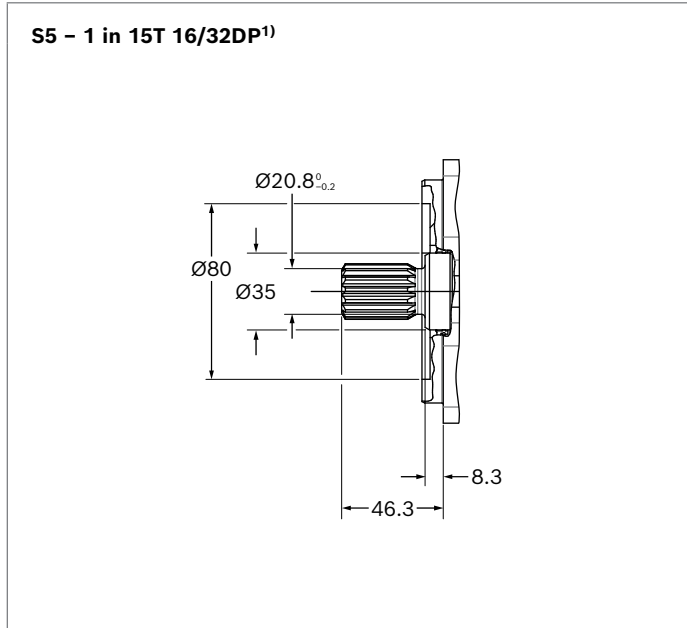

Ports		Standard ³⁾	Size [in] ⁴⁾	$p_{\max \text{ abs}}$ [bar] ⁵⁾	State ⁶⁾
A, B	Working port	ISO 11926	1 1/16-12 UN-2B; 20 deep	450	O
T	Drain port	ISO 11926	1 1/16-12 UN-2B; 20 deep	3	O
R	Air bleed on pump 1	ISO 11926	9/16-18 UNF-2B; 13 deep	3	X
X₁, X₂	Control pressure (upstream of orifice, only HP, HW, EP, ET)	ISO 11926	9/16-18 UNF-2B; 13 deep	30	X
X₁, X₂	Control pressure (HT)	ISO 11926	9/16-18 UNF-2B; 13 deep	30	O
Y	Pilot pressure, outlet (only for DA control valve)	ISO 11926	9/16-18 UNF-2B; 13 deep	30	O
G	Boost pressure, inlet	ISO 11926	3/4-16 UNF-2B; 15 deep	30	O
Y_{BR}	Brake release pressure	ISO 11926	9/16-18 UNF-2B; 13 deep	30	X
P_S	Pilot pressure supply (filtered internally)	ISO 11926	9/16-18 UNF-2B; 13 deep	30	X
G₁	Boost pressure, inlet (only for DA control valve)	ISO 11926	9/16-18 UNF-2B; 13 deep	30	X

1) Involute spline according to ANSI B92.1a, 30° pressure angle, flat root, side fit, tolerance class 5
 2) Thread according to ASME B1.1
 3) The spot face can be deeper than specified in the appropriate standard.
 4) For notes on tightening torques, see instruction manual

5) Momentary pressure spikes may occur depending on the application. Keep this in mind when selecting measuring devices and fittings.
 6) O = Must be connected (plugged on delivery)
 X = Plugged (normal operation)

▼ **EP – Proportional control, electric**

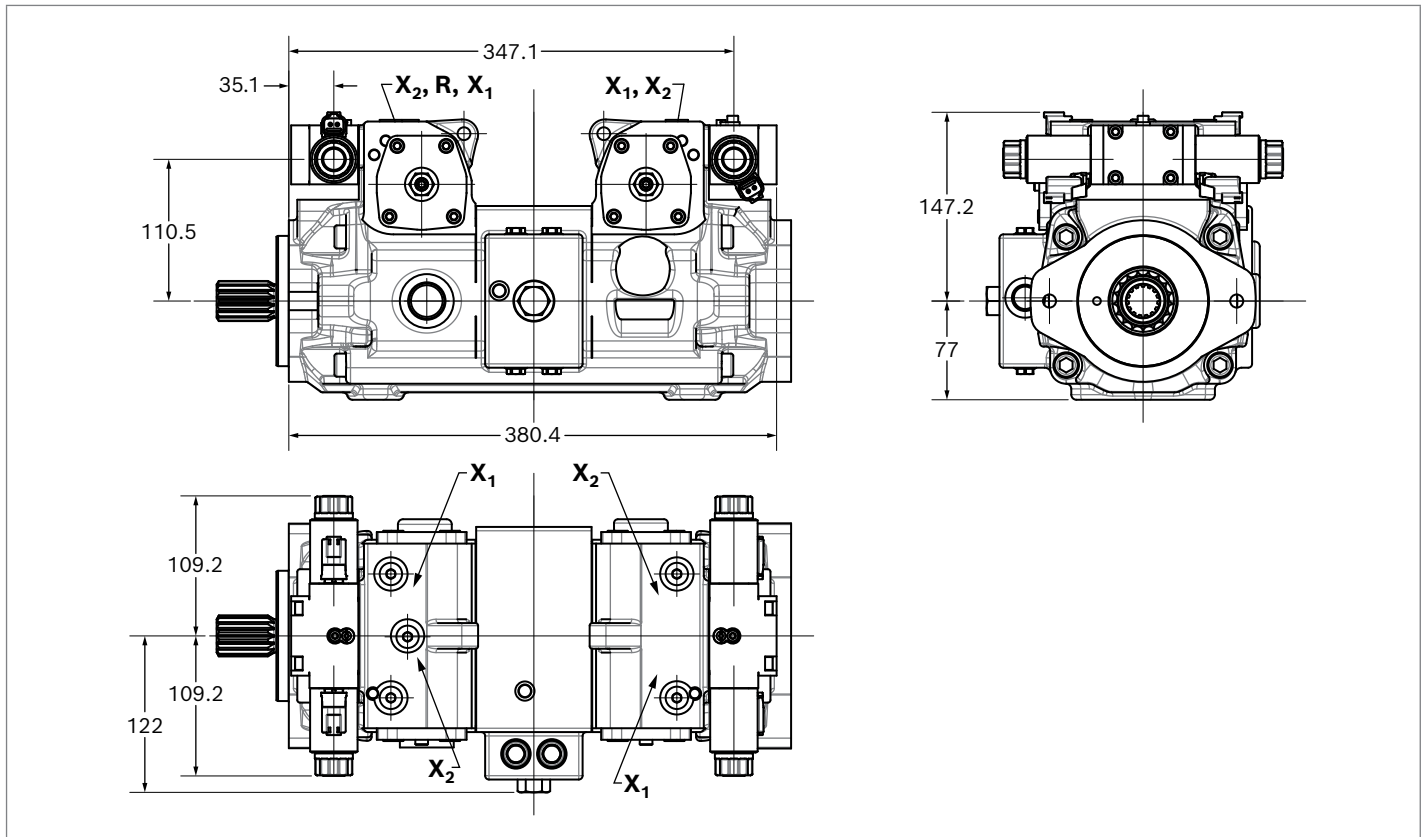

▼ **HT – Hydraulic control, direct operated**

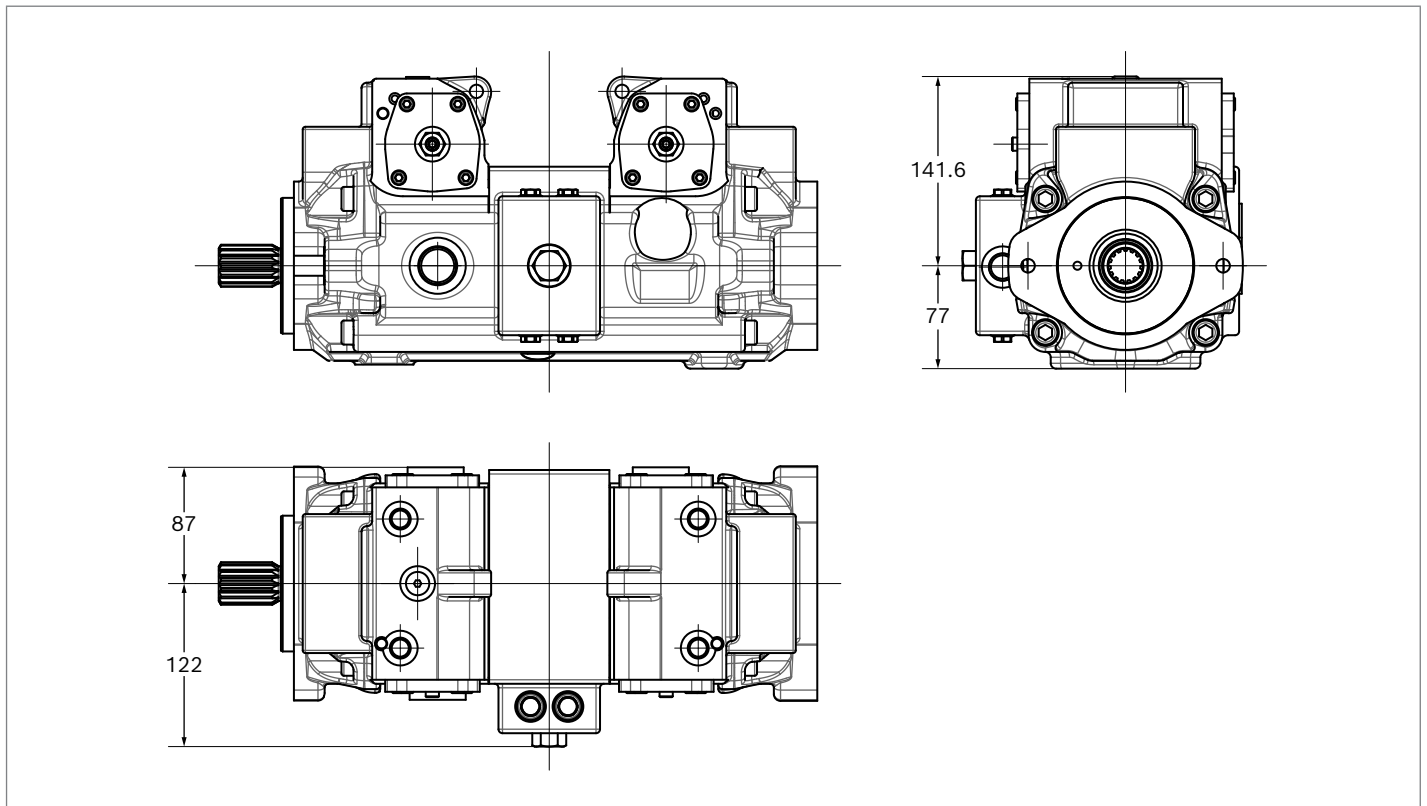

▼ HW – Proportional control hydraulic, mechanical servo

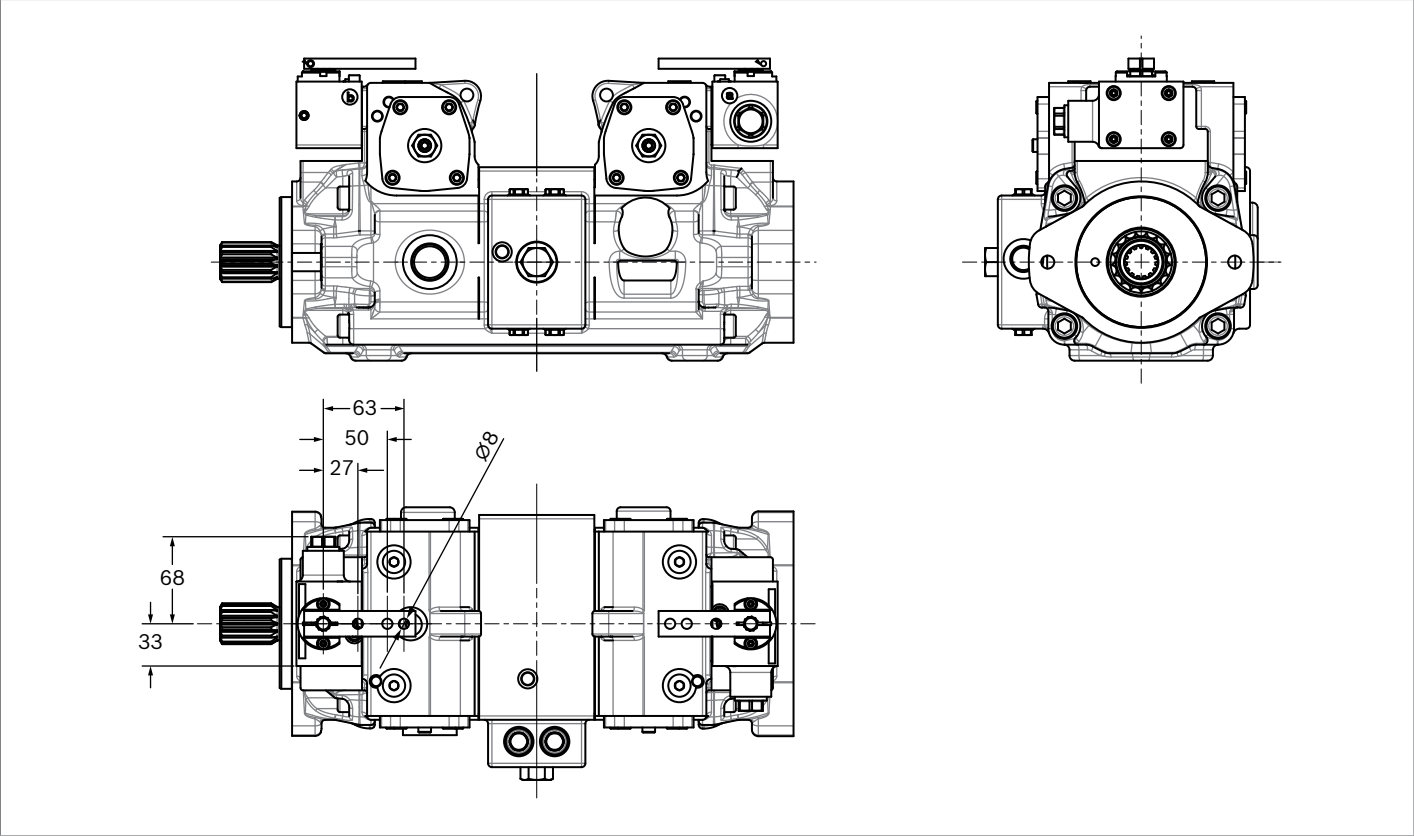

Through drive dimensions

Flange SAE J744 ¹⁾			Hub for splined shaft ²⁾					
Diameter	Mounting ³⁾	Code	Diameter		Code	045	035	
Without through drive								
82-2 (A)	∞	A2	5/8 in	9T 16/32DP	S2	●	●	0000
		A2	3/4 in	11T 16/32DP	S3	●	●	A2S2
		A2	7/8 in	13T 16/32DP	S4	●	●	A2S3
101-2 (B)	∞	B2	7/8 in	13T 16/32DP	S4	●	●	A2S4
		B2	1 in	15T 16/32DP	S5	●	●	B2S4
		B2	1 in	15T 16/32DP	S5	●	●	B2S5

▼ 101-2

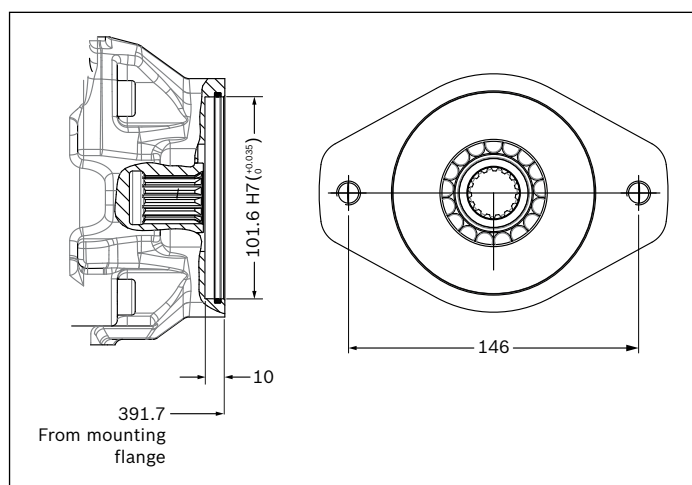

▼ 82-2

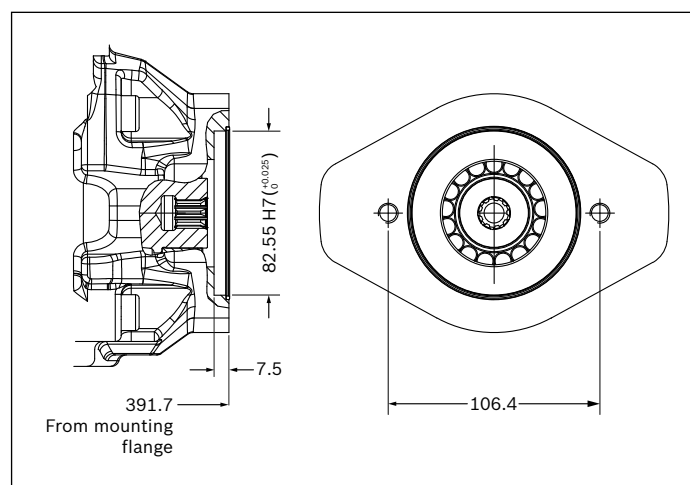

Overview of attachment options

Through drive			Attachment option - additional pumps		
Flange	Hub for splined shaft	Code	A10VG NG (shaft)	A10V(S)O/5x NG (shaft)	External gear pump ⁶⁾
82-2 (A)	5/8 in	A2S2	—	10, 18 (U)	AZPF, AZPS NG4 ... 28 AZPW NG5 ... 22
101-2 (B)	7/8 in	B2S4	18 (S)	28(S) 45 (U)	—
	1 in	B2S5	28, 45 (S)	45 (S) 60 (U)	—

Combination pumps

By using combination pumps, it is possible to have independent circuits without the need for splitter gearboxes. When ordering combination pumps, the type designations of the 1st and 2nd pump must be linked by a "+".

Ordering example

A21VG45ET1PD0/10AR + AZPN....

The A21VG variable double pump is permissible without additional supports where the dynamic mass acceleration does not exceed maximum 10 g (= 98.1 m/s²). When mounting another pump on the A21VG, the mounting flange must be rated for the permissible mass torque.

- 1) The through-drive flange is only supplied with the fastening thread corresponding to the ordering code designation.
- 2) According to ANSI B92.1a, 30° pressure angle, flat root, side fit, tolerance class 5
- 3) Mounting drillings pattern viewed on through drive, with control at top

- 4) Thread according to ASME B1.1, for notes on tightening torques, see instruction manual
- 5) O-ring included in the scope of delivery
- 6) Bosch Rexroth recommends special versions of the external gear pumps. Please contact us.

High-pressure relief valves

The four high-pressure relief valves protect the hydrostatic transmission (pump and motor) from overload. They limit the maximum pressure in the respective high-pressure line and serve simultaneously as boost valves.

High-pressure relief valves are not working valves and are only suitable for pressure spikes or high rates of pressure change.

- ▶ The valve settings are preset and the cracking pressures may have deviations due to changes in the operating parameters.
- ▶ The differential pressure setting is preset in the range $\Delta p = 250$ to 420 bar in increments of 10 bar.
- ▶ When ordering, state differential pressure setting in plain text.

Setting the valves

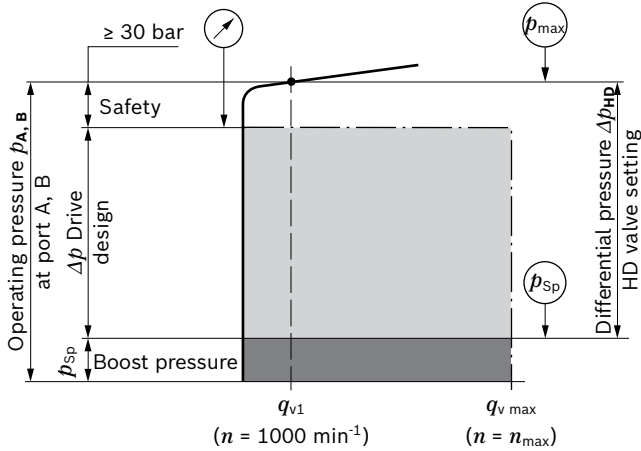

Settings on high-pressure relief valve A and B (Pump 1 and 2)	
Differential pressure setting	$\Delta p_{HD} = 420$ bar
Cracking pressure of the HD valve (at q_{v1})	$p_{max} = \dots$ bar ($p_{max} = \Delta p_{HD} + p_{sp}$)

Mechanical stroke limiter

The mechanical stroke limiter is an additional function allowing the maximum displacement of the pump to be steplessly reduced, regardless of the control module used. Standard unit includes variable mechanical stroke limiters on both sides of the pump so that maximum displacement can be limited for any of the outlet ports.

Dimensions

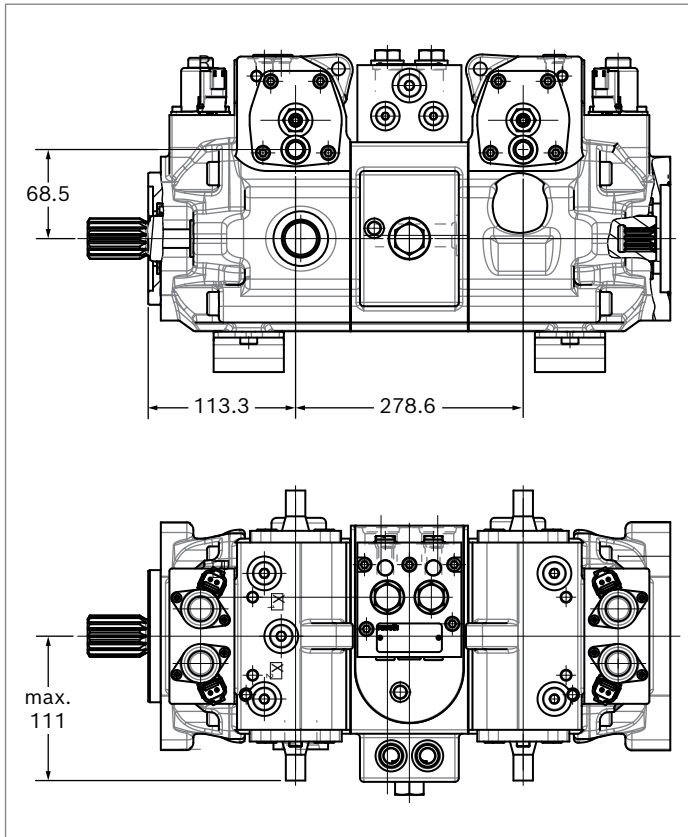

▼ Schematic

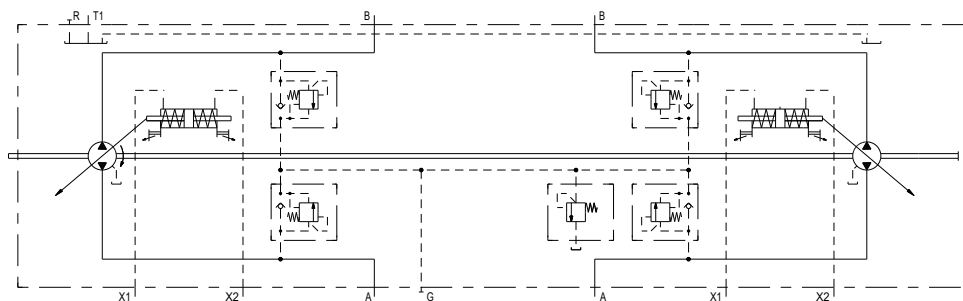

Pilot shut-off valve (Neutral valve)

Actuation of the switching solenoid enables pilot pressure to flow through to the control device of the front and rear pump. When the solenoid is de-energized, this connection is interrupted and the pilot pressure to the control devices is relieved to the pump housing. This ensures the pump is torque-free and the swash plate returns to neutral position (no flow condition).

Another function of the pilot shutoff valve is that it can be also used as a brake release valve. The YBR port can be used to send pressure signal to release the brakes when the solenoid is energized. In the de-energized state, the brake release pressure will be relieved to the pump housing.

Dimensions

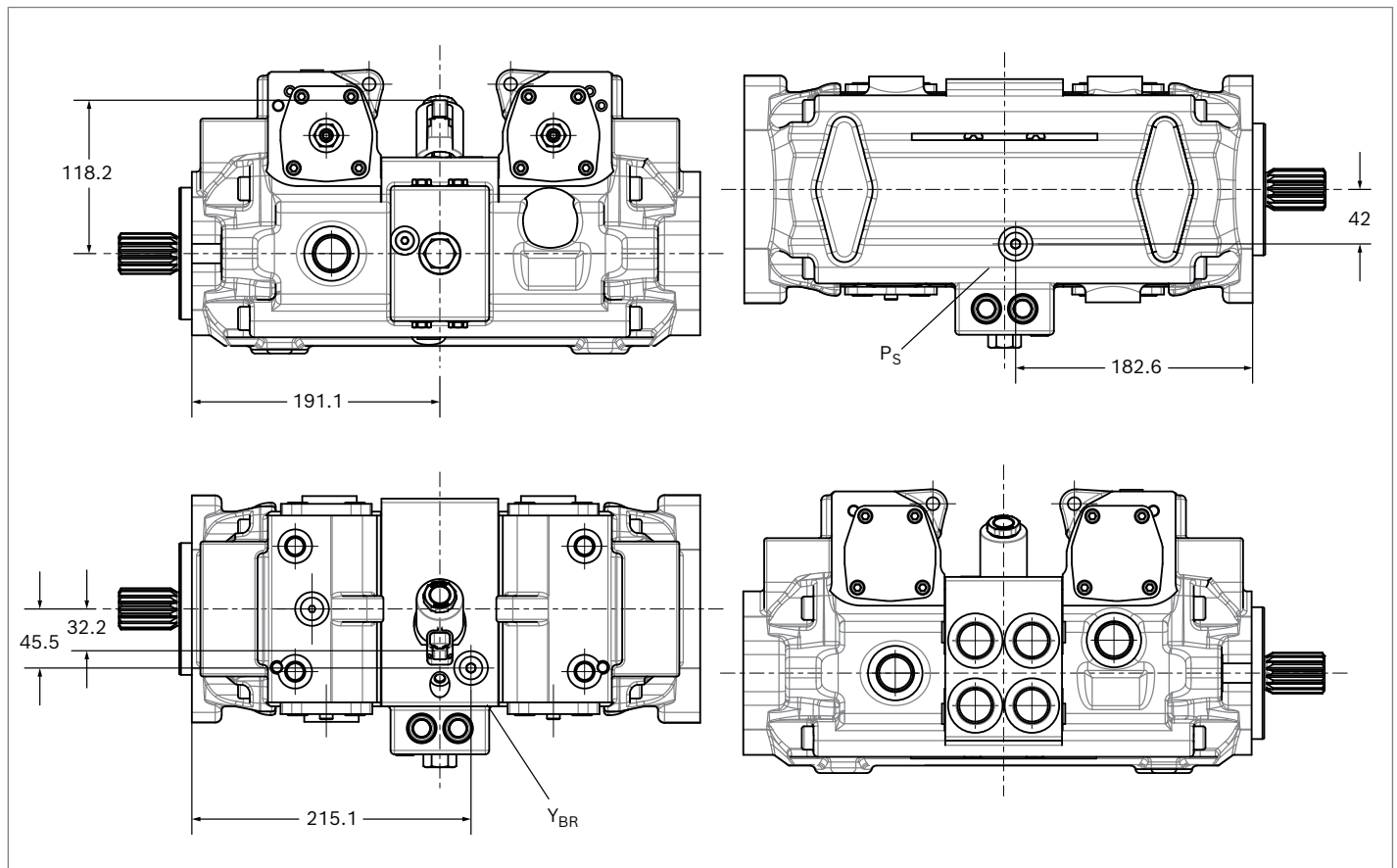

Technical Data

Voltage	12V	24 V
Neutral position $V_g = 0$	de-energized	de-energized
Position V_g max	Current switched on	Current switched on
Nominal resistance (at 20 °C)	7.4 Ω ($\pm 7\%$)	28.4 Ω ($\pm 7\%$)
Nominal power	20 W	20 W
Nominal current	1.04 A	0.54 A
Max. current	1.67 A	0.83 A

▼ **Schematic**

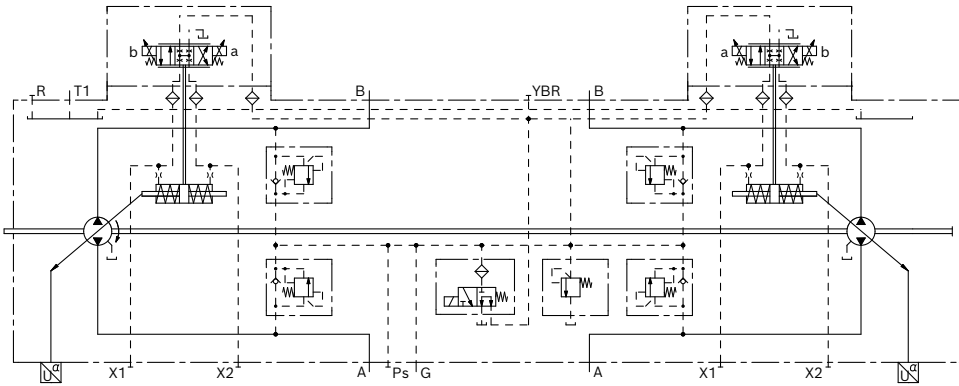

Port for	Standard	Size (in)	State	
Y _{BR}	Pressure port for auxiliary circuit	ISO 11926	9/16-18 UNF-2B 13 deep	Plugged
P _S	Pressure port for auxiliary circuit	ISO 11926	9/16-18 UNF-2B 13 deep	Plugged

DA – Control valve, fixed setting

Speed related pilot pressure supply

The DA closed loop control is an engine speed-dependent system for travel drives. The built-in DA control valve generates a pilot pressure which is proportional to pump (engine) drive speed. The pump displacement is infinitely variable in each flow direction and is influenced by both pump drive speed and system pressure.

Increasing the pump drive speed causes the DA control valve to generate a higher pilot pressure with a resulting increase in the flow from the pump. Depending on the selected pump operating characteristics, increasing system pressure (e.g. machine load) causes the pump to swivel back towards a smaller displacement. Diesel engine overload protection (anti-stall) is achieved by the combination of this pressure-related pump de-stroking, and the reduction of pilot pressure as the engine speed drops.

Any additional power requirement, e.g. for hydraulic functions from attachments, could cause the engine speed to drop further. This would cause a further reduction in pilot pressure and thus of pump displacement. Automatic power distribution and full exploitation of the available power are achieved in this way, both for the travel drive and for the implement hydraulics, with priority given to the implement hydraulics.

The DA control valve can also be used in pumps with EP, HT and HW control modules to protect the combustion engine against overload. DA closed loop control is only suitable for certain types of drive systems and requires review of the engine and vehicle parameters to ensure that the pump is used correctly and that machine operation is safe and efficient. We recommend that all DA applications be reviewed by a Bosch Rexroth application engineer.

Dimensions

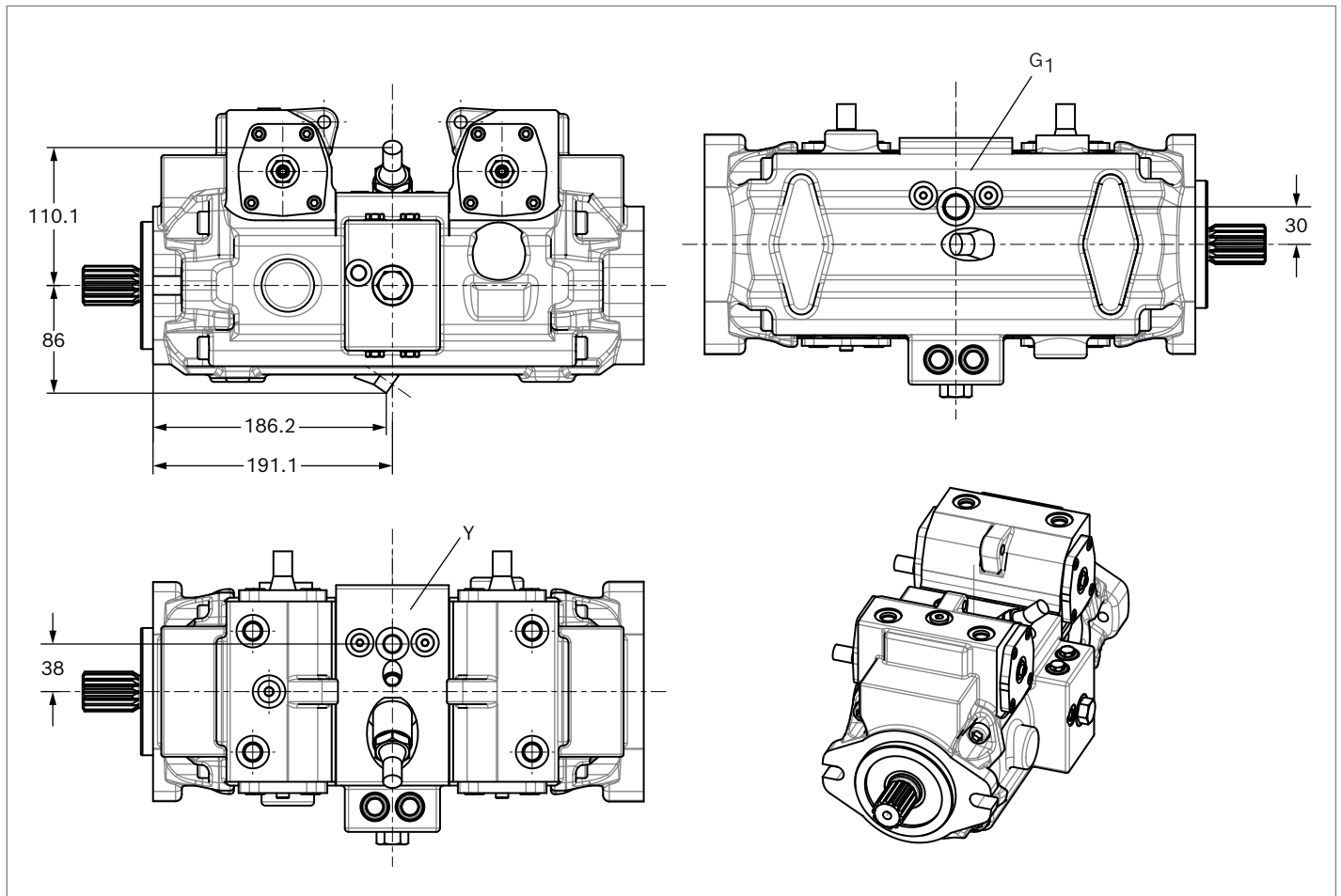

▼ **Schematic**

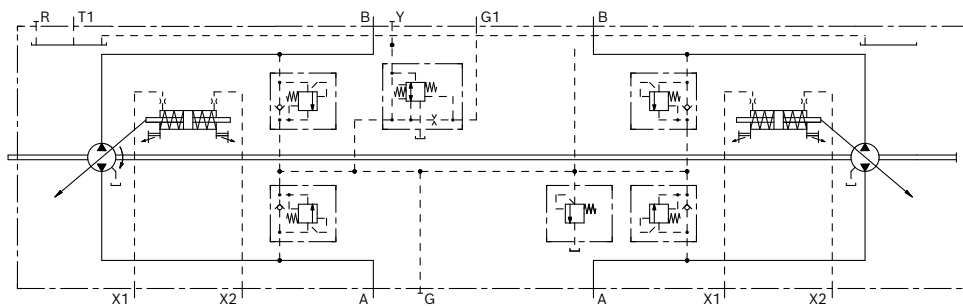

	Port for	Standard	Size		State
G ₁	Boost pressure, inlet	ISO 11926	3/4-16 UNF-2B	13 deep	Open
Y	Pilot pressure, outlet	ISO 11926	9/16-18 UNF-2B	13 deep	Open

Swivel angle sensor

For the swivel angle indicator, the pump swivel angle is measured by an electric swivel angle sensor. As an output parameter, the Hall-effect swivel angle sensor delivers a voltage proportional to the swivel angle (see table of output voltages). Please contact us if the swivel angle sensor is used for control.

Characteristics	
Supply voltage U_b	4.75 to 5.25V DC
Output voltage U_a	Ch1, Pin 4: 0.7V 2.5V 4.3V Ch2, Pin 1: 4.3V 2.5V 0.7V
Reverse polarity protection	Short circuit-resistant
Under voltage detection	3.75 to 4.05 V DC
Over voltage limit (48h max for life)	28V
EMC resistance	Details on request
Operating temperature range	-40 °C to +125 °C
Vibration resistance ISO 16750-3	5 to 2000 Hz
Shock resistance DIN EN 60068-2-27	25g
Salt spray resistance DIN EN 60068-2-11	240h
Type of protection ISO 20653 (with plugged mating connector and cable)	IP6kx, IPX6, IPx7 and IPX9k
Housing material	Plastic

Reference: RE95161

Output voltage

Direction of rotation	Flow direction ¹⁾	Output voltage
cw	B to A	> 2.5 V
	A to B	< 2.5 V
ccw	A to B	> 2.5 V
	B to A	< 2.5 V

▼ Schematic

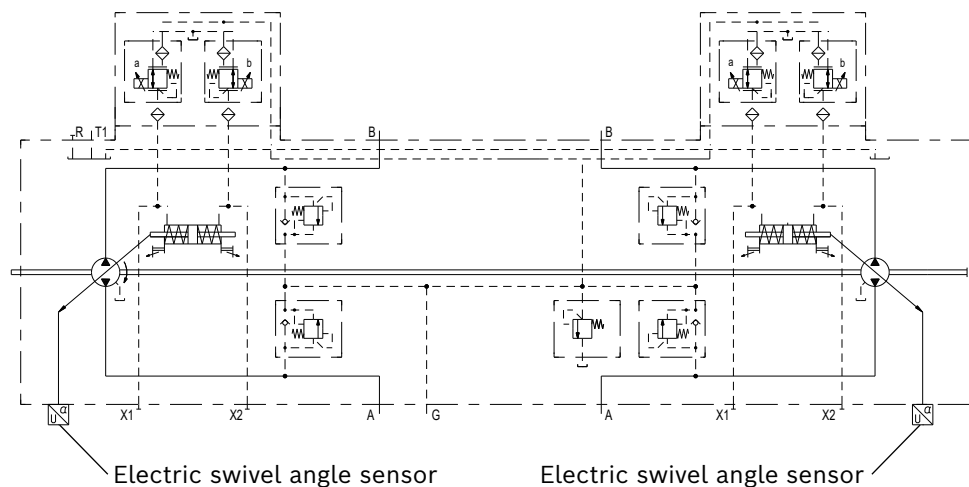

1) For flow direction, see controls

Dimensions

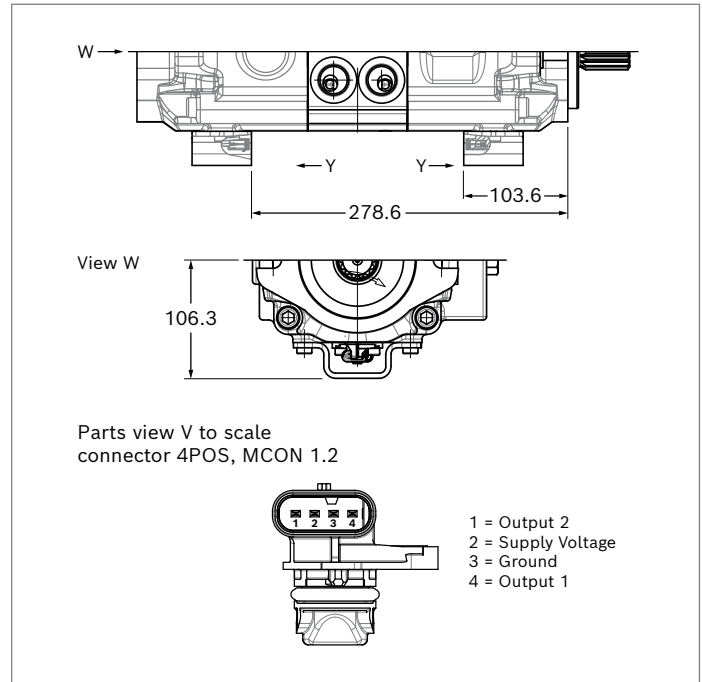

▼ Mating connector set

Item	Designation
1	4POS, MCON 1.2 CB REC 2p TL SEALED
2	MCON 1.2 CB REC SWS SN
3	Wire seal, rubber, red
4	Plug, blue

Reference: RE95161

The mating connector is not included in the scope of delivery. This can be supplied by Bosch Rexroth on request (material number R917012863).

Connector for solenoids

DEUTSCH DT04-2P-EP04

Molded, 2-pin, without bidirectional suppressor diode.
There is the following type of protection with mounted mating connector:

- ▶ IP67 (DIN/EN 60529) and
- ▶ IP69K (DIN 40050-9)

▼ Circuit symbol

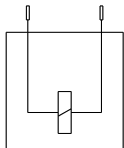

▼ Mating connector DEUTSCH DT06-2S-EP04

Consisting of	DT designation
1 housing	DT06-2S-EP04
1 wedge	W2S
2 sockets	0462-201-16141

The mating connector is not included in the scope of delivery. This can be supplied by Bosch Rexroth on request (material number R902601804).

Note

- ▶ If necessary, you can change the connector orientation by turning the solenoid housing.
- ▶ Refer to the instruction manual for the procedure.

Installation dimensions for coupling assembly

To ensure that rotating components (coupling hub) and fixed components (housing) do not come into contact with each other, the installation conditions described in the installation drawing must be observed. This depends on the size and the splined shaft.

Installation instructions

General

During commissioning and operation, the axial piston unit must be filled with hydraulic fluid and air bled. This must also be observed following a relatively long standstill as the axial piston unit may drain back to the reservoir via the hydraulic lines.

The leakage in the housing must be directed to the reservoir via the highest drain port **T**. For combinations of multiple units, the leakage must be drained at each pump. If a shared drain line is used for this purpose, make certain that the respective case pressure is not exceeded. In the event of pressure differences at the drain ports of the units, the shared drain line must be changed so that the minimum permissible case pressure of all connected units is not exceeded in any situation. If this is not possible, separate drain lines must be laid if necessary.

To achieve favorable noise values, decouple all connecting lines using elastic elements and avoid above-reservoir installation. In all operating conditions, the suction and drain lines must flow into the reservoir below the minimum fluid level. The permissible suction height h_s results from the overall loss of pressure; it must not, however, be higher than $h_{s \max} = 800$ mm. The minimum suction pressure at port **S** must also not fall below 0.8 bar absolute during operation (cold start 0.5 bar absolute).

When designing the reservoir, ensure adequate space between the suction line and the drain line. This prevents the heated, return flow from being drawn directly back into the suction line.

Installation position

See the following examples 1 to 4.

Further installation positions are possible upon request.

Notes

- ▶ If it is not possible to fill the stroking chambers via **X₁** to **X₂** in the final installation position, this must be done prior to installation.
- ▶ To prevent unexpected actuation and damage, the stroking chambers must be air bled via ports **X₁** or **X₂** depending on the installation position.
- ▶ In certain installation positions, an influence on the control characteristics can be expected. Gravity, dead weight and case pressure can cause minor shifts in control characteristics and changes in response time.

Key	
L	Filling / air bleed
R	Air bleed port
S	Suction port
T	Drain port
SB	Baffle (baffle plate)
$h_{t \min}$	Minimum required immersion depth (200 mm)
h_{\min}	Minimum required distance to reservoir bottom (100 mm)
$h_{s \max}$	Maximum permissible suction height (800 mm)

Below-reservoir installation (standard)

Below-reservoir installation means that the axial piston unit is installed outside of the reservoir below the minimum fluid level.

Installation position	Air bleed the housing	Air bleed the stroking chamber	Filling
1 Without boost pump	R	X ₁ , X ₂	T + X ₁ + X ₂

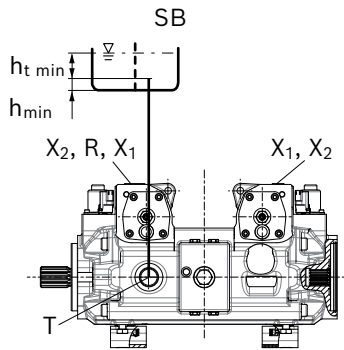

2 Without boost pump	-	-	T
----------------------	---	---	---

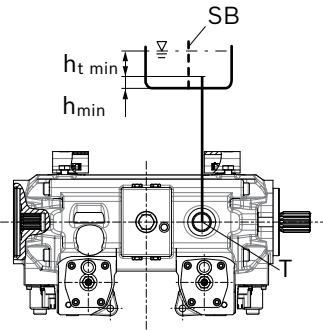

Above-reservoir installation

Above-reservoir installation means that the axial piston unit is installed above the minimum fluid level of the reservoir. Observe the maximum permissible suction height $h_{S \max} = 800$ mm.

Installation position	Air bleed the housing	Air bleed the stroking chamber	Filling
3 Without boost pump	R	X ₁ , X ₂	L ₁ + X ₁ + X ₂

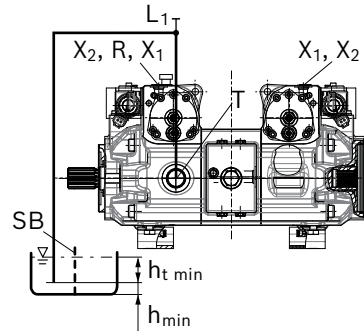

4 Without boost pump	L ₁	-	L ₁
----------------------	----------------	---	----------------

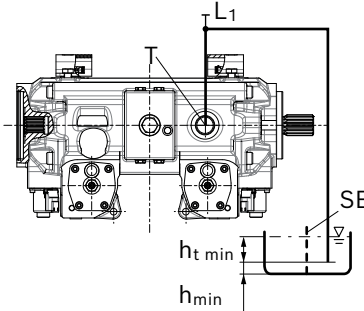

For legend and notes, see page Page 29.

Project planning notes

- ▶ The pump A21VG is designed to be used in closed circuit.
- ▶ The project planning, installation and commissioning of the axial piston unit requires the involvement of qualified skilled personnel.
- ▶ Before using the axial piston unit, please read the corresponding instruction manual completely and thoroughly. If necessary, these can be requested from Bosch Rexroth.
- ▶ Before finalizing your design, please request a binding installation drawing.
- ▶ The specified data and notes contained herein must be observed.
- ▶ Depending on the operating conditions of the axial piston unit (working pressure, fluid temperature), the characteristic curve may shift.
- ▶ Preservation: Our axial piston units are supplied as standard with preservative protection for a maximum of 12 months. If longer preservative protection is required (maximum 24 months), please specify this in plain text when placing your order. The preservation periods apply under optimal storage conditions, details of which can be found in the data sheet 90312 or the instruction manual.
- ▶ Not all versions of the product are approved for use in a safety function according to ISO 13849. Please consult the responsible contact person at Bosch Rexroth if you require reliability parameters (e.g. $MTTF_d$) for functional safety.
- ▶ Depending on the type of control used, electromagnetic effects can be produced when using solenoids. When a direct current is applied, solenoids do not cause electromagnetic interference nor is their operation impaired by electromagnetic interference. Other behavior can result when a modulated direct current (e.g. PWM signal) is applied. Potential electromagnetic interference for persons (e.g. persons with a pacemaker) and other components must be tested by the machine manufacturer.
- ▶ The pressure cut-off is not a safeguard against pressure overload. Be sure to add a pressure relief valve to the hydraulic system.
- ▶ Please note the details regarding the tightening torques of port threads and other threaded joints in the instruction manual.
- ▶ Working ports:
 - The ports and fastening threads are designed for the specified maximum pressure. The machine or system manufacturer must ensure that the connecting elements and lines correspond to the specified application conditions (pressure, flow, hydraulic fluid, temperature) with the necessary safety factors.
 - The working ports and function ports are only intended to accommodate hydraulic lines.

Safety instructions

- ▶ During and shortly after operation, there is a risk of getting burnt on the axial piston unit and especially on the solenoids. Take appropriate safety measures (e.g. by wearing protective clothing).
- ▶ Moving parts in control equipment (e.g. valve spools) can, under certain circumstances get stuck in position as a result of contamination (e.g. impure hydraulic fluid, abrasion, or residual dirt from components). As a result, the hydraulic fluid flow and the build-up of torque in the axial piston unit can no longer respond correctly to the operator's specifications. Even the use of various filter elements (external or internal flow filtration) will not rule out a fault but merely reduce the risk. The machine/system manufacturer must test whether remedial measures are needed on the machine for the application concerned in order to set the consumer being driven to a safe position (e.g. safe stop) and if necessary to ensure it is properly implemented.
- ▶ Moving parts in high-pressure relief valves may in certain circumstances become stuck in an undefined position due to contamination (e.g. impure hydraulic fluid). This can result in restriction or loss of the load holding function in lifting winches. The machine/system manufacturer must check whether additional measures are required on the machine for the relevant application in order to keep the load in a safe position and ensure they are properly implemented.

Bosch Rexroth Corporation
Hydraulics
8 Southchase Court
Fountain Inn, SC 29644-9018
Telephone (864) 967-2777
Facsimile (864) 962-5338
www.boschrexroth-us.com

© 2024 Bosch Rexroth Corporation

This document, as well as the data, specifications and other information set forth in it, are the exclusive property of Bosch Rexroth Corporation. It may not be reproduced or given to third parties without its consent.

The data specified above only serve to describe the product. No statements concerning a certain condition or suitability for a certain application can be derived from our information. The information given does not release the user from the obligation of own judgment and verification. It must be remembered that our products are subject to a natural process of wear and aging.

Subject to change.