

Axial piston variable pump A10VOH145 Series 60

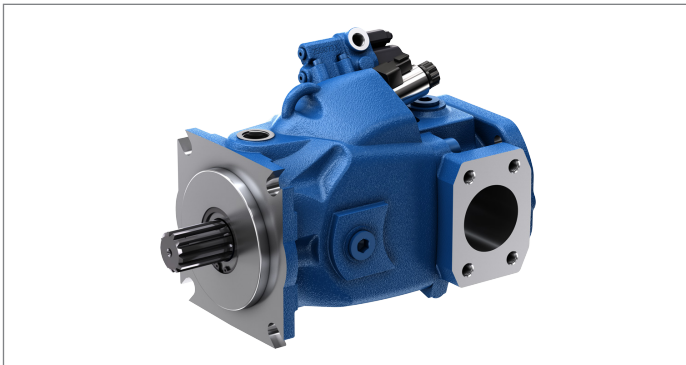

- ▶ Universal high pressure pump
- ▶ Size 145
- ▶ Nominal pressure 320 bar
- ▶ Maximum pressure 420 bar
- ▶ Open circuit

Features

- ▶ Variable pump with axial piston rotary group in swashplate design for hydrostatic drives in open circuit.
- ▶ Flow is proportional to drive speed and displacement.
- ▶ The flow can be infinitely varied by adjusting the swashplate angle.
- ▶ Nominal pressure range up to 350 bar for reduced operation data possible.
- ▶ High permissible drive speed
- ▶ Favorable power-to-weight ratio – compact dimensions
- ▶ Low noise
- ▶ Excellent suction characteristics
- ▶ Electro-proportional swivel angle control
- ▶ Short control times

Contents

Type code	2
Hydraulic fluids	5
Working pressure range	7
Technical data	8
DR0 – Pressure controller	10
DRG – Pressure controller, remotely controlled	11
DRS / DRC – pressure flow controller	12
EP – Electro-proportional control	14
Dimensions, size 145	15
Dimensions, through-drive	20
Overview of mounting options	22
Combination pumps A10VOH145 + A10VOH145	23
Connector for solenoids	24
Installation instructions	25
Project planning notes	28
Safety instructions	29

Type code

01	02	03	04	05	06	07	08	09	10	11	12	13	14	15	16	17	18	19	20	21	22
A10V	O	H	145							/	60						0		0	0	

Axial piston unit																					145
01	Swashplate design, variable																			●	A10V

Operating mode																					
02	Pump, open circuit																			●	O

Pressure range																					
03	High pressure version, nominal pressure 320 bar, maximum pressure 420 bar																			●	H

Size (NG)																					
04	Geometric displacement, see table of values on page 8																			145	

Control device: Basic controller																					145	
05	Pressure controller	Hydraulic	Fixed setting																	●	DR0	
			Remote controlled																	●	DRG	
			X-T plugged										With flushing function							●	DRS	
											Without flushing function							●	DRC			
Electro-proportional control		Positive control									$U = 12/24\text{ V}$ $I = 1500\text{ mA}$										○	EP4

Auxiliary control function pressure control (can only be combined with EP4)																					145
06	Without additional controller																			●	00
	Pressure controller	Hydraulic		Fixed setting																●	DR

Auxiliary control function flow control (load-sensing) (can only be combined with EP4)																					145	
07	Without additional controller																			●	0	
	Flow controller					X-T plugged							With flushing function							●	S	
																				Without flushing function		●

Connector for solenoids¹⁾																					145
08	Without connector (without solenoid, only for hydraulic control)																			●	0
	DEUTSCH – molded connector, 2-pin – without suppressor diode (for electric controls)																			●	P

Swivel angle sensor																					145
09	Without swivel angle sensor																			●	0
	With electric swivel angle sensor (as per data sheet 95153)										Power supply $U = 5\text{ V DC}$										●

Pressure sensor																					145
10	Without pressure sensor																			●	0

Series																					145
11	Series 6, index 0																			●	60

Version of port and fastening threads (hydraulic connections, housing and controller)																					145
12	Metric ports based on ISO 11926 with O-ring seal (ANSI), metric fastening threads according to DIN 13 at the through drive																			●	D²⁾
	Metric ports based on ISO 6149 with O-ring seal (ANSI), metric fastening threads according to DIN 13 at the through drive																			○	M²⁾

Direction of rotation																					145	
13	Viewed on drive shaft										Clockwise										●	R
											Counter-clockwise										●	L

● = Available ○ = On request

¹⁾ Connectors for other electric components may deviate
²⁾ Also applies to the version without through drive

01	02	03	04	05	06	07	08	09	10	11	12	13	14	15	16	17	18	19	20	21	22
A10V	O	H	145							/	60						0		0	0	

Sealing material		145
14	Single shaft seal ring FKM (fluorocarbon rubber), O-ring FKM (fluorocarbon rubber)	● V
	Double shaft seal FKM (fluorocarbon rubber), O-ring FKM (fluorocarbon rubber) and indicator hole	● W

Mounting flange		145	
15	Based on ISO 3019-1 (SAE J744)	127-2 (C) (with through drive, please contact us)	● C2³⁾
		152-4 (D)	● D4
	Based on SAE J617	409-12 (No.3)	● G3

Drive shaft		145	
16	Splined shaft ANSI B92.1a	1 3/4 in 13T 8/16DP	● R1
		1 3/4 in 13T 8/16DP	● T1
		1 1/2 in 17T 12/24DP	● W9
		1 3/8 in 21T 16/32DP	● W8⁴⁾

Working port		145	
17	SAE flange connections (DIN 6162), metric fastening thread	Laterally opposite	● A2
	SAE flange connections (DIN 6162), fastening thread ASME B1.1	Laterally opposite	○ B2

Port plate version		145
18	Without noise optimization	● 0

Through drive (for mounting options, see page 22)

19	Flange ISO 3019-1			Hub for splined shaft ⁵⁾			145
	Diameter	Attachment	Designation	Diameter	Designation		
	Without through drive						● N000
	101-2 (B)	●●	B2	7/8 in	13T 16/32DP	S4	● B2S4
				1 in	15T 16/32DP	S5	● B2S5
				1 1/4 in	14T 12/24DP	S7	● B2S7
		●	B5	7/8 in	13T 16/32DP	S4	● B5S4
				1 in	15T 16/32DP	S5	● B5S5
				1 1/4 in	14T 12/24DP	S7	● B5S7
	●	B7	7/8 in	13T 16/32DP	S4	● B7S4	
			1 in	15T 16/32DP	S5	● B7S5	
			1 1/4 in	14T 12/24DP	S7	● B7S7	
	127-2 (C)	●●	C2	1 1/4 in	14T 12/24DP	S7	● C2S7
				1 1/2 in	17T 12/24DP	S9	● C2S9
				1 1/4 in	14T 12/24DP	S7	● C5S7
●		C5	1 1/2 in	17T 12/24DP	S9	● C5S9	
			1 1/4 in	14T 12/24DP	S7	● C7S7	
			1 1/2 in	17T 12/24DP	S9	● C7S9	
152-4 (D)	●●	D4	1 3/4 in	13T 8/16DP	T1	● D4T1	

● = Available ○ = On request

3) Comply with notes regarding the combination pump on page 22
4) Cannot be combined with "shaft seal ring" position 13.
5) In accordance with ANSI B92.1a

4 **A10VOH145** | Axial piston variable pump
Type code

01	02	03	04	05	06	07	08	09	10	11	12	13	14	15	16	17	18	19	20	21	22
A10V	O	H	145							/	60						0		0	0	

Reduction of the geometric displacement $V_{g \min}$ and $V_{g \max}$ **145**

20	Displacement: $V_{g \min} = 0 \text{ cm}^3, V_{g \max} = V_{g \max}$	●	0
----	--	---	---

Other sensors **145**

21	Without sensors	●	0
----	-----------------	---	---

Standard/special version **145**

22	Standard version	●	0
	Special version	●	S

● = Available ○ = On request

Notice

- ▶ Note the project planning notes on page 28.
- ▶ Observe the project planning notes regarding each control device
- ▶ In addition to the type code, please specify the relevant technical data when placing your order.

Hydraulic fluids

The variable pump A10VOH145 is designed for operation with HLP mineral oil according to DIN 51524.

See the following data sheets for application instructions and requirements for hydraulic fluids before the start of project planning:

- ▶ 90220: Hydraulic fluids based on mineral oils and related hydrocarbons

Selection of hydraulic fluid

Bosch Rexroth evaluates hydraulic fluids on the basis of the Fluid Rating according to the technical data sheet 90235.

Hydraulic fluids with positive evaluation in the Fluid Rating are provided in the following technical data sheet:

- ▶ 90245: Bosch Rexroth Fluid Rating List for Rexroth hydraulic components (pumps and motors)

The hydraulic fluid should be selected so that the operating viscosity in the operating temperature range is within the optimum range (v_{opt} ; see selection diagram).

Viscosity and temperature of hydraulic fluids

	Viscosity	Shaft seal	Temperature ²⁾	Remarks
Cold start	$v_{max} \leq 1600 \text{ mm}^2/\text{s}$	FKM	$\vartheta_{St} \geq -25 \text{ }^\circ\text{C}$	$t \leq 3 \text{ min}$, without load ($p \leq 50 \text{ bar}$), $n \leq 1000 \text{ rpm}$ Permissible temperature difference between axial piston unit and hydraulic fluid in the system maximum 25 K
Warm-up phase	$v = 1600 \dots 400 \text{ mm}^2/\text{s}$			$t \leq 15 \text{ min}$, $p \leq 0.7 \times p_{nom}$ and $n \leq 0.5 \times n_{nom}$
Continuous operation	$v = 400 \dots 10 \text{ mm}^2/\text{s}^{1)}$ $v_{opt} = 36 \dots 16 \text{ mm}^2/\text{s}$	FKM	$\vartheta \leq +110 \text{ }^\circ\text{C}$	Measured at port L_x Optimal operating viscosity and efficiency range
Short-term operation	$v_{min} = 10 \dots 7 \text{ mm}^2/\text{s}$	FKM		$t \leq 3 \text{ min}$, $p \leq 0.3 \times p_{nom}$, measured at port L_x

▼ Selection diagram

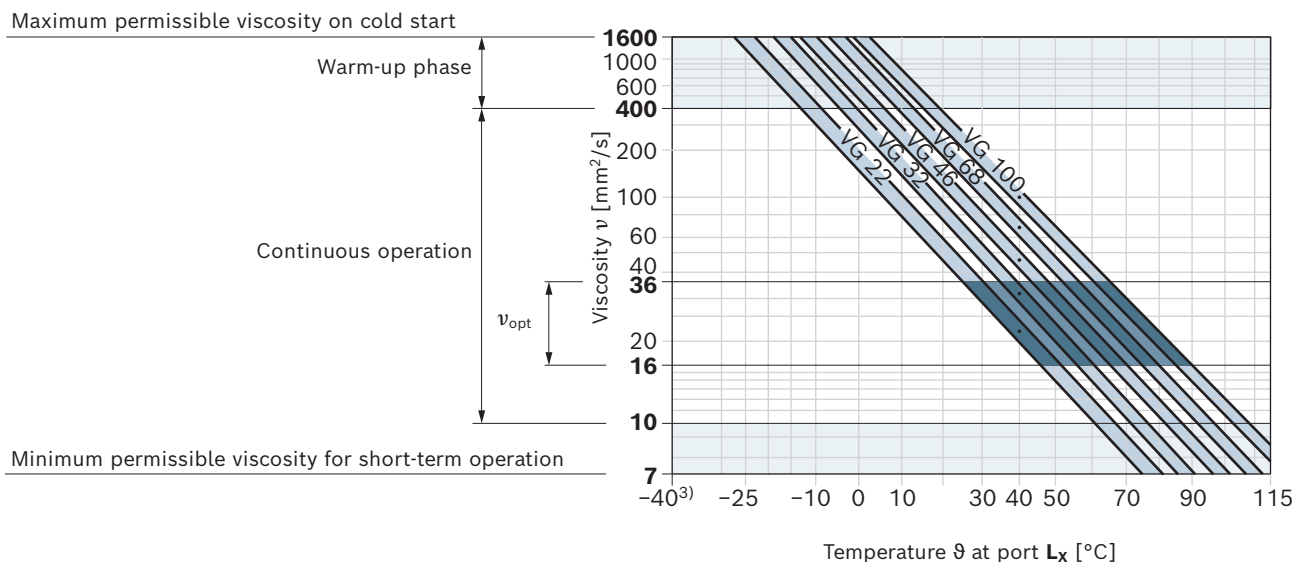

1) This corresponds, for example on the VG 46, to a temperature range of +4 °C to +85 °C (see selection diagram)

2) If the temperature at extreme operating parameters cannot be adhered to, please contact us.

3) For applications in the low-temperature range, please contact us.

Filtration of the hydraulic fluid

Finer filtration improves the cleanliness level of the hydraulic fluid, which increases the service life of the axial piston unit.

A cleanliness level of at least 20/18/15 is to be maintained according to ISO 4406

At a hydraulic fluid viscosity of less than 10 mm²/s (e.g. due to high temperatures during short-term operation) at the drain port, a cleanliness level of at least 19/17/14 according to ISO 4406 is required.

For example, a viscosity of 10 mm²/s corresponds to the following temperatures with the following media:

- ▶ a temperature of 73 °C for HLP 32
- ▶ a temperature of 85 °C for HLP 46

Working pressure range

Pressure at port B		Definition
Nominal pressure p_{nom}	320 bar	The nominal pressure corresponds to the maximum design pressure.
"Load Cycle (LC)" nominal pressure $p_{nom, LC}$	350 bar	Permissible only up to 80% swivel angle and 2000 rpm.
Maximum pressure p_{max}	420 bar	The maximum pressure corresponds to the maximum working pressure within a single operating period. The sum of the single operating periods must not exceed the total operating period (maximum number of cycles: approx. 1 million).
Single operating period	0,05 s	
Total operating period	14 h	
Minimum pressure $p_{B abs}$ (high-pressure side)	10 bar	Minimum pressure on the high-pressure side (B) which is required in order to prevent damage to the axial piston unit.
Rate of pressure change $R_{A max}$	16000 bar/s	Maximum permissible speed of pressure build-up and reduction during a pressure change across the entire pressure range.
Pressure at suction port S (inlet)		
Minimum pressure $p_{S min}$	0.8 bar absolute	Minimum pressure at suction port S (inlet) which is required to prevent damage to the axial piston unit. The minimum pressure depends on the rotational speed, pressure on the port B and displacement of the axial piston unit.
Maximum pressure $p_{S max}$	5 bar absolute	
Case pressure at port L ₁ , L ₂		
Maximum pressure $p_{L max}$	2 bar ¹⁾	Maximum 0.5 bar higher than inlet pressure at port S , but not higher than $p_{L max}$. A drain line to the reservoir is required.
Pilot pressure port X with external high pressure		
Maximum pressure p_{max}	420 bar	When designing all control lines with external high pressure, the values for the rate of pressure change, maximum single operating period and total operating period applicable to port B must not be exceeded.

▼ Rate of pressure change $R_{A max}$

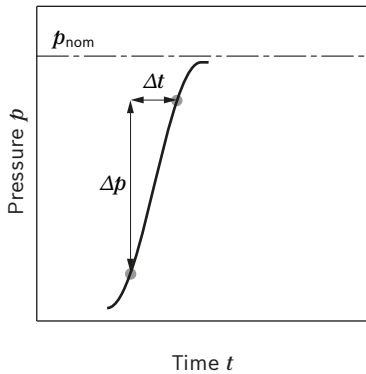

▼ Pressure definition

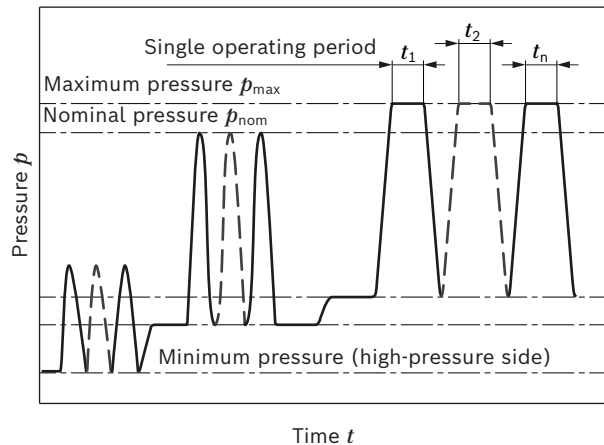

$$\text{Total operating period} = t_1 + t_2 + \dots + t_n$$

Notice

Working pressure range applies when using hydraulic fluids based on mineral oils. Please contact us for values for other hydraulic fluids.

1) Higher housing pressures on request

Technical data

Size		NG		145
Geometric displacement, per revolution		$V_{g \max}$	cm ³	145
Maximum rotational speed ¹⁾	at $V_{g \max}$	n_{nom}	rpm	2300
Flow	at n_{nom} and $V_{g \max}$	q_v	l/min	333
	at $n_E = 1500$ rpm	q_{vE}	l/min	217
Power	at n_{nom} , $V_{g \max}$ and $\Delta p = 320$ bar	P	kW	178
	at $n_E = 1500$ rpm, $V_{g \max}$ and $\Delta p = 320$ bar	P_E	kW	116
Torque	at $V_{g \max}$ and $\Delta p = 320$ bar	M	Nm	738
Rotary stiffness	R1	c	Nm/rad	151084
Drive shaft	T1	c	Nm/rad	144252
	W9	c	Nm/rad	137475
	W8	c	Nm/rad	141257
Moment of inertia of the rotary group		J_{TW}	kgm ²	0.016
Maximum angular acceleration ²⁾		α	rad/s ²	2700
Case volume		V	l	1.3
Weight approx.				
Mounting flange	Through drive			
C2/D4	Without	m	kg	57
	With	m	kg	62
G3	Without	m	kg	72
	With	m	kg	77

Determination of the operating characteristics				
Flow	q_v	$= \frac{V_g \times n \times \eta_v}{1000}$		[l/min]
Torque	M	$= \frac{V_g \times \Delta p}{20 \times \pi \times \eta_{\text{hm}}}$		[Nm]
Power	P	$= \frac{2 \pi \times M \times n}{60000} = \frac{q_v \times \Delta p}{600 \times \eta_t}$		[kW]

Key

- V_g Displacement per revolution [cm³]
- Δp Differential pressure [bar]
- n Rotational speed [rpm]
- η_v Volumetric efficiency
- η_{hm} Hydraulic-mechanical efficiency
- η_t Total efficiency ($\eta_t = \eta_v \times \eta_{\text{hm}}$)

Notice

- Theoretical values, without efficiency and tolerances; values rounded
- Operation above the maximum values or below the minimum values may result in a loss of function, a reduced service life or in the destruction of the axial piston unit. Bosch Rexroth recommends checking the load by means of test or calculation / simulation and comparison with the permissible values.

1) The values are applicable:
 – at an absolute pressure $p_{\text{abs}} = 1$ bar at the suction port **S**
 – for the optimum viscosity range from $\nu_{\text{opt}} = 36$ to 16 mm²/s
 – with hydraulic fluid based on mineral oils
 Higher rotational speeds on request

2) The data are valid for values between the minimum required and maximum permissible rotational speed. Valid for external excitation (e.g. diesel engine 2 to 8 times the rotary frequency; cardan shaft 2 times the rotary frequency). The limit value is only valid for a single pump. The load capacity of the connection parts must be considered.

Permissible radial and axial loading of the drive shaft

Notice

- ▶ For drives with radial loading (pinions, V-belt drives), please contact us!
- ▶ For drives with axial loading drives, please contact us!

Permissible inlet and through-drive torques

Size	145		
Torque at $V_{g\ max}$ and $\Delta p = 320\ \text{bar}^1$	M_{\max}	Nm	738
Maximum input torque on drive shaft ²⁾			
R1	$M_{E\ \max}$	Nm	2000
	\varnothing	in	1 3/4
T1	$M_{E\ \max}$	Nm	1640
	\varnothing	in	1 3/4
W9	$M_{E\ \max}$	Nm	1320
	\varnothing	in	1 1/2
W8	$M_{E\ \max}$	Nm	1295
	\varnothing	in	1 3/8
Through-drive torque, maximum ¹⁾			
R1	$M_{D\ \max}$	Nm	770
W9	$M_{D\ \max}$	Nm	770
W8	$M_{D\ \max}$	Nm	770

▼ Distribution of torques

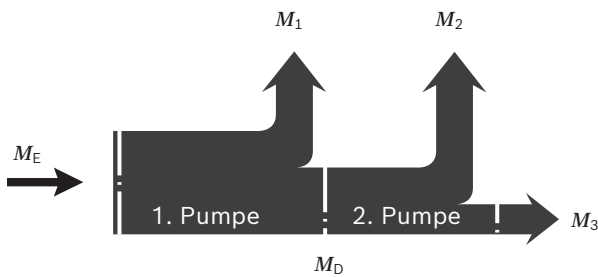

Drehmoment 1. Pumpe	M_1
Drehmoment 2. Pumpe	M_2
Drehmoment 3. Pumpe	M_3
Eingangsdrehmoment	$M_E = M_1 + M_2 + M_3$
	$M_E < M_{E\ \max}$
Duchtriebsdrehmoment	$M_D = M_2 + M_3$
	$M_D < M_{D\ \max}$

1) Efficiency not considered
 2) For drive shafts with no radial force

DR0 – Pressure controller

The pressure controller limits the maximum pressure at the pump outlet within the control range of the variable pump. The variable pump only supplies as much hydraulic fluid as is required by the consumers. If the working pressure exceeds the pressure command value at the pressure valve, the pump will regulate to a smaller displacement to reduce the control differential.

- ▶ Basic position in depressurized state: $V_{g \max}$.
- ▶ Setting range¹⁾ for pressure control 80 to 320 bar. Standard is 320 bar.
- ▶ Setting up to 350 bar for reduced operation data possible

▼ Characteristic curve DR0

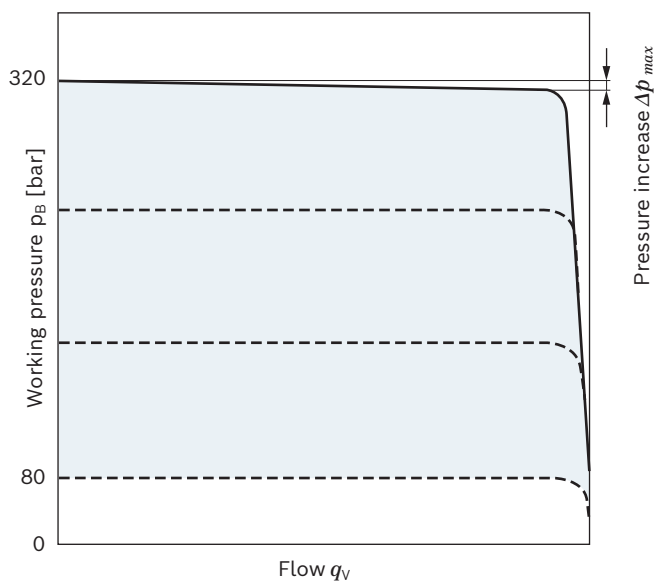

Characteristic curve valid for $n_1 = 1500$ rpm and $t_{fluid} = 50$ °C.

▼ Circuit diagram DR0

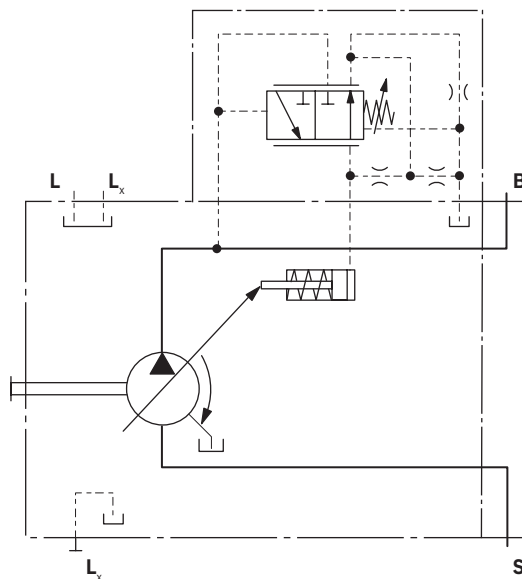

Controller data

Size	145
Pressure increase Δp [bar]	Maximum 14
Hysteresis and repeatability Δp [bar]	Maximum 8

¹⁾ In order to prevent damage to the pump and the system, the permissible setting range must not be exceeded. The range of possible settings at the valve is higher.

DRG – Pressure controller, remotely controlled

For the remote controlled pressure controller, the LS pressure limitation is performed using a separately arranged pressure relief valve. Therefore, any pressure control value under the pressure set on the pressure controller can be regulated. Pressure controller DR0 see page 10.

A pressure relief valve is externally piped up to port **X** for remote control. This relief valve is not included in the scope of delivery of the DRG control.

When there is differential pressure Δp at the control valve and with the standard setting on the remote controlled pressure cut-off of 20 bar, the amount of control fluid at the port is **X** approx. 1.5 l/min. If a different setting (range 10 to 22 bar) is required, please state in plain text.

As a separate pressure relief valve (1) we recommend:

- ▶ A direct operated, hydraulic or electric proportional one, suitable for the control fluid mentioned above.

The maximum line length should not exceed 2 m.

- ▶ Basic position in depressurized state: $V_{g \max}$.
- ▶ Setting range¹⁾ for pressure control 80 to 320 bar (3). Standard is 320 bar.
- ▶ Setting range for differential pressure 10 up to 22 bar (2). Standard is 20 bar.

Unloading port **X** to the reservoir results in a zero stroke pressure (standby) which is approx. 1 to 2 bar higher than the defined differential pressure Δp , however system influences are not taken into account.

▼ Characteristic curve DRG

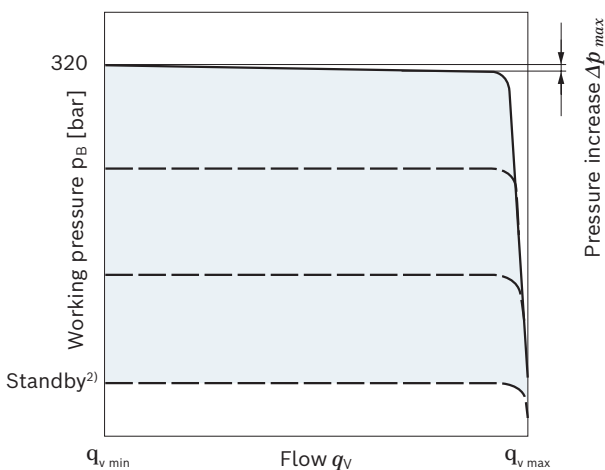

Characteristic curve valid for $n_1 = 1500$ rpm and $t_{fluid} = 50$ °C.

▼ Circuit diagram DRG

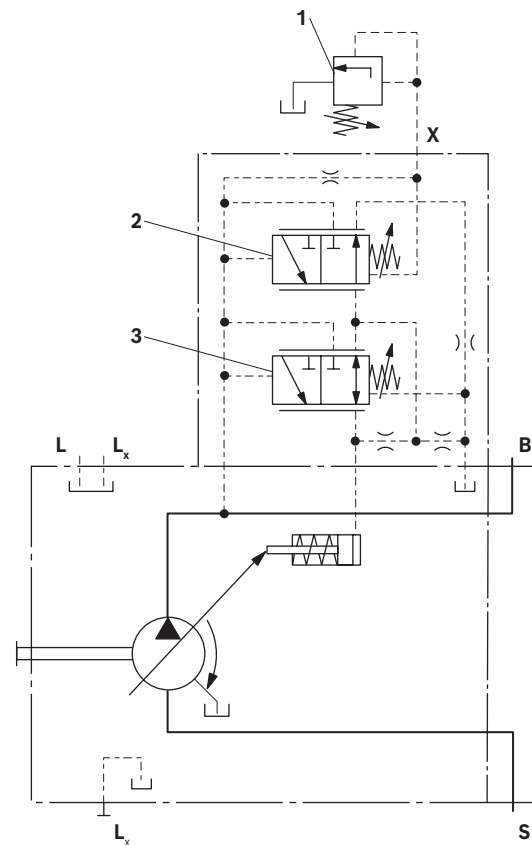

- 1 The separate pressure relief valve and the line are not included in the scope of delivery.
- 2 Remote controlled pressure cut-off (G)
- 3 Pressure controller (DR)

Controller data

Size	145	
Pressure increase	Δp [bar]	Maximum 14
Hysteresis and repeatability	Δp [bar]	Maximum 8
Pilot fluid consumption	l/min	Maximum approx. 4.5

1) In order to prevent damage to the pump and the system, the permissible setting range must not be exceeded. The range of possible settings at the valve is higher.

2) Zero stroke pressure from pressure setting Δp on controller (2)

DRS / DRC – pressure flow controller

In addition to the pressure controller function (see page 10), an adjustable orifice (e.g. directional valve) is used to adjust the differential pressure upstream and downstream of the orifice. This is used to control the pump flow. The pump flow is equal to the actual hydraulic fluid quantity required by the consumer. With all controller combinations, the V_g reduction has priority.

- ▶ Basic position in depressurized state: $V_{g \max}$.
- ▶ Setting range¹⁾ to 320 bar.
- ▶ Pressure controller DR0 data see page 10.

▼ Characteristic curve DRS / DRC

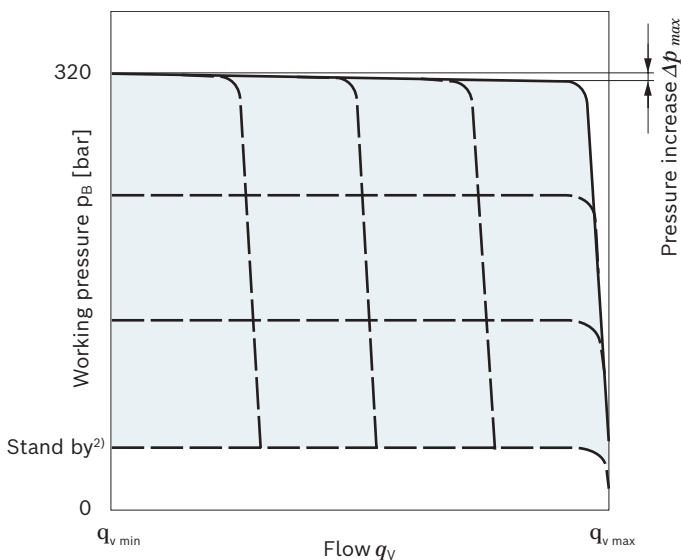

▼ Characteristic curve at variable rotational speed

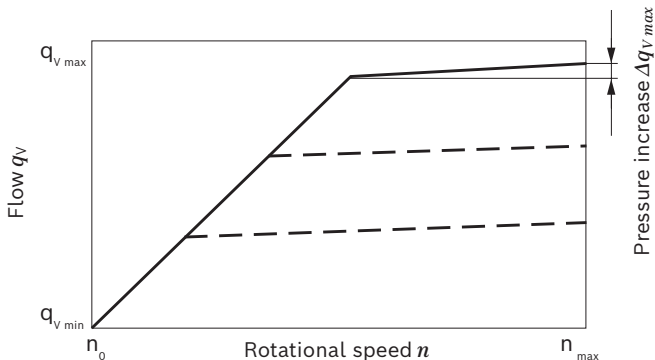

Characteristic curves valid for $n_1 = 1500$ rpm and $t_{\text{fluid}} = 50$ °C.

- 1) In order to prevent damage to the pump and the system, the permissible setting range must not be exceeded. The range of possible settings at the valve is higher.
- 2) Zero stroke pressure from differential pressure setting Δp on controller (2)

Possible connections at port **B**
(not included in the scope of delivery)

LS mobile control blocks	Data sheets
M4-12	64276
M4-15	64283
LUDV mobile control blocks	
M7-22	64295

▼ Circuit diagram DRS / DRC

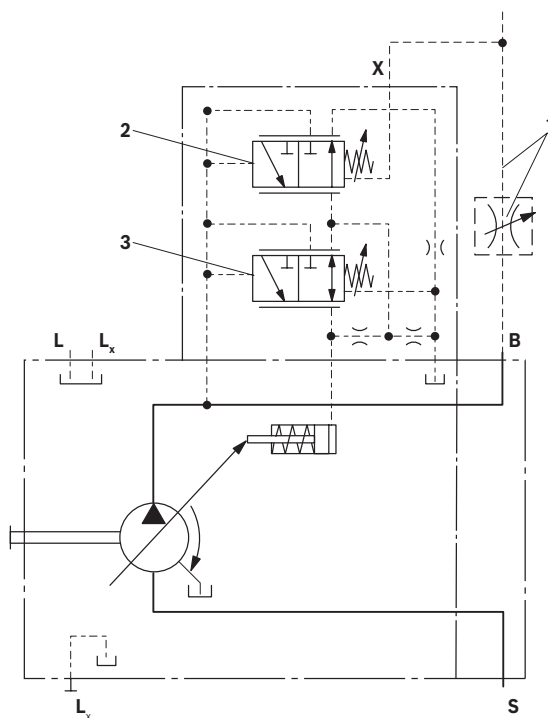

- 1 The metering orifice (control block) and the line is not included in the scope of delivery.
- 2 Flow controller (**S** or **C**).
- 3 Pressure controller (**DR**)

Notice

The DRS and DRC versions have no unloading from **X** to the reservoir.
The LS must thus be unloaded in the system.
Because of the flushing function of the flow controller in the DRS control valve, sufficient unloading of the **X** line must also be ensured.
If this unloading of the **X** line cannot be ensured, the DRC control valve must be used.

For further information see page 13

Differential pressure Δp :

- ▶ Standard setting: 14 bar
 If another setting is required, please state in clear text.
- ▶ Setting range: 14 bar to 22 bar

Unloading port **X** to the reservoir results in a zero stroke pressure (standby) which is approx. 1 to 2 bar higher than the defined differential pressure Δp , however system influences are not taken into account.

Controller data

- ▶ Pressure controller DR0 data see page 10.
- ▶ Maximum flow deviation measured at drive speed
 n = 1500 rpm.

Size		145
Flow deviation	Δq_{vmax} [l/min]	8
Hysteresis; repeatability	Δp [bar]	Maximum 4
Pilot fluid consumption	l/min	Maximum approx. 3

EP – Electro-proportional control

Electro proportional control makes a continuous and reproducible setting of the pump displacement possible directly via the cradle. The control force of the control piston is applied by a proportional solenoid. The control is proportional to the current (for start of control, see table right).

In a depressurized state, the pump is swiveled to its initial position ($V_{g \max}$) by an adjusting spring. If the working pressure exceeds approx. 4 bar, the pump starts to swivel from $V_{g \max}$ to $V_{g \min}$ without control by the solenoid (control current < start of control). With a minimum swivel angle $V_{g \min}$ and de-energized EP solenoids, a minimum pressure of 10 bar must be maintained.

A PWM or Dither signal is used to control the solenoid. A minimum working pressure of 30 bar is needed for safe and reproducible control. The required control fluid is taken from the high pressure.

EP.DR: The pressure control regulates the pump displacement back to $V_{g \min}$ after the pressure command value has been reached.

▼ Characteristic curve EP4

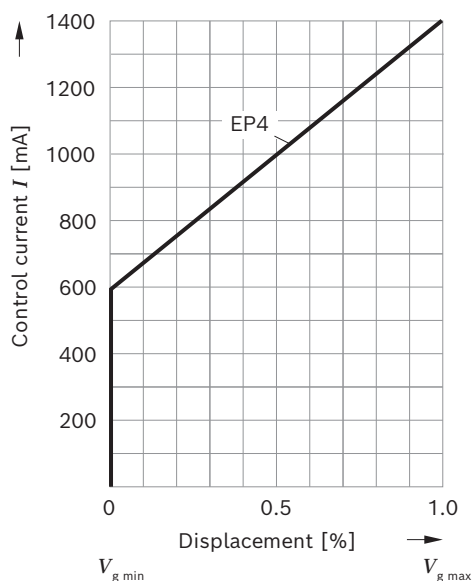

- Hysteresis static current-displacement characteristic curve < 10%.

▼ Circuit diagram EP.DR

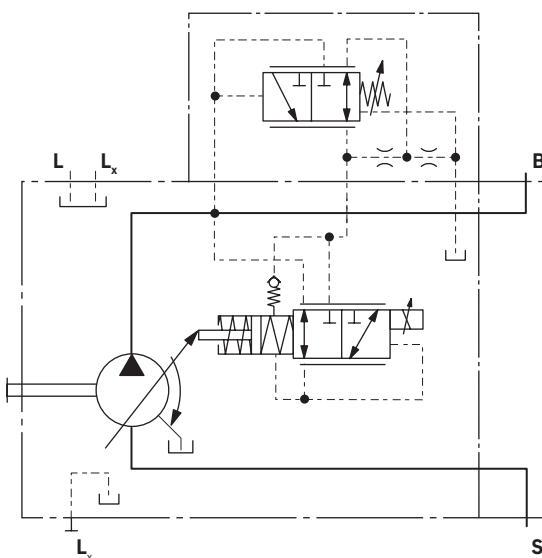

Technical data, solenoids	EP4
Voltage	12/24 V (±20%)
Control current	
Start of control at $V_{g \min}$	600 mA
End of control at $V_{g \max}$	1400 mA
Dither frequency	100 Hz
Recommended amplitude	120 mA
Current limit	1500 mA
Nominal resistance (at 20 °C)	4,26 Ω
Duty cycle	100%
Type of protection: see connector version page 24	
Operating temperature range at valve -20 °C to +115 °C	

The following electronic control units and amplifiers are available for controlling the proportional solenoids:

BODAS Steuergeräte	Datenblatt
RC5-6 Baureihe 40	95207
RC18-12 Baureihe 40	95208
RC27-18 Baureihe 40	95208

Dimensions, size 145

DRC – Pressure flow controller, clockwise rotation, mounting flange C2 (SAE-C; 127-2)¹⁾

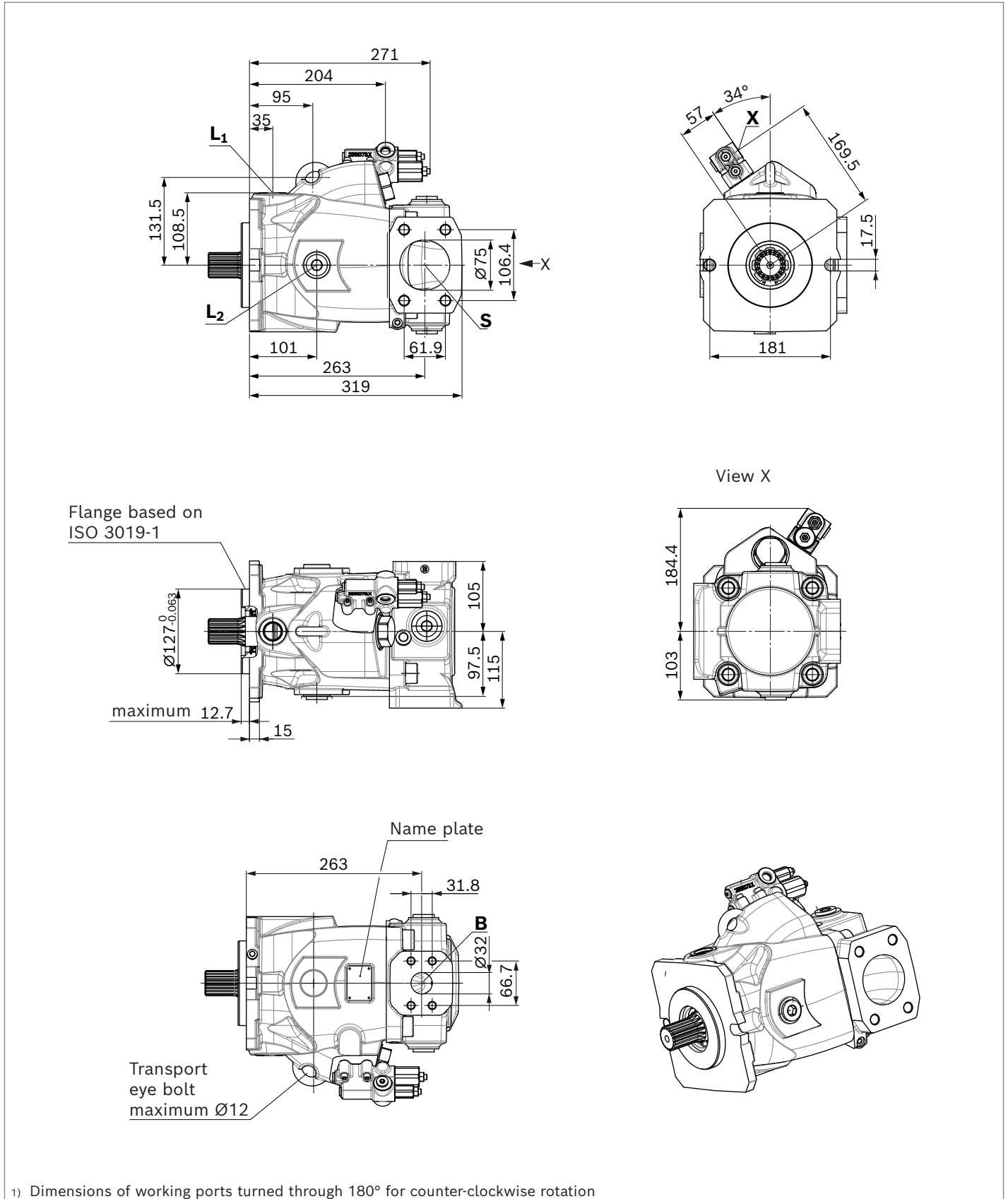

Dimensions, size 145

DRC - Pressure flow controller, clockwise rotation, mounting flange D4 (SAE-D; 152-4)¹⁾

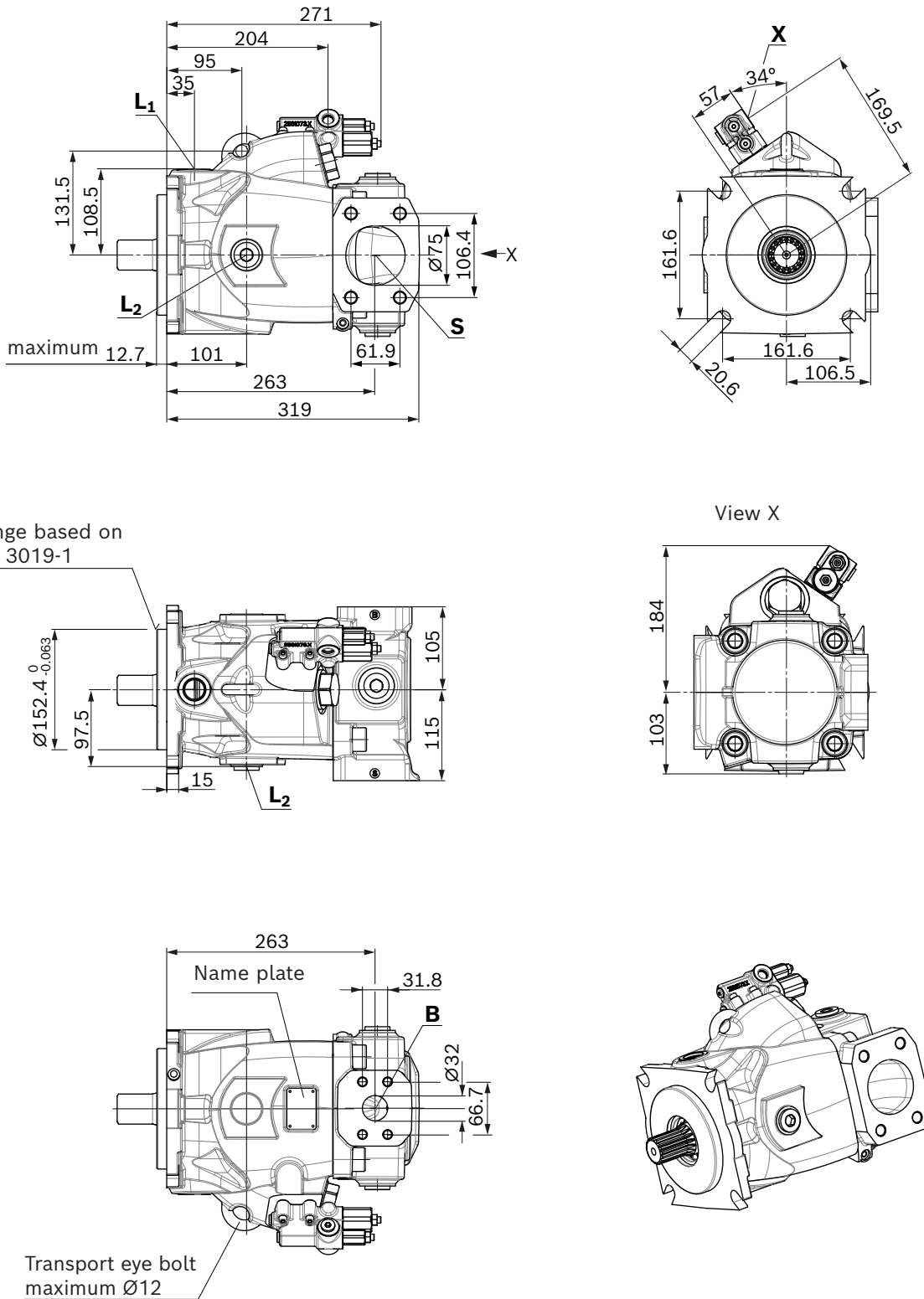

¹⁾ Dimensions of working ports turned through 180° for counter-clockwise rotation

Dimensions, size 145

EP4DR – electro proportional control with pressure controller, clockwise rotation, mounting flange G3 (SAE J617)¹⁾

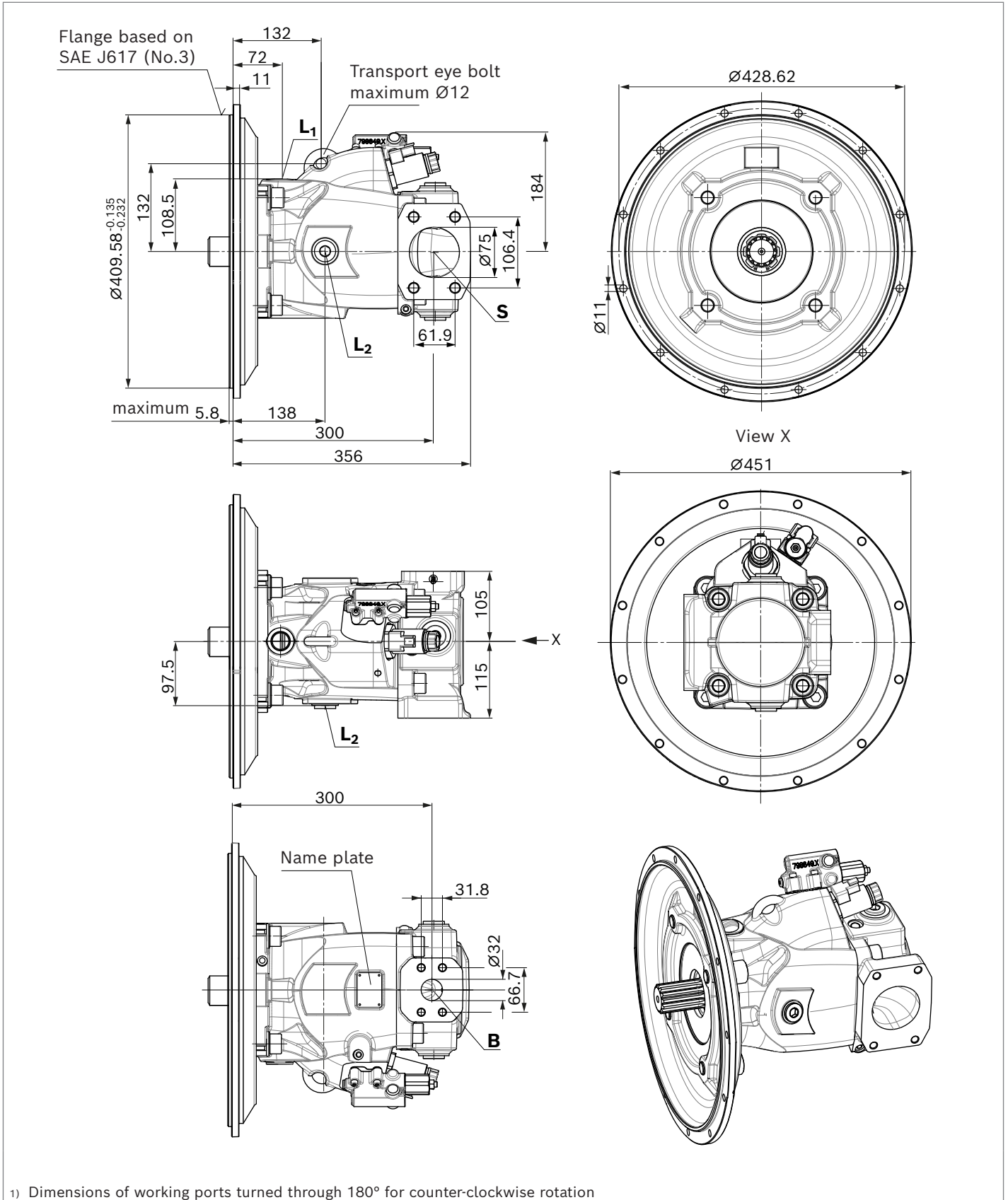

▼ **Splined shaft 1 3/4 in** (similar 44-4, ISO 3019-1)

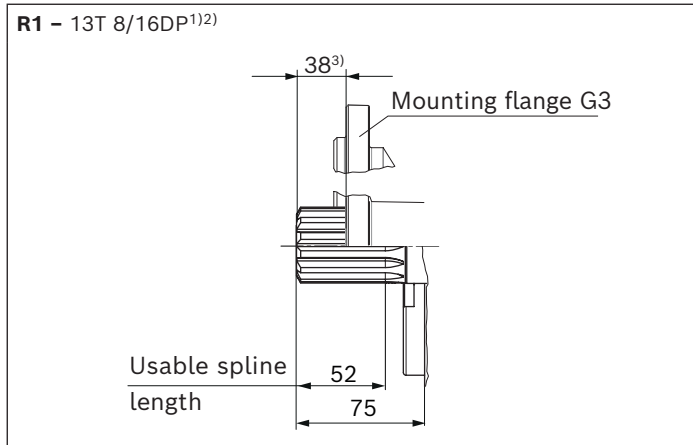

▼ **Splined shaft 1 1/2 in** (similar 38-4, ISO 3019-1)

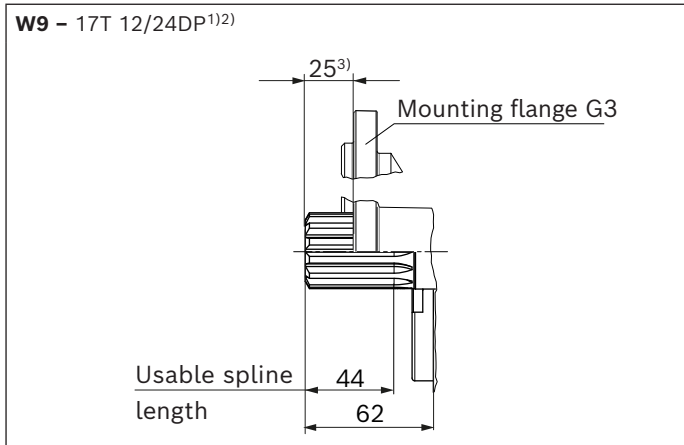

▼ **Splined shaft 1 3/4 in** (44-4, ISO 3019-1)

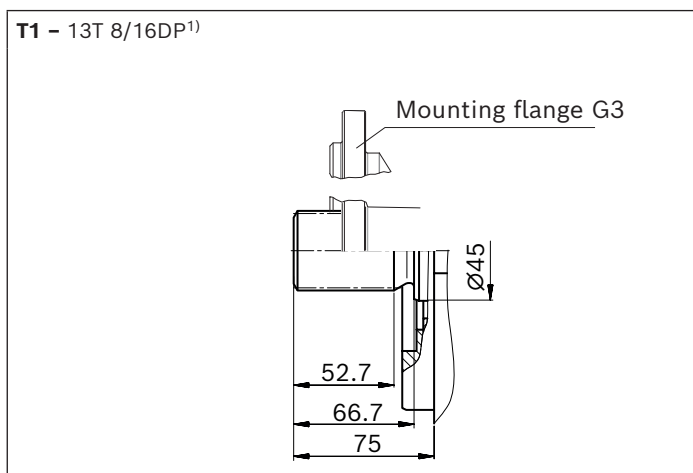

▼ **Splined shaft 1 3/8 in** (similar 35-4, ISO 3019-1)

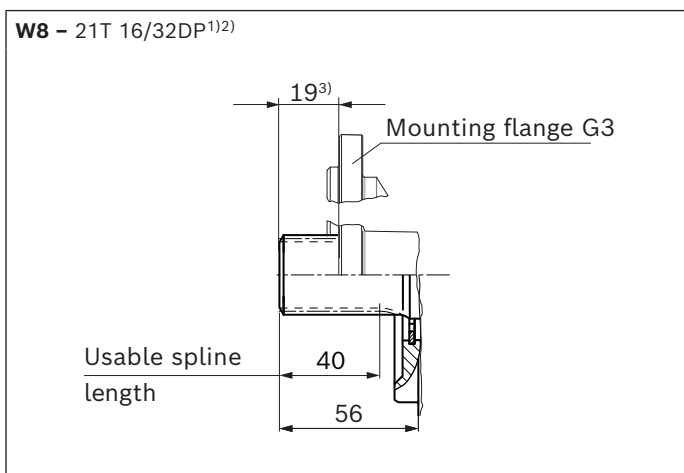

Ports	Standard	Size	p_{\max} [bar] ⁴⁾	State ⁸⁾
B Working port (high-pressure series) Fastening thread	SAE J518 ⁵⁾ DIN 13	1 1/4 in M12 × 1.75; 21 deep	420	O
S Suction port (standard pressure series) Fastening thread	SAE J518 ⁵⁾ DIN 13	3 in M16 × 2; 24 deep	5	O
L₁ Drain port	based on ISO 11926 ⁶⁾	1 1/16-12UN-2B; 20 deep	2	O ⁷⁾
L₂ Drain port	based on ISO 11926 ⁶⁾	1 1/16-12UN-2B; 20 deep	2	X ⁷⁾
X Pilot pressure	based on ISO 11926	9/16-18UNF-2B; 13 deep	420	O

1) Involute spline according to ANSI B92.1a, 30° pressure angle, flat root, side fit, tolerance class 5
 2) Spline runout is a deviation from standard SAE J744.
 3) For version with mounting flange G3.
 4) Depending on the application, momentary pressure peaks can occur. Keep this in mind when selecting measuring devices and fittings.
 5) Metric fastening thread is a deviation from standard.

6) The countersink may be deeper than specified in the standard.
 7) Depending on the installation position, **L₁** or **L₂** must be connected (also see installation instructions starting on page 25).
 8) O = Must be connected (plugged on delivery)
 X = Plugged (in normal operation)

Port plate A2; mounting flange D4

▼ **DR0 - Pressure controller**

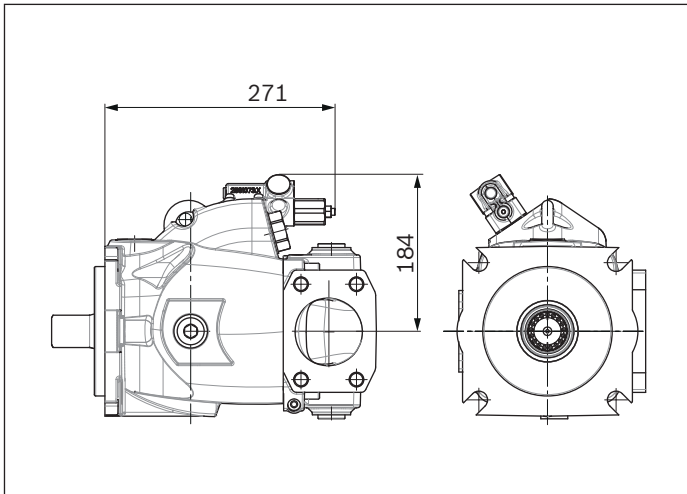

▼ **DRC - Pressure flow controller**

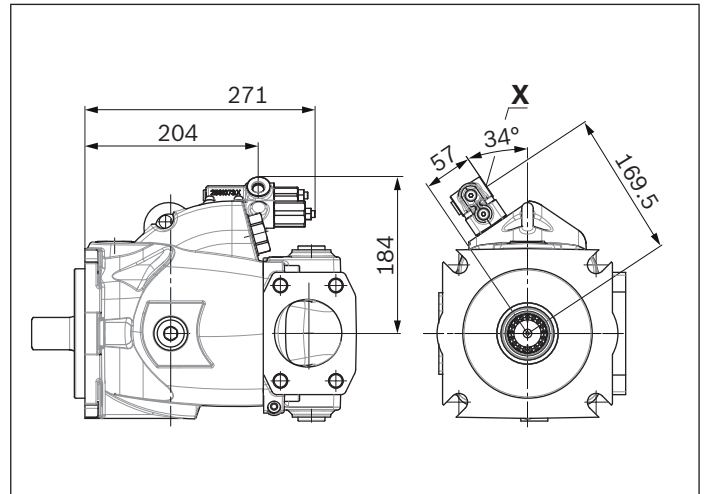

▼ **EP4DR - Electro-proportional control with pressure controller**

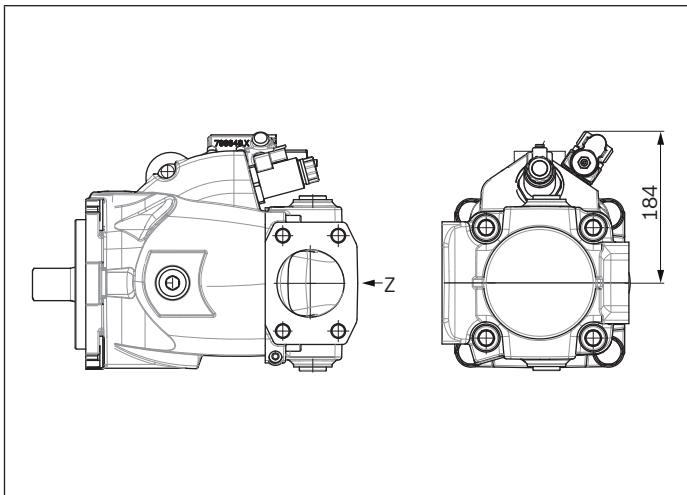

Dimensions, through-drive

Flange ISO 3019-1 (SAE)			Hub for splined shaft ¹⁾			Availability across sizes	Code
Diameter	Mounting ²⁾	Designation	Diameter		Designation	145	
101-2 (B)	↔	B2	7/8 in	13T 16/32DP	S4	●	B2S4
			1 in	15T 16/32DP	S5	●	B2S5
			1 1/4 in	14T 12/24DP	S7	●	B2S7
	↗	B5	7/8 in	13T 16/32DP	S4	●	B5S4
			1 in	15T 16/32DP	S5	●	B5S5
			1 1/4 in	14T 12/24DP	S7	●	B5S7
	↘	B7	7/8 in	13T 16/32DP	S4	●	B7S4
			1 in	15T 16/32DP	S5	●	B7S5
			1 1/4 in	14T 12/24DP	S7	●	B7S7

● = Available ○ = On request

▼ 101-2³⁾

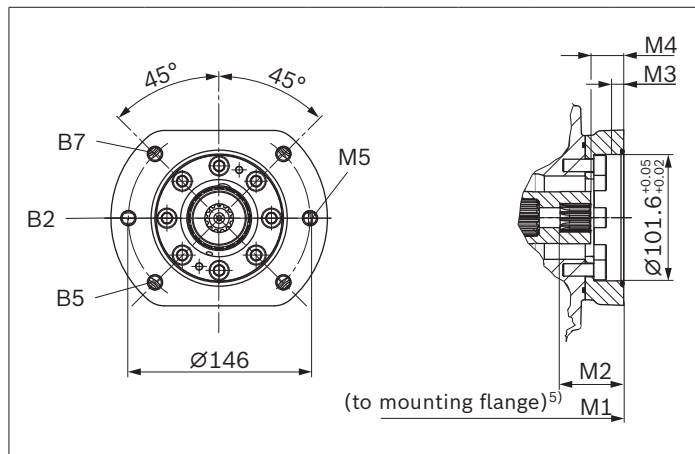

BxS4	NG	M1	M2 ⁶⁾	M3 ⁶⁾	M4 ⁶⁾	M5 ⁴⁾
(22-4 (B))	145	334.5	44.6	10	20.3	M12; 20 deep
BxS5	NG	M1	M2	M3	M4	M5 ⁴⁾
25-4(B-B))	145	334.5	49.3	10	20.5	M12; 20 deep
BxS7	NG	M1	M2	M3	M4	M5 ⁴⁾
(32-4 (C))	145	334.5	59.8	10	21.8	M12; 20 deep

1) According to ANSI B92.1a, 30° pressure angle, flat root, side fit, tolerance class 5

2) Mounting holes pattern viewed on through drive with control at top

3) According to SAE J744

4) Thread according to DIN 13

5) 37 mm longer for version with mounting flange G3

6) Minimum dimensions

Flange ISO 3019-1 (SAE)			Hub for splined shaft ¹⁾		Availability across sizes	Code
Diameter	Mounting ²⁾	Designation	Diameter	Designation	145	
127-2 (C)	☺	C2	1 1/4 in 14T 12/24DP	S7	●	C2S7
			1 1/2 in 17T 12/24DP	S9	●	C2S9
	☻	C5	1 1/4 in 14T 12/24DP	S7	●	C5S7
			1 1/2 in 17T 12/24DP	S9	●	C5S9
	☼	C7	1 1/4 in 14T 12/24DP	S7	●	C7S7
			1 1/2 in 17T 12/24DP	S9	●	C7S9
152-4 (C)	☼	D4	1 3/4 in 13T 8/16DP	T1	●	D4T1

● = Available ○ = On request

▼ **127-2³⁾**

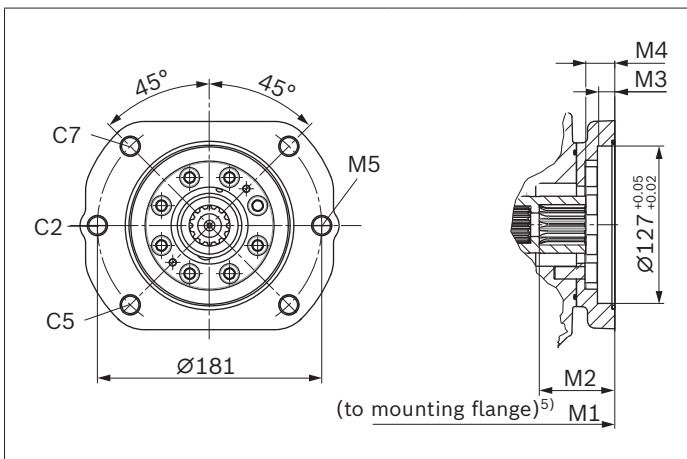

CxS7	NG	M1	M2 ⁶⁾	M3 ⁶⁾	M4 ⁶⁾	M5 ⁴⁾
(32-4 (C))	145	334.5	59.8	13	21.8	M16; 22 deep
CxS9	NG	M1	M2	M3	M4	M5 ⁴⁾
(38-4 (C-C))	145	334.5	65.3	13	23.3	M16; 22 deep

▼ **152-4³⁾**

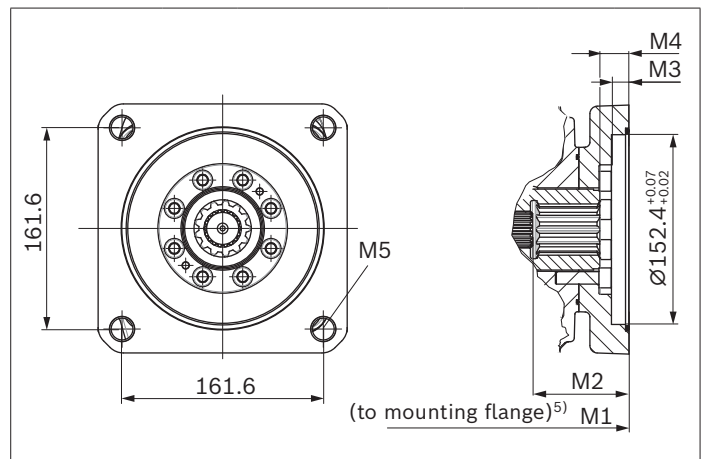

D4T1	NG	M1	M2 ⁶⁾	M3 ⁶⁾	M4 ⁶⁾	M5 ⁴⁾
(44-4 (D&E))	145	343.8	76.7	13	22.4	M20; by

1) According to ANSI B92.1a, 30° pressure angle, flat root, side fit, tolerance class 5

2) Mounting holes pattern viewed on through drive with control at top

3) According to SAE J744

4) Thread according to DIN 13

5) 37 mm longer for version with mounting flange G3

6) Minimum dimensions

Overview of mounting options

Through drive		Mounting options – 2nd pump					
Flange ISO 3019-1	Hub for splined shaft	Code	A10VOH/60 NG (shaft)	A10V(S)O/5x NG (shaft)	A10VO/3x NG (shaft)	A1VO/10 NG (shaft)	External gear pump
101-2 (B)	7/8 in	B2S4 B5S4 B7S4	–	28 (S, R) 45 (U, W)	28 (S, R) 45 (U, W)	35 (S4)	AZPN/AZPG
	1 in	B2S5 B5S5 B7S5	–	45 (S, R) 60, 63 (U, W) 72 (U, W)	45 (S, R)	35 (S5)	–
	1 1/4 in	B2S7 B5S7 B7S7	–	60, 63 (S, R) 72 (S, R)	–	–	–
127-2 (C)	1 1/4 in	C2S7 C5S7 C7S7	–	85 (U) 100 (U)	71, 88 (S, R) 100 (U, W)	–	–
	1 1/2 in	C2S9 C5S9 C7S9	145 (W9)	85 (S) 100 (S)	100 (S)	–	–
152-4 (D)	1 3/4 in	D4T1	145 (T1)	–	140 (S) 180 (S)	–	–

Notice

- ▶ A10VOH may only be planned as pump compensation without support with 100% through drive if the 1st pump is generally equipped with a 152-4 or 409-12 mounting flange (type code designation D4 or G3).

Combination pumps A10VOH145 + A10VOH145

By using combination pumps, it is possible to have independent circuits without the need for splitter gearboxes. When ordering combination pumps the type designations for the first and the second pump must be joined by a "+" and are combined into one part number. Each single pump should be ordered according to type code.

Notice

- ▶ The combination pump type code is shown in shortened form in the order confirmation.

Example:

A10VOH 145 DRS00/60BR+A10VOH 145 DRS00/60BR

- ▶ Each through drive is plugged with a **non-pressure-resistant** cover. This means the units must be sealed with a pressure-resistant cover before commissioning. Through drives can also be ordered with a pressure-resistant cover (U000).

Order example:

**A10VOH145DRC0/60BRVD4R112D4R1+
 A10VOH145DRC0/60BRVD4R112U000**

A tandem pump, with two pumps of equal size, is permissible without additional supports, assuming that the dynamic mass acceleration does not exceed maximum 10 g (= 98.1 m/s²).

For combination pumps consisting of more than two pumps, the mounting flange must be rated for the permissible mass torque (please contact us).

Notice

- ▶ Also here, A10VOH145 may only be planned as pump compensation if the 1st pump is generally equipped with a 152-4 or 409-12 mounting flange (type code designation D4 or G3).

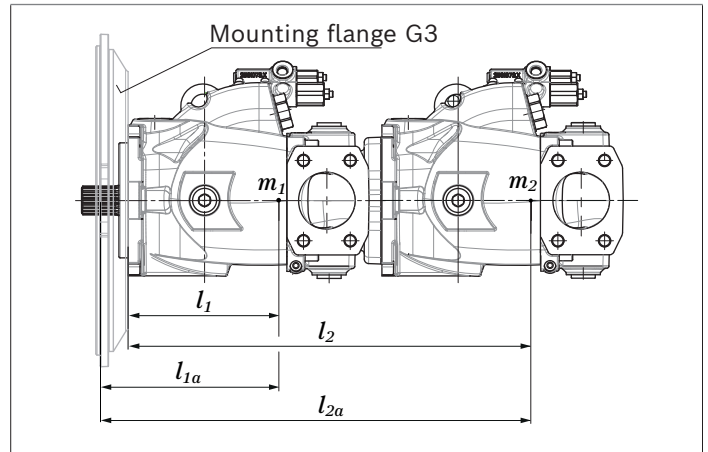

$m_1, m_2, m_3 \dots$	Weight of pump	[kg]
$l_1 (l_{1a}), l_2 (l_{2a}), l_3 (l_{3a}) \dots$	Distance from center of gravity	[mm]

Mass torque

$$M_m = (m_1 \times l_1 (l_{1a}) + m_2 \times l_2 (l_{2a}) + m_3 \times l_3 (l_{3a})) \times \frac{1}{102} \text{ [Nm]}$$

Weight approx.		NG	
		145	
Mounting flange	Through drive		
C2/D4	Without	m kg	57
	With	m kg	62
G3	Without	m kg	72
	With	m kg	77
Distance from center of gravity		145	
Mounting flange	Through drive		
C2/D4	Without	l_1 mm	145.7
	With	l_1 mm	155.6
G3	Without	l_{1a} mm	146
	With	l_{1a} mm	163

Connector for solenoids

DEUTSCH DT04-2P-EP04

Molded, 2-pin, without bidirectional suppressor diode.
The following type of protection ensues with the mounted mating connector:

- ▶ IPX7 (DIN/EN 60529) and
- ▶ IPX9K (DIN 40050-9)

▼ Switching symbol

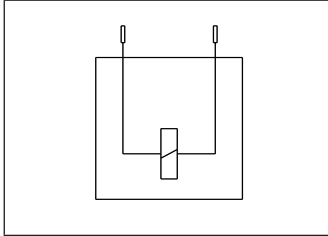

▼ Mating connector DEUTSCH DT06-2S-EP04

Consisting of	DT designation
1 housing	DT06-2S-EP04
1 wedge	W2S
2 sockets	0462-201-16141

The mating connector is not included in the scope of delivery.

This can be supplied by Bosch Rexroth on request (material number R902601804).

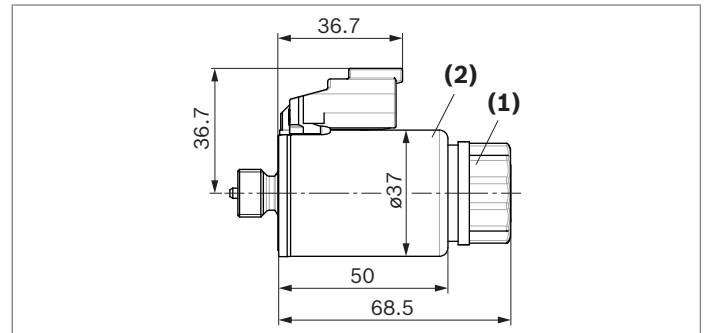

Notice

- ▶ If necessary, you can change the position of the connector by turning the solenoid body.
- ▶ The procedure is defined in the instruction manual 92704-01-B.
- ▶ Only the dead weight (<1 N) of the connection cable with a length of 150 mm may act on the plug-in connection and the solenoid coil with coil nut. Other forces and vibrations are not permissible. For example, this can be realized by suspension of the cable at the same vibration system.

Installation instructions

General

The axial piston unit must be filled with hydraulic fluid and air bled during commissioning and operation. This must also be observed following a longer standstill as the axial piston unit may empty via the hydraulic lines. The leakage in the pump housing must be discharged to the reservoir via the highest available drain port (**L**, **L₁**, **L₂**).

For combinations of multiple units, the leakage fluid must be drained off at each pump. If a shared drain line is used for several units, make sure that the respective case pressure in each unit is not exceeded. The shared drain line must be dimensioned to ensure that the maximum permissible case pressure of all connected units is not exceeded in any operating condition, particularly at cold start. If this is not possible, separate drain line must be laid, if necessary.

To prevent the transmission of structure-borne noise, use elastic elements to decouple all connecting lines from all vibration-capable components (e.g. reservoir, frame parts). Under all operating conditions, the suction lines and the drain lines must flow into the reservoir below the minimum fluid level. The permissible suction height h_s results from the total pressure loss. However, it must not be higher than $h_{S \max} = 800$ mm. The minimum suction pressure at port **S** must not fall below 0.8 bar absolute during operation and during cold start.

When designing the reservoir, ensure that there is adequate distance between the suction line and the drain line. We recommend using a baffle (baffle plate) between suction line and drain line. A baffle improves the air separation ability as it gives the hydraulic fluid more time for desorption. Apart from that, this prevents the heated return flow from being drawn directly back into the suction line. The suction port must be supplied with air-free, calmed and cooled hydraulic fluid.

Notice

In certain installation positions, an influence on the adjustment or control can be expected. Gravity, dead weight and case pressure can cause minor characteristic shifts and changes in actuating time.

For key, see page 25.

Installation position

See the following examples **1** to **6**.

Further installation positions are available upon request.

Recommended installation position: **1** and **2**

Key	
F	Filling / Air bleeding
S	Suction port
L; L₁; L₂	Drain port
SB	Baffle (baffle plate)
$h_{t \min}$	Minimum required immersion depth (200 mm)
h_{\min}	Minimum required distance to reservoir bottom (100 mm)
$h_{ES \min}$	Minimum height required to prevent axial piston unit from draining (25 mm)
$h_{S \max}$	Maximum permissible suction height (800 mm)

Notice

- ▶ Port **F** is part of the external piping and must be provided on the customer side to make filling and air bleeding easier.
- ▶ The drain ports **L₁** and **L₂** are present by default. Depending on the installation position, another drain port is required. Please specify in plain text.

Below-reservoir installation (standard)

Below-reservoir installation means that the axial piston unit is installed outside of the reservoir below the minimum fluid level.

▼ **Installation position 1**

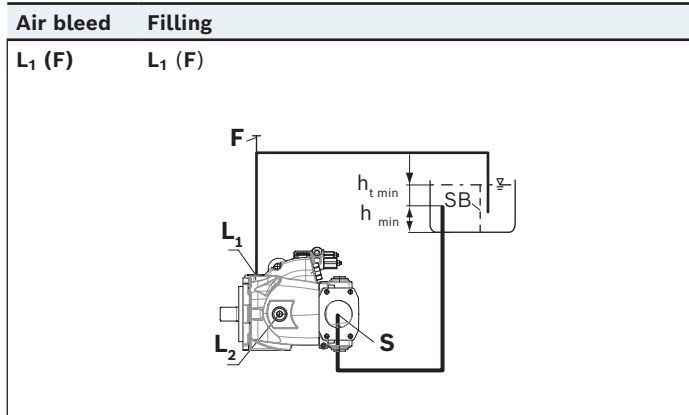

▼ **Installation position 2**

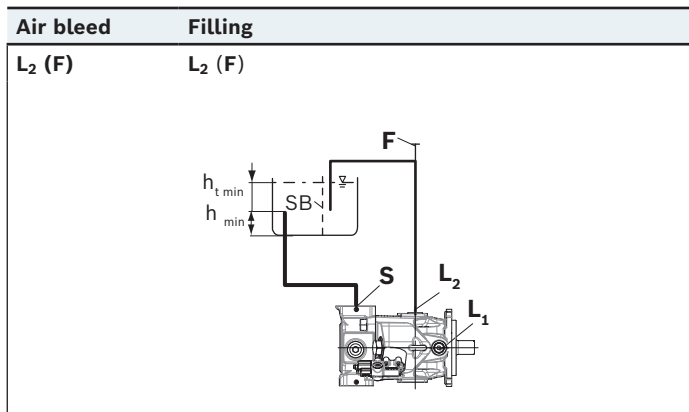

For key, see page 25.

Above-reservoir installation

Above-reservoir installation means that the axial piston unit is installed above the minimum fluid level of the reservoir.

Observe the maximum permissible suction height

$h_{s \max} = 800 \text{ mm}$.

▼ **Installation position 3**

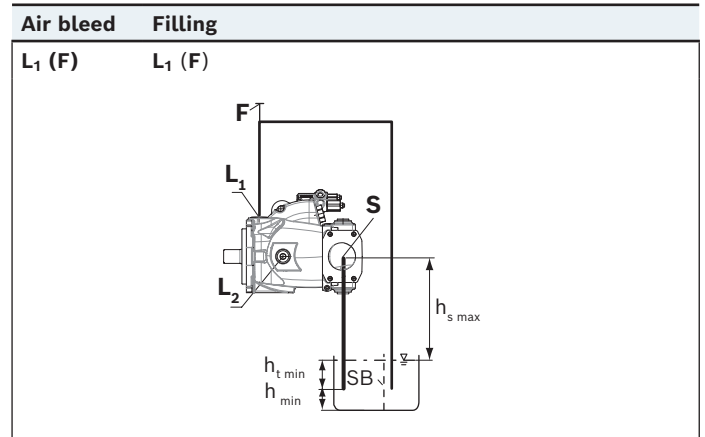

▼ **Installation position 4**

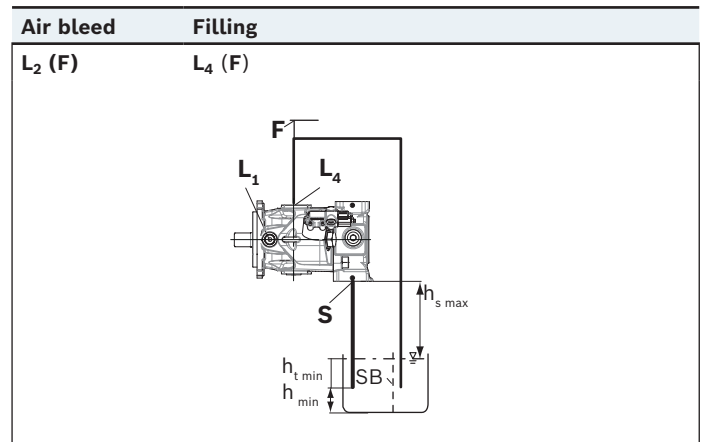

Inside-reservoir installation

Inside-reservoir installation is when the axial piston unit is installed in the reservoir below the minimum fluid level. The axial piston unit is completely below the hydraulic fluid.

If the minimum fluid level is equal to or below the upper edge of the pump, see chapter "Above-reservoir installation".

Axial piston units with electrical components (e.g. electric control, sensors) may not be installed in a reservoir below the fluid level.

Notice

- ▶ Our advice is to fit a suction pipe to the suction port **S** and to fit a pipe to case drain port **L**, **L₁** or **L₂**. In this case, the other drain port must be plugged. The housing of the axial piston unit is to be filled via **L**, **L₁** or **L₂** (see installation position 5 to 6) before the pipework is fitted and the reservoir is filled with hydraulic fluid.

▼ **Installation position 5**

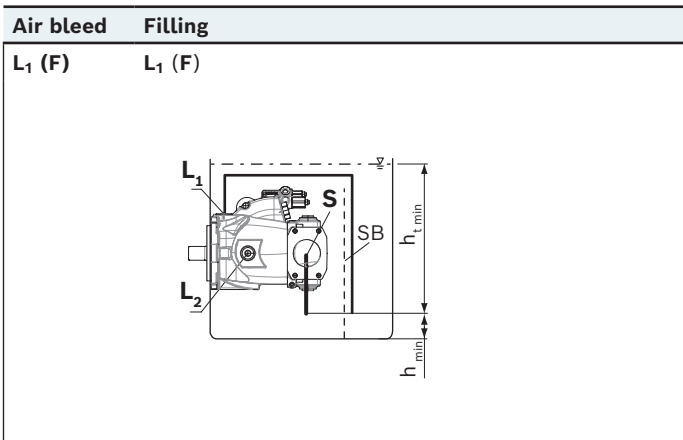

▼ **Installation position 6**

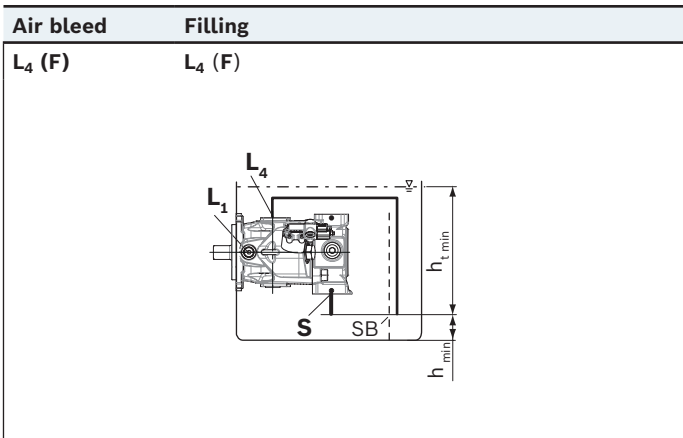

For key, see page 25.

Project planning notes

- ▶ The axial piston variable pump A10VOH145 is designed to be used in open circuit.
- ▶ The project planning, installation and commissioning of the axial piston unit requires the involvement of skilled personnel.
- ▶ Before using the axial piston unit, please read the corresponding instruction manual completely and thoroughly. If necessary, this can be requested from Bosch Rexroth.
- ▶ Before finalizing your design, please request a binding installation drawing.
- ▶ The specified data and notes contained herein must be observed.
- ▶ Depending on the operating conditions of the axial piston unit (working pressure, fluid temperature), the characteristic curve may shift.
- ▶ The characteristic curve may also shift due to the dither frequency or control electronics.
- ▶ Preservation: Our axial piston units are supplied as standard with preservation protection for a maximum of 12 months. If longer preservation protection is required (maximum 24 months), please specify this in plain text when placing your order. The preservation periods apply under optimal storage conditions, details of which can be found in the data sheet 90312 or the instruction manual.
- ▶ Not all configuration variants of the product are approved for use in a safety function according to ISO 13849. Please consult the proper contact at Bosch Rexroth if you require reliability parameters (e.g., $MTTF_d$) for functional safety.
- ▶ Depending on the type of control used, electromagnetic effects can be produced when using solenoids. Applying a direct voltage signal (DC) to solenoids does not create electromagnetic interference (EMI) nor is the solenoid affected by EMI. Electromagnetic interference (EMI) potential exists when operating and controlling a solenoid with a modulated direct voltage signal (e.g. PWM signal). Appropriate testing and measures should be taken by the machine manufacturer to ensure other components or operators (e.g. with pacemaker) are not affected by this potential.
- ▶ Pressure controllers are not safeguards against pressure overload. Be sure to add a pressure relief valve to the hydraulic system.
- ▶ For controllers requiring external pilot pressure, sufficient control fluid must be provided to the associated ports to ensure the required pilot pressures for the respective controller function. These controllers are subject to leakage due to their design. An increase in control fluid demand has to be anticipated over the total operating time. The design of the control fluid supply must thus be sufficiently large. If the control fluid is too low, the respective controller function may be impaired and undesired system behavior may result.
- ▶ For drives that are operated for a long period of time with constant rotational speed, the natural frequency of the hydraulic system can be stimulated by the excitation frequency of the pump (rotational speed frequency x 9). This can be prevented with suitably designed hydraulic lines.
- ▶ Please note the details regarding the tightening torques of port threads and other threaded joints in the instruction manual.
- ▶ The ports and fastening threads are designed for the p_{max} permissible pressures of the respective ports, see the connection tables. The machine or system manufacturer must ensure that the connecting elements and lines correspond to the specified application conditions (pressure, flow, hydraulic fluid, temperature) with the necessary safety factors.
- ▶ The service ports and function ports are only intended to accommodate hydraulic lines.

Safety instructions

- ▶ During and shortly after operation, there is a risk of burning on the axial piston unit and especially on the solenoids. Take the appropriate safety measures (e.g. by wearing protective clothing).
- ▶ Moving parts in control equipment (e.g. valve spools) can, under certain circumstances, get stuck in position as a result of contamination (e.g. contaminated hydraulic fluid, abrasion, or residual dirt from components). As a result, the hydraulic fluid flow and the build-up of torque in the axial piston unit can no longer respond correctly to the operator's specifications. Even the use of various filter elements (external or internal flow filtration) will not rule out a fault but merely reduce the risk. The machine/system manufacturer must test whether remedial measures are needed on the machine for the application concerned in order to bring the driven consumer into a safe position (e.g., safe stop) and ensure any measures are properly implemented.

Bosch Rexroth AG

An den Kelterwiesen 14
72160 Horb a.N.
Germany
Phone +49 7451 92-0
sales.mobile.horb@boschrexroth.de
www.boschrexroth.com

© Bosch Rexroth AG 2020. All rights reserved, also regarding any disposal, exploitation, reproduction, editing, distribution, as well as in the event of applications for industrial property rights. The data specified within only serves to describe the product. No statements concerning a certain condition or suitability for a certain application can be derived from our information. The information given does not release the user from the obligation of own judgment and verification. It must be remembered that our products are subject to a natural process of wear and aging.